



Exmoor & Dartmoor Electric



Instructions for Use, Installation & Servicing For use in GB & IE (Great Britain & Republic of Ireland).



IMPORTANT

THE OUTER CASING, FRONT AND GLASS PANEL BECOME EXTREMELY HOT DURING OPERATION AND WILL RESULT IN SERIOUS INJURY AND BURNS IF TOUCHED. IT IS THEREFORE RECOMMENDED THAT A FIREGUARD COMPLYING WITH BS 8423:2002 IS USED IN THE PRESENCE OF YOUNG CHILDREN, THE ELDERLY OR INFIRM.

For use with 230v 50Hz electricity supply only.

Please read these instructions carefully before installation and keep them in a safe place.

They will be needed when maintenance or servicing is required.

THIS APPLIANCE MUST BE EARTHED

Contents

Covering the following models:

Model	Code
Exmoor - Small	YM-E9001FL
Dartmoor - Single Door	YM-E5201FL
Dartmoor - Double Door	YM-E5202FL

- User Instructions.....3**
 - 1. Important Information & Health and Safety..... 3
 - 2. Operating Instructions 3
 - 3. Maintenance 5
 - 4. Removing & Replacing Doors..... 5
- Installation Instructions.....6**
 - Technical Specifications 6
 - Appliance Dimensions..... 6
- Installation.....7**
 - 1. Fitting Appliances 7
- Servicing8**
 - 1. Fault Finding..... 8
 - 2. How to Wire a Plug 8
 - 3. Servicing Requirements 9
 - 4. Replacing the front LED Board 9
 - 5. Replacing the PCB..... 9
 - 6. Replacing the Motor & Effects Unit..... 9
 - 7. Replacing the Middle LED Board..... 10
 - 8. Replacing the Rear LED Board..... 10
 - 9. Replacing the Heater Assembly 10
- Spare Parts List.....12**
- Wiring Diagram.....13**



To receive your Extended Warranty your Yeoman appliance must have been purchased from our Expert Retailer Network and registered within one month of purchase or installation. Please note that all warranties are effective from the date of purchase. Any Yeoman product purchased outside of our Extended Retailer Network, or not registered within the stated time will carry a standard 12 month warranty.

Full terms and conditions are detailed in the Warranty Statement on the Yeoman website www.yeomanstoves.co.uk. In the event of any conflict of information the wording on the website shall prevail.

Important Note: Should any problems be experienced with your product, claims must first be submitted to the Expert Retailer where the appliance was purchased from who will offer immediate assistance or contact Yeoman on your behalf.

Registration No WEE/DH1656ZW
 In accordance with European Directive 2002/96/EC, waste electrical and electronic equipment (WEEE) must not be disposed of with household waste.



At the end of its useful life please take this product to an appropriate recycling centre or collection point. You can find your nearest recycling centre by using the bank locator at www.recycle-more.co.uk for UK customers, www.weeeireland.ie for customers in the Republic of Ireland, or by contacting your local authority.

User Instructions

How to use these instructions

The contents of Sections 1, 2 and 3 apply to all the models in our Electric Range.

The content of Section 4, Remove and Replace Door, gives different instructions for each model type.

Select the relevant information for your model.

1. Important Information and Health and Safety



ALL APPLIANCES DESCRIBED IN THESE INSTRUCTIONS ARE HEAVY. SEEK ASSISTANCE BEFORE UNLOADING AND LIFTING.

- 1.1 **Read all of the instructions carefully before using the appliance.**
- 1.2 **Remove all packaging and dispose of at an appropriate recycling facility.**
- 1.3 To remove the protective packaging and fitting kit from inside a new appliance, choose the instruction corresponding to your model from Section 4.
- 1.4 Do not locate this appliance immediately below a fixed socket outlet.
- 1.5 Parts of this appliance is considered by the manufacturer to be a working surface which becomes hot when the fire is switched on. You must use a suitable fire guard to protect children, the elderly and the infirm.
- 1.6 Do not use this appliance in the immediate surroundings of a bath, shower, swimming pool or any other area where the appliance could come into contact with water or humidity, e.g. a bathroom.
- 1.7  **WARNING! DO NOT COVER**
Do not allow the appliance to be covered or let the air inlet/outlet become obstructed as the appliance may overheat. Please note the warning symbol on the appliance (see above).
- 1.8 **For indoor use only.** This appliance is not suitable for use outside the house.
- 1.9 Keep the power cord away from hot surfaces and hot conditions. Do not route the power lead in front of the appliance.
- 1.10 This appliance must stand on a clean, level, firm surface. Do not stand the fire on a carpet. Ensure that furniture, curtains etc. are positioned no closer than 1m and the fire stands on a surface that can withstand temperatures of 90°C for prolonged periods. Do not allow rugs to be placed within 500mm of the front of the appliance.
- 1.11 When the fire has been installed, the position of the plug must be accessible.

- 1.12 Where the electricity supply cable has to pass through a fire place, stone surround etc. ensure suitable rubber bushes are fitted at possible wear points.
- 1.13 If installed in an open fireplace, blank off the chimney to reduce the risk of a back draught which can cause the safety cut-out to operate.
- 1.14 If the electricity supply cable is damaged do not use the appliance until it has been replaced. For safety reasons the replacement has to be carried out by Yeoman, a Yeoman service agent or a similarly competent electrician.
- 1.15 Do not use this appliance with any kind of timer, programmer or thermal control or other device that will switch the appliance on or off automatically.
- 1.16 Do not operate the appliance if it is damaged.
- 1.17 Repairs of electrical appliances must only be performed by an electrical engineer. Should the appliance fail to operate, or in case of any damage, please contact the retailer from whom the appliance was purchased.
- 1.18 **Never leave the heater unattended while it is in use.** Always switch the product to the OFF position and unplug it from the electrical outlet when not in use.
- 1.19 **This appliance is not intended to be used by persons under the age of 12, persons with reduced physical, sensory or mental capabilities or persons with lack of experience and knowledge in the safe operation of the appliance.**
The appliance may be operated by persons above the age of 12 provided they have been instructed in the safe use of the appliance and that they understand the hazards involved. Persons above the age of 12 may also operate the appliance under the supervision of a responsible adult.
- 1.20 Parts of this appliance become hot whilst in operation and under no circumstances should persons under the age of 12 be left alone with the product when it is in operation unless a suitable fireguard is used to protect them against the possibility of coming into direct contact with the appliance.

2. Operating Instructions



WARNING! Do not operate the appliance if it is damaged or has malfunctioned. If you suspect the appliance is damaged or has malfunctioned call a qualified service engineer to inspect the appliance, and replace any part of the electrical system if necessary, before reuse.

GENERAL

- 2.1 The appliance can be operated by the infrared handset or the manual controls on the bottom right hand side of the appliance.

PREPARATION BEFORE USE

Batteries:

- 2.2 Ensure that the handset battery is new and is inserted correctly.

User Instructions

2.3 Dispose of old batteries at an appropriate recycling facility.

When using the handset:

2.4 Ensure the handset is pointed at the infrared sensor located behind the flame effect screen at the back of the inside of the appliance.

LOCATION OF POWER SWITCH

2.5 The mains power switch is located on the control panel on the lower right-hand side of the appliance, see Diagram 1.

2.6 Switch ON (—) before operating either the remote or manual controls.

2.7 A beep is heard to indicate the fire is ready for use.

Remote & Manual Operation

2.8 The following functions can be controlled using the manual controls or remote handset:

- Heat settings 1 and 2
- Brightness of the fuel and flame effect
- Colour of the flames

2.9 The Standby function and the thermostat can only be operated via the manual controls.

2.10 The effects can be turned off using the remote, returning the appliance to Standby.

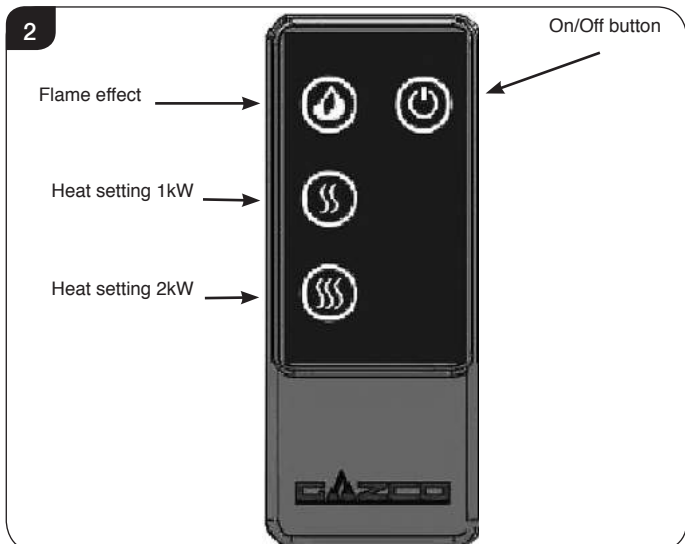
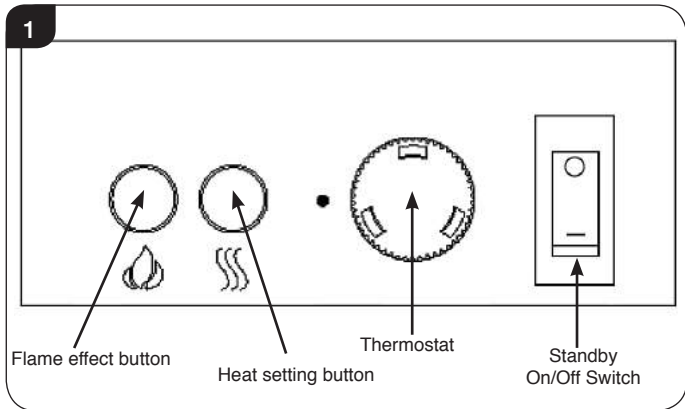

Standby On/Off

2.11 The appliance is in Standby mode when the power is switched on via the manual control panel. You must have this power supply ON (—) before using the manual or remote controls (see 2.5).

Turning On the Appliance

Flame Effects:

2.12 The flame effect button on both the manual and remote controls has 4 settings:

- Press **once** for maximum brightness of fuel and flame effects.
- Press **twice** for medium brightness.
- Press **three times** for minimum brightness.
- Press **four times** for maximum brightness of fuel and additional blue flame effects.

1	2	3	4
Maximum	Medium	Minimum	Maximum plus blue flame effects

Turning On the Heat:

2.13 **When turning on the heater you must always press the 1kW button. Do not start the fire using the 2kW setting.**

2.14 **It is NOT advisable to run the heater without the flame effects switched on.**

2.15 Press the 1kW button to turn the fan heater ON. One red indicator light will be displayed behind the flame effect screen at the back of the inside of the appliance. The appliance will blow cold air for approximately 8 seconds before the heater comes on. On this setting the heater will operate at half its maximum temperature.

2.16 Press the 2kW button **once** to turn the fan heater to its maximum temperature. Two red indicator lights will be displayed behind the flame effect screen at the back of the inside of the appliance. After approximately 8 seconds the heater will operate at its maximum temperature.

2.17 **Pressing the 2kW button again will turn the heater OFF** and cold air will be blown for approximately 8 seconds to cool the appliance.

2.18 Press the 1kW button to return to the lower heat setting.

2.19 Press the On/Off button to turn off **ALL** settings and return to Standby. Cold air will be blown for approximately 8 seconds to cool the appliance.

2.20 **The appliance should be turned off via the On/Off switch when it is not in use.**

User Instructions

Thermostatic Control

- 2.21 The appliance is fitted with a thermostat, see Diagram 1, which can control the room temperature between approximately 9°C and 34°C. The edge of the thermostat control dial is numbered 1 - 9 with 1 being the coolest setting and 9 being the warmest. If the room temperature is too high turn the thermostat dial in an anti-clockwise direction. If the room temperature is too low turn the dial in a clockwise direction.

Log Effect

- 2.22 **Log effect appliances have a glass fibre fuel bed which may give off a slight smell when first used. This is normal and should disappear after a day or two.**

Thermal Safety Cutout

The appliance is fitted with a thermal safety cutout, which operates if it overheats. If this happens:

- 2.23 Unplug the appliance and allow it to cool for 5 - 10 minutes.
- 2.24 Check the air inlets/outlets for any obstruction and clear, see Maintenance, Section 3.4.
- 2.25 Plug in appliance and switch it on. The cutout will re-set and the appliance should function correctly. If this is not the case:
- 2.26 Unplug once more and have the fire checked by a competent electrician.

3. Maintenance

- 3.1 **ALWAYS UNPLUG FROM MAINS SUPPLY BEFORE CLEANING OR UNDERTAKING ANY MAINTENANCE**

CLEANING

- 3.2 Only clean the outer casing when it is cold. Do not use abrasive cleaners.
- 3.3 For painted castings, wipe with a damp cloth and buff with a lint free duster.

CLEANING AIR INLETS

- 3.4 Ensure the appliance is unplugged.
- 3.5 Clean the air inlet and outlet grilles regularly with a soft cloth or the nozzle of a vacuum cleaner.
- Dust build-up can inhibit efficient performance of the fan and lead to the safety cut-out operating.**
- 3.6 Keep the area around the appliance clean and free of fluff, dust or pet hair.
- 3.7 In particular, build-up of dust etc. can occur around the heater area under the appliance. Take particular care to keep this area free from such particles on a regular basis to prevent build-up.

CLEANING LOG MOULDING

- 3.8 Ensure the appliance is unplugged and cold before handling log moulding.
- 3.9 Follow Section 4, choosing relevant model, to access and remove log moulding.
- 3.10 Dust off any build-up with a brush or damp cloth and replace.

4. Removing & Replacing Doors and Removal of Fuel Bed



WARNING: DOOR CASTINGS ARE EXTREMELY HEAVY - SEEK ASSISTANCE BEFORE REMOVAL.

Please note: The fuel bed is secured by 2 x screws on the lower panel on the front of the appliance.

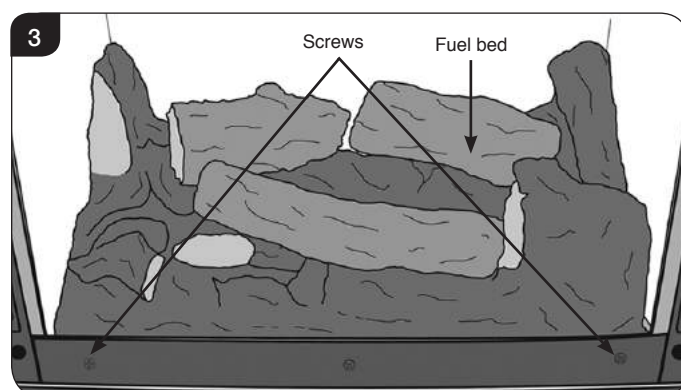

- 4.1 **Single Door Models:** Turn the right rose on the door facia. **Double Door Models:** Turn the right handle at the top of the door.
- 4.2 Open the door(s).
- 4.3 Remove the top glass clamp and **hold the glass steady.**
- 4.4 Remove the bottom glass clamp.
- 4.5 Remove the glass.
- 4.6 Remove the fuel bed, lifting the back away from the appliance.
- 4.7 Replace the lamp bulbs.
- 4.8 **Replace the fuel bed taking care not to damage the plastic screen.**
- 4.9 Reassemble in reverse order.

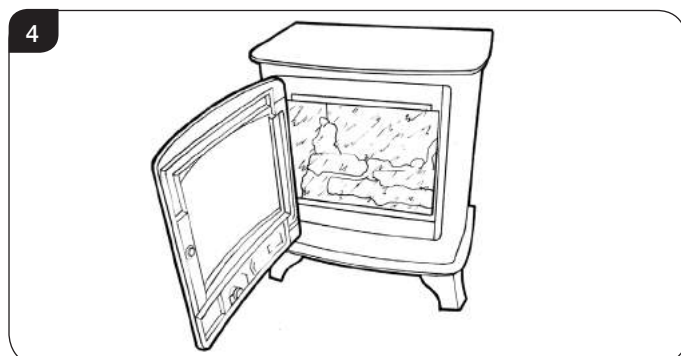

Installation Instructions

Technical Specification

These instructions cover the following models:

Model	Code
Exmoor - Small	YM-E9001FL
Dartmoor - Single Door	YM-E5201FL
Dartmoor - Double Door	YM-E5202FL

These appliances have 3 modes of operation:

- Flame effect only - with brightness and flame colour adjustment
- Flame effect + 1kW heating
- Flame effect + 2kW heating

A 230v 13amp 50Hz supply is required

Maximum power consumption is 2000 watts

THIS APPLIANCE MUST BE EARTHED

A 1.8 metre lead with plug containing a 13 amp fuse is supplied. Only use a 13 amp fuse with this appliance.

Remote control handset battery (CR2032)

This appliance has been certified for use in countries other than those stated. To install this appliance in these countries, it is essential to obtain the translated instructions and in some cases the appliance will require modification. Contact Gazco for further information.

PACKING CHECKLIST

Appliance Description	Fixing Kit containing:
All Models	1 x Instruction Manual 1 x Handset 1 x Battery

ALL INGLENOOK FIREPLACE OPENINGS:

For all models the dimensions required for an inglenook installation can be calculated by adding 225mm (9") to the height of the appliance and 150mm (6") to each side. An additional 50mm (2") must be added to the depth to provide adequate space behind the appliance.

Appliance Dimensions

EXMOOR

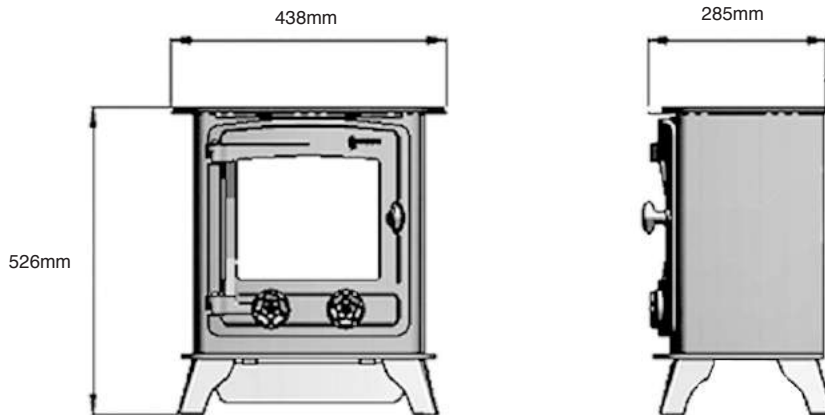

DARTMOOR

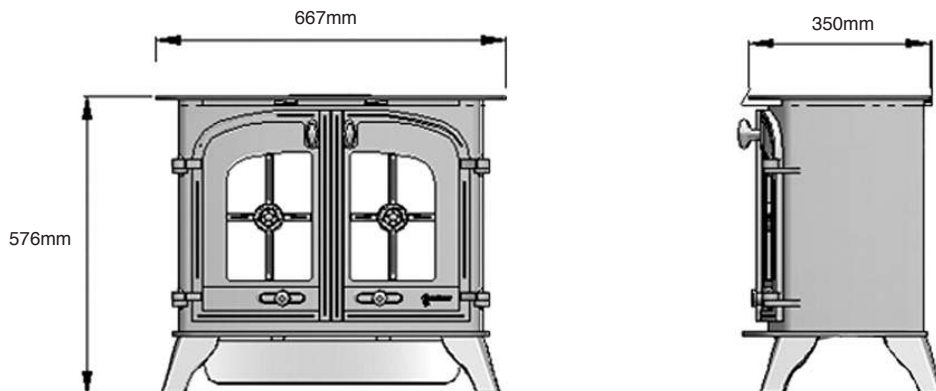

Installation Instructions

1. General

1.1 TOOLS REQUIRED

No tools are required to install this appliance.

1.2 UNPACKING THE FIREPLACE

WARNING! DO NOT use this appliance if any part has been exposed to water.

Immediately call a qualified service technician to inspect and to replace any part of the electrical system if necessary.

- 1.3 Open the packaging carefully and remove the polystyrene. Remove and discard the plastic bag. Keep plastic wrapping away from children. Be responsible when handling the packing materials.

- 1.4 Check all parts and accessories are removed before disposing of any packaging. If necessary keep the original packaging for future transport and/or storage.



This appliance is heavy and does not require anchoring to the hearth or floor, but in certain circumstances the appliance can become unstable e.g. when leaning on the appliance. If this is likely, secure the appliance to the hearth or floor with suitably strong fixings.

2. Locating the Appliance

The appliance may be installed virtually anywhere in your home. However, when choosing a location ensure that the general instructions are followed.

- 2.1 For best results, install out of direct sunlight.
- 2.2 If the power cord is damaged contact your Yeoman retailer for a replacement. Only use genuine Yeoman parts on this appliance.
- 2.3 The appliance should be located close to a suitable mains socket to enable connection. The electrical socket must be easily accessible to allow disconnection when the appliance is fitted.
- 2.4 This appliance must stand on a clean, level, firm surface. Do not stand the appliance on a carpet. Ensure that furniture, curtains etc. are positioned no closer than 1m and the appliance stands on a surface that can withstand temperatures of 90°C for prolonged periods. Do not allow rugs to be placed within 500mm of the front of the appliance.

WARNING! KEEP ANY COMBUSTIBLE MATERIALS AT LEAST 1M FROM THE FRONT AND SIDES OF THE APPLIANCE

ALL INGLENOOK FIREPLACE OPENINGS:

For all models the dimensions required for an inglenook installation can be calculated by adding 225mm (9") to the height of the appliance and 150mm (6") to each side. An additional 50mm (2") must be added to the depth to provide adequate space behind the appliance.

3. Fitting the Appliance.



IMPORTANT: THE OUTER PANNELLING IS MADE FROM CAST IRON. USE CAUTION WHEN INSTALLING, REMOVING AND STORING AS THE COMPONENTS ARE HEAVY AND SHOULD BE HANDLED CAREFULLY.

Most stoves are heavy and do not require anchoring to the hearth or floor, but in certain circumstances the appliance can become unstable e.g. when leaning on the stove. If this is likely, secure the appliance to the hearth or floor with suitably strong fixings.

- 3.1 Position the stove ensuring all appropriate clearances are observed.
- 3.2 Mark the position of the holes in the fixing brackets attached to the inside of the rear legs.
- 3.3 Remove the stove and drill holes using an appropriate drill.
- 3.4 Push rawl plugs into the holes and insert the wood screws until the head is approximately 3mm proud of the hearth.
- 3.5 Place the stove in position over the brackets so that the screw heads locate in the large part of the slot.
- 3.6 Push the stove back so that the screw heads engage fully into the narrow part of the slot.
- 3.7 Tighten the screws if desired.
- 3.8 Connect to the mains via the power socket.

Servicing Instructions

1. Fault Finding

No illumination or uneven lighting:

- 1.1 Check the heater is working. If YES, one or more of the LED boards will need replacing. This must be undertaken by a suitably qualified person (see Servicing Requirements).
- 1.2 If NO, first change the 13amp fuse for one known to work. If the fire still does not work, check the socket by plugging in a working appliance. If this too fails to operate, call in a competent electrician to check the socket.

Illumination but no heat:

- 1.3 The safety cut-out has operated to protect against overheating (see User Instructions, Section 2). Ensure the air inlet and outlet grilles are free of dust or any other obstruction.
- 1.4 The thermostat control dial may be set too low. Turn the dial clockwise until the heater turns on.

Remote control fails to work:

- 1.4 Check that the batteries are new and correctly fitted. Replace if necessary.
- 1.5 Ensure that the handset is pointed towards the appliance.

2. How to wire a plug

To change the plug supplied with this fire, follow the instructions below. The instructions assume that the wire has been cut.



WARNING – FAILURE TO CONNECT THE WIRES CORRECTLY COULD PUT PEOPLE AT RISK FROM ELECTRIC SHOCK OR FIRE. IF IN DOUBT CONSULT A QUALIFIED ELECTRICIAN.

UK Plug

Suitable for use in Cyprus, Malta, Ireland & Great Britain.

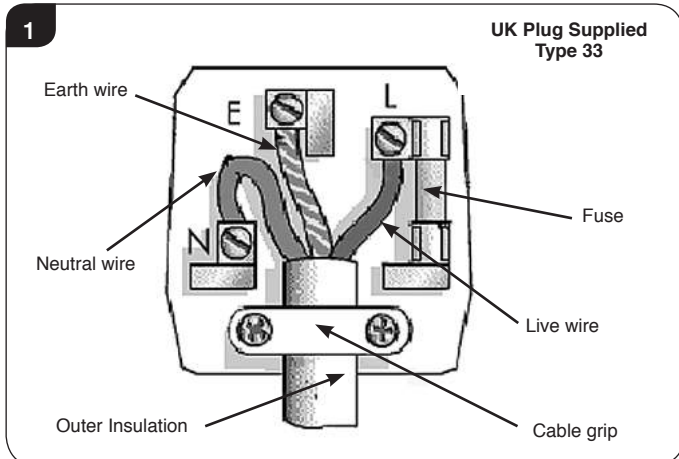

Live Wire	Brown	Terminal L / RED
Neutral Wire	Blue	Terminal N / BLACK
Earth Wire	Green & Yellow Stripes	Terminal E / / GREEN or GREEN & YELLOW

THIS APPLIANCE MUST BE EARTHED.

European Plug

Suitable for use in Austria, Belgium, Bulgaria, Czech Republic, Denmark, Estonia, Finland, France, Greece, Hungary, Germany, Italy, Latvia, Lithuania, Luxembourg, Netherlands, Poland, Portugal, Romania, Slovakia, Slovenia, Spain & Sweden.

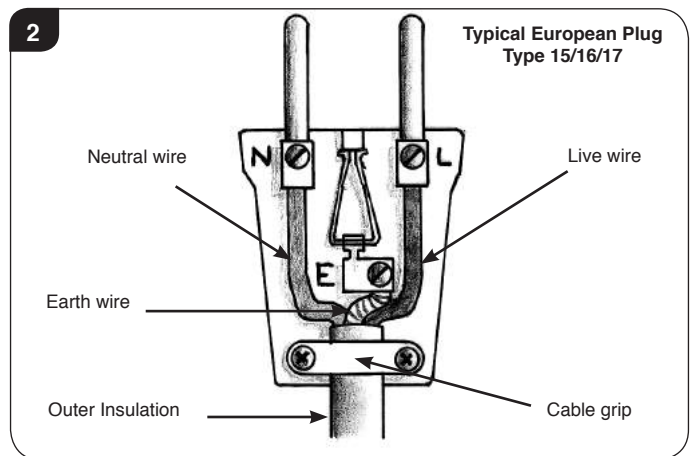

- 2.1 Dispose of the old plug safely. Ensure the new plug is not cracked or chipped.
- 2.2 Expose 4cm of the coloured wires and trim to the correct lengths so that they comfortably reach the correct terminals.
- 2.3 Ensure that the Earth wire has more slack than any of the other wires.
- 2.4 Remove some of the insulation to leave about 1cm of exposed metal core on each wire.
- 2.5 Twist the strands of the wire together.
- 2.6 Loosen the screw heads above each terminal.
- 2.7 Push the metal wire into the hole beneath each screw head or, dependent on plug design, wind the metal wire around the screw.
- 2.8 Ensure that the insulation reaches right up to each terminal as illustrated and there are no loose strands of wire.
- 2.9 Ensure the cable sits correctly under the cable grip and tighten to secure.
- 2.10 Refer to *Technical Specification* for fuse rating and fit the appropriate fuse into the plug.
- 2.11 Attach the plug cover.

Servicing Instructions

3. Servicing Requirements

THIS APPLIANCE MUST ONLY BE SERVICED BY A SUITABLY QUALIFIED PERSON.

BEFORE UNDERTAKING ANY WORK ON THE APPLIANCE:

- 3.1 Switch off the appliance and isolate it from the mains by unplugging the unit.
- 3.2 Wait for at least 10 minutes until the appliance has cooled down.
- 3.3 Following the appropriate instructions from User Instructions, Section 4, remove the door and glass front.
- 3.4 Remove the screws on the lower panel on the front of the appliance and carefully remove the fuel bed, see Diagram 3.

Please note: The fuel bed is secured by 2 x screws on the lower panel on the front of the appliance.

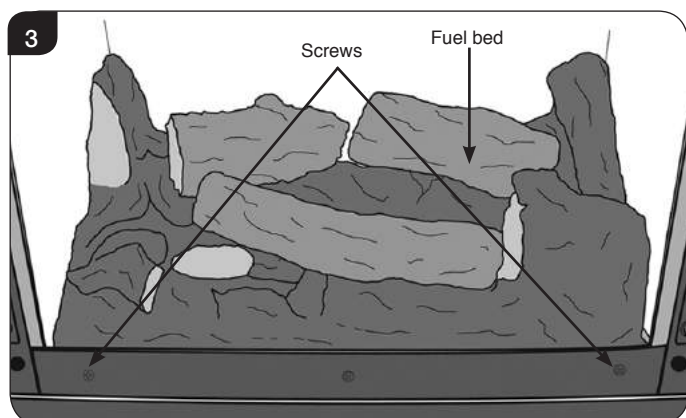

4. Replacing the front LED Board

- 4.1 If an LED fails to light you will notice an uneven or unlit fuel effect. To replace the front LED board (for middle and rear boards see Sections 7 & 8):
- 4.2 Disconnect all wires from the front LED board, noting their orientation.
- 4.3 The board is secured by 2 x plastic push fasteners, see Diagram 4. Using pliers, gently squeeze the head of the fasteners to release the board.

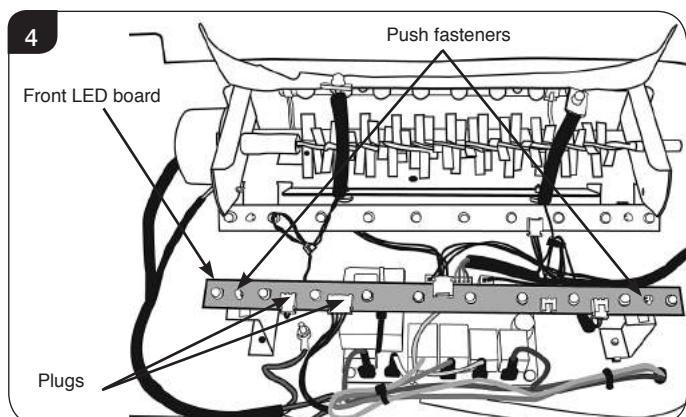

- 4.4 Dispose of the board at an appropriate recycling centre.
- 4.5 To connect the new LED board push the fasteners through the ready drilled holes and ensure that all wires are correctly connected.

5. Replacing the Printed Circuit Board

- 5.1 To remove the PCB first remove the front LED board following instructions Section 4.
- 5.2 The PCB is fixed to the base of the appliance using 2 x push fasteners and 2 x screws, see Diagram 5. Release board from fasteners and remove screws.

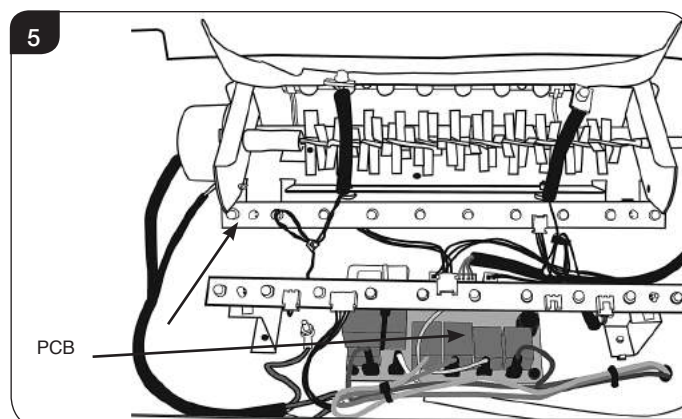

- 5.3 The wires should now be disconnected from the PCB one by one. As each wire is disconnected from the old PCB attach it to the new PCB to ensure correct orientation.
- 5.4 Fix the new PCB to the base of the appliance using the 2 x push fasteners and 2 x screws.

6. Replacing the Motor & Effects Unit

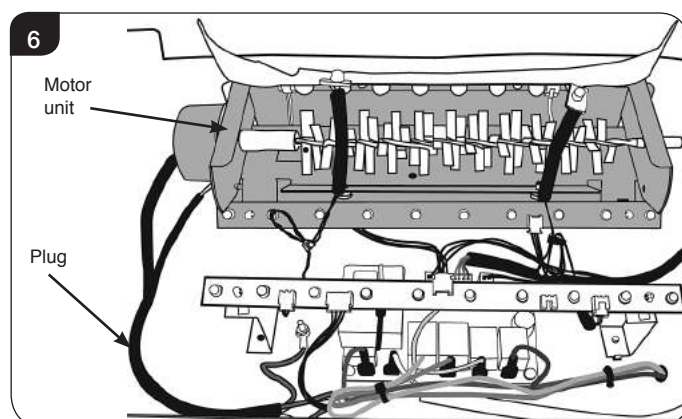

- 6.1 The motor & effects unit is attached by 4 x screws located at the rear of the appliance. It may be necessary to move the appliance from its location to gain access to the rear of the appliance. Remove the 4 screws on the lower rear casing.

Note: There are 2 x gaskets between the unit and the appliance. Remove and keep in a safe place.

Servicing Instructions

- 6.2 Disconnect the 2 x wires connecting the 2 x 'flying' LEDs to the front LED board, noting their orientation.
- 6.3 Lift and rotate the motor unit to give access to the rear LED board.
- 6.4 Disconnect both wires from the rear LED board, noting the orientation.
- 6.5 Unplug the cables connecting the motor unit and the PCB.
- 6.6 The motor and effects unit can now be removed and replaced as a whole unit.
- 6.7 Replace in reverse order. Ensure to replace gaskets when reattaching motor to appliance body and that all wires are correctly connected.

7. Replacing the Middle LED Board

- 7.1 The middle LED board is attached to the motor unit but can be replaced individually, see Diagram 7.

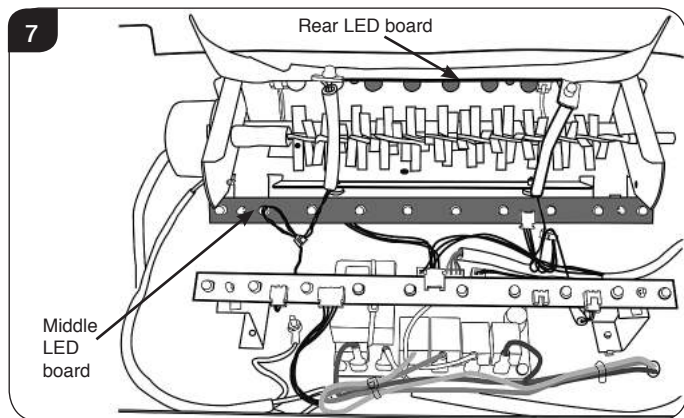

- 7.2 Disconnect the wire connecting the middle LED board to the rear LED board, noting its orientation.
- 7.3 Attach the new board and reconnect the wire.

8. Replacing the Rear LED Board

The rear LED board is attached to the motor unit but can be replaced individually, see Diagram 7.

- 8.1 Remove the motor unit following instructions in section 6 (it is not necessary to disconnect the motor unit from the PCB) and rotate to access the rear LED board.
- 8.2 Release the board by removing the 2 screws at either end of it.
- 8.3 Disconnect the wire connecting the rear LED board to the front LED board, noting its orientation.
- 8.4 Attach the new board using the 2 screws and reconnect the wire.
- 8.5 Replace motor and effects unit (see Section 6). Ensure to replace gaskets when reattaching motor to appliance body and that all wires are correctly connected.

9. Replacing the Heater Assembly

- 9.1 To access the heater assembly remove any loose top plates or panels before moving the appliance and carefully lay the appliance on its back.
- 9.2 Remove the 5 screws securing the heater casing to the bottom of the firebox, see Diagram 8.

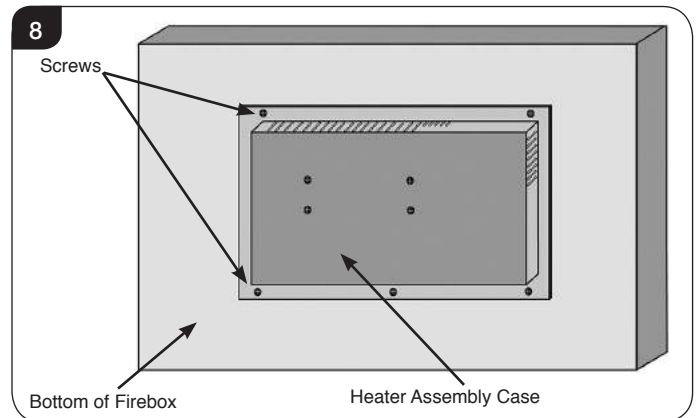

- 9.3 Remove the 4 screws from the front of the heater casing, see Diagram 9 to free the heater assembly.

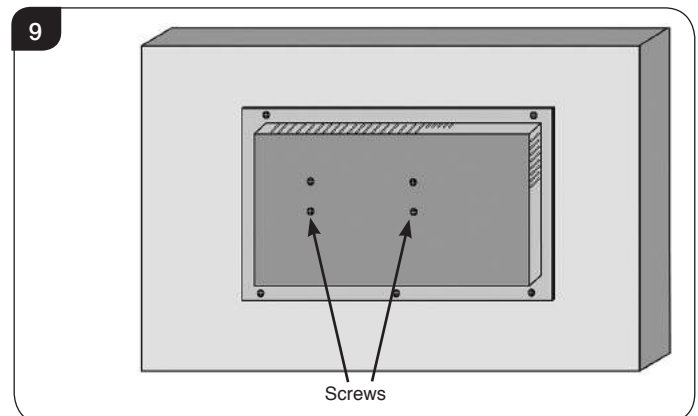

- 9.4 Tilt the heater casing forward and carefully remove the heater assembly, see Diagram 10.

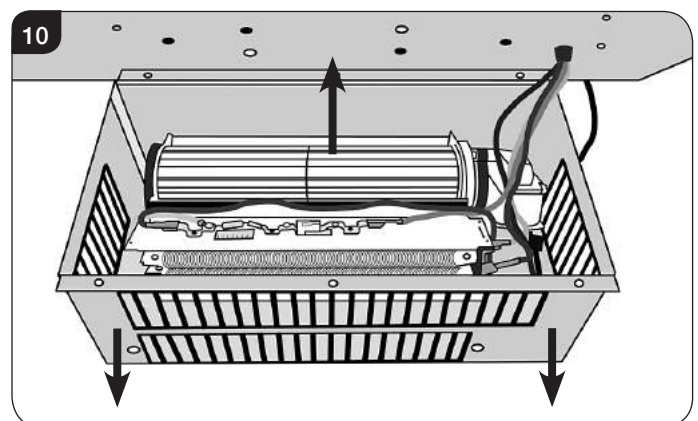

Servicing Instructions

- 9.5 Disconnect the 4 x coloured wires running from the firebox to the heater assembly, see Diagram 11 noting the orientation.

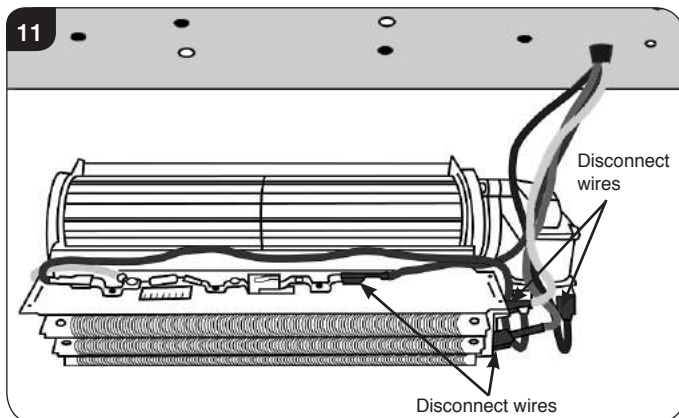

- 9.6 Fit new heater assembly, ensuring all wires are correctly attached and the heater is secured to its casing using 4 screws.
- 9.7 Reattach heater casing to bottom of firebox using 5 screws.
- 9.8 Relocate the appliance to its original position and replace any loose top plates or panels.

Spare Parts List

Parts Description	Part No.	
Model	EXMOOR	DARTMOOR
Log Fuel Effect	PL0116	PL0118
Handset	EL0491	
Battery	EL0492	
PCB Unit	EL0493	
Front LED Board	EL0494	
Middle LED Board	EL0496	
Rear LED Board	EL0498	
Motor & Effect Assembly	EL0495	
Heater Assembly	EL0497	

Wiring Diagram

All Models

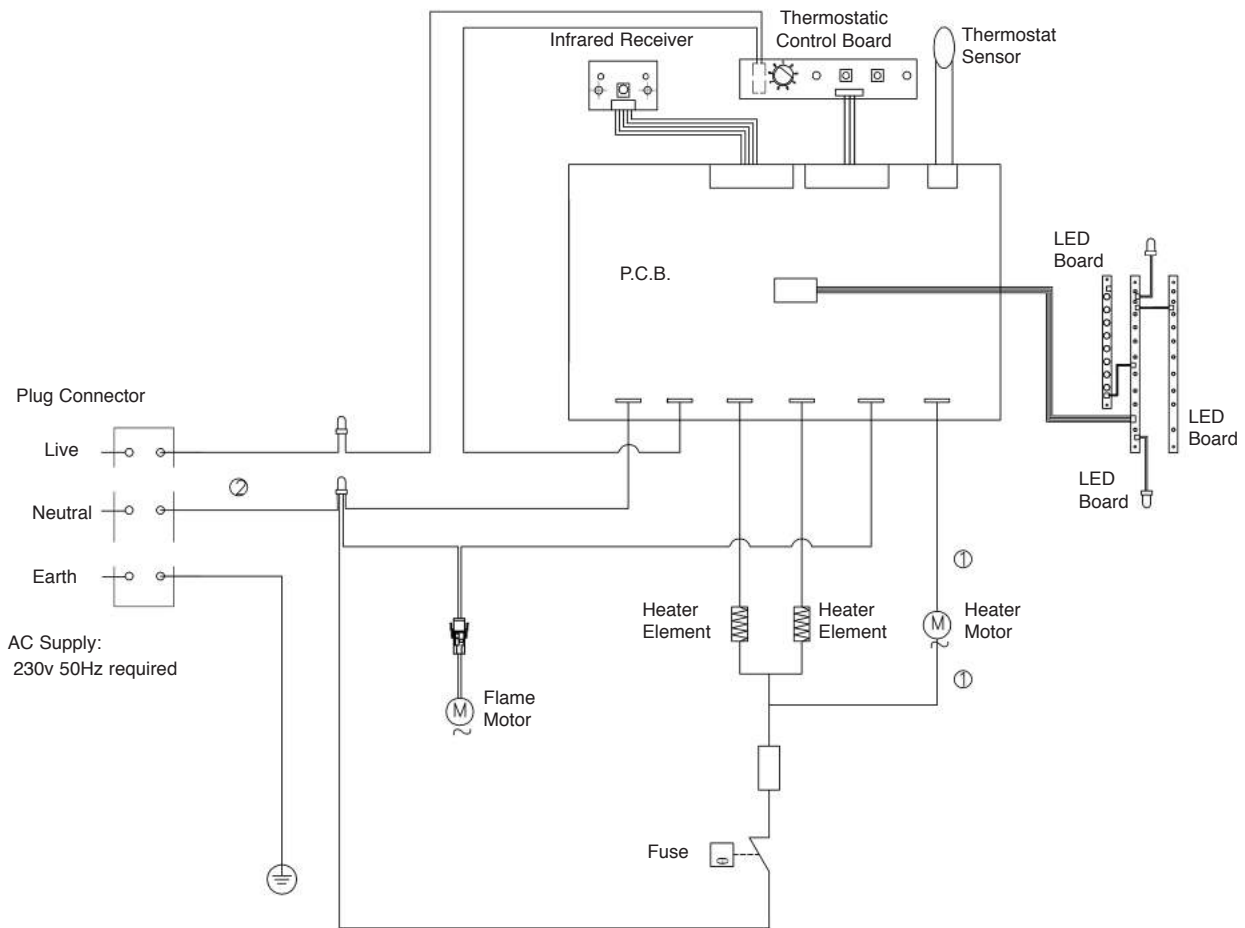



Yeoman Limited, Osprey Road, Sowton Industrial Estate, Exeter, Devon, England EX2 7JG

Technical Customer Services: (01392) 261950 Fax: (01392) 261951

E-mail: info@Yeoman.com

A member of the Stovax Group
E & O E