



Exmoor

Conventional Flue Log Effect Stove

With Upgradeable Control Valve



Instructions for Use, Installation and Servicing

For use in GB, IE (Great Britain and Republic of Ireland)

IMPORTANT

THE OUTER CASING, FRONT AND GLASS PANEL BECOME EXTREMELY HOT DURING OPERATION AND WILL RESULT IN SERIOUS INJURY AND BURNS IF TOUCHED. IT IS THEREFORE RECOMMENDED THAT A FIREGUARD COMPLYING WITH BS 8423:2002 IS USED IN THE PRESENCE OF YOUNG CHILDREN, THE ELDERLY OR INFIRM.

This product contains a heat resistant glass panel. This panel should be checked during Installation and at each servicing interval. If any damage is observed on the front face of the glass panel (scratches, scores, cracks or other surface defects), the glass panel must be replaced and the appliance must not be used until a replacement is installed. Under no circumstances should the appliance be used if any damage is observed, the glass panel is removed or broken.

It is essential that ALL of the screws that retain the glass frame are replaced and tightened correctly. Under no circumstances should the appliance be operated if any of these screws are loose or missing.

These Instructions must be left with the appliance for future reference and for consultation when servicing the appliance. Please make the customer aware of the correct operation of the appliance before leaving these instructions with them.

The commissioning sheet found on Page 3 of this Instruction manual must be completed by the Installer prior to leaving the premises.

Contents

Yeoman Exmoor - Conventional Flue

Covering the following models:

Model	NATURAL GAS	LPG
Flat Top	YM581-239	YM581-402
Low Canopy	YM581-298	YM581-447

Appliance Commissioning Checklist3

User Instructions4

Installation Instructions10

Technical Specifications 10

Site Requirements..... 12

Installation 14

Commissioning 19

Servicing Instructions.....20

Fault Finding..... 20

How to replace parts 22

Spare parts list 28

Service Records 30



If you have purchased your stove or fire from an authorised stockist within our Expert Retailer Network, then automatically your product will carry a 2 year warranty as standard. The 2 year warranty can be further extended to a total warranty period of 5 years by registering your Yeoman Stove or Fireplace within one month of the latter of the purchase date or installation date. Accordingly, the start date for the warranty period is the date of purchase. During the registration process, the Expert Retailer details will be required for your Extended Warranty to be activated. Any product purchased outside of our Expert Retailer Network will carry a standard 12 month, non-extendable warranty.

It is a condition of the Extended Warranty that the installation complies with the relevant Building Regulations and is carried out by a suitably trained and qualified individual (GasSafe in the UK or equivalent in other countries) with the certificate of installation and the Commissioning Report on Page 3 completed and retained by the end user.

Full terms and conditions are detailed in the Warranty Statement on the Yeoman website www.Yeomanstoves.co.uk. In the event of any conflict of information the wording on the website shall prevail.

Important Note: Should any problems be experienced with your product, claims must first be submitted to the Expert Retailer where the appliance was purchased from who will offer immediate assistance or contact Yeoman on your behalf.



It is a requirement of the Building Regulations 2010 that the installation of this appliance is notified to the Local Authority. It is the responsibility of the GasSafe registered installer to carry out this notification to the Local Authority via the GasSafe register Competent Persons Scheme in England and Wales (different rules apply in Scotland and Northern Ireland).

When the installation has been notified, GasSafe will send a Building Regulations Compliance Certificate to you containing details of the work completed. Please ensure that the person responsible for the installation of this appliance completes this notification and records it in the Appliance Commissioning Checklist on page 3.

IT IS YOUR RESPONSIBILITY TO COMPLY WITH THE BUILDING REGULATIONS AND BE ABLE TO PRODUCE THIS CERTIFICATE SHOULD IT BE REQUIRED IN THE FUTURE.

Appliance Commissioning Checklist

To assist us in any guarantee claim please complete the following information:-

IMPORTANT NOTICE

Explain the operation of the appliance to the end user, hand the completed instructions to them for safe keeping, as the information will be required when making any guaranteed claims.

FLUE CHECK	PASS	FAIL	
1. Flue Is correct for appliance			
2. Flue flow Test			
3. Spillage Test			
GAS CHECK			
1. Gas soundness & let by test			
2. Standing gas pressure	mb		
3. Appliance working pressure (on High Setting) NB All other gas appliances must be operating on full	mb		
4. Gas rate	m ³ /h		
5. Does Ventilation meet appliance requirements			
6. Have controls been upgraded (Upgradeable models only)	8455 Standard	YES	NO
	8456 Programmable Thermostatic and Timer	YES	NO
SAFETY CHECK			
1. Glass checked to ensure no damage, scratches, scores or cracks.			
2. Door secured correctly and all screws replaced			
BUILDING CONTROL NOTIFICATION	YES	NO	
1. Installer notified GasSafe/Local Authority of installation via Competent Persons Scheme?			

RETAILER AND INSTALLER INFORMATION

Retailer	Installation Company
.....
.....
Contact No.	Engineer
Date of Purchase	Contact No.
Model No.	Gas Safe Reg No.
Serial No.	Date of Installation
Gas Type	

User Instructions

Welcome

Congratulations on purchasing your Yeoman Exmoor stove, if installed correctly Yeoman hope it will give you many years of warmth and pleasure for which it was designed.

The purpose of this manual is to familiarise you with your appliance, and give guidelines for its installation, operation and maintenance. If, after reading, you need further information, please do not hesitate to contact your Yeoman retailer.

WARNING



In the event of a gas escape or if you can smell gas, please take the following steps:

- Immediately turn off the gas supply at the meter/emergency control valve
- Extinguish all sources of ignition
- Do not smoke
- Do not operate any electrical light or power switches (On or Off)
- Ventilate the building(s) by opening doors and windows
- Ensure access to the premises can be made

Please report the incident immediately to the National Gas Emergency Service Call Centre on 0800 111 999 (England, Scotland and Wales) , 0800 002 001 (N. Ireland) or in the case of LPG, the gas supplier whose details can be found on the bulk storage vessel or cylinder.

The gas supply must not be used until remedial action has been taken to correct the defect and the installation has been recommissioned by a competent person.

1. General

- 1.1 Installation and servicing must only be carried out by a competent person whose name appears on the Gas Safe register. To ensure the engineer is registered with Gas Safe they should possess an ID Card carrying the following logo:



- 1.2 In all correspondence, please quote the appliance type and serial number, which can be found on the databadge located on a tag/chain behind the appliance or on the Commissioning Checklist on Page 3.

- 1.3 **Do not** place curtains above the appliance: You must have 300mm (1') clearance between the appliance and any curtains at either side.
- 1.4 No furnishings or other objects should be placed within 1 metre of the front of the appliance.
- 1.5 If any cracks appear in the glass panel do not use the appliance until the panel has been replaced.
- 1.6 If, for any reason, the flue has to be removed from the appliance, the seals must be replaced in the inner spigot.
- 1.7 This product is guaranteed for 5 years from the date of installation, as set out in the terms and conditions of sale between Yeoman and your local Yeoman Retailer. Please consult with your local Yeoman Retailer if you have any questions. In all correspondence always quote the Model Number and Serial Number.

2. Operating the Appliance

- 2.1 The control valve is at the foot on the right-hand side of the appliance. It has two controls, see Diagram 1:
1. The right-hand knob controls the pilot ignition.
 2. The left-hand knob controls the main burner.

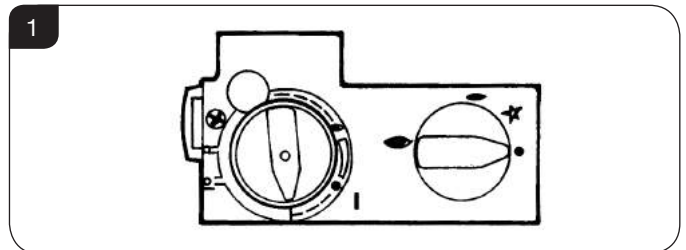

- 2.2 Refer to separate instructions if your appliance is upgraded to include battery remote control. The instructions below apply whether or not you have the remote upgrade.

Lighting the Pilot

- 2.3 To start the left-hand and right-hand control knobs must both point to off (●):
- 2.4 Press in the right-hand control knob and rotate anti-clockwise until a click is heard. Continue to press in. The knob points to the pilot (←).

The pilot is lit.

- 2.5 Keep the knob depressed for 10 seconds before releasing. The pilot remains lit.

Repeat the above steps if the pilot does not stay lit.

NOTE: If the pilot goes out, the Interlock system prevents you lighting again for a short period.

- 2.6 If, after repeating the above steps the pilot does not light, contact your Retailer or Installer.
- 2.7 Turn the right-hand knob to the left to main burner setting (↔).

User Instructions

Adjusting the Flame height

- 2.8 You can now adjust the flame height and temperature using the left-hand control knob.
- 2.9 Turn the left-hand knob anti-clockwise to increase the flame height.
- 2.10 Turn clockwise to decrease the height.

i **IMPORTANT: YELLOW FLAMES TYPICALLY APPEAR WHEN THE APPLIANCE HAS REACHED NORMAL OPERATING TEMPERATURE. THIS CAN TAKE UP TO 30 MINUTES.**

! **WARNING: IF THE APPLIANCE FAILS TO LIGHT OR BECOMES EXTINGUISHED IN USE, WAIT 3 MINUTES BEFORE ATTEMPTING TO RELIGHT.**

3. Turning OFF the Appliance

- 3.1 To turn the main burner off turn the left-hand knob until it points to off (●). Just the pilot remains lit.
- 3.2 Press in and turn the right-hand knob until it points to off (●). The pilot goes out.

4. Upgrading the Appliance

- 4.1 The appliance is fitted with a control valve that can easily be upgraded to battery powered remote control. There are two versions of this control which can be obtained through your local Yeoman retailer. There is no requirement for this upgrade to be carried out by an approved Gas Safe engineer. However Yeoman recommend that this task is undertaken by a suitably competent person.
- 4.2 This upgrade can be fitted before or after installation but if side clearances are limited then it will be easier to upgrade the appliance before installation. Full instructions are included with the kit.

Standard Remote Control (PART NUMBER 8455)

- 4.3 This remote control can control the gas appliance after the pilot has been lit. It can turn the main burner on and regulate it from low through to high and back again. It can turn the main burner off leaving the pilot burning.

Thermostatic and Timer Remote Control (PART NUMBER 8456)

- 4.4 This remote control can control the gas appliance after the pilot has been lit.

MANUAL MODE

Can be used to turn the main burner on and manually regulate it from low through to high and back again. It can also be used to turn the main burner off leaving the pilot burning.

AUTO MODE

Will automatically regulate the room to a pre-set temperature.

TIMER MODE

Will turn the appliance on and off according to a pre-set programme and automatically regulate the room temperature during the two on periods.

5. Cleaning the Appliance

! **WARNING: NEVER CLEAN THE APPLIANCE WHILE IT'S HOT. THE APPLIANCE STAYS HOT FOR A LONG TIME AFTER SHUTDOWN.**

IMPORTANT: THE OUTER PANNELLING OF THE APPLIANCE IS MADE FROM CAST IRON. USE CAUTION WHEN INSTALLING, REMOVING AND STORING AS THE COMPONENTS ARE HEAVY AND SHOULD BE HANDLED CAREFULLY.

Make sure the appliance and surrounds are cool before cleaning.

REMOVING THE DOOR

- 5.1 To open the door and access the interior; turn the right-hand rosette 90°, see Diagram 2 and pull the door open.

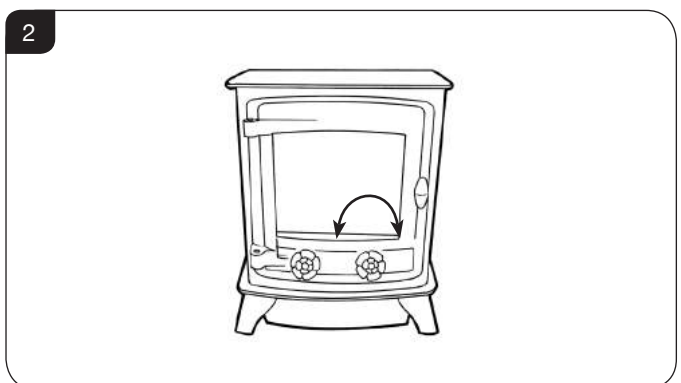

- 5.2 Remove the door casting assembly by removing the 2 hinge pins and lifting the door above the hinge blocks.

User Instructions

- 5.3 Remove the glass frame by undoing the 6 frame fixing screws and lifting clear, see Diagram 3. **Take care to support the glass window panel when removing the screws.**

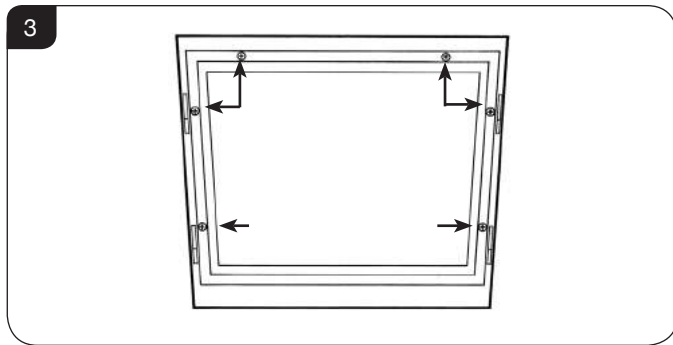

- 5.4 Place carefully to one side.
- 5.5 Lift out the log guard.
- 5.6 Carefully remove the ceramic fuel bed components and set aside. Protect the floor coverings and follow the advice given in Section 6.
- 5.7 The logs do not require cleaning. Do not use a vacuum cleaner or brush to clean the logs, any large pieces of debris can be removed by hand.
- 5.8 Ensure any debris is removed from the burner ports.
- 5.9 Replace the ceramics, see Section 6.
- The glass frame must be refitted to the appliance following cleaning or servicing.
- 5.10 Ensure that the rope seal on the back of the glass frame is intact and replace the 6 screws working from the top down. Tighten the screws evenly **DO NOT OVER TIGHTEN**, see Diagram 3.
- 5.11 Replace ALL of the securing screws ensuring that a screw is present in all fixing slots.



UNDER NO CIRCUMSTANCES SHOULD THE APPLIANCE BE USED IF ANY OF THE FRAME RETAINING SCREWS ARE LOOSE OR MISSING.

NEVER OPERATE THE APPLIANCE WHEN THE GLASS FRAME IS REMOVED, OR THE GLASS IS BROKEN.

- 5.12 Use a damp cloth to clean the outer casing of the appliance.

6. Arrangement of Fuel Bed

Advice on handling and disposal of fire ceramics



The fuel effect of the log version of this appliance is made from Refractory Ceramic Fibre (RCF), a material which is commonly used for this application.

Protective clothing is not required when handling these articles, but we recommend you follow normal hygiene rules of not smoking, eating or drinking in the work area and always wash your hands before eating or drinking.

To ensure that the release of RCF fibres are kept to a minimum, during installation and servicing a HEPA filtered vacuum is recommended to remove any dust accumulated in and around the appliance before and after working on it. When servicing the appliance it is recommended that the replaced items are not broken up, but are sealed within heavy duty polythene bags and labelled as RCF waste.

RCF waste is classed as stable, non-reactive hazardous waste and may be disposed of at a licensed landfill site.

Excessive exposure to these materials may cause temporary irritation to eyes, skin and respiratory tract; wash hands thoroughly after handling the material.

User Instructions

7. Log Layout

LOGS MUST BE POSITIONED ACCORDING TO THE FOLLOWING INSTRUCTIONS TO GIVE THE CORRECT FLAME EFFECT

All logs can be identified by a letter (A - E) on their underside. Logs B and E also have holes to locate each onto a burner stud.

- 7.1 Ensure the burner tray is clean and free from any debris, see Diagram 4.

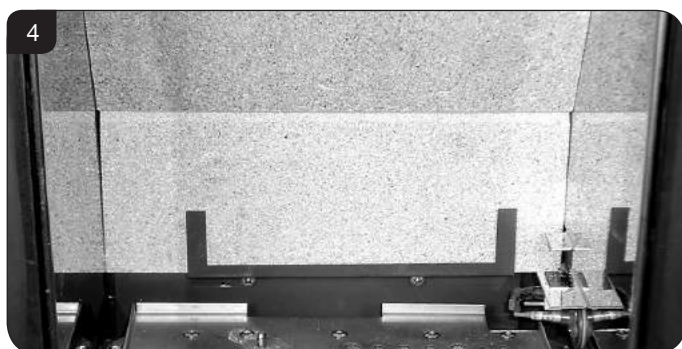

- 7.2 Place Log A on the higher rear bracket and push up against the back panel, see Diagram 5.

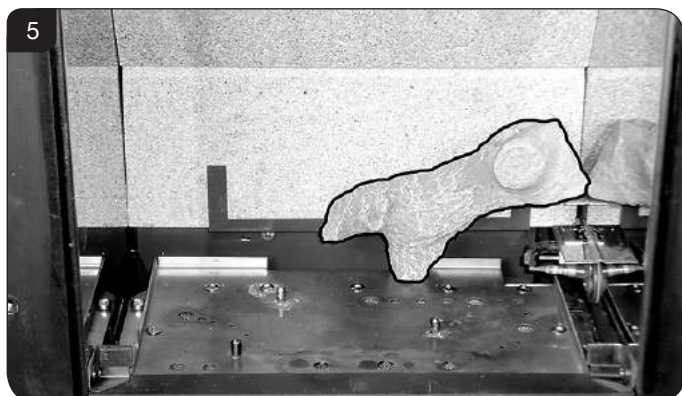

- 7.3 Place Log B over the two middle studs on the burner tray, see Diagram 6.

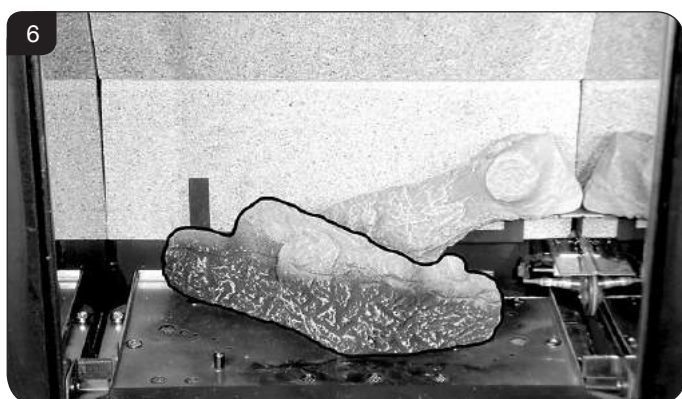

- 7.4 Place Log E onto the stud and behind the tag on the left hand side of the burner tray. Rest against Log B, see Diagram 7.

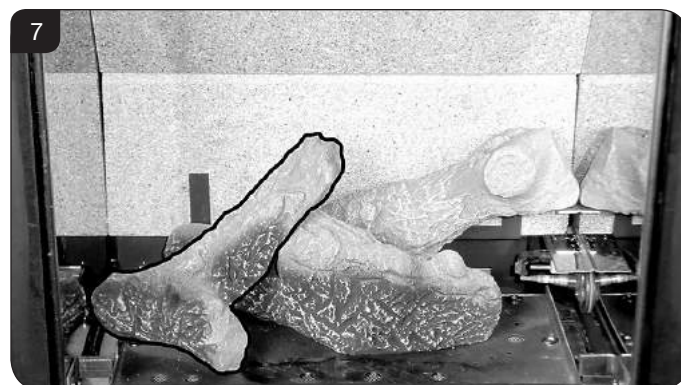

- 7.5 Place the small Ember at the front left of the firebox against the rear of the log support bracket to obscure the reflection of the burner screw.

Place the larger Ember on the lower bracket above the pilot on the right hand side with the thicker edge facing the front and flat edges to the base and side, see Diagram 8.

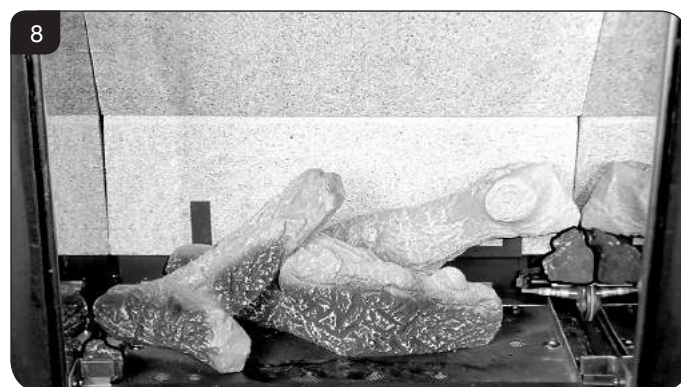

- 7.6 Log C rests on the cutout on Log E and is pushed up to the side and rear of the firebox, see Diagram 9.



User Instructions

- 7.7 Place the pointed bottom of log D into the corner of the burner tray and rest on the location stud in log B, see Diagram 10.



- 7.8 Use some of the Embaglow provided and cover the ports in the burner tray with a liberal amount of fibres. Use a small piece in front of the log on the left hand side and a long strip in front of log B, see Diagram 11.

NOTE: It is not necessary to use all of the Embaglow.

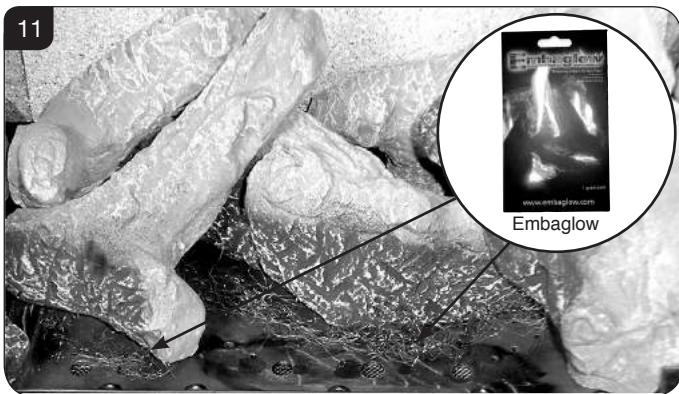

- 7.9 Lower log guard into position, see Diagram 12.



- 7.10 Ensure that the rope seal on the back of the glass frame is intact and replace the 6 screws working from the top down. Tighten the screws evenly **DO NOT OVER TIGHTEN**, see Diagram 13.

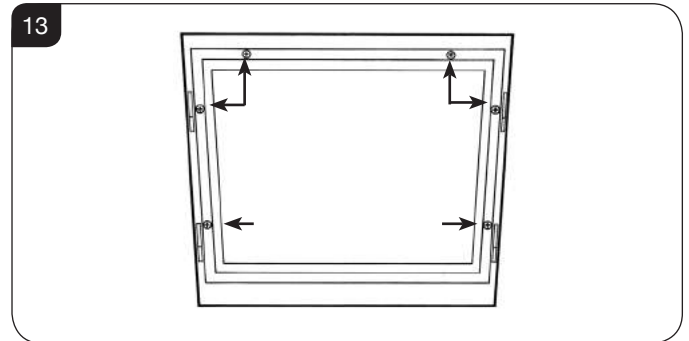

- 7.11 Replace ALL of the securing screws ensuring that a screw is present in all fixing slots.



UNDER NO CIRCUMSTANCES SHOULD THE APPLIANCE BE USED IF ANY OF THE FRAME RETAINING SCREWS ARE LOOSE OR MISSING.

NEVER OPERATE THE APPLIANCE WHEN THE GLASS FRAME IS REMOVED, OR THE GLASS IS BROKEN.

- 7.12 Push the door closed and turn the rosette until the catch holds the door firm, see Diagram 14.

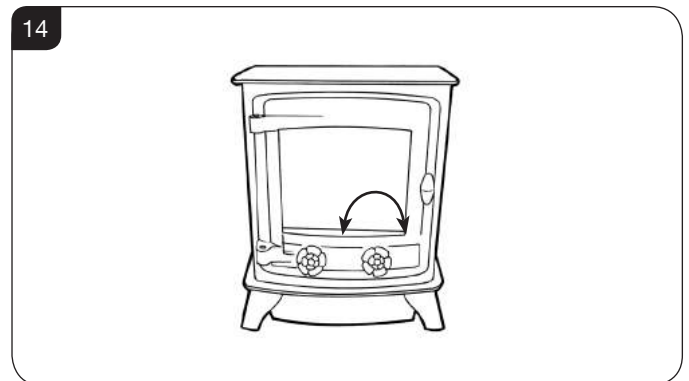

User Instructions

8. Flue Sure System

- 8.1 The appliance is fitted with the Flue Sure System, which will act to cut off the gas supply to the burners in the event of incorrect operation of the flue. If the system acts to cut off the gas supply, this indicates that there is insufficient flue pull. If this occurs a minimum of 10 minutes should be allowed before trying to relight. Continued operation of this safety device means there may be a serious problem with the flue system. A qualified gas engineer should inspect this.

DO NOT USE THE APPLIANCE UNTIL AN ENGINEER SAYS IT IS SAFE TO DO SO.

9. Flame Failure Device

- 9.1 This is a safety feature incorporated on this appliance which automatically switches off the gas supply if the pilot goes out and fails to heat the thermocouple.

IF THIS OCCURS DO NOT ATTEMPT TO RELIGHT THE APPLIANCE FOR 3 MINUTES.

10. Running In

- 10.1 During initial use of a new Yeoman appliance a strong odour will be encountered as various surface coatings become hot for the first time. Although these odours are harmless it is recommended that the appliance is operated on maximum for 4 to 8 hours in order to fully burn off these coatings. After this period the odours should then disappear.

If the odours persists, please contact your installer for advice.

- 10.2 During the first few hours of burning there may be discolouration of the flames. This will also disappear after a short period of use.

11. Servicing

- 11.1 The appliance must be serviced every 12 months by a qualified Gas Engineer. In all correspondence always quote the Model number and the Serial number which may be found on the Commissioning Checklist (Page 3).

12. Ventilation

- 12.1 Any purpose provided ventilation should be checked periodically to ensure that it is free from obstruction.

13. Installation Details

- 13.1 Your installer should have completed the commissioning sheet at the front of this book. This records the essential installation details of the appliance. In all correspondence always quote the Model number and Serial number.

14. Hot Surfaces

- 14.1 Parts of this appliance become hot during normal use. Regard all parts of the appliance as a 'working surface'.
- 14.2 Provide a suitable fire guard to protect young children and the infirm.

Installation Instructions

Technical Specification

Covering the following models:

Model	NATURAL GAS	LPG
Flat Top	YM581-239	YM581-402
Low Canopy	YM581-298	YM581-447

Model	Gas CAT.	Gas Type	Working Pressure	Aeration	Injector	Gas Rate m ³ /h	Input kW (Gross)		Country
							High	Low	
Exmoor	I ₂ H	Natural (G20)	20mbar	1mm x 6mm Ø	185	0.314	3.3	2.0	GB, IE
	I ₃ P	Propane (G31)	37mbar	6mm x 15mm	90	0.120	3.2	2	GB, IE
Efficiency Class 2 - 75%/ NOx Class 4									
Flue Size TOP/REAR EXIT 127mm ø									
Gas Inlet Connection Size = 8mm ø									
Minimum Flue Specification = T250/N2/O/D/1									
Maximum Flue Temp = 220°C									

i The net efficiency of this appliance has been measured as specified in EN613:2001 and the result after conversion to gross using the appropriate factor from Table E4 of SAP 2009 is 69%. The test data has been certified by Kiwa Nederland BV. The gross efficiency value may be used in the UK Government's Standard Assessment Procedure (SAP) for energy rating of dwellings.

Installation Instructions

Technical Specification

This appliance has been certified for use in countries other than those stated. To install this appliance in these countries, it is essential to obtain the translated instructions and in some cases the appliance will require modification. Contact Yeoman for further information.

PACKING CHECKLIST

Qty	Description	Fixing Kit containing:-
1 x	Appliance	1 x Instruction manual
1 x	Flue Blanking plate	
1 x	Flue In fill plate	
1 x	Log set*	
1 x	Log Guard	
*Packed in appliance		

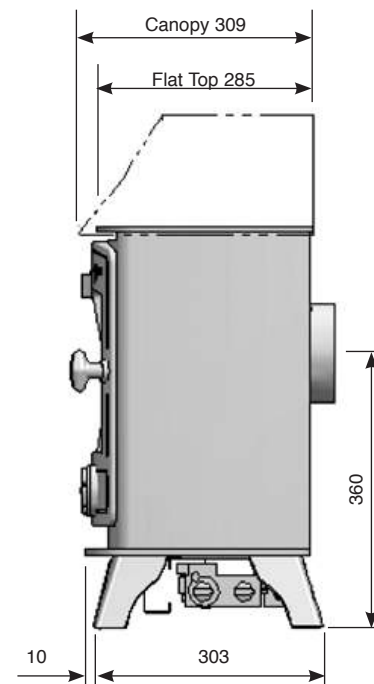
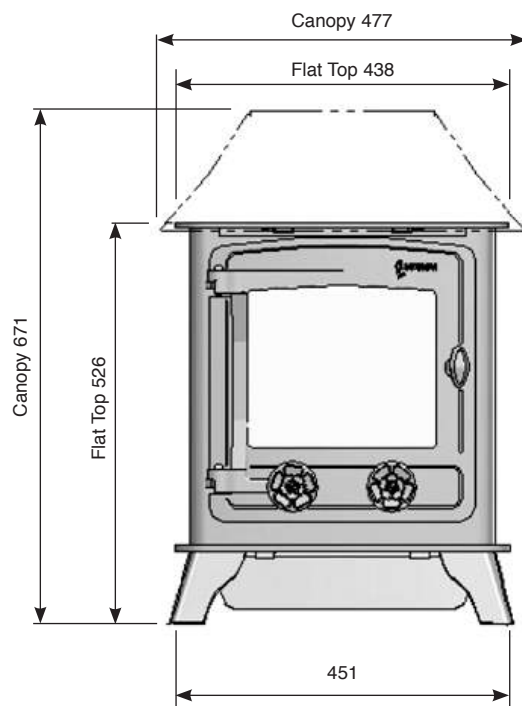
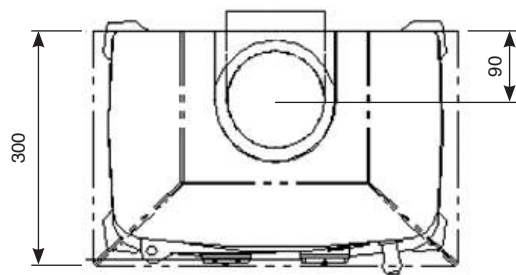

Installation Instructions

Site Requirements

1. Flue & Chimney Requirements

- 1.1 The chimney or flue system must comply with the rules in force, and must be a minimum of 127mm in diameter. (5").
- 1.2 The minimum flue height for the appliance must be 3 metres (10ft). Any horizontal flue run from the rear outlet must not exceed 100mm from the back of the appliance.
- 1.3 The chimney or flue must be free from any obstruction. Any damper plates must be removed or secured in the fully open position, and no restrictor plates fitted.
- 1.4 The chimney must be swept prior to the installation, but it need not be swept if it can be seen the chimney is clean and unobstructed throughout its entire length.
- 1.5 A5" (127mm) liner must be used if fitting the appliance into an existing brick built chimney. Larger lined flues can work, but in some instances could cause cold start flue problems resulting in nuisance shutdown. Lined flues above 7" (175mm) are not recommended.
- 1.6 Due to European chimney standards, new flue's and chimney's are described by their temperature, pressure and resistance to corrosion, condensation and fire. To assist in identifying the correct flue system, the minimum flue specification is shown in the Technical Specification. Existing chimneys are not covered by this system.

2. Flue Options

A range of Vitreous Enamel Gloss Black flue pipe is available to compliment the Exmoor. Please contact your Yeoman retailer for further information.

3. Gas Supply

THIS APPLIANCE IS INTENDED FOR USE ON A GAS INSTALLATION WITH A GOVERNED METER.

- 3.1 Before installation, ensure that the local distribution conditions (identification of the type of gas and pressure) and the adjustment of the appliance are compatible.
- 3.2 Ensure the gas supply delivers the required amount of gas and is in accordance with the rules in force.
- 3.3 Soft copper tubing and soft soldered joints can be used but must not be closer than 50mm to the base of the tray.
- 3.4 An independent means of isolating the gas pipe must be provided before the gas supply enters the appliance.
- 3.5 All supply gas pipes must be purged of any debris that may have entered prior to connection to the appliance.
- 3.6 The gas supply must be installed in a way that does not restrict the removal of the appliance for servicing and inspection.

4. Ventilation

IMPORTANT: Ensure any national ventilation requirements are taken into account during installation of the appliance.

UK ONLY:

The Exmoor has a nominal input not exceeding 7.0kW and does not normally require any additional permanent ventilation.

FOR THE REPUBLIC OF IRELAND REFER TO THE RULES IN FORCE FOR VENTILATION REQUIREMENTS.

5. Appliance Location

HEARTH INSTALLATION

- 5.1 Building Regulations state this appliance must stand on a non-combustible hearth that is at least 12mm thick and projects 50mm minimum from the base of the appliance in all directions, however Yeoman recommend the hearth extends to the following dimensions, see Diagram 1.

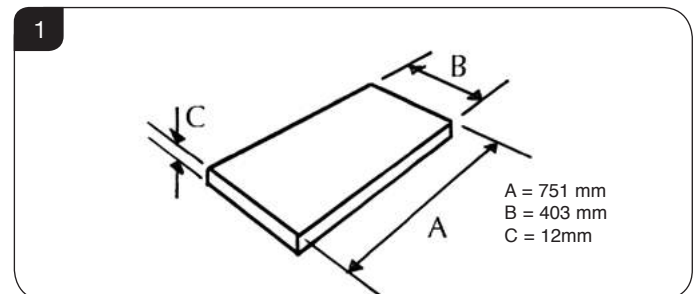

- 5.2 Do not install in a room that contains a bath or shower.

Installation Instructions

Site Requirements

MINIMUM CLEARANCE

- 5.3 The appliance is not suitable for installation against a combustible wall. All combustible materials must be removed from behind the appliance.
- 5.4 Ensure that all minimum clearances to combustible materials are complied with, see Diagrams 2 and 3.

The specified clearances provide the minimum distance to combustible materials. If the appliance is intended to be installed into a non-combustible opening the clearance to the **sides and above** the appliance can be reduced. However, it is recommended that the specified clearances are maintained irrespective of the materials used in the construction of the opening to allow adequate air flow and access to controls. **The clearance at the rear of the appliance must always be a minimum of 50mm.**

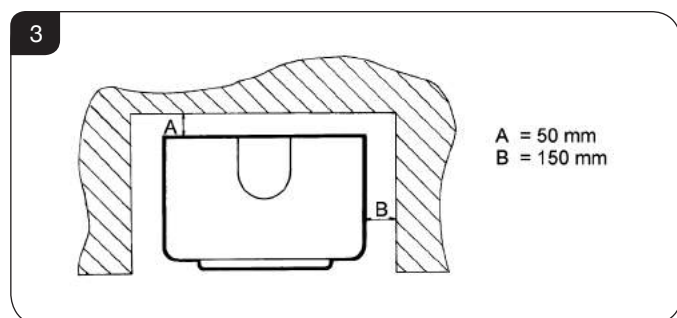
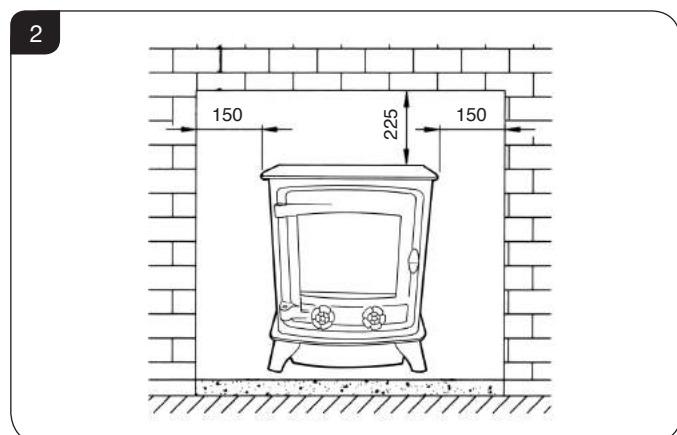

- 5.5 The above dimensions provide adequate clearance to combustible materials. It may be necessary to add additional clearance so that spillage tests can be performed when necessary.

Installation Instructions

1. Safety Precautions

- 1.1 For your own and other's safety, you must install this appliance according to local and national codes of practice. Failure to install the appliance correctly could lead to prosecution. **Read these instructions before installing and using this appliance.**
- 1.2 These instructions must be left intact with the user.
- 1.3 Do not attempt to burn rubbish on this appliance.
- 1.4 Keep all plastic bags away from young children.
- 1.5 Do not place any object on or near to the appliance and allow adequate clearance above the appliance.

IF THE APPLIANCE IS EXTINGUISHED OR GOES OUT IN USE, WAIT 3 MINUTES BEFORE ATTEMPTING TO RELIGHT THE APPLIANCE.

- 1.6 The appliance is fitted with the Flue Sure System, which will act to cut off the gas supply to the burners in the event of incorrect operation of the flue. If the system acts to cut off the gas supply, this indicates that there is insufficient flue pull. If this occurs a minimum of 10 minutes should be allowed before trying to relight. Continued operation of this safety device means there may be a serious problem with the flue system. A qualified gas engineer should inspect this.
- 1.7 Do not alter or tamper with the Flue Sure System. Use only genuine replacement parts when servicing the system - refer to the **Servicing Section, Replacing Parts.**

DO NOT USE THE APPLIANCE UNTIL AN ENGINEER SAYS IT IS SAFE TO DO SO.



IMPORTANT: REFER TO DATA BADGE AND TECHNICAL SPECIFICATION AT THE FRONT OF THE MANUAL TO ENSURE THE APPLIANCE IS CORRECTLY ADJUSTED FOR THE GAS TYPE AND CATEGORY APPLICABLE IN THE COUNTRY OF USE.

FOR DETAILS OF CHANGING BETWEEN GAS TYPES REFER TO SERVICING, SECTION 14, REPLACING PARTS.

Unpacking

- 1.8 Remove the appliance from its packaging, and check that it is complete and undamaged.

Put the loose ceramic parts to one side so that they are not damaged during installation.

2. Upgrading the Appliance

- 2.1 The appliance is fitted with a control valve that can easily be upgraded to battery powered remote control. There are two versions of this control which can be obtained through your local Yeoman stockist. There is no requirement for this upgrade to be carried out by an approved Gas engineer. However Yeoman recommend that this task is undertaken by a suitably competent person.
- 2.2 This upgrade can be fitted before or after installation but if side clearances are limited then it will be easier to upgrade the appliance before installation. Full instructions are included with the kit.

Standard Remote Control (PART NUMBER 8455)

- 2.3 This remote control can control the gas appliance after the pilot has been lit. It can turn the main burner on and regulate it from low through to high and back again. It can turn the main burner off leaving the pilot burning.

Thermostatic and Timer Remote Control (PART NUMBER 8456)

- 2.4 This remote control can control the gas appliance after the pilot has been lit.

MANUAL MODE

Can be used to turn the main burner on and manually regulate it from low through to high and back again. It can also be used to turn the main burner off leaving the pilot burning.

AUTO MODE

Will automatically regulate the room to a pre-set temperature.

TIMER MODE

Will turn the appliance on and off according to a pre-set programme and automatically regulate the room temperature during the two on periods.

Installation Instructions

3. Installation of the Appliance

- 3.1 Decide whether to use top or rear flue exit. The appliance is factory built for rear flue exit but it can be changed to top exit by swapping the flue spigot and blanking plate located on the appliance.
- 3.2 Position the appliance ensuring all appropriate clearances are observed.
- 3.3 Adjust the balance of the appliance using the bolts in the legs to make it level.

Fitting the Canopy

- 3.4 To fit the canopy to the top of the appliance slide the canopy over the top plate, see Diagram 1.

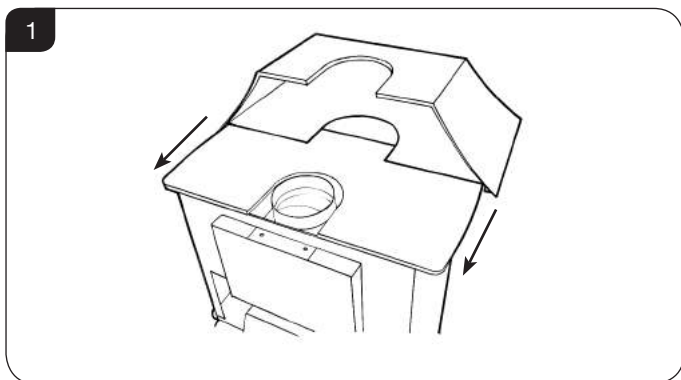

- 3.5 Make sure the appliance top fits into the guide along the bottom of the canopy, see Diagram 2.

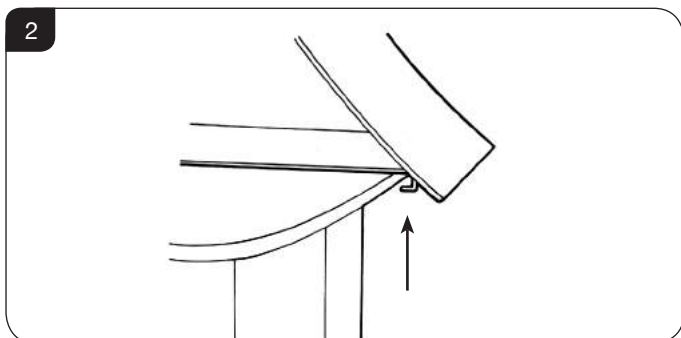

- 3.6 Ensure the canopy sits square on top of the appliance and the flue centres line up.
- 3.7 Push the canopy back until it hits the stop.
- 3.8 Make sure the canopy sits square on top of the appliance.
- 3.9 Having run the gas supply to the appliance **PURGE THE SUPPLY PIPE.** This is essential to expel any debris that can block the gas controls.

- 3.10 Connect the gas supply to the 8mm-compression elbow at the right-hand rear corner of the appliance. There is a cutout in the right-hand rear leg to enable a straight connection to the rear of the appliance, see Diagram 3.

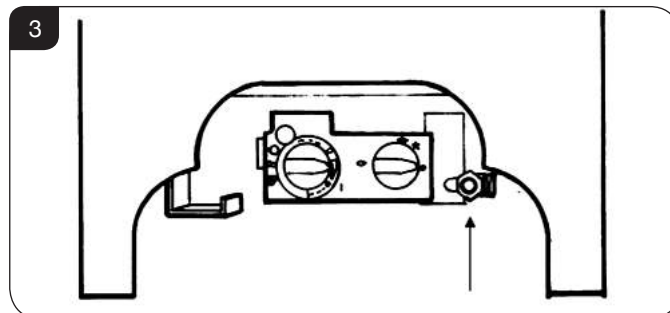

- 3.11 The flue system can now be connected to the appliance.
- 3.12 Ensure all joints are sealed with a fire resistant cement and use a self-tapping screw at the flue spigot joint.

4. Gas Soundness Pressure Check

- 4.1 Connect a suitable pressure gauge to the test point located on the inlet fitting and turn the gas supply on. Light the appliance and check all gas joints for possible leaks. Turn the appliance to maximum and check that the supply pressure is as stated on the databadge. Turn the gas off and replace the test point screw, turn the gas on and check the test point for leaks.

5. Removing the Door



IMPORTANT: THE OUTER PANNELLING OF THE APPLIANCE IS MADE FROM CAST IRON. USE CAUTION WHEN INSTALLING, REMOVING AND STORING AS THE COMPONENTS ARE HEAVY AND SHOULD BE HANDLED CAREFULLY.

- 5.1 To open the door and access the interior; turn the right-hand rosette 90°, see Diagram 4 and pull the door open.

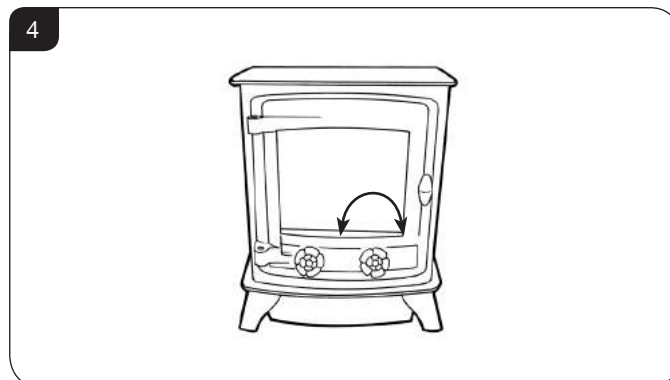

- 5.2 Remove the door casting assembly by removing the 2 hinge pins and lifting the door above the hinge blocks.

Installation Instructions

- 5.3 Remove the glass frame by undoing the 6 screws and carefully lifting the frame clear, see Diagram 5.

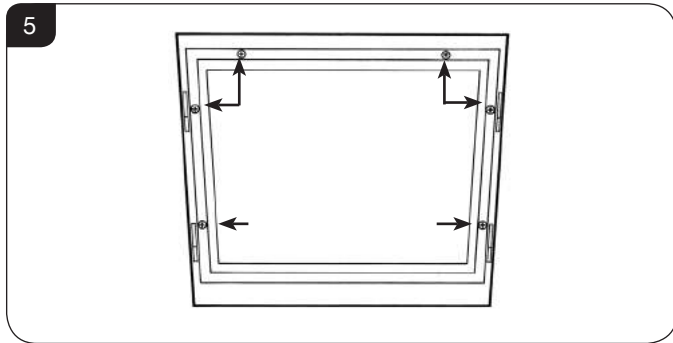

- 5.4 Place carefully to one side.

6. Arrangement of Fuel Bed

Advice on handling and disposal of fire ceramics



The fuel effect and side panels of this appliance are made from Refractory Ceramic Fibre (RCF), a material which is commonly used for this application.

Protective clothing is not required when handling these articles, but we recommend you follow normal hygiene rules of not smoking, eating or drinking in the work area and always wash your hands before eating or drinking.

To ensure that the release of RCF fibres are kept to a minimum, during installation and servicing a HEPA filtered vacuum is recommended to remove any dust accumulated in and around the appliance before and after working on it. When servicing the appliance it is recommended that the replaced items are not broken up, but are sealed within heavy duty polythene bags and labelled as RCF waste.

RCF waste is classed as stable, non-reactive hazardous waste and may be disposed of at a licensed landfill site.

Excessive exposure to these materials may cause temporary irritation to eyes, skin and respiratory tract; wash hands thoroughly after handling the material.

7. Log Layout

LOGS MUST BE POSITIONED ACCORDING TO THE FOLLOWING INSTRUCTIONS TO GIVE THE CORRECT FLAME EFFECT

All logs can be identified by a letter (A - E) on their underside. Logs, B and E also have holes to locate each onto a burner stud.

- 7.1 Ensure the burner tray is clean and free from any debris, see Diagram 6.

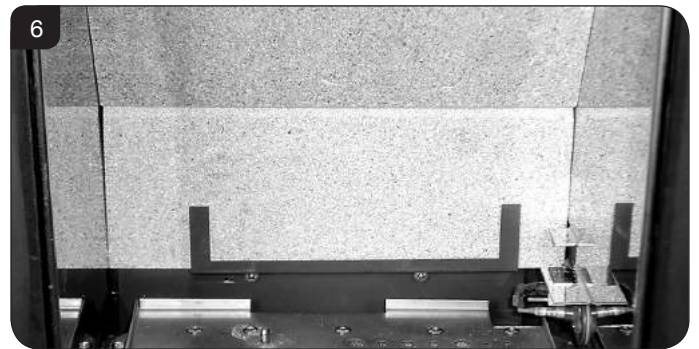

- 7.2 Place Log A on the higher rear bracket and push up against the back panel, see Diagram 7.

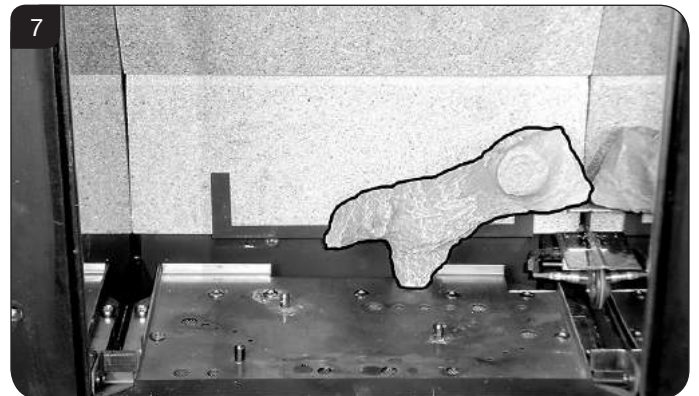

- 7.3 Place Log B over the two middle studs on the burner tray, see Diagram 8.

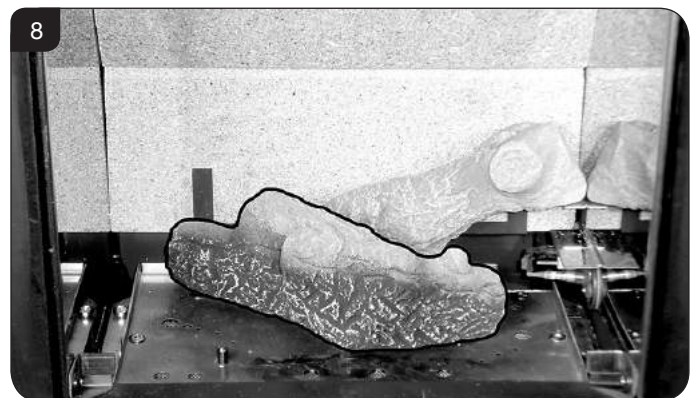

Installation Instructions

- 7.4 Place Log E onto the stud and behind the tag on the left hand side of the burner tray. Rest against Log B, see Diagram 9.

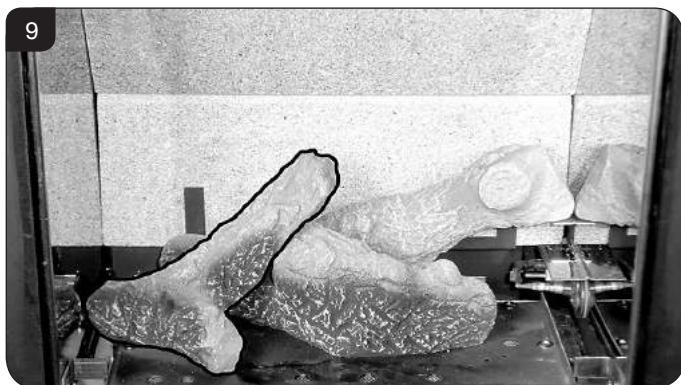

- 7.5 Place the small Ember at the front left of the firebox, against the rear of the log support bracket to obscure the reflection of the burner screw.

Place the larger Ember on the lower bracket above the pilot on the right hand side with the thicker edge facing the front and flat edges to the base and side, see Diagram 10.

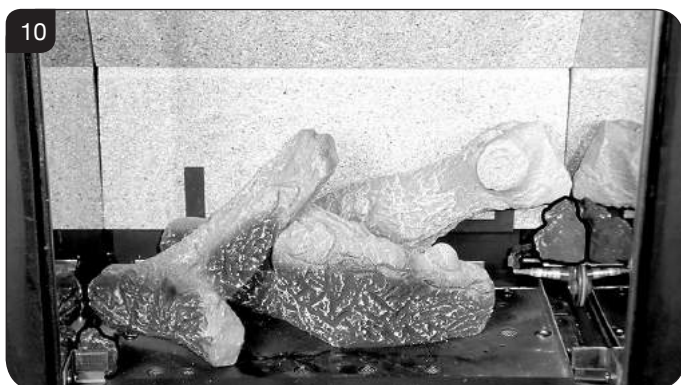

- 7.6 Log C rests on the cutout on Log E and is pushed up to the side and rear of the firebox, see Diagram 11.



- 7.7 Place the pointed bottom of log D into the corner of the burner tray and rest on the location stud on log B, see Diagram 12.



- 7.8 Use some of the Embaglow provided and cover the ports in the burner tray with a liberal amount of fibres. Use a small piece in front of the log on the left hand side and a long strip in front of log B, see Diagram 13.

NOTE: It is not necessary to use all of the Embaglow.



- 7.9 Lower log guard into position, see Diagram 14.



Installation Instructions

8. Completion of Assembly

- 8.1 Ensure that the rope seal on the back of the glass frame is intact and replace the 6 screws working from the top down. Tighten the screws evenly **DO NOT OVER TIGHTEN**, see Diagram 15.

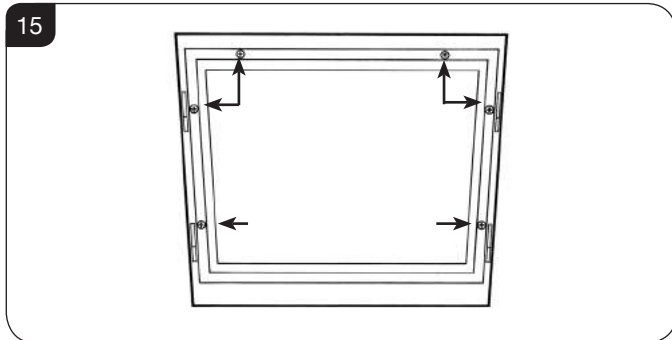

- 8.2 Replace ALL of the securing screws ensuring that a screw is present in all fixing slots.

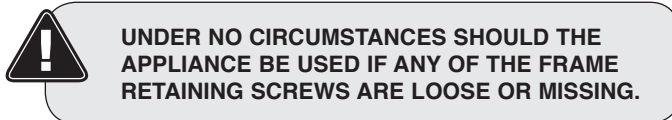

UNDER NO CIRCUMSTANCES SHOULD THE APPLIANCE BE USED IF ANY OF THE FRAME RETAINING SCREWS ARE LOOSE OR MISSING.

NEVER OPERATE THE APPLIANCE WHEN THE GLASS FRAME IS REMOVED, OR THE GLASS IS BROKEN.

- 8.3 Push the door closed and turn the rosette until the catch holds the door firm, see Diagram 16.

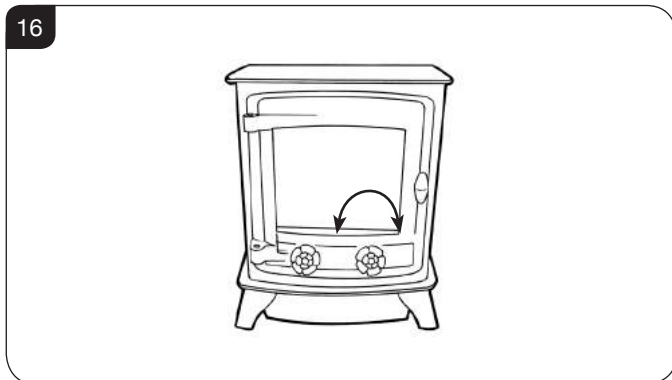

9. Operating the Appliance

- 9.1 The control valve is at the foot on the right-hand side of the appliance. It has two controls, see Diagram 17:

1. The right-hand knob controls the pilot ignition.
2. The left-hand knob controls the main burner.

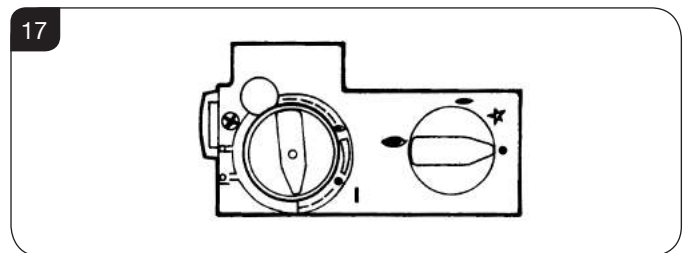

- 9.2 Refer to separate instructions if your appliance is upgraded to include battery remote control. The instructions below apply whether or not you have the remote upgrade.

Lighting the Pilot

- 9.3 To start the left-hand and right-hand control knobs must both point to off (●):
- 9.4 Press in the right-hand control knob and rotate anti-clockwise until a click is heard. Continue to press in. The knob points to the pilot (←).
- 9.5 Keep the knob depressed for 10 seconds before releasing. The pilot remains lit.

The pilot is lit.

Repeat the above steps if the pilot does not stay lit.

NOTE: If the pilot goes out, the Interlock system prevents you lighting again for a short period.

- 9.6 If, after repeating the above steps the pilot does not light, contact your Retailer or Installer.
- 9.7 Turn the right-hand knob to the left to main burner setting (→).

Adjusting the Flame height

- 9.8 You can now adjust the flame height and temperature using the left-hand control knob.
- 9.9 Turn the left-hand knob anti-clockwise to increase the flame height.
- 9.10 Turn clockwise to decrease the height.



IMPORTANT: YELLOW FLAMES TYPICALLY APPEAR WHEN THE APPLIANCE HAS REACHED NORMAL OPERATING TEMPERATURE. THIS CAN TAKE UP TO 30 MINUTES.



WARNING: IF THE APPLIANCE FAILS TO LIGHT OR BECOMES EXTINGUISHED IN USE, WAIT 3 MINUTES BEFORE ATTEMPTING TO RELIGHT.

1. Commissioning

- 1.1 Close all doors and windows in the room.
- 1.2 Ignite the appliance and operate on maximum for 10 minutes.
- 1.3 Position a lighted smoke match just inside the draught diverter opening at the rear of the appliance.
- 1.4 Check all smoke is drawn into the opening, see Diagram 1.

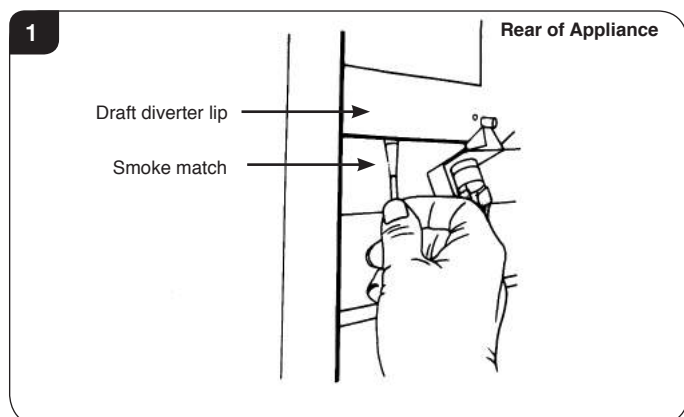

- 1.5 If there is any doubt, run the appliance for a further 10 minutes, and repeat the test.
- 1.6 If there are any extractor fans in adjacent rooms, the test must be repeated with the fans running on maximum and interconnecting doors open.

IF SPILLAGE PERSISTS, DISCONNECT THE APPLIANCE AND SEEK EXPERT ADVICE.

- 1.7 Complete the Commissioning Checklist at the front of this manual covering:
 - Flue checks
 - Gas checks
 - Log layout - flame picture
- 1.8 Ensure all safety checks listed in the Commissioning Section are completed, paying particular attention to the glass panel checks and securing of the glass frame.
- 1.9 Upon completion of the commissioning and testing of the installation and correct operation of the appliance, the installer must instruct the user how to operate the appliance.
- 1.10 Guide the user through the User Instructions paying particular attention to:
 - a) Regular servicing (Section 11 of the User Instructions).
 - b) Ventilation (Section 12 of the User Instructions) - point out the ventilation positions where applicable.
 - c) Hot surfaces (Section 14 of the User Instructions).

Servicing Instructions

Servicing/Fault Finding Charts

1. Servicing Requirements

IMPORTANT – The glass panel on this appliance should be checked for any signs of damage on the front face of the glass panel (scratches, scores, cracks or other surface defects). If damage is observed, the glass panel must be replaced and the appliance must not be used until a replacement is installed. Under no circumstances should the appliance be used if any damage is observed. Please isolate the appliance until a replacement glass panel has been obtained and installed. Replacement glass panels can be purchased from Yeoman via the retailer from which the appliance was purchased or any other Yeoman distributor.

This appliance must be serviced at least once a year by a competent person.

All tests must be carried out in accordance with the current Gas Safe recommendations.

1.1 Before Testing:

- Conduct a gas soundness test for the property ensuring there are no leaks before servicing.
- Check the operation of the appliance before testing.

1.2 Special checks:

- Clean the burner using a vacuum cleaner with a soft brush attachment. Ensure all debris is removed from the burner ports.
- Clean away lint or fluff from the pilot.
- Clean away lint or fluff from under the burner.
- Check the spark gap on the pilot is correct, see Diagram 1.
- Ensure that the glass frame is secured correctly and that all retaining screws are in place.

1.3 Correct any faults found during the initial test.

1.4 Re-commission the appliance in accordance with Commissioning Procedures.

1.5 Advise the customer of any remedial work undertaken.

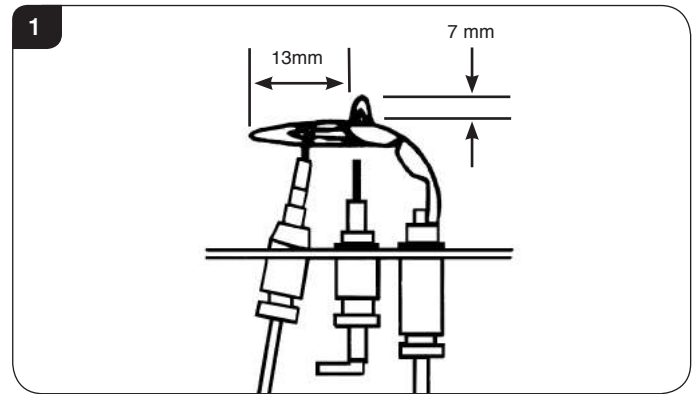

IGNITION FUNCTIONAL CHECK 1

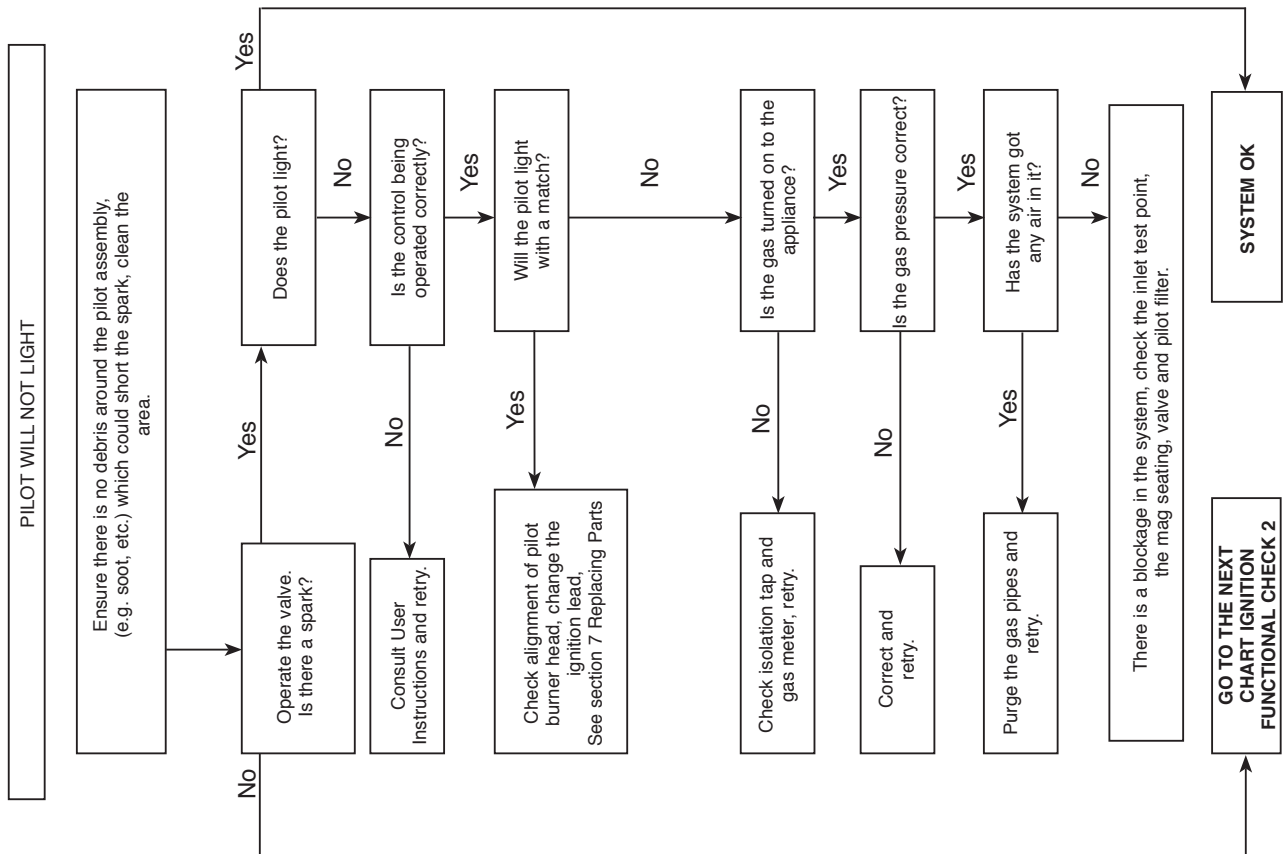

Servicing Instructions

Fault Finding Charts

FLAME FAILURE FUNCTIONAL CHECK 3

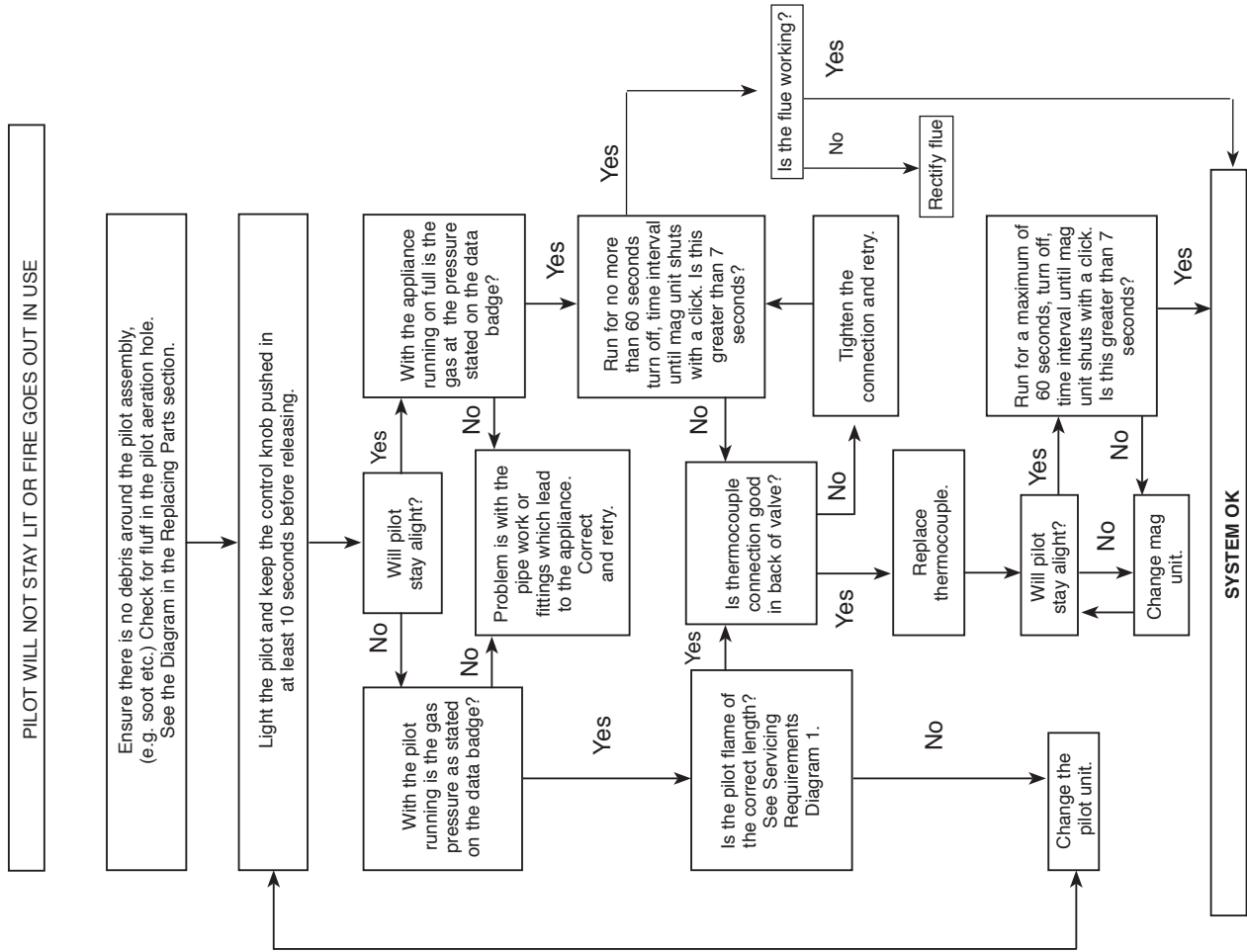

IGNITION FUNCTIONAL CHECK 2

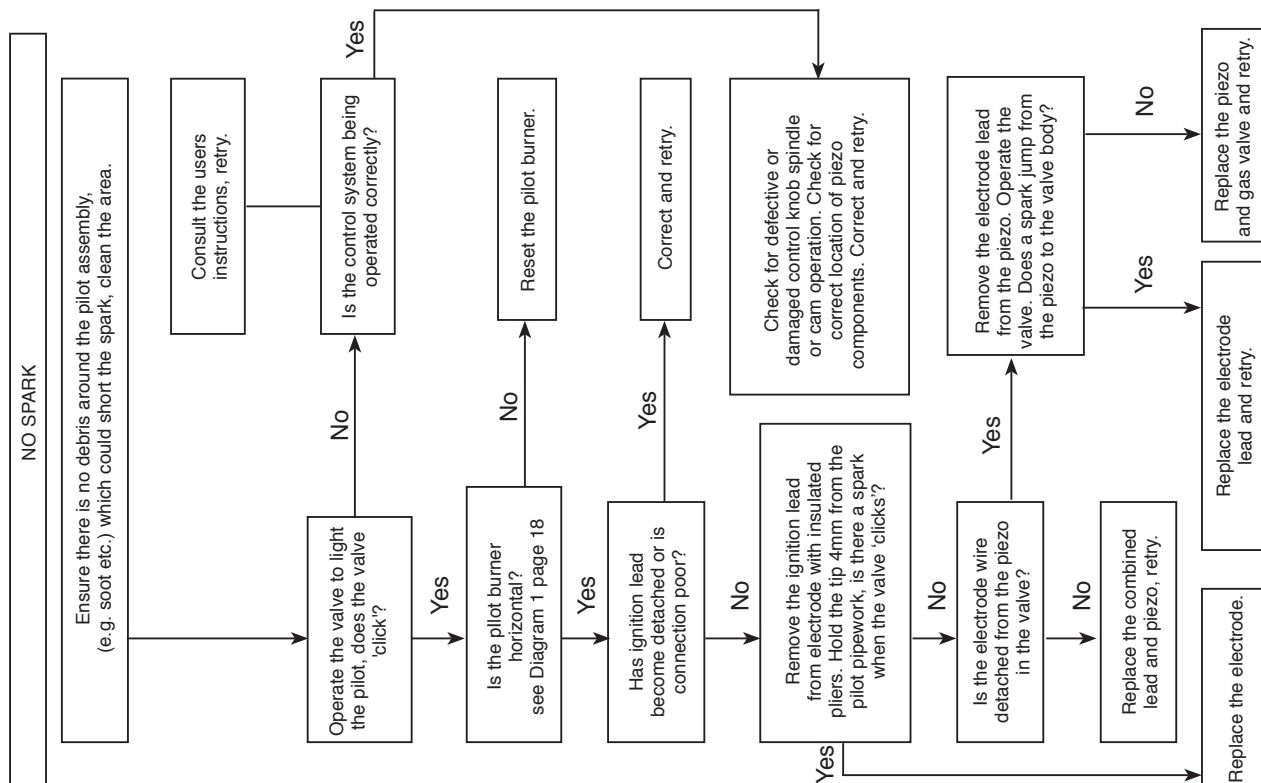

Servicing Instructions - Replacing Parts

1. General

- 1.1 All main components can be replaced without removing the appliance from its installation.
- 1.2 Ensure the appliance and surrounds are cool before servicing.

IT IS ESSENTIAL THAT THE GAS SUPPLY TO THE APPLIANCE IS TURNED OFF AT THE ISOLATION DEVICE BEFORE PROCEEDING FURTHER.

2. Removing the Door



IMPORTANT: THE OUTER PANNELLING OF THE APPLIANCE IS MADE FROM CAST IRON. USE CAUTION WHEN INSTALLING, REMOVING AND STORING AS THE COMPONENTS ARE HEAVY AND SHOULD BE HANDLED CAREFULLY.

- 2.1 To open the door and access the interior; turn the right-hand rosette 90°, see Diagram 1 and pull the door open.

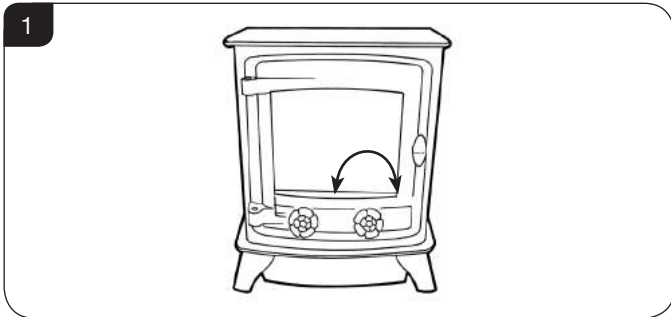

- 2.2 Remove the door casting assembly by removing the 2 hinge pins and lifting the door above the hinge blocks.

3. Window Frame Assembly

- 3.1 Remove the glass frame by undoing the 6 screws and carefully lifting the frame clear, see Diagram 2.

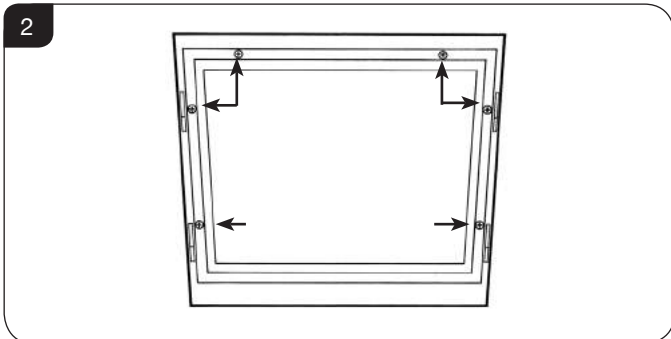

- 3.2 Place carefully to one side.

- 3.3 Lift out the log guard and carefully remove the ceramic fuel bed components.

- 3.4 Refit in reverse order.

The glass frame must be refitted to the appliance following cleaning or servicing.

- 3.5 Ensure that the rope seal on the back of the glass frame is intact and replace the 6 screws working from the top down. Tighten the screws evenly **DO NOT OVER TIGHTEN**, see Diagram 2.

- 3.6 Replace ALL of the securing screws ensuring that a screw is present in all fixing slots.



UNDER NO CIRCUMSTANCES SHOULD THE APPLIANCE BE USED IF ANY OF THE FRAME RETAINING SCREWS ARE LOOSE OR MISSING.

NEVER OPERATE THE APPLIANCE WHEN THE GLASS FRAME IS REMOVED, OR THE GLASS IS BROKEN.

4. Baffle & Ceramic Liners

- 4.1 To access the burner tray and interior workings of the appliance it may be necessary to remove the baffle and the liners.

- 4.2 There is no requirement to remove the baffle for servicing.

LINERS

- 4.3 The burner can be accessed without the need to remove the side liner panels. If they need to be taken out then first remove the screws securing the two brackets on either side of the firebox. The panels will now slide forward, see Diagram 3.

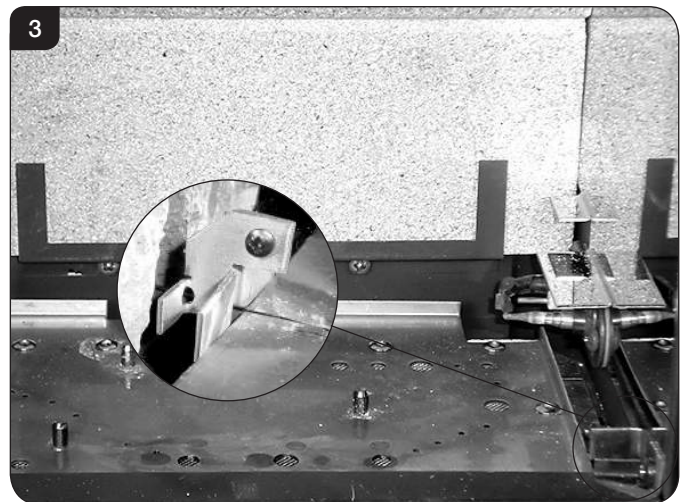

Servicing Instructions - Replacing Parts

- 4.4 Gently lift the upper rear liner and pull forwards. With the panel raised it should be possible to remove from the liner brackets, see Diagram 4.

Note: It may be necessary to use a flat object like a screwdriver to separate the two panels.

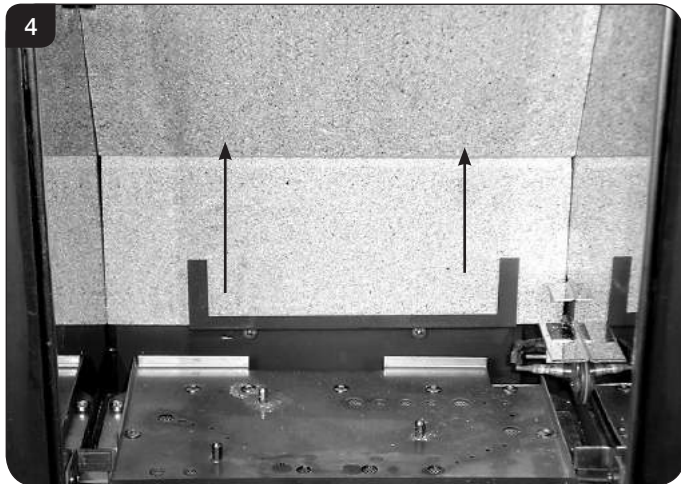

- 4.5 Slide the lower rear liner up and out of the lower bracket, see Diagram 5.

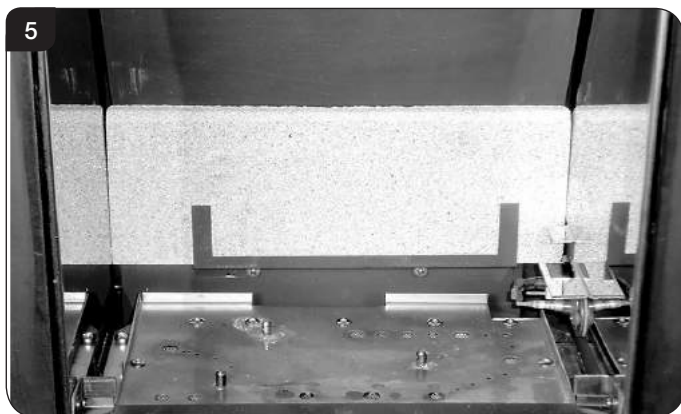

- 4.6 Replace all parts in reverse order ensuring the cutouts in the rear of the lower panel fit over the screws on the back of the firebox, see Diagram 6.

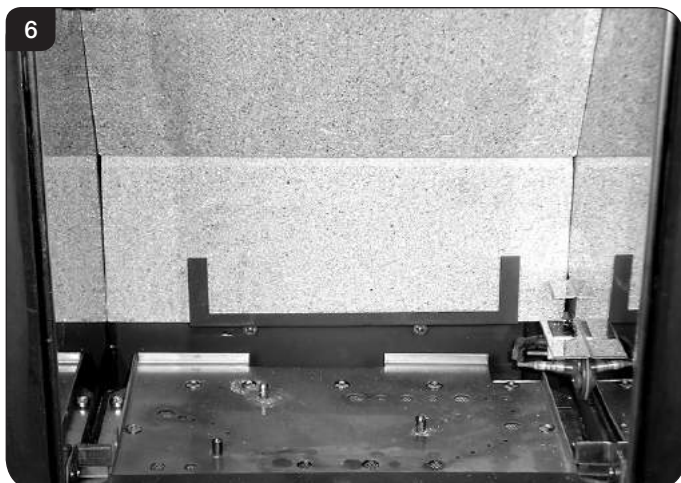

5. Main Burner

- 5.1 To replace the main burner:

Remove the baffle and enamel liners, see Section 4.

- 5.2 Remove the three securing screws from the edges of the burner, see Diagram 7.

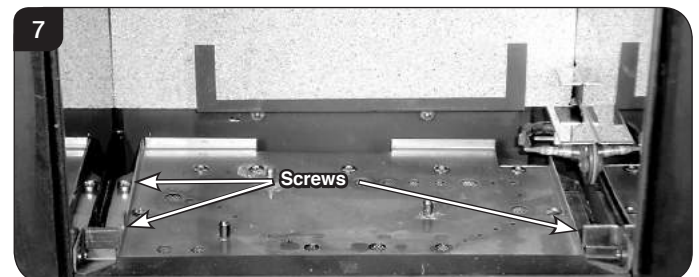

- 5.3 Slide the burner fully to the right whilst lifting the Left Hand side clear of the bracket, see Diagram 8.



- 5.4 Slide the burner back to the left and out of its location. **IMPORTANT: Take care when removing the burner not to damage the ceramic pad with the pilot unit attached.**

Refit in reverse order.

Servicing Instructions - Replacing Parts

6. Pilot Unit

- 6.1 The pilot assembly consists of five components, which can be individually replaced:
- 6a) Pilot burner bracket
 - 6b) Pilot injector
 - 6c) Electrode
 - 6d) Thermocouple
 - 6e) Gasket
- 6.2 Turn the gas supply off at the isolation device, remove the door and place to one side, carefully remove the ceramic fuel bed components.

6a. Pilot Burner Bracket

- 6.3 Remove the 2 fixing screws from the pilot bracket, see Diagram 9. Gently draw the assemble away from the firebox to give access to the nuts and ignition lead.
- NOTE: TAKE CARE NOT TO DAMAGE THE GASKET.**

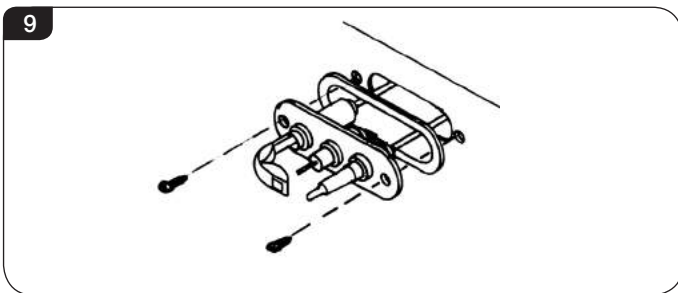

6b. Pilot Injector

- 6.4 Undo the compression nut on the pilot feed pipe and withdraw the injector which will be hooked onto the olive. When replacing an injector always make sure it is hooked onto the olive before inserting it into the pilot burner, see Diagram 10.

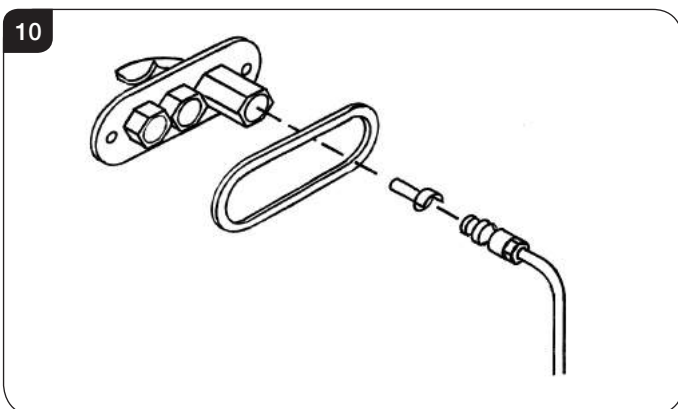

6c. Electrode

- 6.5 Disconnect the ignition lead and undo the retaining nut. The electrode can now be removed, note the orientation of the electrode terminal when reassembling, see Diagram 11.

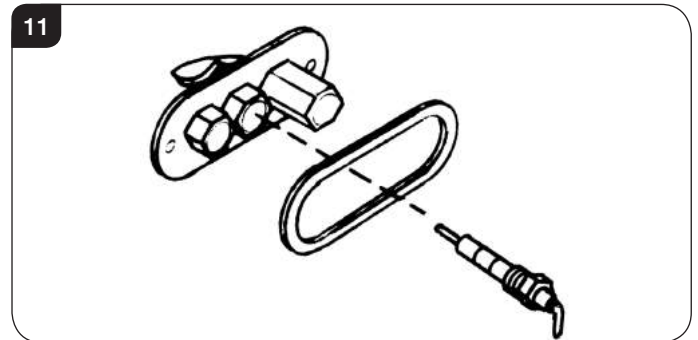

6d. Thermocouple

- 6.6 Undo the retaining nut and withdraw the thermocouple. Undo the thermocouple from the back of the gas valve, see Diagram 12. Reassemble in reverse order. Do not overtighten.

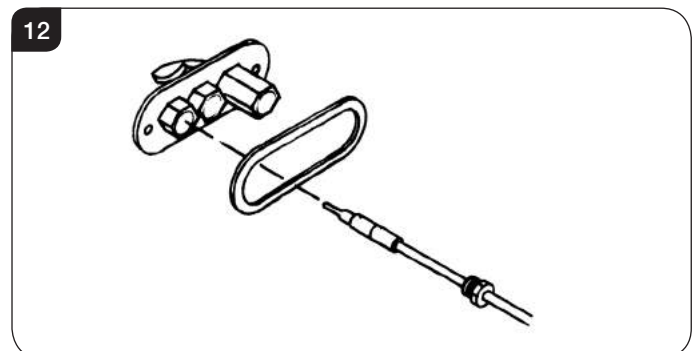

6e. Gasket

- 6.7 Disconnect all the above components and withdraw the gasket. If it is damaged, replace with a new item. Always replace the gasket first when reassembling the pilot components.

Servicing Instructions - Replacing Parts

7. Ignition Lead

- 7.1 Follow the Pilot Unit instruction to access the back of the pilot assembly.
- 7.2 Disconnect the ignition lead from the electrode.
- 7.3 Remove the front cover from the control valve by removing the retaining screw, Diagram 13 and gently levering clear with flat bladed screwdriver, see Diagram 14.

NOTE: There is a small cylindrical metal spacer inside the cover, this must be kept and replaced on the fixing screw on re-assembly.

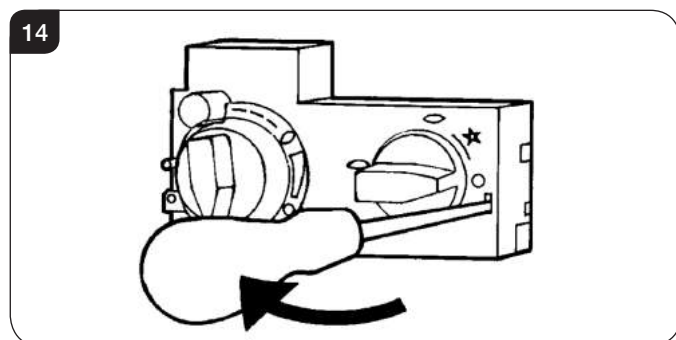
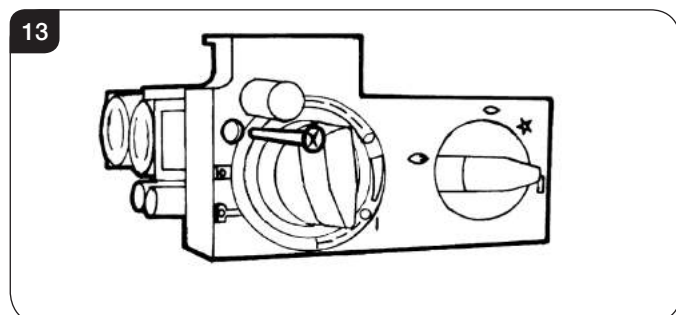

- 7.4 Disconnect the other end of the ignition lead from the valve body noting the route of the ignition lead.
- 7.5 Replace with a new ignition lead following the same route as the old one.
Replace the valve cover and the pilot assembly.
- 7.6 Check operation of the new ignition lead.

8. Piezo

- 8.1 The piezo assembly used on this appliance is not serviceable and is unlikely to fail.
- 8.2 **If a new piezo is required it will be necessary to change the valve, see Section 9.**

9. Gas Valve

- 9.1 To remove the valve turn off the gas supply at the isolation device.
- 9.2 Disconnect the 2 x 8mm and 1 x 4mm gas pipe fittings at the back of the gas valve, see Diagram 15 (A).
- 9.3 Disconnect the thermocouple, see Diagram 15 (B).

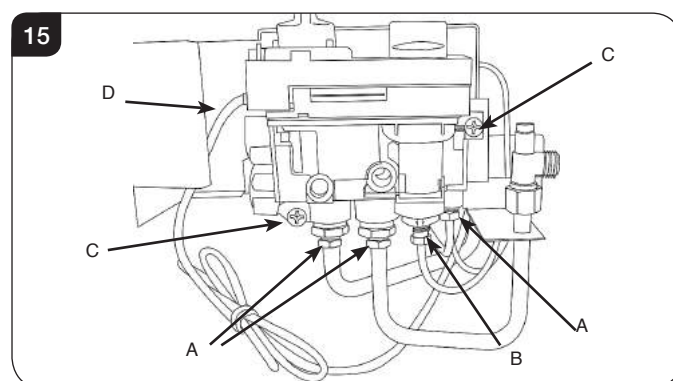

- 9.4 Disconnect the ignition lead from the gas valve, see Diagram 15 (D)
- 9.5 Remove the cover, see Section 7.3.
- 9.6 Undo the two bolts securing the gas valve to the appliance and remove the valve, see Diagram 15 (C).
- 9.7 Replace in reverse order.
- 9.8 Check all joints for gas leaks and check operation of the thermocouple and ignition lead.

Servicing Instructions - Replacing Parts

10. Magnetic Safety Valve

- 10.1 Turn the gas supply off at the isolation device.
- 10.2 Undo the thermocouple connection from the back of the gas valve, see Diagram 16 (A).
- 10.3 Pull the sensor leads clear and remove the interrupter block, see Diagram 16 (B).
- 10.4 Undo the magnetic valve-retaining nut from the back of the control valve, see Diagram 16 (C).
- 10.5 Gently tap out the magnetic valve and replace with a new unit.
- 10.6 Replace the retaining nut and tighten.

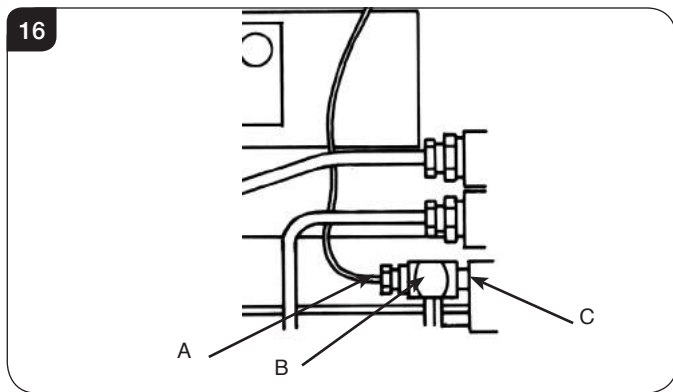

- 10.7 Reassemble the interrupter block and leads and secure the thermocouple connection in the rear of the gas control. (Do not overtighten).
- 10.8 Turn the gas supply on and check the entire pipework and valve joints for any leaks.

11. Main Injector

- 11.1 To remove the main injector turn off the gas supply at the isolation device.
- 11.2 Remove the main burner, see Section 5.
- 11.3 Undo the compression nuts from the feed pipe and the gas valve under the appliance.
- 11.4 Working from inside the firebox remove the lock nut from the injector, see Diagram 17.

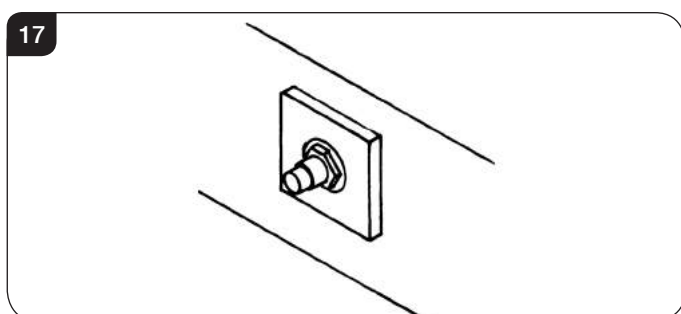

- 11.5 Extract the injector with the feed pipe from beneath the appliance.
- 11.6 Holding the injector with a spanner:
- 11.7 Undo the feed pipe. **Note the orientation of the Injector.**
- 11.8 Re-assemble in reverse order.
- 11.9 Turn on the gas supply and check for leaks.

12. Flue Sure System

- 12.1 Open the door and remove the ceramics, placing them carefully to one side.
- 12.2 Undo the two screws in the back of the firebox and carefully withdraw the bracket, see Diagram 18 and 19.

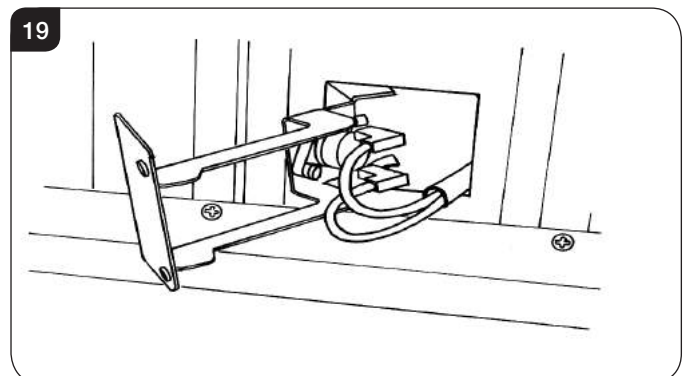
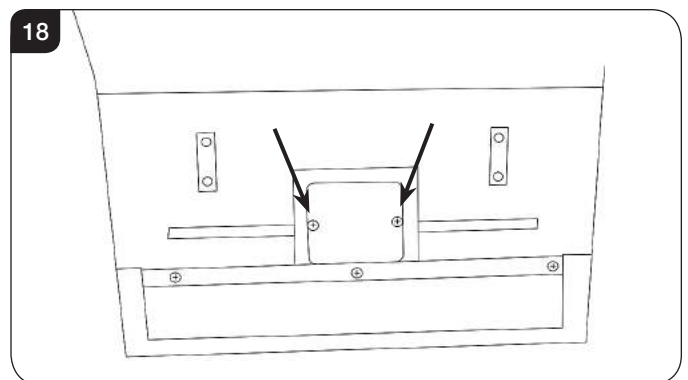

- 12.3 Disconnect the two sensor wires.
- 12.4 Undo the two retaining screws.
- 12.5 Remove the sensor and the two plastic spacers, see Diagram 20.

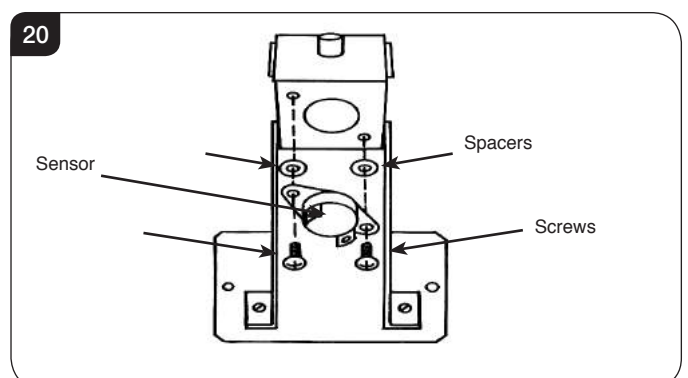

Servicing Instructions - Replacing Parts

- 12.6 Refit the new sensor ensuring the plastic spacers are located between the bracket and the sensor.
- 12.7 Refit the leads.
- 12.8 Feed the cable back through the hole as you replace the bracket.
When the bracket is located correctly it sits flush with the back panel without force. If not positioned correctly the bracket sits at an angle, see Diagram 21.

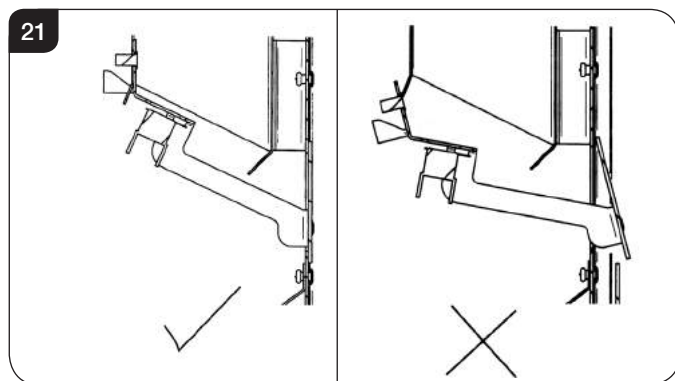

13. Primary Aeration Plate

NOTE: Not all models have aeration plates. Please refer to the Technical Specification.

- 13.1 To replace the primary aeration plate turn off the gas supply at the isolation device.
- 13.2 Remove the burner, see Installation Instructions, Replacing Parts, Section 5.
- 13.3 Detach the aeration plate from the venturi, see Diagram 22.

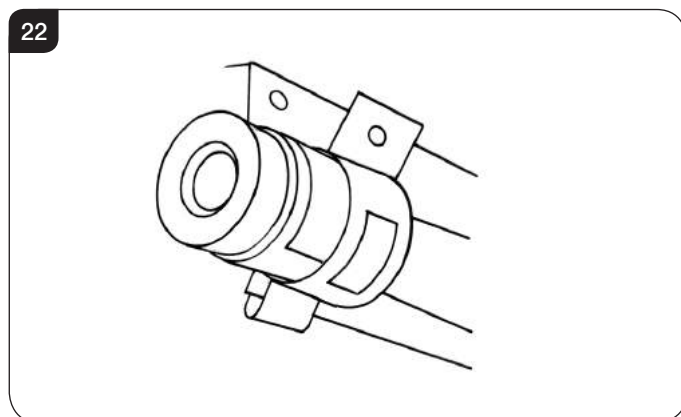

- 13.4 Reassemble in reverse order.
NOTE: Even if no aeration plate is required, the small screw must be replaced.

14. Changing Between Gas Types

A kit of parts is available for this - Contact your Gazco retailer for further information.

Always quote the Model number and Serial number when ordering any spare parts.

15. Control Upgrade

See Installation Instructions, Section 2.

Servicing Instructions - Replacing Parts

16. Spare Parts List - Exmoor

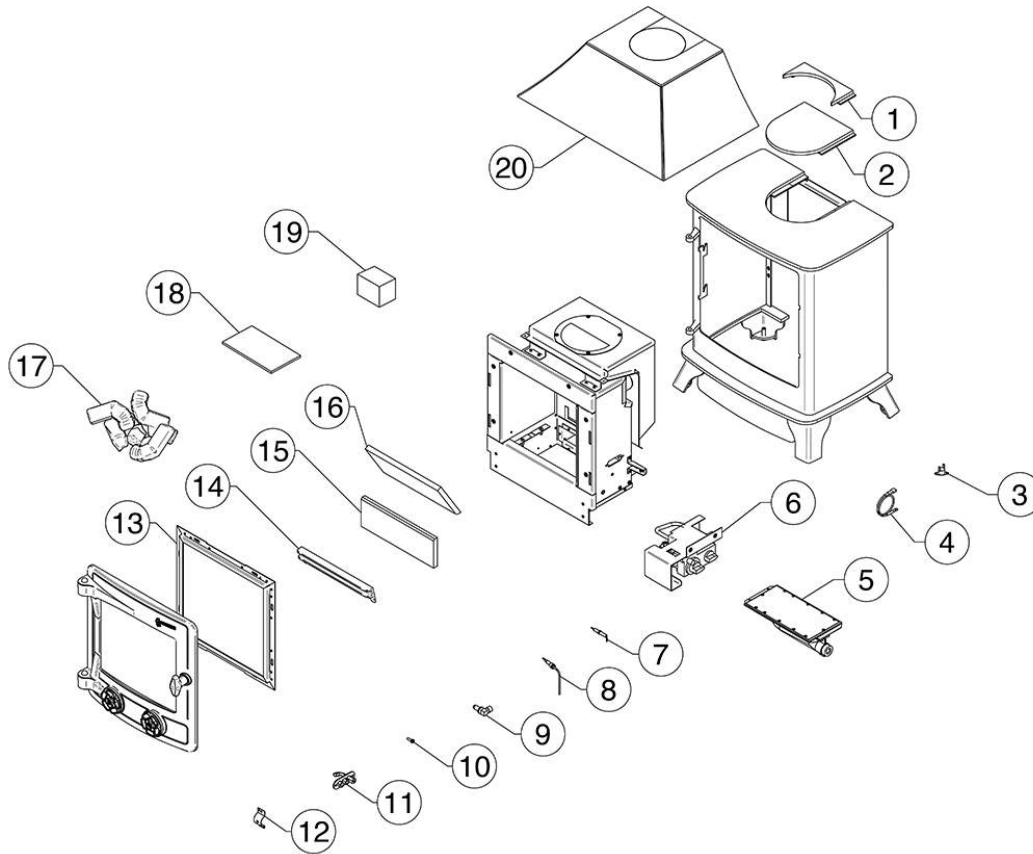

No.	Component	Part Code		
		Natural Gas	LPG	Quantity
1	Flue Infill Plate	YM-YA97502§		1
2	Flue Blanking Plate	YM-YA97010		1
3	Flue Sensor	EL0001		1
4	Flue Sensor Lead	EL0064		2
5	Burner Assembly	GZ12756	GZ12757	1
6	Control Assembly	B0213		1
7	Pilot Electrode	PI0053		1
8	Thermocouple	PI0010		1
9	Injector	IN0040 - Size 185	IN0071 - Size 90	1
10	Hook Jet Injector	PI0026	PI0015	1
11	Pilot Burner Body	PI0051		1
12	Aeration Cover	GZ9708	GZ2016	1
13	Glass Assembly	GZ7020		1
14	Log Retainer	CA0807		1
15	Rear Ceramic Panel	CE1560		1
16	Top Ceramic Panel	CE1561		1
17	Log Set	CE1559		1
18	Instruction Manual	PR2244		1
19	Embaglow	GZ8471		1
20	Canopy	YM-A9031LC		1

Due to continual technical improvements please check with your Yeoman retailer for the most up to date parts lists.

Servicing Instructions - Replacing Parts

16. Spare Parts List - Control Assembly



No.	Component	Part Code	Quantity
1	Control Valve	GC0088K	1
2	Control Valve Cover	GC0087	1
3	Mag. Unit	GC0166	1
4	Micro Switch and Screw	EL0241	1
5	Standard Handset	EL0239	1
6	Thermostatic Handset	EL0240	1
7	Standard Receiver	EL0235	1
8	Thermostatic Receiver	EL0236	1
9	Thermostatic Receiver Cable	EL0238	1
10	Standard Receiver Cable	EL0237	1
11	Geared Motor	EL0234	1
12	Ignition Lead	GC0090	1

Service Records

1ST SERVICE

Date of Service
Next Service Due
Signed
Retailer's Stamp/Gas Safe Registration Number

3RD SERVICE

Date of Service
Next Service Due
Signed
Retailer's Stamp/Gas Safe Registration Number

5TH SERVICE

Date of Service
Next Service Due
Signed
Retailer's Stamp/Gas Safe Registration Number

7TH SERVICE

Date of Service
Next Service Due
Signed
Retailer's Stamp/Gas Safe Registration Number

9TH SERVICE

Date of Service
Next Service Due
Signed
Retailer's Stamp/Gas Safe Registration Number

2ND SERVICE

Date of Service
Next Service Due
Signed
Retailer's Stamp/Gas Safe Registration Number

4TH SERVICE

Date of Service
Next Service Due
Signed
Retailer's Stamp/Gas Safe Registration Number

6TH SERVICE

Date of Service
Next Service Due
Signed
Retailer's Stamp/Gas Safe Registration Number

8TH SERVICE

Date of Service
Next Due
Signed
Retailer's Stamp/Gas Safe Registration Number

10TH SERVICE

Date of Service
Next Service Due
Signed
Retailer's Stamp/Gas Safe Registration Number



Yeoman Limited, Osprey Road, Sowton Industrial Estate, Exeter, Devon, England EX2 7JG
Technical Customer Services: (01392) 261950 Fax: (01392) 261951
E-mail: yeoman@gazco.com

A member of the Stovax Group
E & O E