



Yeoman CL

Free Standing Stove Range



Instructions for Use, Installation & Servicing

For use in GB & IE (Great Britain & Republic of Ireland).

IMPORTANT

THE OUTER CASING, FRONT AND GLASS PANEL BECOME EXTREMELY HOT DURING OPERATION AND WILL RESULT IN SERIOUS INJURY AND BURNS IF TOUCHED. IT IS THEREFORE RECOMMENDED THAT A FIREGUARD COMPLYING WITH BS 8423:2002 IS USED IN THE PRESENCE OF YOUNG CHILDREN, THE ELDERLY OR INFIRM.

Do not attempt to burn rubbish in this appliance.

Please read these Instructions carefully before installation or use.

Keep them in a safe place for future reference and when servicing the fire.

The commissioning sheet found on page 3 of these instructions should be completed by the Installer.

Contents

Yeoman CL - Freestanding Stove Range

Covering the following models:

Models: YM-CL3MF1/ YM-CL5W1/ YM-CL5MF1/ YM-CL5MIDMF1/YM-CL5HLMF1/ YM-CL8W1/ YM-CL8MF1/

Appliance Commissioning Checklist	3
User Instructions	4
Getting Started	4
User Instructions	6
Care & Maintenance.....	9
Troubleshooting	12
Installation Instructions	14
Installation Checklist.....	14
Pre-Installation Instructions	19
Installing the Appliance.....	21
Commissioning	25
Maintenance & Servicing.....	27
Technical Appendix	31
Spare Parts List.....	35
Service Records	38



To receive your Extended Warranty your Yeoman appliance must have been purchased from our Expert Retailer Network and registered within one month of purchase or installation. Please note that all warranties are effective from the date of purchase. Any Yeoman product purchased outside of our Extended Retailer Network, or not registered within the stated time will carry a standard 12 month warranty.

It is a condition of the Extended Warranty that the installation complies with the relevant Building Regulations and is carried out by a suitably trained and qualified individual (HETAS in the UK or equivalent in other countries) with the certificate of installation and the Commissioning Report on Page 3 completed and retained by the end user.

Full terms and conditions are detailed in the Warranty Statement on the Yeoman website www.yeoman-stoves.co.uk. In the event of any conflict of information the wording on the website shall prevail.

Important Note: Should any problems be experienced with your product, claims must first be submitted to the Expert Retailer where the appliance was purchased from who will offer immediate assistance or contact Yeoman on your behalf.

DESIGN PROTECTION

This design is protected under Registered Community Design no's. 001202600-0004 / 001202600-0005 / 001202600-0006

Appliance Commissioning Checklist

To assist us in any guarantee claim please complete the following information:-

Retailer appliance was purchased from:

Name:

Address:

Telephone number:

Essential information - MUST be completed:

Date Installed:

Model Description:

Serial Number:

Installation Engineer:

Company Name:

Address:

Telephone number:

Commissioning Checks - to be completed and signed:

Is flue system correct for the appliance:	YES <input type="checkbox"/>	NO <input type="checkbox"/>
Flue swept and soundness test complete:	YES <input type="checkbox"/>	NO <input type="checkbox"/>
Smoke test completed on installed appliance	YES <input type="checkbox"/>	NO <input type="checkbox"/>
Spillage test completed	YES <input type="checkbox"/>	NO <input type="checkbox"/>
Use of appliance and operation of controls explained	YES <input type="checkbox"/>	NO <input type="checkbox"/>
Clearance to combustibile materials checked	YES <input type="checkbox"/>	NO <input type="checkbox"/>
Instruction book handed to customer	YES <input type="checkbox"/>	NO <input type="checkbox"/>
CO Alarm Fitted	YES <input type="checkbox"/>	NO <input type="checkbox"/>

Signature: Print Name:

Getting Started

Welcome

Congratulations on purchasing your Yeoman Stove, if installed correctly Yeoman hope it will give you many years of warmth and pleasure for which it was designed.

The purpose of this manual is to familiarise you with your stove, and give guidelines for its installation, operation and maintenance. If, after reading, you need further information, please do not hesitate to contact your Yeoman retailer.

1. General Points

- 1.1 Before installation and/or use of this appliance please read these instructions fully and carefully to ensure that you have fully understood their requirements.

The appliance must be fitted by a registered installer*, or approved by your local building control officer.

- 1.2 All local regulations, including those referring to national and European Standards need to be complied with when installing the appliance.
- 1.3 Only use for domestic heating in accordance with these operating instructions.
- 1.4 You must burn only approved fuels. Do not use with liquid fuels or as an incinerator.
- 1.5 Appliance surfaces become very hot when in use. Use a suitable fireguard[†] if young children, elderly or infirm persons are present. Yeoman offer firescreens, sparkguards and hearthgate systems for protection. Your Yeoman Retailer can advise you about these products.
- 1.6 Do not place photographs, TV's, paintings, porcelain or other combustible items on the wall or near the appliance. Exposure to hot temperatures will cause damage. Do not place furniture or other items such as drying clothing closer than 1m from the front of this appliance.

WARNING: Extra fuel should not be stored on or next to the appliance. Only keep enough fuel for immediate use nearby and never leave the appliance unattended for long periods with any combustible material in close proximity.

The exception is the CL5 Highline which has been designed with a heat shield at the bottom of the firebox to allow for the storage of wood underneath.

- 1.7 Extractor fans or cooker hoods must not be placed in the same room or space as this can cause appliance to emit fumes into the room.



†In the U.K. these products must conform to the latest edition of BS 8423, Fireguards for use with solid fuel appliances.

If appliance is operating unattended they must conform to the latest edition of BS 3248

***Registered on the Competent Persons Scheme (GB only see page 34/ INFO (Republic of Ireland).**

- 1.8 Do not obstruct inside or outside ventilation required for the safe use of this appliance.
- 1.9 Do not make unauthorised changes to the appliance.
- 1.10 The chimney must be swept at least once a year. See Section 12.
- 1.11 Do not connect, or share, the same flue or chimney system with another appliance.
- 1.12 This appliance is designed to be used with the doors shut.

SERIAL NUMBER

- 1.13 This number is required when ordering spare parts or making warranty claims. It is found on the appliance data plate.

The data plate is found on a swing out data plate located on the back of the stove on the left hand side, see Diagram 1.

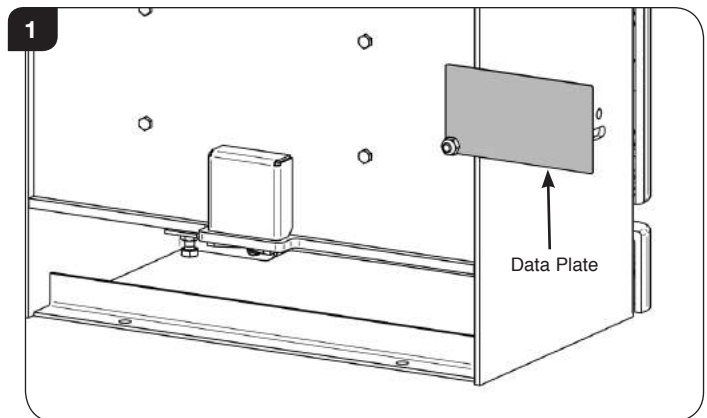

Triple Air Systems

This appliance has a triple air system providing cleaner burning, and greater efficiency and control, see Diagram 2.

- 1) **Airwash** - air drawn over the window cleans the glass. The source of Primary Combustion air when burning wood.
- 2) **Primary Air** - for use initially when establishing fires and the main air supply when burning solid fuels.
- 3) **Cleanburn** - Secondary air is preheated through a heat exchanger to combust unburned hydrocarbons, providing a cleaner and more efficient burn.

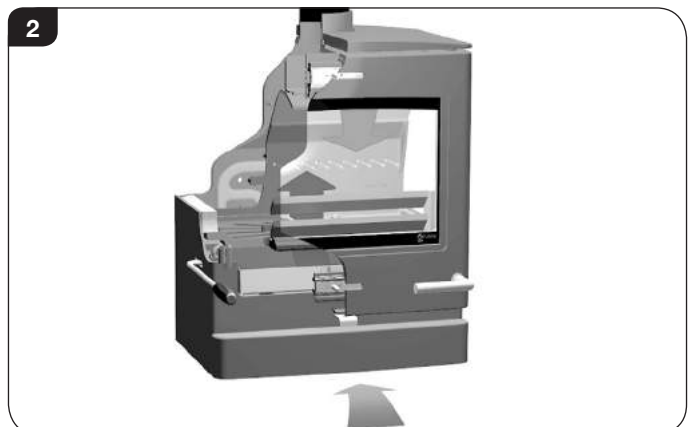

Getting Started

AIR CONTROLS

Use the tool provided to operate the air controls.

DO NOT OPERATE THE AIR CONTROLS WITH BARE HANDS

Do not place tool on hot surfaces (e.g. top of stove).

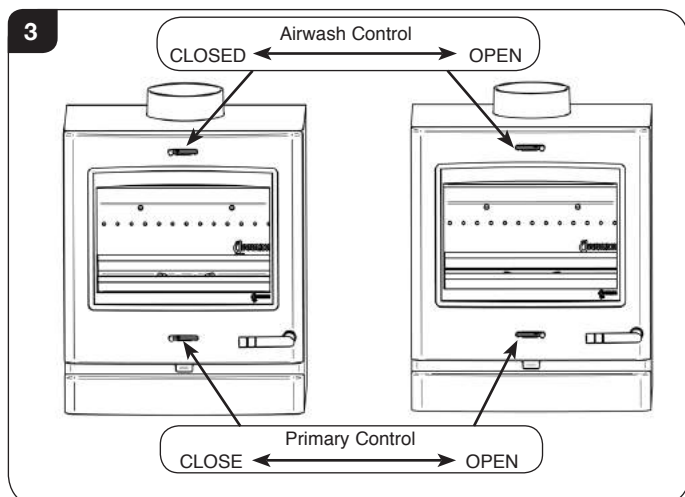

The **Secondary Air Control** is located below the appliance door, above the plinth. This control is used to adjust the amount of 'Cleanburn' combustion air injected into the burning flames. Push air control in to reduce and pull to increase the flow of air.

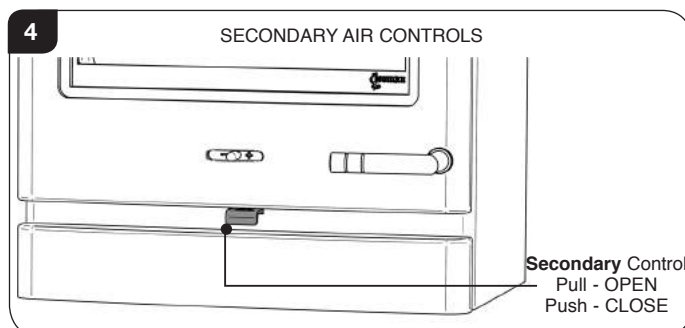

CL5 Midline & Highline - Cleanburn - Secondary Air:
The **Cleanburn** air enters the appliance through two holes in the rear. These are factory set to a nominal setting suitable for most chimneys. However these can be adjusted to suit local conditions.

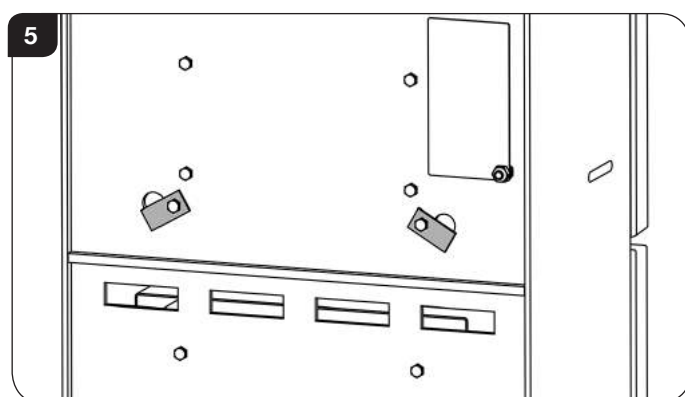

DOOR OPERATION

1.14 Use a protected gloved hand to operate.

DO NOT OPEN THE DOOR WITH BARE HANDS

DO NOT OPEN THE DOORS WHEN THE FIREBOX IS FULL OF FLAMES - WAIT FOR THEM TO DIE DOWN.

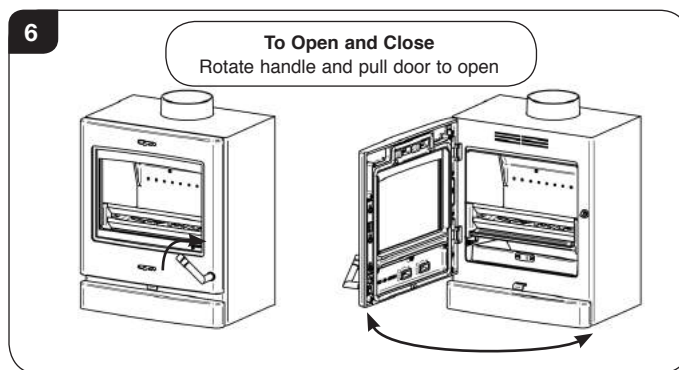

Warning: Do not force the handle as damage may occur.

WARNING



Properly installed, operated and maintained, this appliance will not emit fumes into the room. Occasional fumes from de-ashing and refuelling may occur.

Persistent fume emission is potentially dangerous and must not be tolerated.

If fume emission does persist:

- Open doors and windows to ventilate the room.
- Leave the room.
- Allow fire to burn out and safely dispose of fuel from the appliance.
- Check for chimney blockage and clean if required.
- Do not attempt to relight until the cause of the emission has been identified and corrected.
- If necessary seek expert advice.
- All open flued appliances can be affected by temporary atmospheric conditions which may allow fumes to enter the house. Because of this an electronic carbon monoxide detector conforming to the latest edition of BSEN50292 must be fitted in the same room as the appliance. The existence of an alarm must not be considered a substitute for ensuring regular servicing and maintenance of the appliance and chimney system.

IF THE ALARM SOUNDS FOLLOW THE INSTRUCTIONS GIVEN ABOVE.

Getting Started/User Instructions

2. Using the Appliance for the First Time

- 2.1 To allow the appliance to settle, and fixing glues and paint to fully cure, operate the appliance at a low temperature for first few days.
- 2.2 Do not touch the paint during the first period of use.
- 2.3 During this time the appliance may give off some unpleasant odours. Keep the room well ventilated to avoid a build-up of fumes.
- 2.4 Please be aware that, during use, rope seals may discolour. This is normal.

3. Recommended Fuels

3.1 Wood Logs:

Burn only seasoned timber with a moisture content of less than 20%. To ensure this allow cut wood to dry for 12 to 18 months.

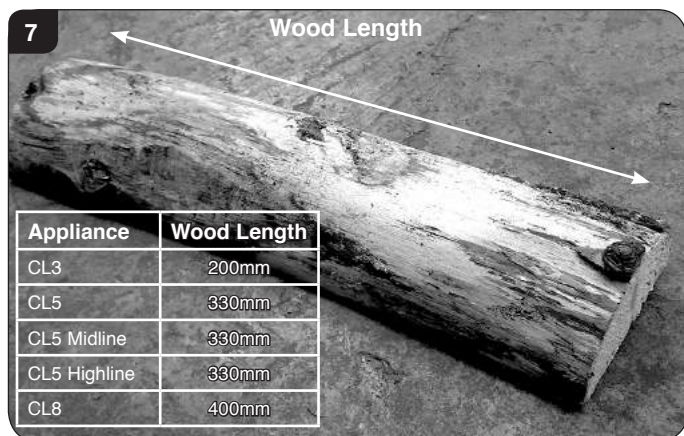

Poor quality timber:

- Causes low combustion efficiency
- Produces harmful condensation
- Reduces effectiveness of the airwash and life of the appliance

Do not burn construction timber, painted, impregnated / treated wood, manufactured board products or pallet wood.

3.2 Solid fuel:

- Burn only anthracite or manufactured briquette smokeless fuels listed as suitable for use with closed heating appliances.

Do not burn bituminous coal, 'petro-coke' or other petroleum based fuels as this will invalidate the product guarantee.

***In the U.K:**

- Ring the Solid Fuel Association advice line on 0845 601 4406 for details
- Visit their web site at www.solidfuel.co.uk

3.3 Fuel consumption.

As tested at nominal heat output to the requirements of EN 13240: 2001 for intermittent operation:

Description	Fuel Consumption	
	Kg/hour Wood	Kg/hour Briquette Smokeless fuel
CL3	1.4	0.7
CL5	1.5	0.7
CL5 Midline	1.5	0.7
CL5 Highline	1.5	0.7
CL8	2.8	1.3

HETAS Approval

Please note that HETAS Appliance Approval only covers the use of manufactured briquette smokeless fuels on these appliances. HETAS approval does not cover the use of other fuels either alone or mixed with the recommended fuels, nor does it cover instructions for the use of other fuels.

- 3.4 For advice on suitable solid fuels contact your local approved coal merchant*.

A number of factors can affect the performance of the appliance. See *Troubleshooting Section* for details.

4. Lighting the Appliance

- 4.1 Whether using wood or solid fuel the process for lighting the appliance is the same.
- 4.2 For best results set air controls, see Diagram 8.

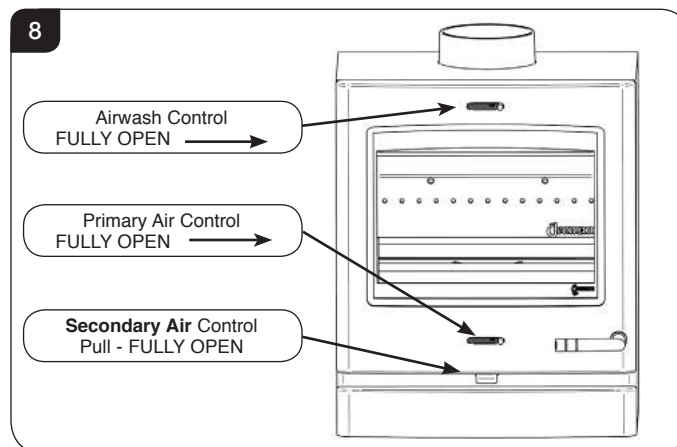

Note: The Midline and Highline do not have adjustable Secondary Air.

- 4.3 Place firelighters, or paper, and dry kindling wood on the grate (Multi-fuel version) or firebed (Woodburning version).

A successful fire initially requires plenty of kindling to establish a hot firebox and warm the chimney to aid flue performance.

User Instructions

4.4 Light the paper or firelighters, see Diagram 9.



4.5 Leave the door slightly open as the fire establishes and the glass warms to avoid build up of condensation.

4.6 Add larger pieces of wood. Do not use full sized logs at this stage, build up gradually in size. Too many logs may smother the fire.

Do not load fuel above the log guard and the Secondary Combustion Inlets at the back of the firebox, see Diagrams 10 & 11 .

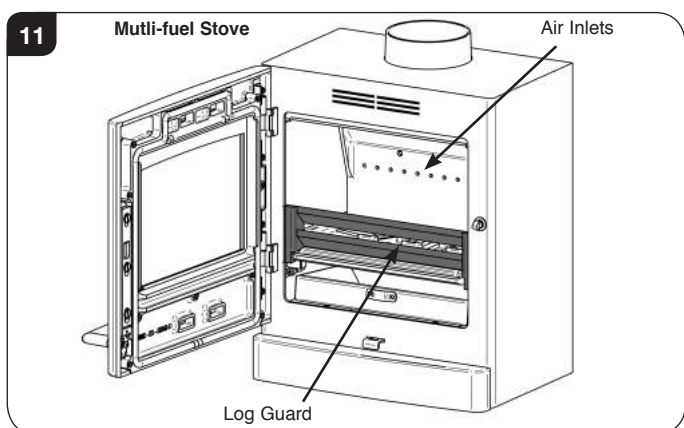
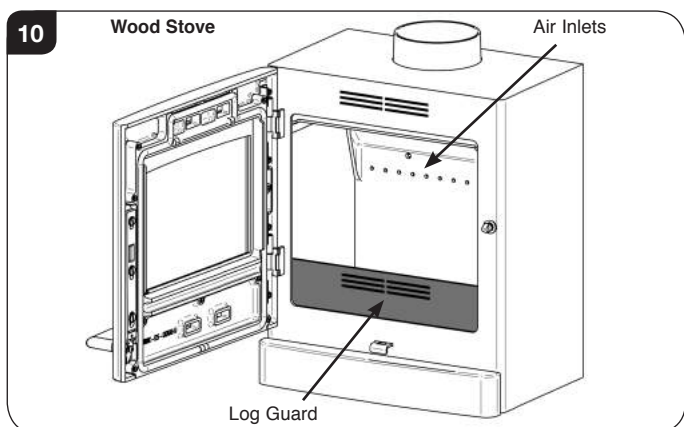

— Close the door and follow the instructions for Running the Appliance.

Do not run with the door slightly open except for initial lighting as this could cause over-firing and damage the appliance.

5. Running the Appliance

Wood Burning

5.1 Close the **Primary air control** and use the **Airwash** to control the burn rate when appliance is at operating temperature, see Diagram 12.

Adjust the Secondary Air Control to approximately 50% Open. Note: The Midline and Highline do not have adjustable Secondary Air.

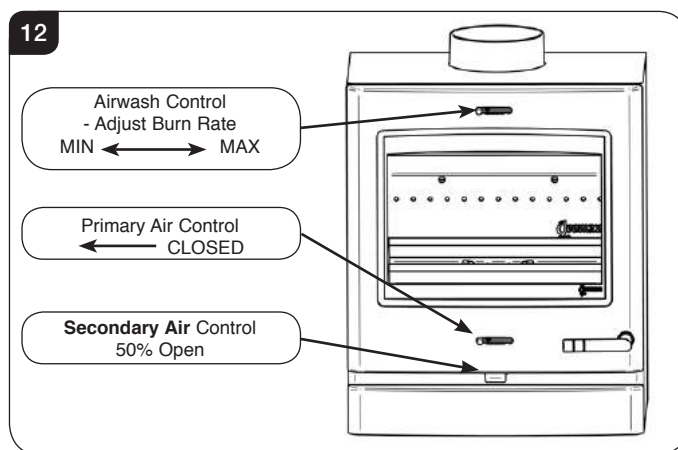

Wood burns best on a bed of ash (approx. 25mm (1") deep).

Rake the embers evenly over the firebed and open the **Airwash Control** fully for a few minutes before re-fuelling.

5.2 **Do not refuel when a large amount of flames are in the firebox as this could cause smoke or flames to spill into the room.**

5.3 **Close the doors immediately after refuelling.**

5.4 Burn new logs at a high temperature for a few minutes before adjusting the **Airwash Control**. Refuel little and often for clean, efficient burning. More Airwash will increase the heat output, burn fuel more quickly and will help keep the glass clean.

Small amounts of **Primary Air** can sometimes help to maintain a hot fuel bed.

Depending on the strength of the flue pull the **Secondary Air Control** should be adjusted so that air from the air inlets ignite unburnt smoke and flames are visible, but not so strong that flames reach the glass.

5.5 Do not burn large amounts of fuel with the **Airwash Control** closed for long periods of time. This reduces the glass cleaning effect of the Airwash and causes tars and creosotes to build-up in the appliance and flue system.

5.6 When in use, burning the appliance at a high temperature for a short period also reduces tars and creosotes. **WARNING: DO NOT OPERATE THE APPLIANCE WITH THE PRIMARY AIR CONTROL OPEN OR AIRWASH ON MAXIMUM FOR LONG PERIODS OF TIME AS THIS COULD CAUSE OVER-FIRING AND MAY CAUSE PERMANENT DAMAGE.**

5.7 Experience establishes settings to suit personal preference.

User Instructions

Smoke Control version

- 5.8 Some appliances have been independently tested to PD6434 and have been exempt from the controls that generally apply in smoke control areas hence are considered suitable for use in Smoke Control Area when burning wood and **ONLY** when fitted with the relevant Smoke Control kit.
See Section 15 - Optional Extras.
Contact your retailer for more information.

Burning Solid Fuel

- 5.9 **Solid Fuel can only be burned in a multi-fuel stove.**
- Only for use with recommended fuels, (see User Instructions, Section 3).**
- 5.10 Allow the fire to become established before adding the solid fuel, see section 4.
- Set air controls, see Diagram 13.

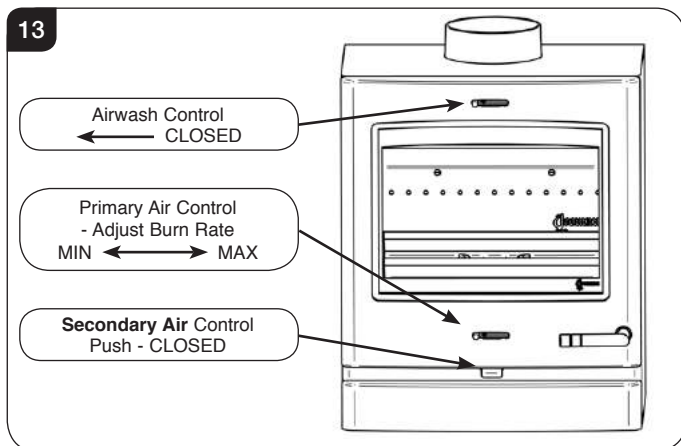

- 5.11 To burn solid fuel efficiently it is best to control the burn rate using the **Primary air control** only.
- 5.12 De-ash the grate before re-fuelling (see *User Instructions, Section 7*).
- Open the **Primary Air Control** fully to establish a glowing bed before adding new fuel.
- 5.13 Add the correct amount of fuel, see Section 3.
- 5.14 **Close the doors immediately after refuelling.**
- Burn new fuel at a high temperature for a few minutes before adjusting the **Primary Air Control** to the desired setting.
- Refuel little and often for clean, efficient burning.
- When burning solid fuel more primary air will increase the heat output and burn the fuel more quickly.
- A small amount of Airwash can sometimes help to keep the glass clean but will reduce efficiency.
- Always have the **Secondary Air Control** shut when burning solid fuel to ensure the maximum efficiency from the appliance.

- 5.15 Experience establishes settings to suit personal preference.
- 5.16 Do not burn large amounts of fuel with the **Primary Air Control** on a low combustion setting for long periods of time. This reduces the glass cleaning effect of the Airwash and causes tars and creosotes to build-up in the appliance and flue system.
- 5.17 When in use, burning the appliance at a high temperature for a short period reduces tars and creosotes.
WARNING: DO NOT OPERATE THE APPLIANCE WITH THE PRIMARY AIR CONTROL OPEN OR AIRWASH ON MAXIMUM FOR LONG PERIODS OF TIME AS THIS COULD CAUSE OVER-FIRING AND MAY CAUSE PERMANENT DAMAGE.
- 5.18 **Only anthracite or smokeless fuels suitable for use in closed appliances must be burned in this appliance.**
- 5.19 **Do not burn bituminous coal, 'petro-coke' or other petroleum based fuels as this invalidates the product guarantee.**
- 5.20 **Do not load fuel above the log guard and the Secondary Air Inlets at the back of the firebox, see Diagrams 10 or 11.**

Shut Down

- 5.21 If there is still burning fuel in the firebox, Yeoman do not recommend shutting down the air controls completely unless there is a chimney fire in progress (see section 9 for advice). Closing the controls during the burning process will cause poor combustion and could lead to a build up of gasses that could ignite dangerously.
- 5.22 Always have enough air entering the stove to maintain some flame within the firebox.
- 5.23 If it is necessary to shut down the appliance then run on a high setting until all of the fuel has been burnt before closing the air controls.

6. Extended Burning

- 6.1 It is possible to get the appliance to burn for extended periods of time. In order to do this:
- De-ash prior to final refuelling.
 - Burn new fuel at a high temperature for a few minutes before adjusting the **Primary Air Control**.
 - Set air controls to low combustion settings. This will gradually blacken the glass but it will clear when operated at a high temperature for a short period.

User Instructions/Care & Maintenance

7. Ash Removal

Do not allow ash to build up as it may cause damage and adversely effect the performance of the appliance. Warning: Ash can remain hot long after appliance has been in use.

7.1 Wood versions only.

- Open Door.
- Leave a layer of ash to start the new fire on. Wood burns best on a bed of ash (approx. 25mm (1") deep).
- Remove ash with a small shovel and place into an Ash Caddy (Part No. 4227) or other suitable container.

Do not place hot ash in any container made from plastic or any other combustible material.

- De-ash at least once a week.

7.2 Multi-fuel Versions

De-ash the appliance before filling with new fuel. Do not allow ash to build up on the underside of the grate as this can cause premature failure.

- Riddle with the tool provided, see Diagram 14.

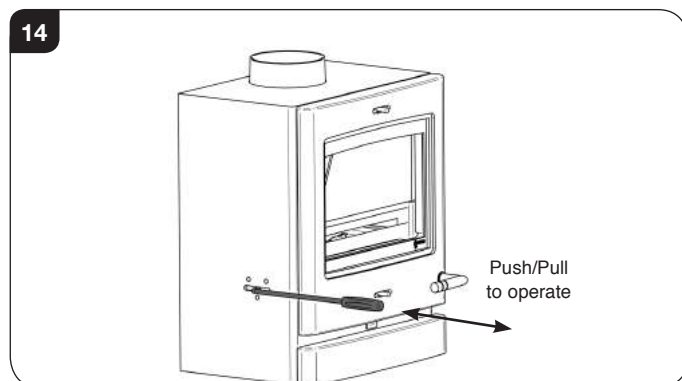

- Move the Riddling Tool backward and forward 3 or 4 times to remove the ash. Do not force the handle beyond its natural stop point. The ash will fall into the ashpan.

7.3 Open the door.

Warning: Ash can remain hot long after appliance has been in use.

Using gloves, carefully remove ashpan using tool supplied, see Diagram 15. Ensure the tool is fully engaged before operation. Practise this technique before hand with a cold ashpan.

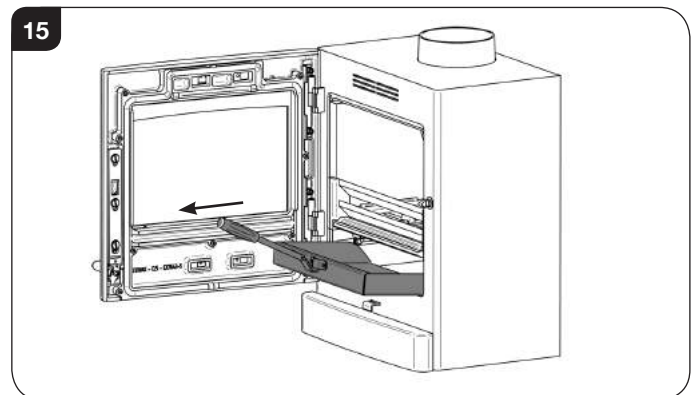

- 7.4 Place the ash into a Ash Caddy (Part No. 4227) or other suitable container.
- 7.5 Check and remove ash as often as required when burning solid fuel.
- 7.6 De- ash at least once a week.

Do not place hot ash in a container made from plastic or any other combustible material.

8. Over-Firing

- 8.1 Do not over-fill with fuel or run at high temperatures for long periods or over-firing can occur.
WARNING: DO NOT OPERATE THE APPLIANCE WITH THE PRIMARY AIR CONTROL OPEN OR AIRWASH ON MAXIMUM FOR LONG PERIODS OF TIME AS THIS COULD CAUSE OVER-FIRING AND MAY CAUSE PERMANENT DAMAGE.
- 8.2 **Over-firing can cause permanent damage to the appliance and invalid the product warranty.**

Care & Maintenance

9. Chimney Fire

- 9.1 **If a chimney fire occurs:**
- Shut all air controls immediately.
 - Evacuate the building.
 - Call the fire brigade.
 - Do not re-enter the building until it is confirmed safe.
- 9.2 **Do not use the appliance after a chimney fire until:**
- a) It has been inspected by a registered installer*, confirming the appliance is safe to use.
- b) The chimney system has been inspected and swept by a chimney sweep, confirming the system is structurally sound and free from obstruction*.
- c) It is repaired as required before re-use. Use only genuine Yeoman replacement parts to keep your appliance in safe, efficient working order.

10. General Cleaning

- 10.1 Clean and inspect the appliance regularly, especially in periods of heavy use. Regular cleaning and maintenance will help give many years of safe use.
- 10.2 **Allow appliance to cool thoroughly to avoid risk of burns.**
- 10.3 Clean regularly, according to level of use.
- Remove the ash completely.
(See *User Instructions, Section 7*).
- 10.4 Check internal components for damage - grate, bricks, baffles, log guard - and for obvious build up of soot, ash or debris above the flue baffle(s) (these can be found in the upper part of the firebox). Use a torch if necessary.
- 10.5 If there are any signs of a build up of debris above the flue baffle(s) either:
- Arrange for the chimney to be swept (see *Care & Maintenance Instructions, Section 12*).
 - Remove the baffles and clear the debris (see *Pre-Installation Instructions, Section 3*).
- 10.6 To refresh painted finishes a touch up spray is available. Contact your Yeoman retailer quoting the serial number found on the appliance data badge.
- Do not use aerosol sprays near an operating appliance. Do not use abrasive cleaner or cleaning pads.**
- 10.7 Check that the door shuts properly and creates an effective seal. Leaking door seals prevent the appliance working properly.



*Registered on the Competent Persons Scheme (GB only) see page 34/ INFO (Republic of Ireland).

11. Cleaning Glass

- 11.1 Keep the glass clean with correct use of the Airwash system and good quality fuel.
- 11.2 Sometimes additional cleaning may be required. Before undertaking this operation allow appliance to cool fully. Do not clean hot glass.
- 11.3 **On appliances with printed glass do not use cleaning agents that have a high alkaline or acidic content, for example Stovax Gel Cleaner, these are aggressive cleaning agents designed to be used with heavily stained clear glass. On printed glass surfaces, use Stovax Glass Cleaner (Stovax No.4103) which is better formulated for this application.**
- 11.4 Before applying a cleaning agent remove any dust and loose soot with a damp cloth.
- 11.5 Use an appropriate glass cleaner. Apply the cleaning fluid to a cloth before rubbing onto the glass. Apply carefully and do not apply excessively. Try to prevent any run off which could soak into the rope seals around the edge of the glass. Soot can also contain acidic particles that can cause corrosive damage to printed glass.
- 11.6 Remove dirt with a moist cloth and buff dry.
- 11.7 **Some types of wood and solid fuel can cause a white residue to form on the glass. If this occurs it should be cleaned off at least once a week during periods of heavy usage. If the liquid cleaning agents recommended do not remove this residue use a dry cleaning pad which will help remove these white marks.**
- 11.8 Before relighting the appliance ensure the glass is fully dried. If the rope seal has absorbed excess cleaning agent it is advisable to replace the rope as soon as possible to preserve the printed finish of the glass.

12. Chimney Sweeping

- 12.1 To maintain safe and efficient use of the appliance, the chimney/flue must be inspected and swept at least once a year by a qualified chimney sweep*.
- If the appliance is used continuously throughout the year, or it is used to burn wood, more frequent sweeping is recommended.
- The best time to have the chimney swept is at the start of the heating season.
- 12.2 The chimney, any connecting flue pipe and the appliance flue ways, if incorporated, must be regularly cleaned.
- 12.3 Ensure adequate access for cleaning where it is not possible to sweep through the chimney.
- 12.4 If the chimney is believed to have previously served an open fire it must be swept a second time within a month of regular use after installation.

Care & Maintenance

13. Care Of Stove

Yeoman has a range of cleaning and maintenance products and accessories to keep your appliance in good working order. Your Yeoman retailer can advise you on suitable items for your stove and provide genuine spare parts such as replacement glass, door sealing rope and firebricks. View the extensive range at www.yeomanstoves.co.uk by clicking on *Accessories*. In addition, an annual service by a competent engineer is recommended to keep your stove in the best possible condition.



14. Seasonal Use

- 14.1 Clean and service the appliance if not used during the warmer months, as detailed in the *Maintenance and Servicing* section.
- 14.2 Set the air controls to 50% to keep the appliance ventilated and stop the build-up of any moisture inside.
- 14.3 Before re-lighting the appliance:
 - Remove the baffles.
 - Clear any debris that may have accumulated.
 - Check the flue is clear of any blockages.

15. Optional Extras

Smoke Control Kit

- 15.1 This appliance can be modified to burn wood in a smoke control zone. For more details on the Smoke Control Kit for this appliance contact your retailer.

NOTE: These appliances have been independently tested to PD6434 and have been exempt from the controls that generally apply in smoke control areas hence are considered suitable for use in Smoke Control Area when burning wood and ONLY when fitted with the relevant Smoke Control kit.

Product Code	Appliance	Smoke Control Kit Part No.
YM-CL3MF1	Yeoman CL3 MF	YM-CL3SCKIT
YM-CL5MF1	Yeoman CL5 MF	YM-CL5MFSCKIT
YM-CL5HLMF1	Yeoman CL5 Highline MF	YM-CL5MFSCKIT
YM-CL5MIDMF1	Yeoman CL5 Midline MF	YM-CL5MFSCKIT
YM-CL5W1	Yeoman CL5 Wood	YM-CL5SCKIT

Heat Shield (CL3 & CL5 only)

- 15.2 This appliance can be fitted with a heat shield in order to decrease the distance the appliance can be installed from a wall. This must be done at the time of installation. Please refer to instructions.

Appliance	Part No.
CL3	YM-CL3-HSK
CL5/ CL5 Midline/ CL6 Highline	YM-CL5-HSK

Troubleshooting

Troubleshooting

	Symptom	Cause	Solution
OPERATION	Difficulty starting the fire and keeping it burning well	Low flue draught	Consult your installer
		Wet wood (over 20% moisture)	Use dry seasoned wood (less than 20% moisture content)
	Poor burning control	High flue draught	Consult your installer
	Short burn times	Wet wood (over 20% moisture) Insufficient amount of fuel - Refer to the table in section 3	Use dry seasoned wood (less than 20% moisture content)
	Excessive heat output (Over firing)	High flue draught	Consult your installer
		Air control left fully open	Close air control to reduce output
	Low heat output	Low flue draught	Consult your installer for advice on suitable flue system
		Wet wood (over 20% moisture)	Use dry seasoned wood (less than 20% moisture content)
Excessive fuel consumption	High flue draught	Consult your installer for advice on suitable flue system	
	Over dry wood	Do not use constructional timber or pallet wood	
SMOKE EMISSIONS	Smoke and small flames	Wet wood (over 20% moisture)	Use dry seasoned wood (less than 20% moisture content)
	Intermittent smoke spillage into room when appliance door is opened	Low flue draught	Consult your installer for advice on suitable flue system
		Incorrect additional ventilation air in to building	Consult your installer
	Continuous smoke spillage into room when appliance in use	Blocked flue	Open all doors and windows to ventilate the room. Allow the fire to burn out. Check flue for blockage. Do not re-use until cause of spillage is identified. Consult your installer for advice
Blue/grey smoke from chimney	Wet wood (over 20% moisture)	Use dry seasoned wood (less than 20% moisture content)	
ADVERSE WEATHER	Windy days, intermittent smoke spillage into room when appliance door is opened	Down draught in flue caused by air turbulence caused by nearby buildings or trees	Weather conditions combined with the flue terminal position can have an effect on the appliance performance. Consult your installer
	Calm days, intermittent smoke spillage into room when appliance door is opened	Over size flue giving poor flue draught	Weather conditions combined with the flue terminal position can have an effect on the appliance performance. Consult your installer
	Damp/Rainy days lighting and burning problems	Flue temperature low / rain water inside flue	Use good quality wood to start and maintain the fire, consult your installer to fit a rain cowl
	Wind noise from the air control	High flue draught	Consult your installer for advice on suitable flue system

Troubleshooting

	Symptom	Cause	Solution
THE APPLIANCE	Rapid creosote build-up in the chimney	Wet wood (over 20% moisture)	Use dry seasoned wood (less than 20% moisture content). Operate at a high temperature for short periods each time the appliance is used to avoid large build-ups of tars and creosotes
	Tar coming from flue joints	Appliance operated at continuous low temperatures	Operate at a high temperature for short periods each time the appliance is used to avoid large build-ups of tars and creosotes. See user instructions for correct use of air control
		Using poor quality wood	Use dry seasoned wood (less than 20% moisture content)
	Strong pungent smell after the appliance is lit	Appliance operated at continuous low output	Operate at high output for short periods. See user instructions for correct use of air control
		Using poor quality wood	Use dry seasoned wood (less than 20% moisture content)
	Wind noise from the air control	High flue draught	Consult your installer for advice on suitable flue system
	Dirty firebricks	Wet wood (over 20% moisture)	Use dry seasoned wood (less than 20% moisture content)
	Dirty glass	Wet wood (over 20% moisture)	Use dry seasoned wood (less than 20% moisture content)
	Glass blackening	Using poor quality wood	Use dry seasoned wood (less than 20% moisture content)
		Low flue draught	Consult your installer for advice on suitable flue system
Incorrect use of air control		See user instructions for correct use of air control	
Appliance operated at continuous low temperatures		Operate at high output for short periods. See user instructions for correct use of air control	

FLUES	The flue system has two main functions:
	<ul style="list-style-type: none"> - To safely remove the smoke, fumes and combustion gases from the building. - To provide a sufficient amount of flue draught (suction) in the appliance to ensure the fire keeps burning.
	The flue draught is caused by rising hot gases when the appliance is lit.
	Tar and creosote are a major cause of chimney fires. If the appliance experiences problems with tar build up consult a chimney sweep before continued use of the appliance.
	For advise on the correction of persistent flue problems consult a qualified heating engineer before continuing to use the appliance.

Installation Checklist

Please Note

This section is intended to give an overview of the product performance and essential information required for installing the appliance. It is intended for qualified engineers who are already familiar with Yeoman products.

For full details and expanded information please see the Technical Appendix at the back of this manual.

1. Yeoman Dimensions

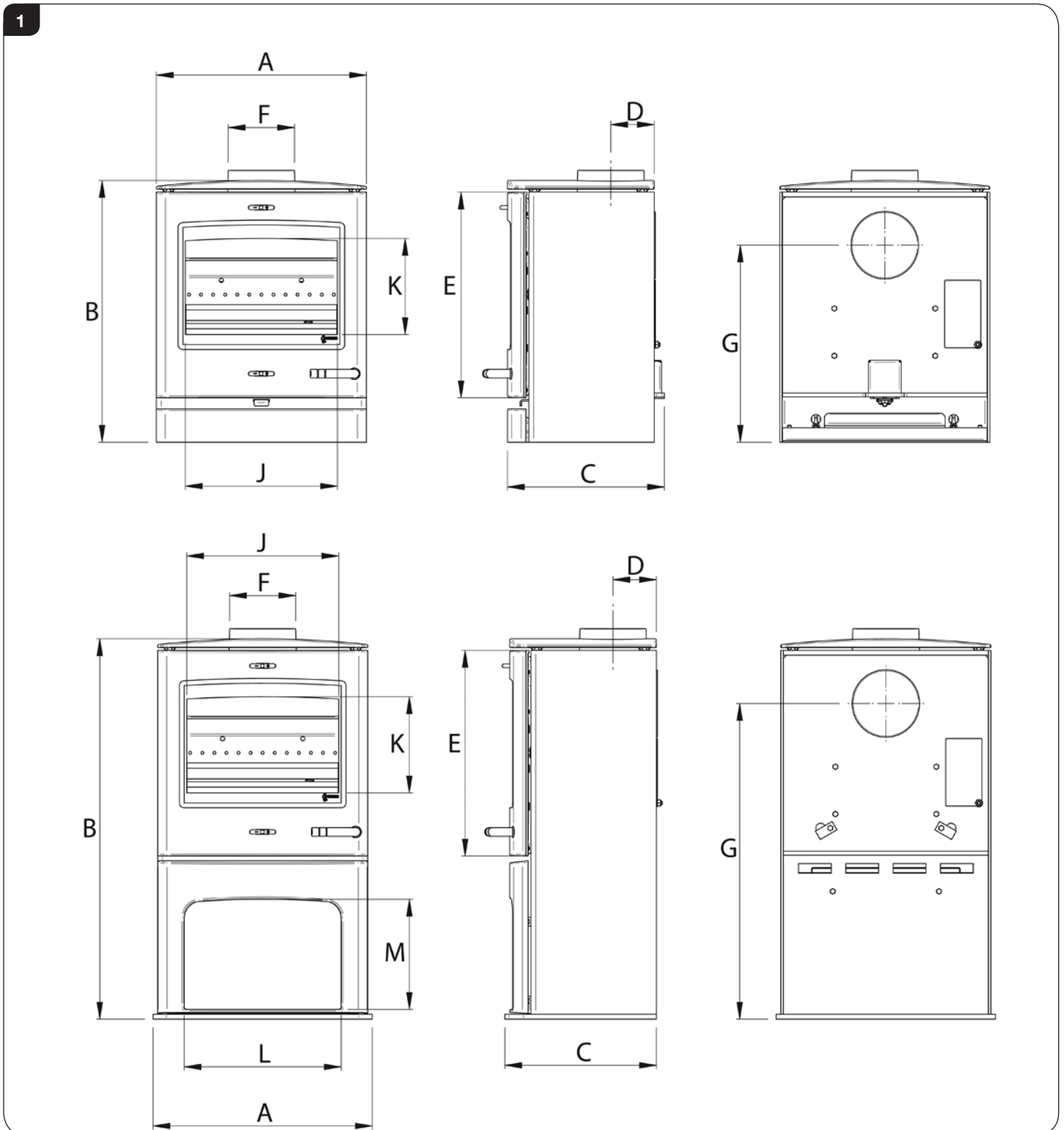

Installation Checklist

Dimensions Continued.

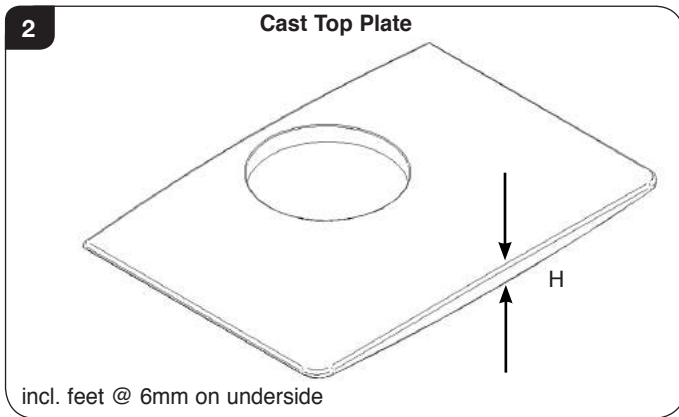

Description	Model	A	B	C	D	E	F (Ø)	G	H	J	K	L	M
CL3	YM-CL3MF1	360	532	328	93	416	128/5"	400	22	240	195	-	-
CL5	YM-CL5W1	435	542	325	90	426	128/5"	408	24	315	199	-	-
	YM-CL5MF1												
CL5 Midline	YM-CL5MIDMF1	454	787.5	314	90	426	128/5"	653.5	24	315	199	325	224
CL5 Highline	YM-CL5HLMF1	454	897.5	314	90	426	128/5"	763.5	24	315	199	325	333
CL8	YM-CL8W1	563	596	385	105	478	153/6"	449	24	441	245	-	-
	YM-CL8MF1												

All dimensions in mm. (25.4 mm = 1")

i In the U.K. Additional information covering the installation of the appliance may be found in the following British Standards: BS EN 15287, BS6999, BS8303.

Installation Checklist

Please Note

GENERAL	Model:		CL3	CL5	CL5 Midline	CL5 Highline	CL8
	CL3 - CL5 CL5 Midline CL5 Highline CL8						
Nominal Heat Output	Wood	kW	3.75	4.9	4.9	4.9	8
	Solid Fuel	kW	3.75	4.9	4.9	4.9	8.6
Efficiency	Wood	%	77	80	80	80	76
	Solid Fuel	%	86	85	85	85	81
CO @ 13% O ₂	Wood	%	0.27	0.22	0.22	0.22	0.08
	Solid Fuel	%	0.20	0.29	0.29	0.29	0.25
Weight		Kg	71	81	109	116	119
Recommended Fuels	Wood	Seasoned Wood (less than 20% moisture content)					
	Solid Fuel	Briquette smokeless fuel suitable for closed appliances (Ancit-Phuracite-Taybrite-Homefire Ovals)					

As tested to the requirements of EN 13240 for intermittent operation

FLUES	Flue/Chimney Size	Without flue liner Round (Diameter)	mm	128	128	128	128	153
			inch	5	5	5	5	6
		Without flue liner system (Square)	mm	135	135	135	135	135
			inch	5½	5½	5½	5½	5½
		With Liner of Factory made system (diameter) installed in accordance with manufacturers instructions	mm	150	150	150	150	150
			inch	6	6	6	6	6
Flue/Chimney minimum height**	All products **must be 4.5m from the hearth to the top of the flue, with no horizontal sections and a maximum of 4 bends. Bends must have angles of less than 45 degrees from the vertical.	m	4.5	4.5	4.5	4.5	4.5	
		feet	15	15	15	15	15	
Flue Draught	Min	mm Wg	1.0	1.0	1.0	1.0	1.0	
	Nominal		1.25	1.25	1.25	1.25	1.25	
	Max		2.0	2.0	2.0	2.0	2.0	
Flue Gas Mass Flow	Wood	g/s	3.8	2.6	2.6	2.6	7.0	
	Solid Fuel	g/s	2.9	3.2	3.2	3.2	7.3	
Flue Gas Temperature at Spigot/Socket	Wood	°C	408	369	369	369	446	
	Solid Fuel	°C	408	369	369	369	446	
Flue Outlet Size (Top or Rear Option)	All	mm	128	128	128	128	153	
		inch	5	5	5	5	6	

European Min Spec for Chimney Flue - T400 N2 D 3 G50

VENTILATION	A) Traditionally Built Homes		B) Modern Construction Homes					
	• Where leakage is greater than 5m ³ /hour/m ² .		• Where leakage is less than 5m ³ /hour/m ² .					
	• Ventilation normally required = 550mm ² per kW output over 5kW		• Ventilation normally required = 550mm ² per kW					
	A	Additional Ventilation	mm ²	None	None	None	None	1650
			cm ²	None	None	None	None	16.5
			in ²	None	None	None	None	2.6
B	Additional Ventilation	mm ²	2062	2695	2695	2695	4400	
		cm ²	20.6	26.9	26.9	26.9	44	
		in ²	3.3	4.3	4.3	4.3	7.1	

For full technical details on ventilation see Technical Appendix on Page 33

Installation Checklist

3. Minimum Dimensions - Hearth

3.1 Hearth construction must comply with the building regulations in force. The appliance must stand on a non-combustible constructional hearth which is at least 125mm thick with the minimum dimensions as shown in Diagram 3.

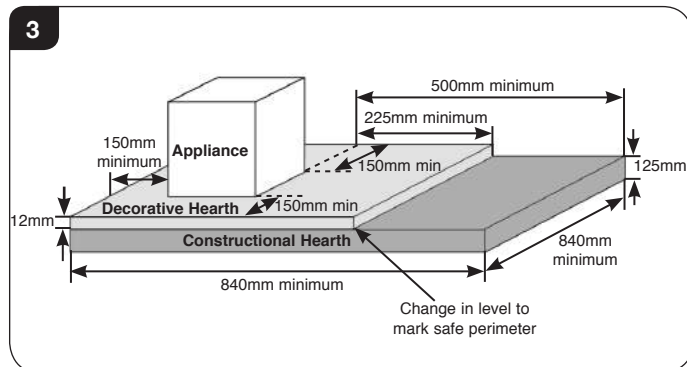

Some appliances like the CL Midline & Highline range do not raise the floor temperature enough to require a constructional hearth. These appliances can stand on a superficial hearth which is a minimum of 12mm thick, see Diagram 4. This is also referred to as a Floor Protector Plate or Floor Protector.

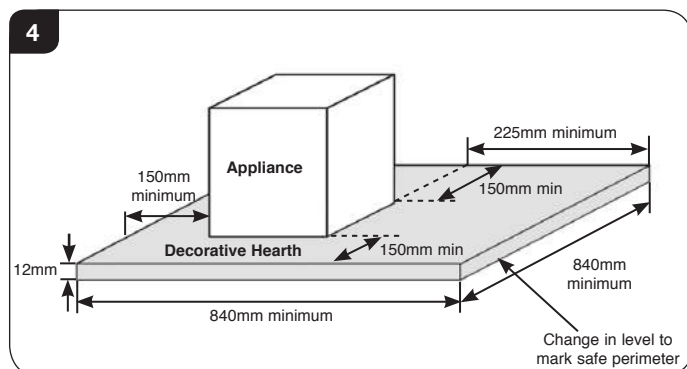

3.2 If this appliance is installed in an elevated setting (Midline & Highline) it is recommended to increase the 225mm hearth depth to safely contain any falling logs or embers. The higher the appliance is installed the deeper the hearth should be to avoid scorched floor coverings.

i † England and Wales – Document J / Scotland - Part F/Document J (Republic of Ireland only)

4. Clearances



IMPORTANT: INSTALLATION MUST COMPLY WITH CURRENT BUILDING REGULATIONS

ENSURE THAT SUFFICIENT CLEARANCES ARE PROVIDED BETWEEN THE FLUE PIPE AND ANY COMBUSTIBLE MATERIALS IN THE FIREPLACE IN ACCORDANCE WITH THE RULES IN FORCE. †

4.1 When installing a Yeoman CL stove it is important to observe the following clearances to both **combustible** and **non-combustible** materials. Also ensure that a clearance of 1 metre is maintained in front of the appliance when operating.

Fireplace: Minimum Clearances Above & to the Sides

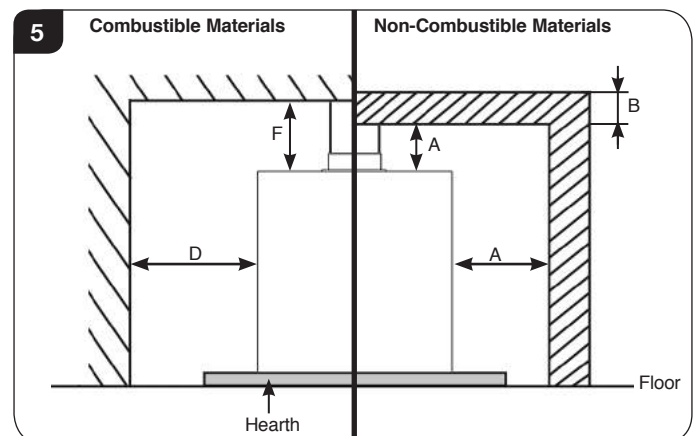

Fireplace: Minimum Clearances to the Rear

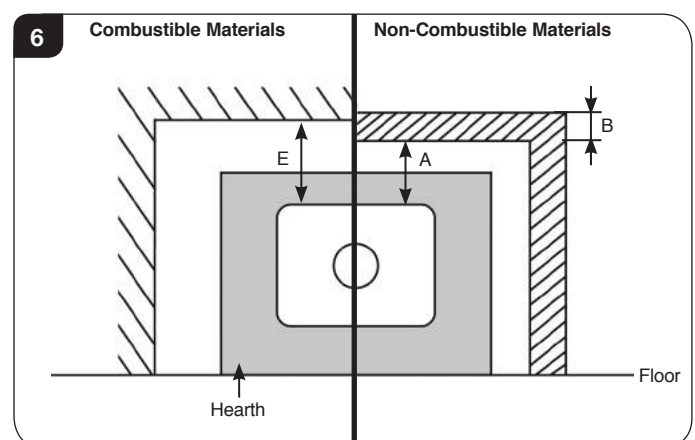

Leave enough space to attach the product to the floor. If these dimensions are reduced an alternative method of fixing must be used other than the support bracket.

Installation Checklist

Non-Combustible Materials

- 4.2 All appliances will require some clearance between them and any non-combustible materials to allow for either:
- Installation, servicing or accessing controls.
 - Convection in order for the appliance to function properly.

Minimum clearances for installation/servicing/convection is:

Rear - 75mm	Sides - 75mm	Top - 100mm
-------------	--------------	-------------

NOTE: If the non-combustible surface is less than 200mm thick additional clearances may be required. This requirement ensures that the non-combustible material does not transmit excessive heat through the wall onto combustible material which might be placed against it.

See Diagrams 5 & 6 (Fireplaces) & Diagram 7 (Freestanding) and table below.

Distance to Non-combustible Materials		
Distance of Appliance to Wall (A)	Minimum Thickness of wall (B)	Minimum Height of Wall (C)
0mm - 50mm*	200mm	Height of appliance + 300mm OR 1200mm from the hearth (take largest dimension)
51mm - 300mm	75mm	
300mm+	No requirement	No requirement

Freestanding Installation

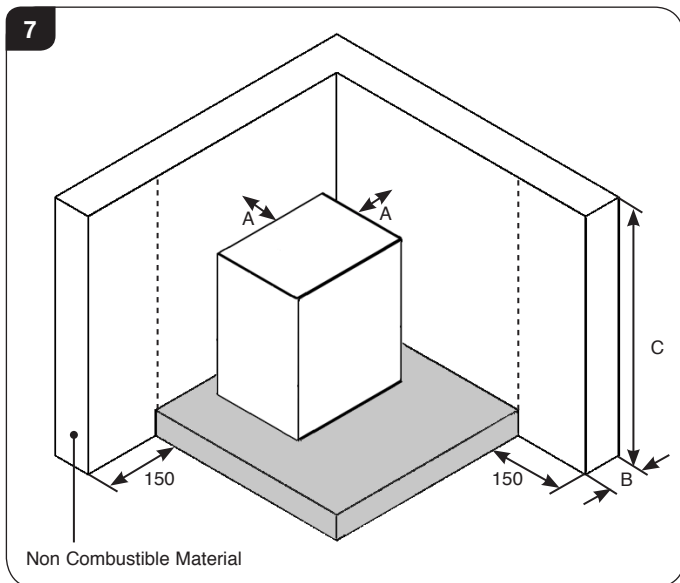

Combustible Materials

- 4.3 It is essential for safety to ensure the following clearances to combustible materials are maintained.

See Diagrams 5 & 6 and table below.

Model	D (side)	E (Rear)*	F (Above)
CL3	300	500	N/A
CL5	300	700	N/A
CL5 Midline	300	300	N/A
CL5 Highline	300	300	N/A
CL8	350	350	N/A

* Note this distance can be reduced by the fitting of a heat shield kit, check with your Yeoman retailer for availability and clearances.

5. Optional Extras

Smoke Control Kit

- 5.1 Some appliances can be modified to burn wood in a smoke control zone. For more details on the Smoke Control Kit for this appliance contact your retailer.

NOTE: These appliances have been independently tested to PD6434 and have been exempt from the controls that generally apply in smoke control areas hence are considered suitable for use in Smoke Control Area when burning wood and **ONLY** when fitted with the relevant Smoke Control kit.

See User Section 15 - *Optional Extras*.

Heat Shield (CL3 & CL5 only)

- 5.2 This appliance can be fitted with a heat shield in order to decrease the distance the appliance can be installed from a wall. This must be done at the time of installation. Please refer to instructions.

Pre-Installation Instructions

1. General

- 1.1 To make the installation of the appliance easier it is best to remove the internal components before fitting into the builders opening/studwork.

PACKING LIST

All Models:

- User & Installer Instructions
- Guarantee card
- Pair leather gloves
- Fire bricks

CL3, CL5 & CL8 only:

- 2 x L shaped brackets for alternative hearth fixing

Wood:

- Secondary Air tool

Multi Fuel:

- Ashpan
- Ashpan/Secondary Air tool
- Riddling tool

STANDARD FEATURES

All Models:

- Primary Air (under grate air for full multi-fuel use)
- Airwash (for wood burning / clean glass)
- Adjustable Secondary Air control to ensure complete burning of flue gases (Not Midline/Highline these are preset)
- Top or rear flue exit option

Multi Fuel:

- Riddling grate system for clean de-ashing

- 1.2 For the best results removing the following components as set out below.

2. Removal of the Log Guard

- 2.1 To remove the Log guard:
- Lift Log Guard clear of the supporting brackets.
 - Rotate to clear the sides of the door opening.

When refitting the log guard ensure it is positioned correctly with the casting stamps facing the back of the appliance or it may damage the glass on shutting the door.

Do not use appliance without the log guard in position.

3. Removal of the Baffles

- 3.1 The appliance is fitted with a baffle in the top of the firebox to maintain efficient combustion.
- 3.2 Allow the stove to cool fully before removing the baffle system.
- 3.3 To remove the baffle:

Remove the log guard for access.

Lift the front edge of the baffle to clear the support bars and pull forward to disengage the rear edge from the location above air inlet holes.

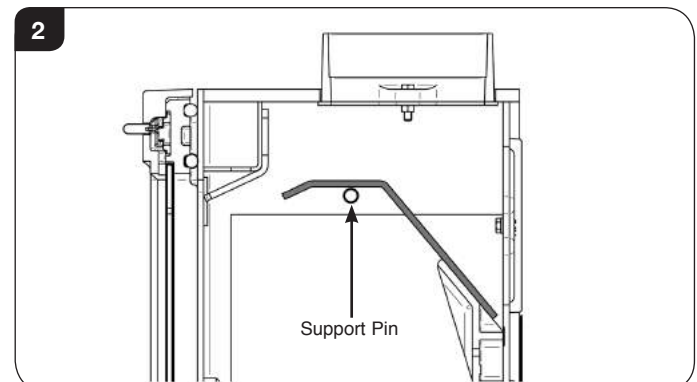
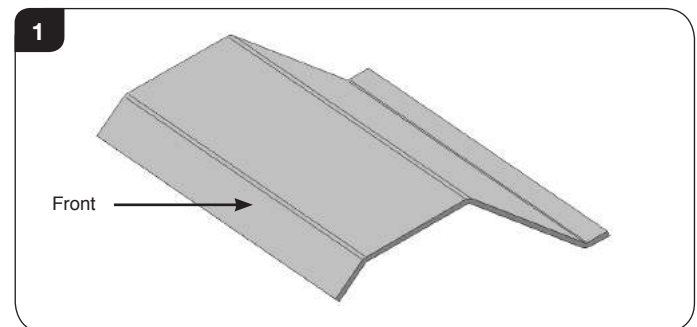

- 3.4 Rotate the baffle to remove from the firebox through the door opening.
- 3.5 Replace in reverse order.
- 3.6 Remove and clean the baffle system to ensure the flue ways are clear of soot and debris and to ensure the safe, efficient operation of the stove. The frequency of cleaning will depend on the stove operating conditions.
- 3.7 The baffle system is designed to give safe and efficient operation of the stove. Replace any damaged baffles immediately.
- 3.8 Do not modify the baffle system.

Pre-Installation Instructions

4. Removal of the Fire Bricks

- 4.1 Remove the firebricks as part of the routine maintenance. This can be carried out without the use of tools.
- 4.2 Allow the appliance to cool fully before removing firebricks.
- 4.3 Take care when handling, as bricks can become fragile after use. Life span depends on the type of fuels burnt and the level of use.

Replace damaged bricks as soon as possible.

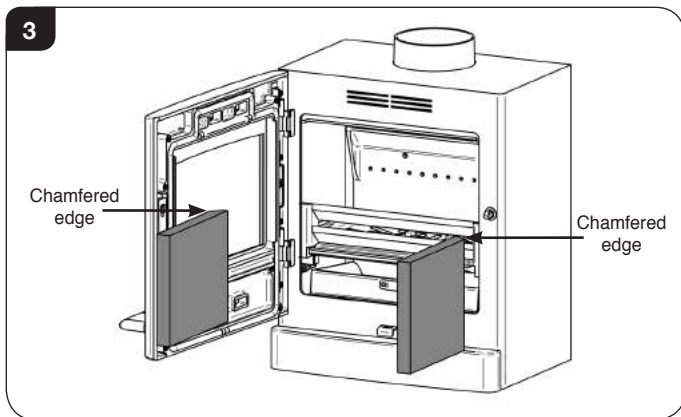

Replace in the same orientation.

5. Removal of the Cast Plinth

- 5.1 The Cast Plinth can be removed to aid in the installation or as part of the routine maintenance. This can be carried out without the use of tools.
- 5.2 The Cast Plinth locates on the carcass and is held in place by two keyhole slots, see Diagram 4.

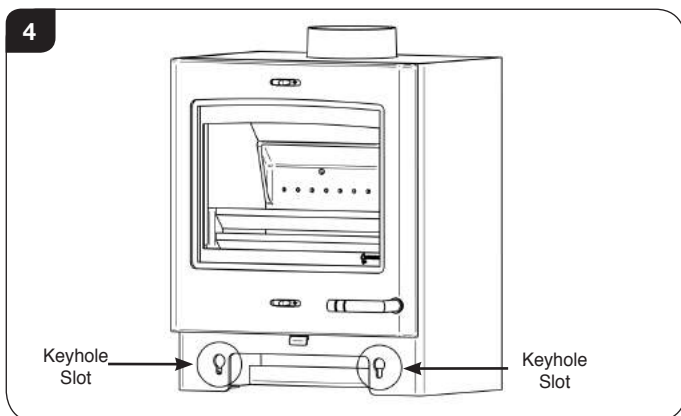

- 5.3 Before removing the Cast Plinth, push the Secondary Air control (situated above the plinth and below the door) back against the carcass, see Diagram 5.

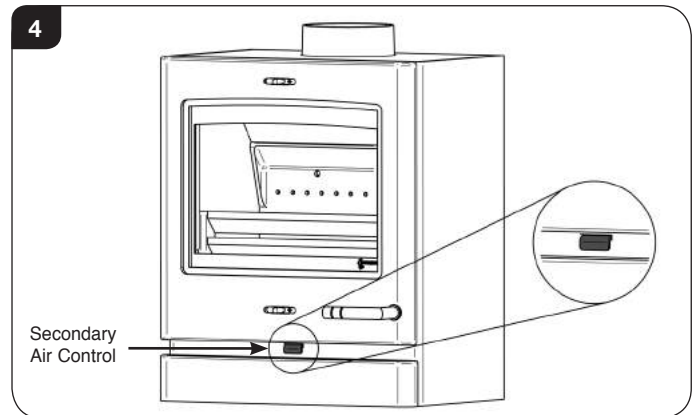

- 5.4 Lift the Cast Plinth within the keyhole slot to the larger cutout, see Diagram 6.

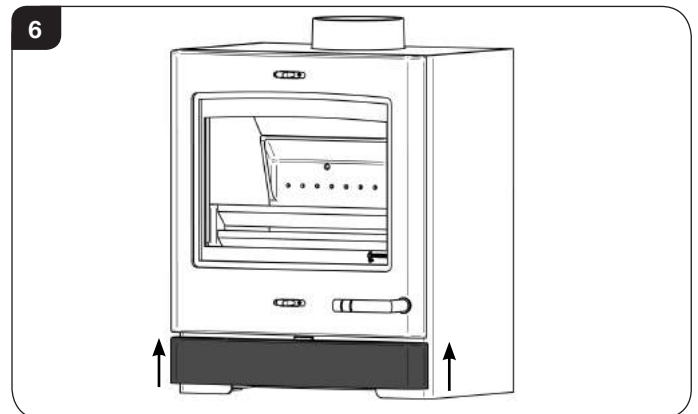

- 5.5 Pull the Cast Plinth clear of the carcass, see Diagram 7.

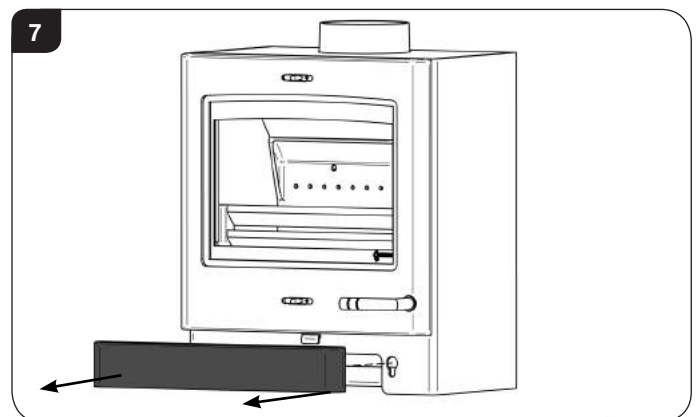

Installation Instructions

1. Installing the Appliance

Each installation is unique to the property so it is not possible to give details to suit every setting. The installation must comply with Building Regulations† and be made using "best practice" construction methods‡.

Many fireplace openings have a supporting lintel. Do not remove without supporting the remaining structure of the building. **Do not support the structure or the flue system with the appliance.**

The flue system must be fully installed and supported according to the manufacturers instructions BEFORE the appliance is installed.

1.1 **Take care when installing the appliance. Careless handling and use of tools can damage the finish and/or area.**

Choose top or rear flue exit, Diagram 1.

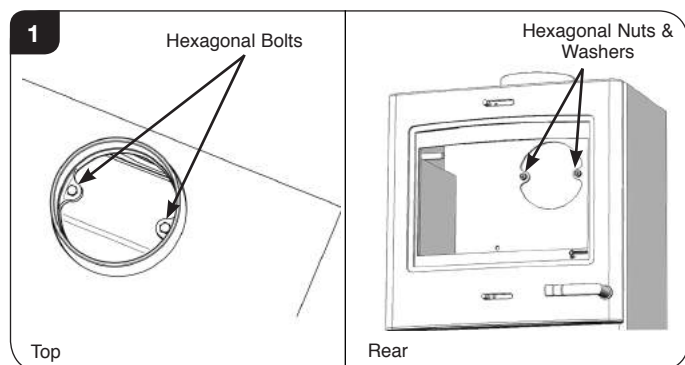

- Fit flue collar and blanking plate to suit.
- Attach flue collar to top or rear with hexagonal bolts, see Diagram 1.
- Seal collar with fire cement.
- Secure blanking plate with hexagonal bolts, Diagram 2.

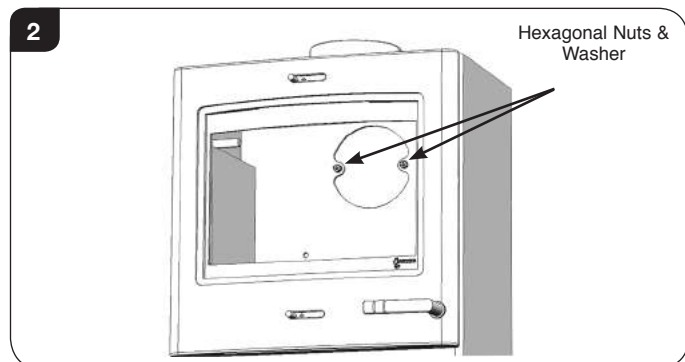

† England and Wales – Document J / Scotland - Part F/Document J (Republic of Ireland only)
‡ the latest edition of BS 8303, BS EN 15287, BS 7566

2. Hearth Fixing

The appliance must be fixed to the hearth in at least two positions. There are various hearth mount locking methods detailed in this section depending on the appliance model.

CL3, CL5 & CL8 models

- 2.1 Position the appliance where required on the hearth and mark the location of the two fixing holes in the hearth mounts.
- 2.2 Drill the required sized holes into the hearth.
- 2.3 Use suitable fasteners to fix in place.

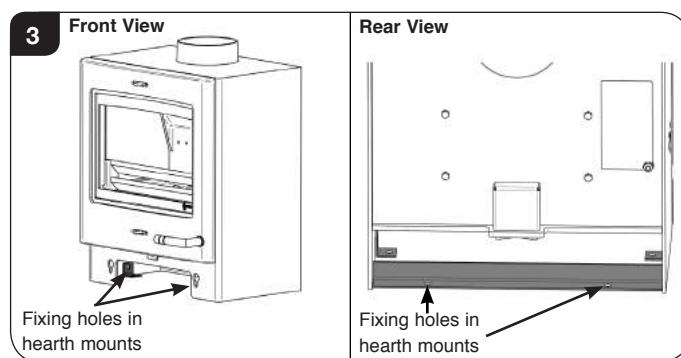

- 2.4 If access underneath or to the rear of the appliance is hampered 2 L shaped brackets are provided. These brackets can be attached to the side of the appliance and then secured to the hearth by following these steps:

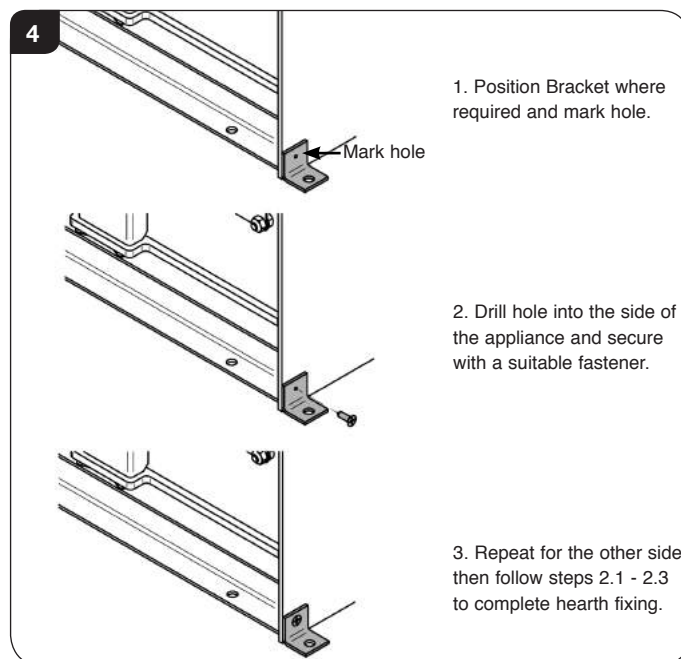

Installation Instructions

CL5 Midline & Highline models

The CL5 Midline & Highline models have two holes, one in each of the rear corners of the base plate of the log store which can be used for hearth fixing, see Diagram 5.

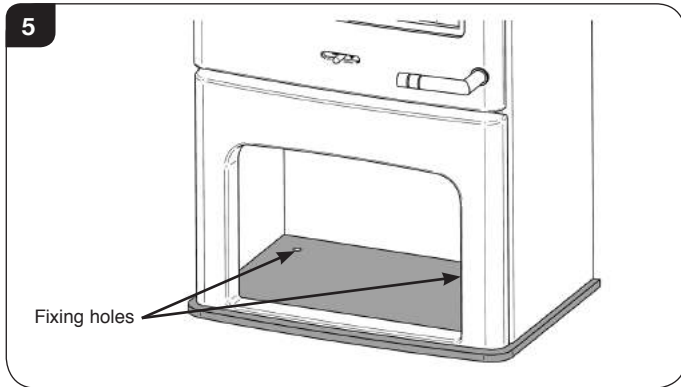

- 2.5 Position the appliance where required on the hearth and mark the location of the two fixing holes in the hearth mounts.
- 2.6 Drill the required sized holes into the hearth.
- 2.7 Use suitable fasteners to fix in place.

3. Flue Pipe Installation

3.1 Top flue pipe installation

- Lift appliance into position.
Take care not to damage the hearth finish.

- Level the appliance.

If there is a Cast Top option to be fitted this must be done before the flue connection - see Section 6.

Connect appliance to the chimney using flue pipe.

- Secure with self tapping screw.
- Seal the connecting joints with fire cement.

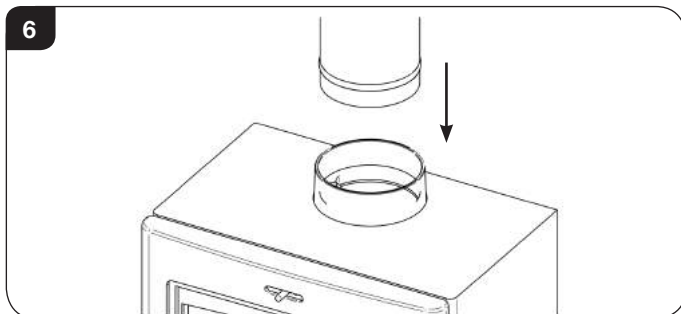

The Flue must be installed in accordance with manufacturers instructions.

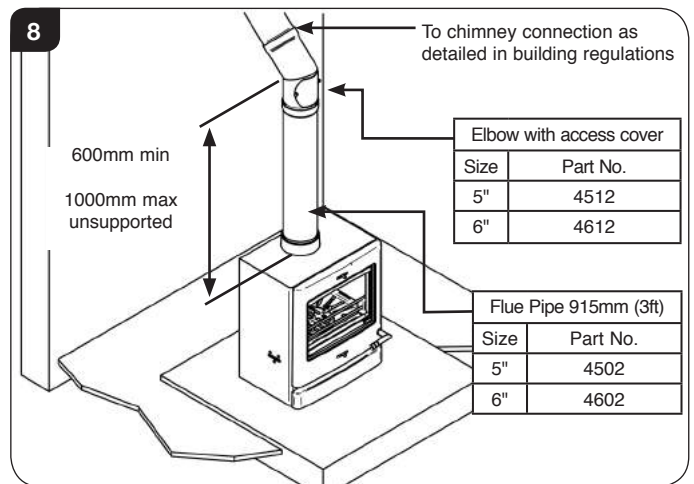
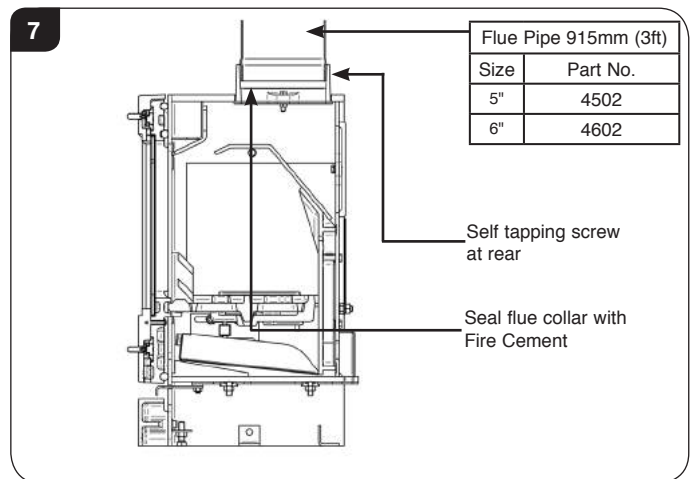

3.2 Rear flue pipe installation

- Insert a tee into the flue collar.
The tee piece is used as cleaning access.
- Lift appliance into position.
Take care not to damage the hearth finish.
- Level using adjustable bolts.
- Connect tee to the chimney using flue pipe.
- Secure with self tapping screw.
- Seal the connecting joints with fire cement.

Do not use a 90° elbow to make this connection.

The Flue must be installed in accordance with manufacturers instructions.

i † England and Wales – Document J / Scotland - Part F/Document J (Republic of Ireland only)
‡ the latest edition of BS 8303, BS EN 15287, BS 7566

Installation Instructions

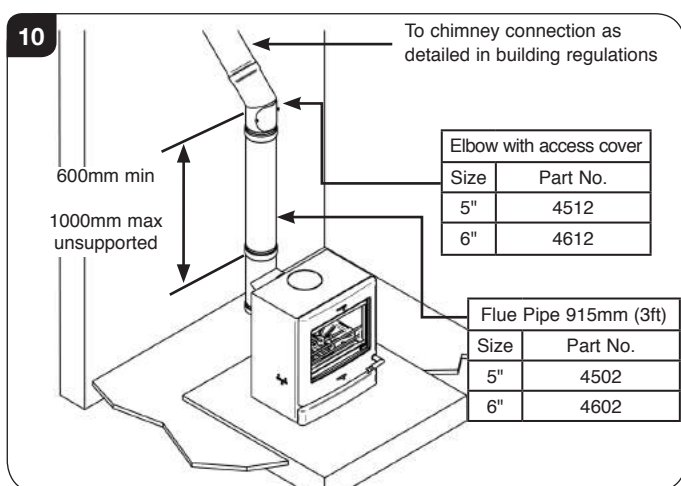
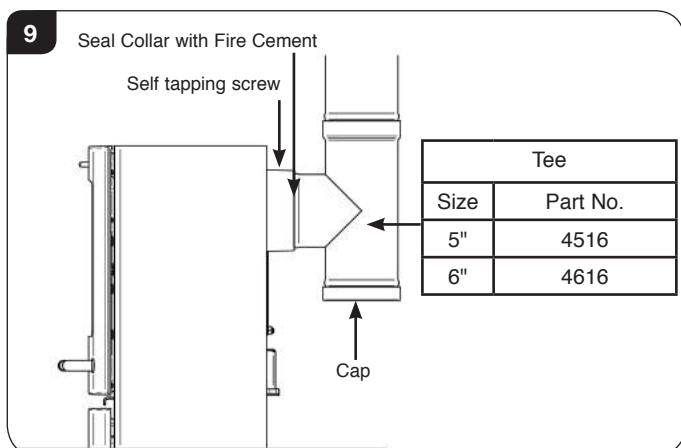

4. Smoke Control Kit

- 4.1 Some of these appliances can be modified to burn wood in a smoke control zone. For more details on the Smoke Control Kit for this appliance contact your retailer.

NOTE: These appliances have been independently tested to PD6434 and have been exempt from the controls that generally apply in smoke control areas hence are considered suitable for use in Smoke Control Area when burning wood and ONLY when fitted with the relevant Smoke Control kit.

5. Removal of Riddling Mechanism

To maintain good working condition the multi-fuel grate can be removed for cleaning.

- 5.1 Remove ashpan, log guard, baffle and firebricks (see pre-installation sections 2, 3 & 4).
 5.2 Remove centre grate, see Diagram 11.

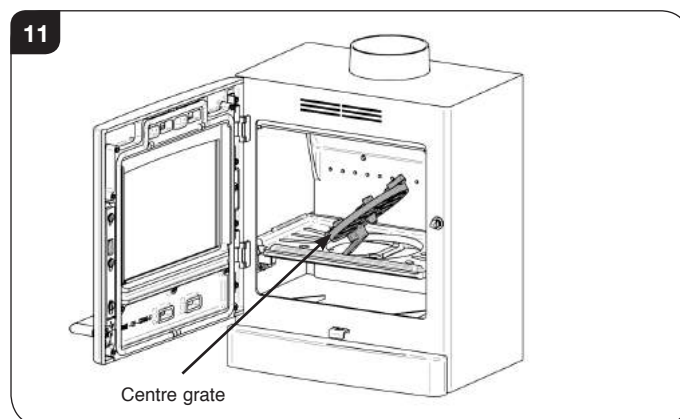

- 5.3 Remove main grate, see Diagram 12.

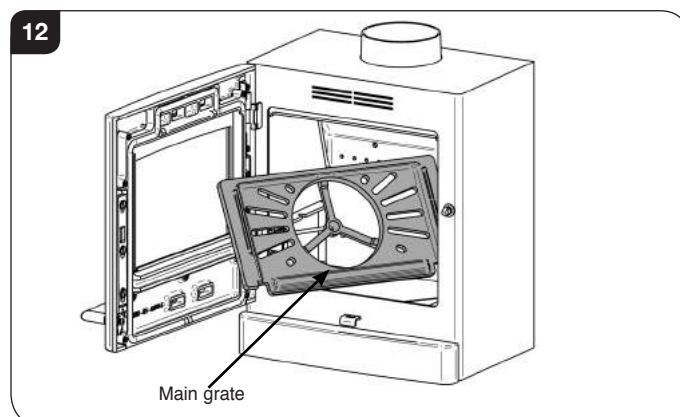

- 5.4 Remove riddling slider and connecting rod by unscrewing the 6 x M8 nuts using a 10mm A/F spanner, see Diagram 13.

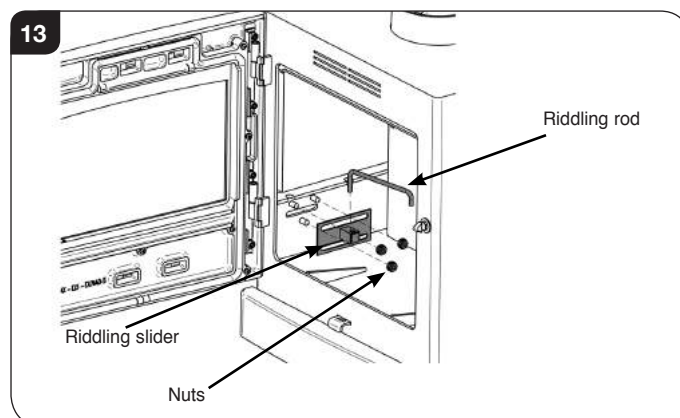

- 5.5 Replace in reverse order.

Installation Instructions

6. Cast Top

This appliance can be fitted with an optional cast top plate. The type of plate will depend on whether the appliance is installed with a top* or rear flue exit.

	Top Flue	Rear Flue
CL3	YM-CL3CT	YM-CL3CTR
CL5	YM-CL5CT	YM-CL5CTR
CL5 Midline	YM-CL5CT	YM-CL5CTR
CL5 Highline	YM-CL5CT	YM-CL5CTR
CL8	YM-CL8CT	YM-CL8CTR

* The cast top must be fitted at the same time as the flue connection (see Installation Instructions, Section 3).

- 6.1 The cast top plate has 4 cast feet on the bottom to space it off the top of the appliance by 6mm and allow the door to open freely.

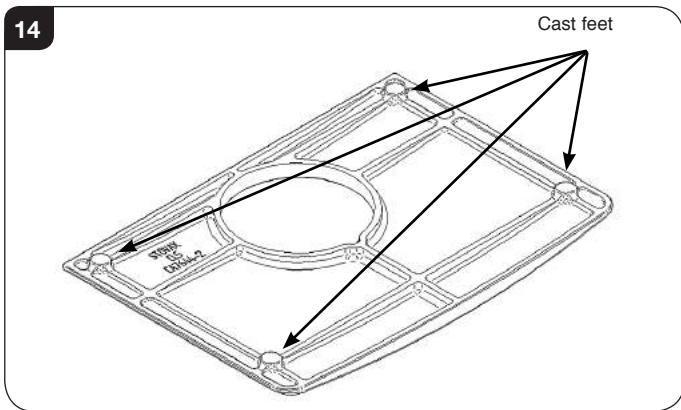

- 6.2 Place the cast top plate feet down on top of the appliance.
- Ensure the cast top is flush with the front and sides of the appliance.
 - For the top flue version, position the cutout over the flue ring.

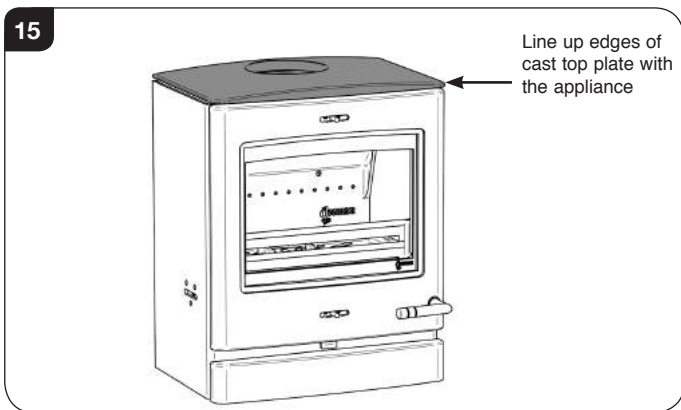

7. CO Alarms

All open flued appliances can be affected by temporary atmospheric conditions which may allow fumes to enter the house. **Building regulations require that whenever a new or replacement fixed solid fuel or wood/biomass appliance is installed in a dwelling a carbon monoxide alarm must be fitted in the same room as the appliance. Further guidance on the installation of the carbon monoxide alarm is available in the latest edition of BS EN50292 and from the alarm manufacturer's instructions.**

HETAS recommend the unit is permanently fixed in accordance with the manufacturer's installation instructions or with the guidance contained in Approved Document J where no other information is available.

Provision of an alarm must not be considered a substitute for either installing the appliance correctly or ensuring regular servicing and maintenance of the appliance and chimney system.

Commissioning

1.1 To commission:

- Replace internal components.
- Check the door alignment and catch operation and adjust if required (see Maintenance & Servicing, *Section 5&6*).
- Check the soundness of door seals, castings and joints.
- Check the operation of the air controls.

1.2 Now carry out a final smoke draw test:

- Warm the flue with a blowlamp, or similar, for about 10 minutes.
- Place a smoke pellet on the centre of the grate, with the air controls open.
- Close the door. Smoke should now be drawn up the flue and be seen to exit from the flue terminal.
- Complete test with all doors and windows closed in the room where the appliance is fitted.
- If there are any extractor fans in adjacent rooms the test must be repeated with the fans running on maximum and with interconnecting doors open.
- Check the effect of ceiling fans during the test.

If the test fails, re-check the suitability of the flue system and ventilation. An inadequate air supply to the room is potentially dangerous.

- Light the appliance and slowly increase the temperature.
- Ensure no combustion products enter the room.
- Open the main fire door when the appliance reaches operating temperature and carry out a spillage test with a smoke match or pellet around the door opening.

1.3 If excessive spillage occurs allow the appliance to cool and re-check the flue system and ventilation.

1.4 Finally:

- Explain to the user the safe operation of the appliance, use of the controls and the importance of only using suitable fuels.
- Ensure that a CO alarm has been fitted and make the user aware of its operation and importance, referring them to the Warning section on page 5 of the User Instructions.
- Explain the cleaning and routine maintenance requirements.
- Explain the requirement to use a suitable fireguard when children, elderly or infirm persons are near the appliance.
- Record retailer/supplier and installer details in Appliance Commissioning Checklist (page 3, Instructions for Use).
- Record serial number in Appliance Commissioning Checklist (page 3, Instructions for Use).

This number is required when ordering spare parts and making warranty claims.

- Give this instruction manual to the customer.

Certificate Of Compliance

Upon completing the installation, the form below must be filled in by your installer to comply with the requirements of HETAS and the building regulations. The installer must give these details, including their HETAS registration number, for the purposes of any insurance details that may change as a result of the appliance being installed.

HETAS LTD - CERTIFICATE OF COMPLIANCE

PLEASE TICK APPROPRIATE BOXES OR ENTER DETAILS IN BOXES BELOW



Record ID (HETAS Use Only)	<input type="text"/>	(*indicates that this data must be given)
Customer Name	*	
Installation Address	*	
Installation Address		
Installation Address		
Installation Address		
Town	*	
Postcode	*	Work Completion Date *
Local Authority Name (*Must be given if no postcode available)		
Installing Company Name	*	Company's HETAS Reg. No. *
Installing Engineer's Name	*	Engineer's HETAS Reg. No. *

Description of Work	
Location:	Lounge <input type="checkbox"/> Dining Room <input type="checkbox"/> Kitchen <input type="checkbox"/> Utility Room <input type="checkbox"/> Bedroom <input type="checkbox"/> Other, Specify <input type="text"/>
Appliance:	Dry Open Fire <input type="checkbox"/> Open Fire with Boiler <input type="checkbox"/> Dry Cooker <input type="checkbox"/> Cooker with Boiler <input type="checkbox"/> Dry Roomheater/Stove <input type="checkbox"/> Roomheater/Stove with Boiler <input type="checkbox"/> Independent Boiler <input type="checkbox"/> Make <input type="text"/> Model <input type="text"/> Heat Output <input type="text"/> kW
System:	New Heating and Hot Water System <input type="checkbox"/> Updated Existing Heating and Hot Water System <input type="checkbox"/> Dry System Only <input type="checkbox"/>
If Wet System:	Is the Hot Water System Unvented? <input type="text" value="Y/N"/>
Chimney:	New Insulated Factory Made Chimney System Installed <input type="checkbox"/>
Relining of existing chimney:	Twin Wall Flexible Liner (for Class 1 Appliance) <input type="checkbox"/> Cast In-situ Liner <input type="checkbox"/> Rigid Sectional Liner Metal <input type="checkbox"/> Rigid Sectional Liner Other <input type="checkbox"/>
Hearth:	New Hearth/Surround fitted <input type="checkbox"/> Existing Hearth Surround Updated <input type="checkbox"/>

Additional Information	
Connecting fluepipe:	Diameter <input type="text"/> mm Socket joints upward and gas tight <input type="text"/>
	Provision for sweeping chimney/fluepipe: Yes <input type="checkbox"/> No <input type="checkbox"/> Chimney Data Plate Location *
Air supply:	Has a permanently open air vent been fitted: Yes <input type="checkbox"/> No <input type="checkbox"/>
	Is vent opening at least 50% of cross sectional area of throat/flue <input type="text"/> or State total free area of air vent <input type="text"/> mm ²
	Confirm an approved Carbon Monoxide alarm has been fitted <input type="checkbox"/>

Testing & Commissioning to Approved J Appendix E
Confirm you have commissioned and tested the appliance & associated work for safe and efficient operation <input type="checkbox"/>

<p>Declaration of completion As the competent person responsible for the work described above, I confirm that the appliance and associated work has been installed in accordance with the HETAS rules of registration, and that the work complies with Regulations 4 and 7 of the Building Regulations, and Approved Documents J, G & L as applicable.</p> <p>Signed: _____ Print name: _____ Date: _____</p> <p>COPIES OF THIS COMPLETED CERTIFICATE MUST BE (WHITE COPY) SENT TO HETAS LTD AT THE ADDRESS GIVEN BELOW (PINK COPY) GIVEN TO THE CUSTOMER FOR RETENTION (YELLOW COPY) RETAINED BY THE INSTALLING COMPANY</p>

THIS CERTIFICATE SHOULD BE RETAINED BY THE PROPERTY OWNER
WHO MAY BE REQUIRED TO PRODUCE IT IN ANY FUTURE SALE OF THE PROPERTY.

Maintenance & Servicing

For a complete list of spare parts and accessories contact your Yeoman retailer or call 01392 474011

1. Annual Service

- 1.1 Before the start of the heating season strip, inspect and clean the appliance as detailed:
- Allow appliance to cool.
 - Remove all internal parts and, for multi-fuel versions, grate system and ashpan (see Installation Instructions, Sections 3). Take care handling firebricks as they can become fragile after a period of use.
 - Sweep the appliance at this point if necessary.
 - Vacuum clean any remaining ash and debris from the inside of the appliance. Yeoman offer a filter/collection attachment for vacuum cleaners to protect them from fire ash: Ash Clean (Part No. 2091).
 - Clean the internal surfaces of the appliance using a wire brush and scraper as required. Vacuum and brush the resulting debris from the appliance.
 - Clean the grate parts (multi-fuel) with a wire brush.
 - Check the parts for any damage. Replace any damaged parts using genuine Yeoman replacements parts.
 - Check and clean the firebricks with a soft brush. Some surface damage will occur during use. The life of the bricks will depend on the type of fuels burnt and the level of use. **Replace damaged bricks as soon as possible.**
 - Re-fit cleaned internal parts.
 - Remove glass from door, discard all old rope seals and fit new (see Maintenance and Servicing, Section 5).
 - Clean the door glass using Stovax Glass Cleaner and a soft cloth.
 - **On appliances with printed glass do not use cleaning agents that have a high alkaline or acidic content, for example Stovax Gel Cleaner, these are aggressive cleaning agents designed to be used with heavily stained clear glass. On printed glass surfaces, use Stovax Glass Cleaner (Stovax No.4103) which is better formulated for this application.**
- Do not use abrasive cleaners to remove tar or soot deposits from the glass.**
- Fit new door rope seal (see *Maintenance and Servicing, Section 4*).
 - Lightly oil the door catch mechanism and hinge pins. Avoid getting oil onto the door seals and glass.
 - To refresh painted finishes a touch up spray is available. Contact your Yeoman retailer quoting the serial number found on the appliance data badge.

- 1.2 Use genuine Yeoman replacement parts to keep the appliance in safe, efficient working order. This is a list of the maintenance products that may need be required:

Task	Product name
Preventing build-up of creosote in flue	Protector (15 sachets)
	Protector (1kg tub)
Sealing flue pipe joints	Fire Cement (500g tub)
	Fire Cement (600g cartridge)
Re-painting	Touch Up Aerosol (150ml aerosol)
Protecting your hands	Heat resistant leather gloves
Thermic seal glue	(50ml bottle)
Ash Clean	Vacuum Cleaner Attachment
Cleaning Glass	Gel Cleaner
	Glass Cleaner (Stovax no. 4103)

These products, available online at www.yeomanstoves.co.uk or from your local Yeoman Retailer, along with regular maintenance and use of correct fuels, will keep the appliance in the best possible condition.

- 1.3 For more information about the Yeoman products please visit our web site at www.yeomanstoves.co.uk.
- 1.4 Burn at a low temperature for the first day of use after any maintenance. This allows the seals, fixing glues and paint to fully cure.
- 1.5 During this time the appliance may give off some unpleasant odours. Keep the room well ventilated to avoid a build-up of fumes.
- 1.6 Your Yeoman Retailer can carry out service and maintenance.

2. Removal of Internal Parts

- 2.1 To service and maintain the good working condition of your appliance it will be necessary to remove several internal parts. Consult the installation section for the following:
- Log Guard** - Pre-Installation Section 2, page 19.
 - Baffles** - Pre-Installation Section 3, page 20.
 - Firebricks** - Pre-Installation Section 4, page 20.

Maintenance & Servicing

3. Fitting a new Door Glass - All Models

To maintain safe use of the appliance damaged door glass must be replaced immediately.

To do this:

- 3.1 Remove the door by opening past 45° to avoid hitting the hinge blocks, then lift free from the hinge mechanism.
- 3.2 Lay the door face down on a soft flat surface to protect the paintwork, glass and controls.
- 3.3 Remove the glass clamp and 8 x screws and washers. The old glass can then be lifted clear of the door.

Note how the sealing rope is placed around the glass.

- 3.4 **Dispose of the old glass safely.**

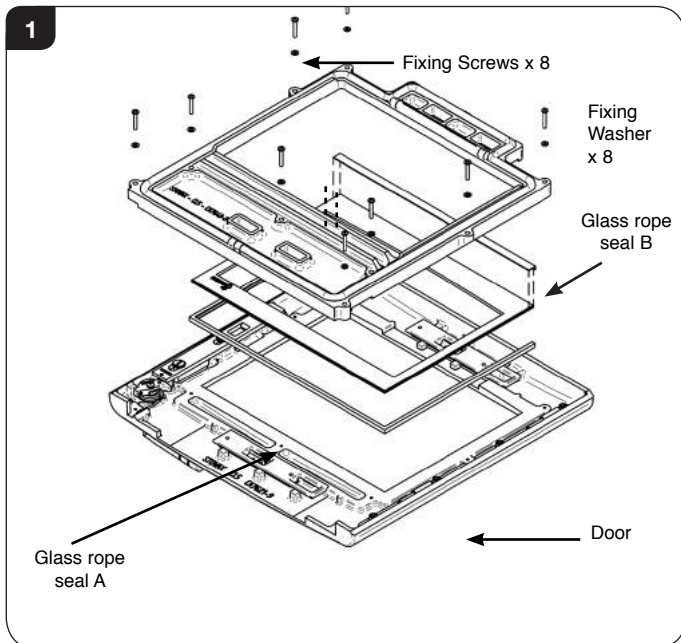

Seal	Length (mm)		
	Yeoman CL3	Yeoman CL5	Yeoman CL8
Glass rope seal A	930	1025	1220
Glass rope seal B	255	340	460

- 3.5 Clean, and re-paint, the rear of the door if required ensuring all old glue is removed from rope seal channel.
- 3.6 Clean the screws with light oil and coat with high temperature anti-seize grease to aid future removal.

- 3.7 Carefully wrap glass sealing rope (A) round the sides and bottom edge of the glass, see Diagram 2.

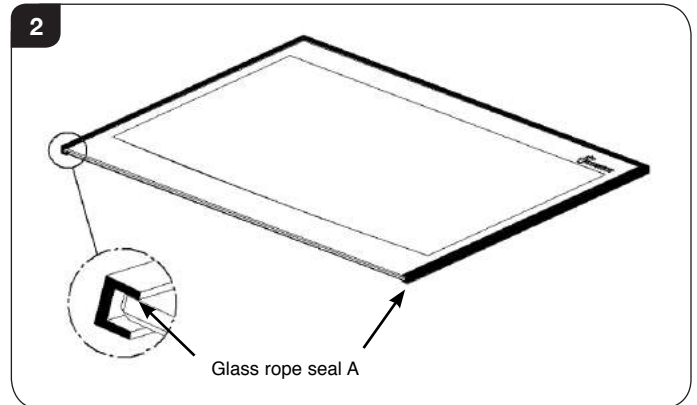

- 3.8 Fix glass sealing rope (B) to the matt black side of the top face, see Diagram 3.

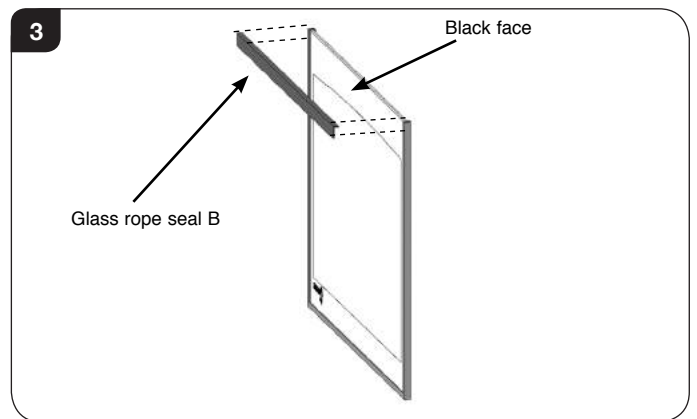

- 3.9 Place the glass into position in the door.
- 3.10 Place the glass clamp into position and re-fix with the clean fixing screws, tightening the screws evenly until glass is held securely.
- 3.11 **Do not over tighten the clamp as this could break the glass.**
- 3.12 Fit only original Yeoman ceramic glass, which is suitable to use in high temperature applications.
- 3.13 Using the appliance with damaged door glass could cause dangerous fumes to enter the room or the appliance to over-fire resulting in damage.

Maintenance & Servicing

4. Fitting a new Door Seal

To maintain the safe use of the appliance damaged or worn door sealing rope must be replaced.

To do this:

- 4.1 Remove the door by opening past 45° to avoid hitting the hinge blocks, then lift free from the hinge mechanism.
- 4.2 Lay the door face down on a soft flat surface to protect the paintwork, glass and controls.
- 4.3 Remove old rope and scrape old glue from locating groove.

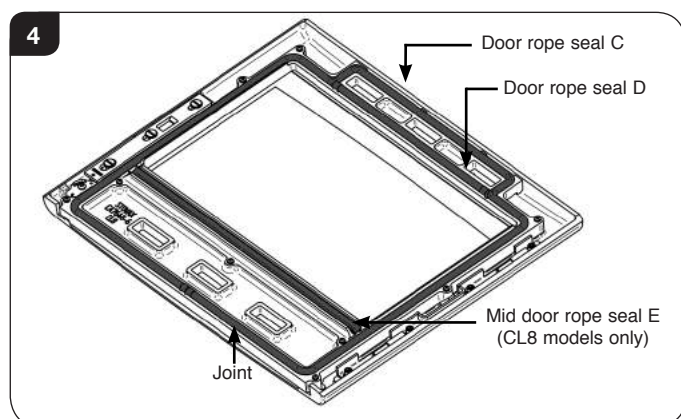

Seal	Length (mm)		
	Yeoman CL3	Yeoman CL5	Yeoman CL8
Door rope seal C	1400	1600	2300
Door rope seal D	175	175	410
Mid door rope seal E (CL8 models only)	n/a	n/a	450

- 4.4 Clean the locating groove with a clean, dry cloth to remove all old dust and debris.
- 4.5 Squeeze a generous bead of fresh Thermic Seal glue into the rope locating groove.
- 4.6 Press the new rope into the locating groove, placing the joint in the middle of the lower edge of the door.
- 4.7 Refit door and close to apply pressure to new rope.
- 4.8 Leave the door(s) closed for at least 12 hours before lighting the appliance and run at a low temperature for approximately one day. This allows the adhesive to fully bond to the seal.
- 4.9 Using the appliance with a damaged door seal can cause dangerous fumes to enter the room, or the appliance to over fire resulting in damage.

5. Adjusting the Door Hinges

To maintain the safe use of your appliance, you may need to adjust the door hinges to ensure the door closes safely and correctly.

To adjust the **door hinge plate assembly**:

- 5.1 Remove the door by opening past 45° to avoid hitting the hinge blocks, then lift free from the hinge mechanism.
- 5.2 Lay the door face down on a soft flat surface to protect the paintwork, glass and controls.

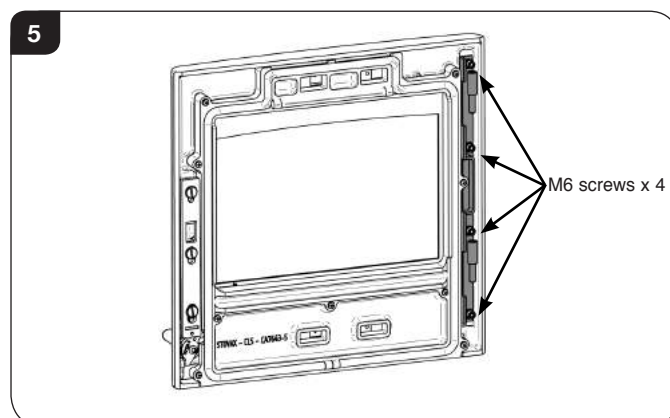

- 5.3 Use an M6 hexagon key to loosen the 4 x M6 screws.
- 5.4 The hinge plate assembly is slotted so it can be moved up, down and sideways by approximately 3mm to adjust the position of the door in relation to the appliance.
- 5.5 Once the desired position has been achieved ensure the screws are firmly tightened against the hinge plate assembly to maintain the position.

6. Adjusting the Door Catch

To adjust the **door catch**:

- 6.1 Open the door to gain access to the catch.

If the door cannot be opened with the handle/ multifunctional tool, pull the door with one hand and carefully insert a small flat head screwdriver into the slot in the door catch slider, see Diagram 6.

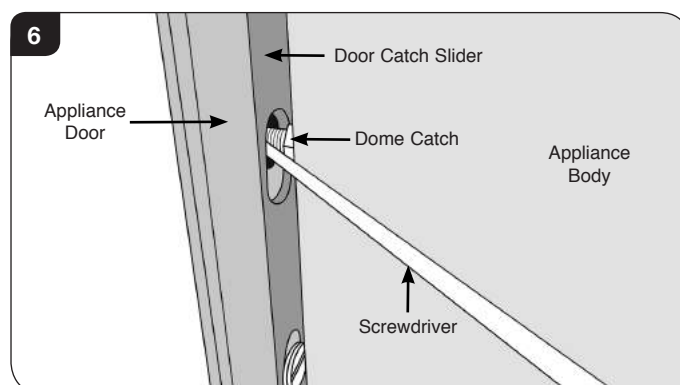

Maintenance & Servicing

Lift the door catch slider until it disengages from the dome catch and the door opens.

- 6.2 Use a 13mm A/F spanner to loosen the half lock nuts either side of the appliance body. This will allow the dome catch to rotate in and out and move up and down, see Diagram 7.

DO NOT undo the catch more than 3-4mm.

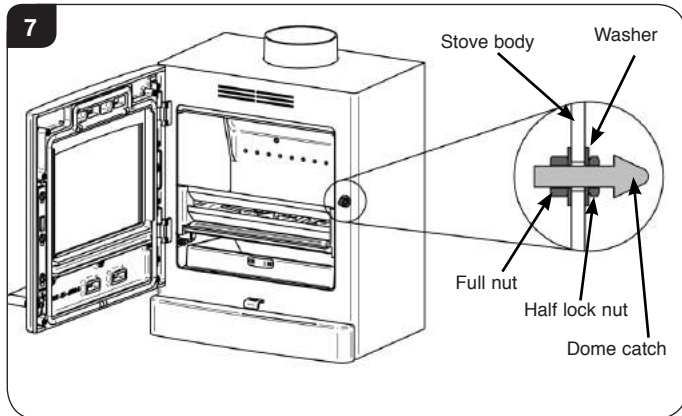

- 6.3 Ensure the dome catch is in an upright position with the flat sides parallel with the side of the stove, see Diagram 8.

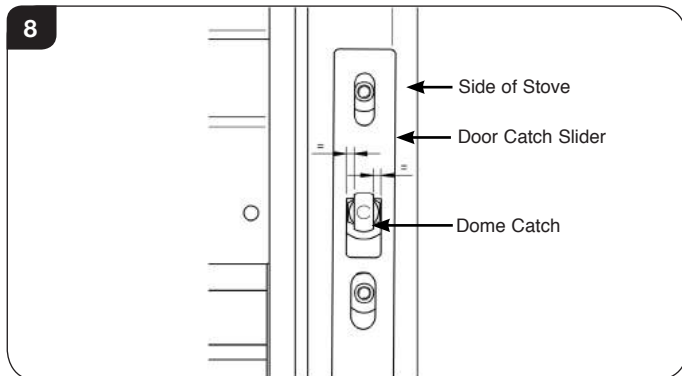

When the door closes the Dome Catch should sit centrally in the slot of the door catch slider.

- 6.4 Adjust the height of the catch so that the door locking mechanism makes contact slightly above the point of the Dome Catch, see Diagrams 9, 10 & 11.

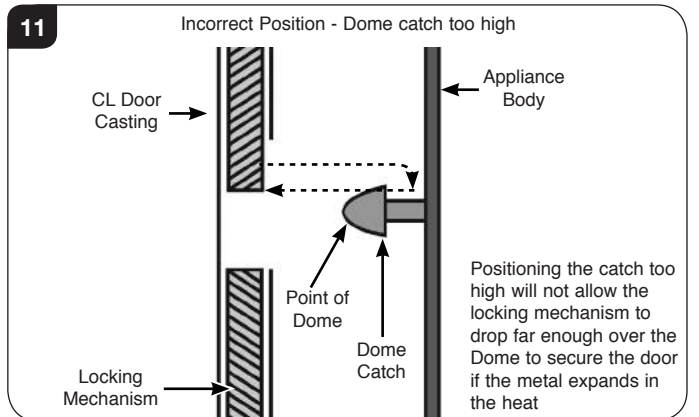
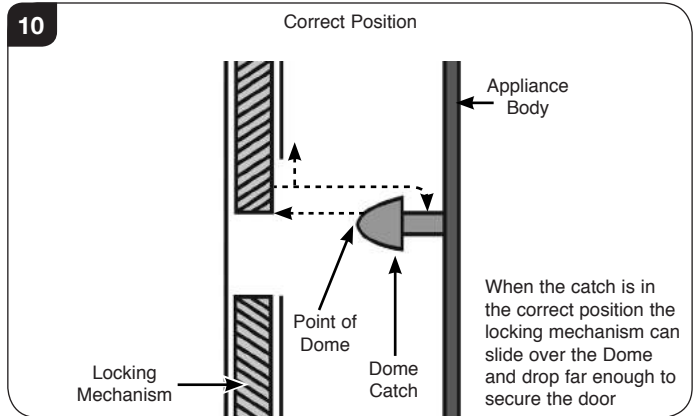
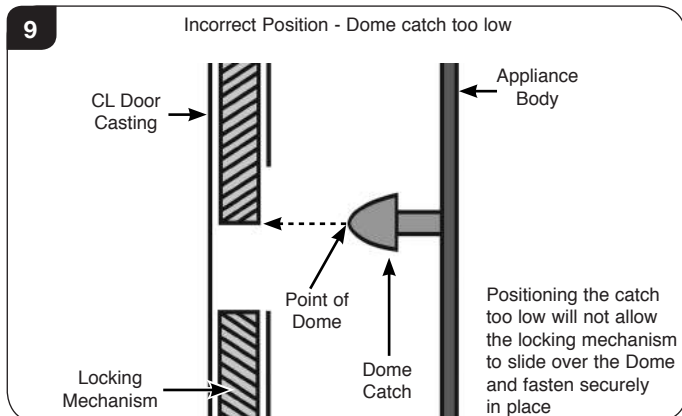

- 6.5 To ensure a firm hold by the locking mechanism, the catch should be positioned to allow the maximum distance of travel up and down over the tapered end of the catch.

Note: If the point of the Dome Catch is in line with the bottom of the locking mechanism this will prevent the door from being pushed closed, too high and the catch won't travel far enough down the other side of the catch to hold the door if the metal expands when hot.

- 6.6 Fully tighten the lock nuts to secure the Dome Catch.
6.7 Open and close the door several times to check the adjustment.

7. Final Checks

- 7.1 Following these adjustments check that the door:
- Does not come into contact with the grate or log guard.
 - Can be pushed shut without operating the door handle.
 - Passes the paper sealing test.
 - Aligns with the side and top of the appliance.

Legal Requirements

Before installation and/or use of this appliance please read these instructions carefully to ensure that all requirements are fully understood.

The appliance must be fitted by a registered installer*, or approved by your local building control officer.

It is very important to understand the requirements of the national Building Regulations† and standards‡, along with any local regulations and working practices that may apply. Should any conflict occur between these instructions and these regulations then the regulations must apply.

Your local Building Control Office can advise regarding the requirements of the regulations.

i † England and Wales – Document J / Scotland - Part F/Document J (Republic of Ireland only)
‡ the latest edition of BS 8303, BS EN 15287, BS 7566

***Registered on the Competent Persons Scheme (GB only) see page 34/ INFO (Republic of Ireland).**

Works must be carried out with care to meet the requirements of Health and Safety and comply with the Health and Safety rules, and any new regulations introduced during the lifetime of these instructions. Particular attention should be drawn to:

- **Handling:** The appliance is heavy. Adequate facilities must be available for loading, unloading and on site handling.
- **Fire Cement:** Some fire cement is caustic and must not come into contact with the skin. Protective gloves must be worn. Wash hands thoroughly with plenty of water after contact with skin.
- **Asbestos:** This appliance contains no asbestos. If there is the possibility of disturbing any asbestos in the course of installation seek specialist guidance and use appropriate equipment.
- **Metal Parts:** Take care when installing or servicing the stove to avoid personal injury.

A faulty installation can cause danger to the inhabitants and structure of the building.

For users of this appliance:

Your building insurance company may require you to inform them that a new heating appliance has been installed on your property. Check that your cover is still valid after installing the appliance.

Flue Outlet Positions

These positions are defined by Document J of the Building Regulations.

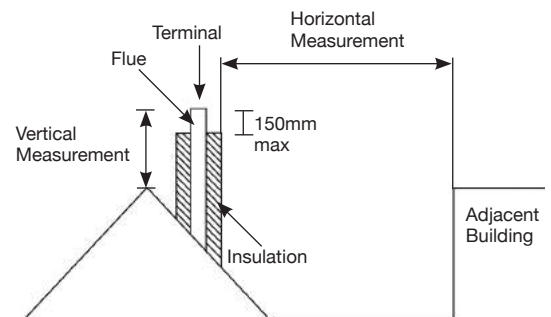
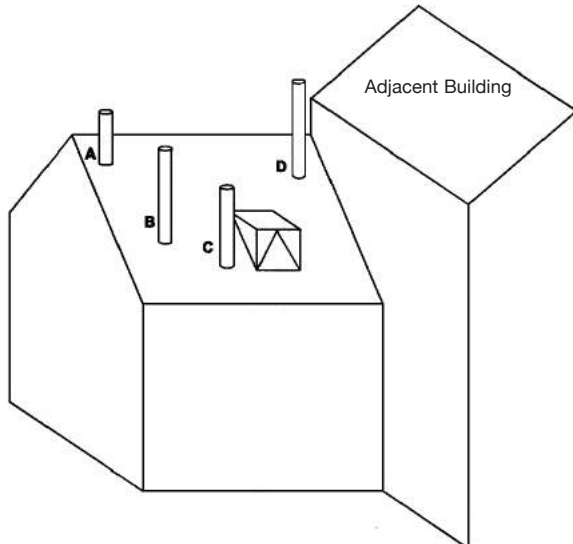

The datum for vertical measurement is the point of discharge of the flue from either the point of discharge of the flue or 150mm above insulation, whichever is the lower.

IMPORTANT: Seek specialist advice if installing in a dwelling with a thatched roof

Point where the flue passes through weather surface (Notes 1 & 2)		Clearances to flue outlet
A	At or within 600mm of the ridge	At least 600mm above ridge
B	Elsewhere on roof (whether pitched or flat)	At least 2300mm horizontally from the nearest point on the weather surface and: a) at least 1000mm above highest point of intersection of the chimney and the weather surface; or b) at least as high as the ridge
C	Below (on a pitched roof) or within 2300mm horizontally to openable rooflight, dormer window, or other opening (Note 3)	At least 1000mm above the top of opening
D	Within 2300mm of an adjoining or adjacent building, whether or not beyond the boundary (Note 3)	At least 600mm above any part of the adjacent of building within 2300mm

1) The weather surface is the building external surface, such as it's roof tiles or external walls.
2) A flat roof has a pitch less than 10°.
3) The clearance given for A or B, as appropriate, will also apply.
4) A vertical flue fixed to an outside wall should be treated as equivalent to an inside flue emerging at the nearest edge of the roof.

Technical Appendix - Flues

2. Flue or Chimney

- 2.1 The flue or chimney system must be in good condition. It must be inspected by a competent person and passed for use with the appliance before installation.

Products of combustion entering the room can cause serious health risks.

- 2.2 The following must be checked:

- The construction of the masonry chimneys, flue block chimneys and connecting flue pipe system must meet the requirements of the Building Regulations†.
- A flexible flue liner system can be used if certified for use with solid fuel systems and installation complies with manufacturer's instructions and Building Regulations. The flue liner must be replaced when an appliance is replaced, unless proven to be recently installed and in good condition.
- If it is necessary to fit a register plate it must conform to the Building Regulations†.
- The minimum height of the flue or chimney must be 4.5m from the hearth to the top of the flue, with no horizontal sections and a maximum of 4 bends. Bends must have angles of less than 45 degrees from the vertical.
- There should be at least 600mm of vertical flue pipe above the appliance before any bends are introduced.
- Ensure the connecting flue pipe is kept a suitable distance from any combustible material and does not form part of the supporting structure of the building.
- The installer must ensure the flue pipe diameter is not less than the diameter of the outlet of the appliance and does not narrow to less than the size of the outlet at any point in the system.
- Make provision to remove the appliance without the need to dismantle the chimney.
- Any existing flue must be confirmed as suitable for the new intended use as defined in the Building Regulations.
- The flue or chimney systems must be inspected and swept to confirm the system is structurally sound and free from obstructions.
- If the chimney is believed to have previously served an open fire it must be swept a second time within a month of regular use after installation to clear any soot falls that may have occurred due to difference in combustion levels.
- The flue exit from the building must comply with local building control rules†.
- Chimney heights and/or separations may need to be increased in particular cases where wind exposure, surrounding tall buildings, high trees or high ground could have adverse effects on flue draught.
- Do not connect or share the flue or chimney system with another heating appliance.

- 2.3 Do not connect to systems containing large voids or spaces over 230mm square.
- 2.4 Suitable access must be provided to enable the collection and removal of debris.
- 2.5 The flue must be swept and inspected when the appliance is installed.

Flue Draught

The flue draught must be checked with all windows and doors closed and any extraction fans in this, or adjoining rooms, running at maximum speed (see Installation Checklist for ventilation requirements).

Twin Wall Flue System

If this appliance is to be used in conjunction with a twin wall flue system then Stovax recommend the use of their Professional XQ range. Details of this product are available from your Stovax retailer.



In the U.K:

***BS 15287-1 and the requirements of Building Regulations**

****This should be done by a NACS registered (UK only)/INFO registered (Eire only) chimney sweep, who will issue you with a certificate.**

† Building Regulations Document J

Flue Plate:

Where a hearth, fireplace, flue or chimney is provided or extended (including cases where a flue is provided as part of refurbishment work), information essential to the correct appliance and use of these should be permanently posted in the building, to meet Requirement J4 of the Building Regulations (England and Wales), F3.12 (Scotland).

Additional:

A new factory made system that complies to EN 1856; Part 1 can be used providing installation is to the requirements of:

- i) BS 7566 Parts 1 -4**
- ii) the manufacturer's instructions**
- iii) Building Regulations.**

For a guide containing information on Chimneys and Flues contact:

**The British Flue & Chimney Manufacturers' Association,
FETA
2 Waltham Court
Milley Lane
Hare Hatch
Reading
Berkshire RG10 9TH**

Tel: 0118 9403416

e-mail: info@feta.co.uk

Ventilation - Technical Appendix

2. Ventilation

- 2.1 Many older buildings are sufficiently ventilated by natural leakage of air to provide suitable air supply for an appliance of 5kW output or less.

Modern building techniques have reduced the amount of air that leaks in or out of a house. A modern construction with an air tightness of less than 5m³ per hour per m² requires an air vent for **ALL** solid fuel appliances including those with a rated heat output of less than 5kW.

NOTE: The air leakage of a modern house is tested at the completion of construction and a certificate issued confirming this.

- 2.2 This appliance requires a constant supply of air to maintain proper combustion and effective flue performance.
- 2.3 An inadequate air supply can result in poor combustion and smoke entering the room which is potentially dangerous.
- 2.4 This supply of air can come from either:
- Purpose provided ventilation.
 - Some Yeoman appliances can also be fitted with an optional outdoor air kit which allows air to be drawn in from the outside.
- 2.5 The amount of air required must comply with local building regulations and the rules in force.
- 2.6 If spillage is detected during commissioning then there may be insufficient natural ventilation and an additional air supply will be necessary.
- 2.7 Permanent air vents should be non-adjustable and positioned where they are unlikely to become blocked.
- 2.8 If vents open into adjoining rooms or spaces there must be an air vent of at least the same size direct to the outside.
- 2.9 Site the vents where cold draught is unlikely to cause discomfort. This can be avoided by placing vents near ceilings or close to the appliance (See diagram).
- 2.10 Extractor fans or cooker hoods must not be placed in the same room or space as this can cause the appliance to emit fumes into the room.
- 2.11 Increase air supply provisions where a room contains multiple appliances.
- 2.12 **If any checks reveal problems do not proceed with the fitting of the appliance until they have been rectified.**

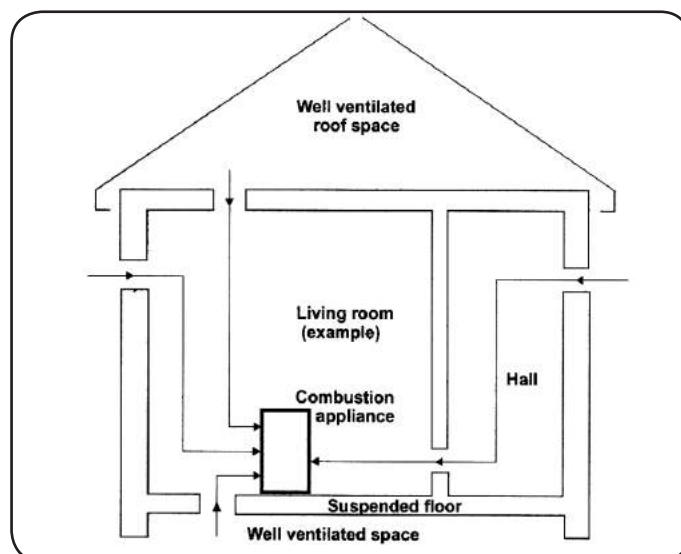

3. Minimum Dimensions - Hearth

- 3.1 The appliance must stand on a non-combustible constructional hearth which is at least 125mm thick with the minimum dimensions as shown in diagram. As this appliance can be installed in an elevated setting it is recommended to increase the 225mm hearth depth to safely contain any falling logs or embers. The higher the appliance is installed the deeper the hearth should be to protect the floor.
- 3.2 The building must have a suitable load-bearing capacity for the hearth and appliance. Consult a structural engineer for advice before proceeding.
- 3.3 When fitting into an existing hearth check that the appliance complies with current construction regulations and is at least the minimum sizes shown.
- 3.4 If there is no existing fireplace or chimney it is possible to construct a suitable non-combustible housing and hearth setting. The flue must be installed in accordance with all local and national regulations and current rules in force.
- 3.5 Check if adding a new chimney to your property requires planning permission.
- 3.6 Some houses are built using a timber frame construction with high levels of thermal insulation. Isolate the appliance from combustible materials, and provide sufficient ventilation to maintain the heating efficiency.

Technical Appendix

4. Fitting Appliances On A Boat

- 4.1 If an appliance is to be fitted in a boat it must be done in accordance with the latest edition of BS 8511 (Code of Practice for the Installation of Solid Fuel Heating Appliances on Boats). The Code covers the design, installation and operation of solid fuel heating appliances that are suitable for fitting into inland waterway boats, and gives guidance on product selection, design considerations, installation requirements, inspection and testing, as well as maintenance and safe use tips.
- 4.2 Consideration should also be given to the requirements of the Boat Safety Scheme (BSS) to ensure the boat's insurance remains valid.
- 4.3 The appliance should only be installed by a competent person with experience of the latest edition of BS 8511 and the Boat Safety Scheme (BSS).
- 4.4 Secure the product to a suitably constructed non-combustible hearth.
- 4.5 All open flued appliances can be affected by temporary atmospheric conditions which may allow fumes to enter the boat. An electronic carbon monoxide detector conforming to the latest edition of BSEN50292 must be fitted and maintained.
- 4.6 Failure to safely install the appliance could endanger the boat and persons on board.



Organisations authorised to certify competence in the installation of domestic solid fuel appliances (Competent Persons Scheme):

APHC - Association of Plumbing and Heating Contractors (Certification) Ltd.
www.aphc.co.uk

BESCA - Building Engineering Services Competence Accreditation Ltd.
www.besca.org.uk

HETAS - Heating Equipment Testing and Approval Scheme Ltd.
www.hetas.co.uk

NAPIT - National Association of Professional Inspectors and Testers Ltd.
www.napit.org.uk

NICEIC - NICEIC Group Ltd.
www.niceic.org.uk

HETAS Approved Chimney Sweeps:

NACS - The National Association of Chimney Sweeps
www.chimneyworks.co.uk

APICS - The Association of Master Chimney Sweeps Ltd.
www.apics.org

The Guild of Master Chimney Sweeps -
guildofmasterchimneysweeps.co.uk

Basic Spare Parts

CL5 MIDLINE & HIGHLINE

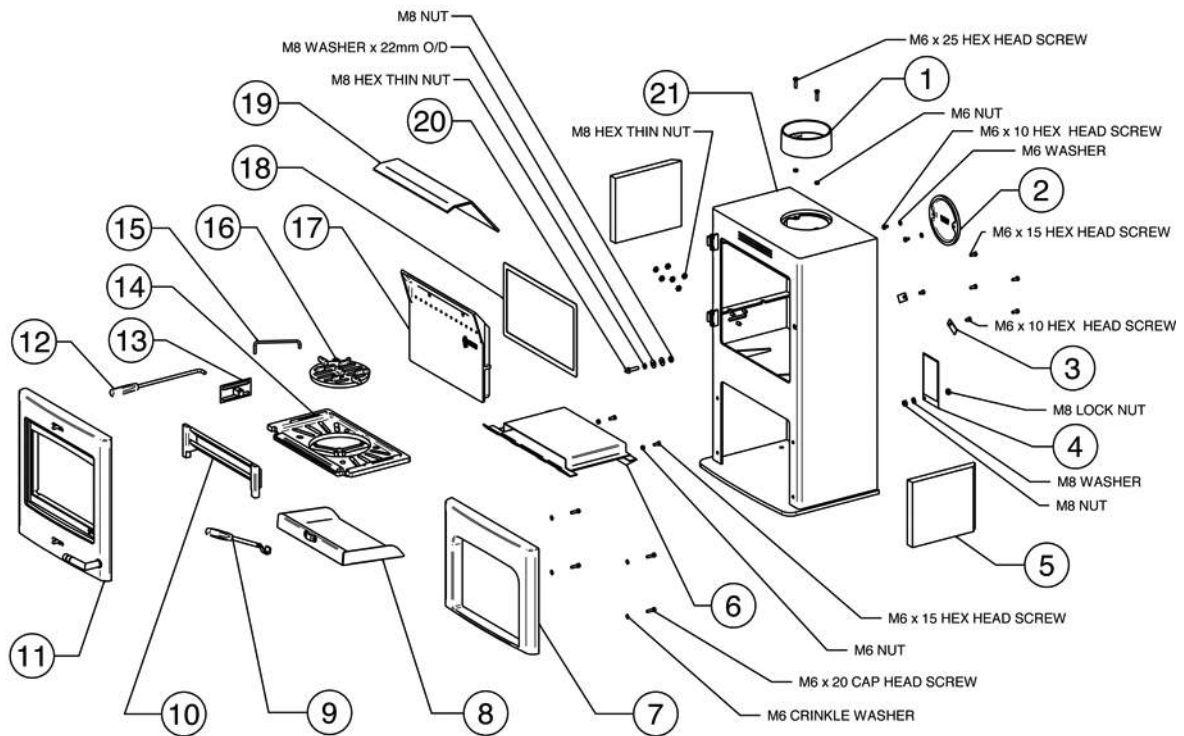

YM-CL5HLMF1 / YM-CL5MIDMF1

PR9551

MIDLINE

Ref No.	Description
1	5" CAST FLUE COLLAR
2	5" CAST FLUE BLANK
3	SECONDARY AIR COVER
4	DATA PLATE MOUNT
5	FIRE BRICK - MULTI-FUEL
6	HEAT SHIELD (LOG STORE)
7	MIDLINE PLINTH
8	ASH PAN ASSEMBLY
9	ASH PAN TOOL ASSEMBLY
10	LOG GUARD
11	DOOR ASSEMBLY
12	RIDDLING/DOOR TOOL
13	RIDDLING SLIDER ASSEMBLY
14	MAIN GRATE
15	RIDDLING OPERATING ROD
16	CENTRE GRATE
17	CLEANBURN AIR DUCT CASTING
18	10 X 2 S/A FLAT BLACK 2m ROPE BLACK
19	BAFFLE
20	LATCH SCREW (CL)
21	MIDLINE CARCASS - MULTI-FUEL

HIGHLINE

Ref No.	Description
1	5" CAST FLUE COLLAR
2	5" CAST FLUE BLANK
3	SECONDARY AIR COVER
4	DATA PLATE MOUNT
5	FIRE BRICK - MULTI-FUEL
6	HEAT SHIELD (LOG STORE)
7	HIGHLINE PLINTH
8	ASH PAN ASSEMBLY
9	ASH PAN TOOL ASSEMBLY
10	LOG GUARD
11	DOOR ASSEMBLY
12	RIDDLING/DOOR TOOL
13	RIDDLING SLIDER ASSEMBLY
14	MAIN GRATE
15	RIDDLING OPERATING ROD
16	CENTRE GRATE
17	CLEANBURN AIR DUCT CASTING
18	10 X 2 S/A FLAT BLACK 2m ROPE BLACK
19	BAFFLE
20	LATCH SCREW (CL)
21	HIGHLINE CARCASS - MULTI-FUEL

Due to continual technical improvements please check online at www.yeomanstoves.co.uk for the most up to date parts lists.

Basic Spare Parts

DOOR ASSEMBLY

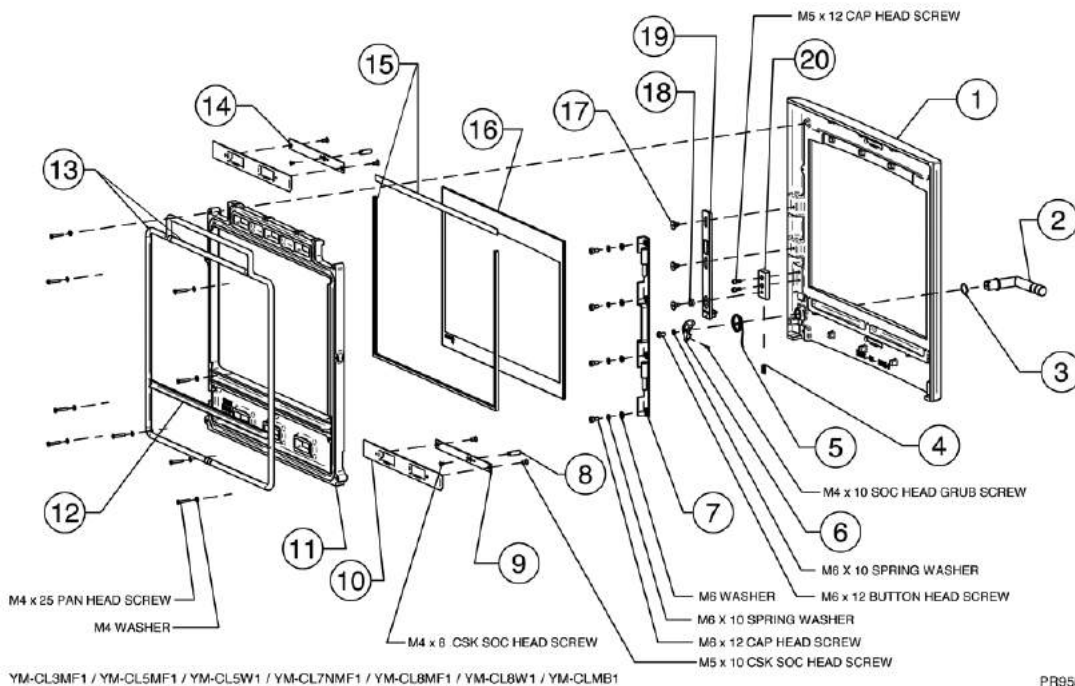

Ref No.	Description
1	CAST DOOR
2	DOOR HANDLE ASSEMBLY
3	WAVE SPRING - YRW-0087S17
4	SPRING 6.1 O/D X 0.61 DIA WIRE X 22.2 LG
5	TORSION SPRING
6	DOOR HANDLE CAM
7	HINGE PLATE ASSEMBLY
8	AIR CONTROL HANDLE
9	PRIMARY AIR SLIDER PLATE
10	AIR SLIDER
11	GLASS CLAMP
12	N/A
13	DOOR ROPE SEAL PACK
14	AIRWASH SLIDER PLATE
15	GLASS ROPE SEAL ROPE
16	DOOR GLASS
17	LARGE SHOULDER SCREW
18	DOOR CATCH SLIDER ROLLER
19	DOOR CATCH SLIDER
20	DOOR CATCH BLOCK

PR9554

Service Records

1ST SERVICE

Date of Service:.....

Next Service Due:.....

Signed:.....

Retailer's Stamp/HETAS Registration Number

2ND SERVICE

Date of Service:.....

Next Service Due:.....

Signed:.....

Retailer's Stamp/HETAS Registration Number

3RD SERVICE

Date of Service:.....

Next Service Due:.....

Signed:.....

Retailer's Stamp/HETAS Registration Number

4TH SERVICE

Date of Service:.....

Next Service Due:.....

Signed:.....

Retailer's Stamp/HETAS Registration Number

5TH SERVICE

Date of Service:.....

Next Service Due:.....

Signed:.....

Retailer's Stamp/HETAS Registration Number

6TH SERVICE

Date of Service:.....

Next Service Due:.....

Signed:.....

Retailer's Stamp/HETAS Registration Number

7TH SERVICE

Date of Service:.....

Next Service Due:.....

Signed:.....

Retailer's Stamp/HETAS Registration Number

8TH SERVICE

Date of Service:.....

Next Service Due:.....

Signed:.....

Retailer's Stamp/HETAS Registration Number

9TH SERVICE

Date of Service:.....

Next Service Due:.....

Signed:.....

Retailer's Stamp/HETAS Registration Number

10TH SERVICE

Date of Service:.....

Next Service Due:.....

Signed:.....

Retailer's Stamp/HETAS Registration Number



HETAS Approval

These appliances have been approved by HETAS as an intermittent operating appliance for burning manufactured briquette smokeless fuels.



A division of Stovax

Stovax Ltd, Falcon Road, Sowton Industrial Estate, Exeter, Devon, England EX2 7LF
Tel: (01392) 474011 Fax: (01392) 219932 E-mail: info@stovax.com www.stovax.com

E & O E