



# Yeoman CL Range

Conventional Flue Log Effect Stove

With Upgradeable Control Valve



## Instructions for Use, Installation and Servicing

For use in GB, IE (Great Britain and Republic of Ireland)

### **IMPORTANT**

**THE OUTER CASING, FRONT AND GLASS PANEL BECOME EXTREMELY HOT DURING OPERATION AND WILL RESULT IN SERIOUS INJURY AND BURNS IF TOUCHED. IT IS THEREFORE RECOMMENDED THAT A FIREGUARD COMPLYING WITH BS 8423:2002 IS USED IN THE PRESENCE OF YOUNG CHILDREN, THE ELDERLY OR INFIRM.**

This product contains a Heat resistant glass panel. This panel should be checked during Installation and at each servicing interval. If any damage is observed on the front face of the glass panel (scratches, scores, cracks or other surface defects), the glass panel must be replaced and the appliance must not be used until a replacement is installed. Under no circumstances should the appliance be used if any damage is observed, the glass panel is removed or broken.

It is essential that ALL of the screws that retain the glass frame are replaced and tightened correctly. Under no circumstances should the appliance be operated if any of these screws are loose or missing.

These Instructions must be left with the appliance for future reference and for consultation when servicing the appliance. Please make the customer aware of the correct operation of the appliance before leaving these instructions with them.

The commissioning sheet found on Page 3 of this Instruction manual must be completed by the Installer prior to leaving the premises.

# Contents

## Yeoman CL Range - Conventional Flue

Covering the following models:

Model	NATURAL GAS		LPG	
	Top Exit	Rear Exit	Top Exit	Rear Exit
CL3	YM581-016	YM581-003	YM581-427	YM581-409
CL5	YM581-090	YM581-059	YM581-484	YM581-460
CL8	YM581-141	YM581-126	YM581-588	YM581-567

**Appliance Commissioning Checklist .....3**

**User Instructions .....4**

**Installation Instructions .....12**

Technical Specifications ..... 12

Site Requirements ..... 14

Installation ..... 16

Commissioning .....25

**Servicing Instructions.....26**

Fault Finding.....26

How to replace parts .....28

Basic spare parts list .....38

Service Records .....44



If you have purchased your stove or fire from an authorised stockist within our Expert Retailer Network, then automatically your product will carry a 2 year warranty as standard. The 2 year warranty can be further extended to a total warranty period of 5 years by registering your Yeoman Stove or Fireplace within one month of the later of the purchase date or installation date. Accordingly, the start date for the warranty period is the date of purchase. During the registration process, the Expert Retailer details will be required for your Extended Warranty to be activated. Any product purchased outside of our Expert Retailer Network will carry a standard 12 month, non-extendable warranty.

It is a condition of the Extended Warranty that the installation complies with the relevant Building Regulations and is carried out by a suitably trained and qualified individual (GasSafe in the UK or equivalent in other countries) with the certificate of installation and the Commissioning Report on Page 3 completed and retained by the end user.

Full terms and conditions are detailed in the Warranty Statement on the Yeoman website [www.Yeomanstoves.co.uk](http://www.Yeomanstoves.co.uk). In the event of any conflict of information the wording on the website shall prevail.

Important Note: Should any problems be experienced with your product, claims must first be submitted to the Expert Retailer where the appliance was purchased from who will offer immediate assistance or contact Yeoman on your behalf.



**It is a requirement of the Building Regulations 2010 that the installation of this appliance is notified to the Local Authority. It is the responsibility of the GasSafe registered installer to carry out this notification to the Local Authority via the GasSafe register Competent Persons Scheme in England and Wales (different rules apply in Scotland and Northern Ireland).**

**When the installation has been notified, GasSafe will send a Building Regulations Compliance Certificate to you containing details of the work completed. Please ensure that the person responsible for the installation of this appliance completes this notification and records it in the Appliance Commissioning Checklist on page 3.**

**IT IS YOUR RESPONSIBILITY TO COMPLY WITH THE BUILDING REGULATIONS AND BE ABLE TO PRODUCE THIS CERTIFICATE SHOULD IT BE REQUIRED IN THE FUTURE.**

# Appliance Commissioning Checklist

To assist us in any guarantee claim please complete the following information:-

## IMPORTANT NOTICE

Explain the operation of the appliance to the end user, hand the completed instructions to them for safe keeping, as the information will be required when making any guaranteed claims.

FLUE CHECK	PASS	FAIL	
1. Flue Is correct for appliance			
2. Flue flow Test			
3. Spillage Test			
GAS CHECK			
1. Gas soundness & let by test			
2. Standing gas pressure	mb		
3. Appliance working pressure (on High Setting) NB All other gas appliances must be operating on full	mb		
4. Gas rate	m <sup>3</sup> /h		
5. Does Ventilation meet appliance requirements			
6. Have controls been upgraded (Upgradeable models only)	8455 Standard	YES	NO
	8456 Programmable Thermostatic and Timer	YES	NO
SAFETY CHECK			
1. Glass checked to ensure no damage, scratches, scores or cracks.			
2. Door secured correctly and all screws replaced			
BUILDING CONTROL NOTIFICATION	YES	NO	
1. Installer notified GasSafe/Local Authority of installation via Competent Persons Scheme?			

## RETAILER AND INSTALLER INFORMATION

<b>Retailer</b> .....	<b>Installation Company</b> .....
.....	.....
.....	.....
<b>Contact No.</b> .....	<b>Engineer</b> .....
<b>Date of Purchase</b> .....	<b>Contact No.</b> .....
<b>Model No.</b> .....	<b>Gas Safe Reg No.</b> .....
<b>Serial No.</b> .....	<b>Date of Installation</b> .....
<b>Gas Type</b> .....	

# User Instructions

## Welcome

*Congratulations on purchasing your CL stove, if installed correctly Yeoman hope it will give you many years of warmth and pleasure for which it was designed.*

*The purpose of this manual is to familiarise you with your appliance, and give guidelines for its installation, operation and maintenance. If, after reading, you need further information, please do not hesitate to contact your Yeoman retailer.*

## WARNING



**In the event of a gas escape or if you can smell gas, please take the following steps:**

- **Immediately turn off the gas supply at the meter/emergency control valve**
- **Extinguish all sources of ignition**
- **Do not smoke**
- **Do not operate any electrical light or power switches (On or Off)**
- **Ventilate the building(s) by opening doors and windows**
- **Ensure access to the premises can be made**

**Please report the incident immediately to the National Gas Emergency Service Call Centre on 0800 111 999 (England, Scotland and Wales) , 0800 002 001 (N. Ireland) or in the case of LPG, the gas supplier whose details can be found on the bulk storage vessel or cylinder.**

**The gas supply must not be used until remedial action has been taken to correct the defect and the installation has been recommissioned by a competent person.**

## 1. General

- 1.1 Installation and servicing must only be carried out by a competent person whose name appears on the Gas Safe register. To ensure the engineer is registered with Gas Safe they should possess an ID Card carrying the following logo:



- 1.2 In all correspondence, please quote the appliance type and serial number, which can be found on the data badge. The databadge is located on a chain behind the lower plinth.
- 1.3 **Do not** place curtains above the appliance: You must have 300mm (1') clearance between the appliance and any curtains at either side.

- 1.4 No furnishings or other objects should be placed within 1 metre of the front of the appliance.
- 1.5 If a shelf is fitted, a distance of 225mm above the appliance is required.
- 1.6 If any cracks appear in the glass panel do not use the appliance until the panel has been replaced.
- 1.7 This product is guaranteed for 5 years from the date of installation, as set out in the terms and conditions of sale between Yeoman and your local Yeoman Retailer. Please consult with your local Yeoman Retailer if you have any questions. In all correspondence always quote the Model Number and Serial Number.

## 2. Operating the Appliance

The control valve is located behind the plinth.

- 2.1 Remove the plinth to access the controls by lifting the hooks clear of the slots on the front of the appliance, see Diagram 1.

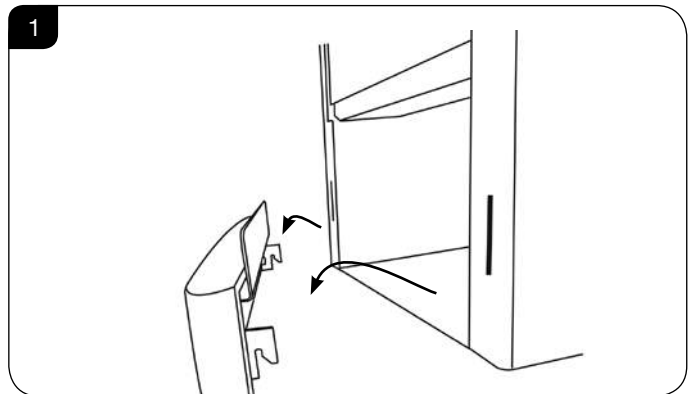

The valve has two controls, see Diagram 2.

1. The right-hand knob controls the pilot ignition.
2. The left-hand knob controls the main burner.

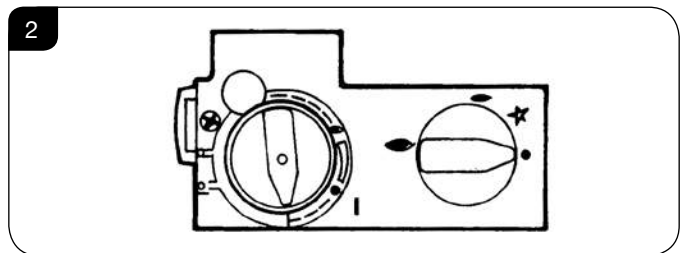

- 2.2 Refer to separate instructions if your appliance is upgraded to include battery remote control. The instructions below apply whether or not you have the remote upgrade.

# User Instructions

## Lighting the Pilot

- 2.3 To start the left-hand and right-hand control knobs must both point to off (●):
- 2.4 Press in the right-hand control knob and rotate anti-clockwise until a click is heard. Continue to press in. The knob points to the pilot (←).

The pilot is lit.

- 2.5 Keep the knob depressed for 10 seconds before releasing. The pilot remains lit.

Repeat the above steps if the pilot does not stay lit.

**NOTE: If the pilot goes out, the Interlock system prevents you lighting again for a short period.**

- 2.6 If, after repeating the above steps the pilot does not light, contact your Retailer or Installer.
- 2.7 Turn the right-hand knob to the left to main burner setting (↶).

## Adjusting the Flame height

- 2.8 You can now adjust the flame height and temperature using the left-hand control knob.
- 2.9 Turn the left-hand knob anti-clockwise to increase the flame height.
- 2.10 Turn clockwise to decrease the height.

**i** **IMPORTANT: YELLOW FLAMES TYPICALLY APPEAR WHEN THE APPLIANCE HAS REACHED NORMAL OPERATING TEMPERATURE. THIS CAN TAKE UP TO 30 MINUTES.**

**!** **WARNING: IF THE APPLIANCE FAILS TO LIGHT OR BECOMES EXTINGUISHED IN USE, WAIT 3 MINUTES BEFORE ATTEMPTING TO RELIGHT.**

## 3. Turning OFF the Appliance

- 3.1 To turn the main burner off turn the left-hand knob until it points to off (●). Just the pilot remains lit.
- 3.2 Press in and turn the right-hand knob until it points to off (●). The pilot goes out.

## 4. Upgrading the Appliance

- 4.1 The appliance is fitted with a control valve that can easily be upgraded to battery powered remote control. There are two versions of this control which can be obtained through your local Yeoman stockist. There is no requirement for this upgrade to be carried out by an approved Gas engineer. However Yeoman recommend that this task is undertaken by a suitably competent person.
- 4.2 This upgrade can be fitted before or after installation but if side clearances are limited then it will be easier to upgrade the appliance before installation. Full instructions are included with the kit.

## Standard Remote Control (PART NUMBER 8455)

- 4.3 This remote control can control the gas appliance after the pilot has been lit. It can turn the main burner on and regulate it from low through to high and back again. It can turn the main burner off leaving the pilot burning.

## Thermostatic and Timer Remote Control (PART NUMBER 8456)

- 4.4 This remote control can control the gas appliance after the pilot has been lit.

### MANUAL MODE

Can be used to turn the main burner on and manually regulate it from low through to high and back again. It can also be used to turn the main burner off leaving the pilot burning.

### AUTO MODE

Will automatically regulate the room to a pre-set temperature.

### TIMER MODE

Will turn the appliance on and off according to a pre-set programme and automatically regulate the room temperature during the two on periods.

## 5. Cleaning the Appliance

**!** **IMPORTANT: THE OUTER PANNELLING OF THE YEOMAN CL IS MADE FROM CAST IRON. USE CAUTION WHEN INSTALLING, REMOVING AND STORING AS THE COMPONENTS ARE HEAVY AND SHOULD BE HANDLED CAREFULLY.**

- 5.1 Make sure the fire and surrounds are cool before cleaning.
- Use:
- A dry cloth to clean the appliance casting.
  - A damp cloth for the glass front.

### All Models

- 5.2 Remove the plinth to access the controls by lifting the hooks clear of the slots on the front of the appliance, see Diagram 3.

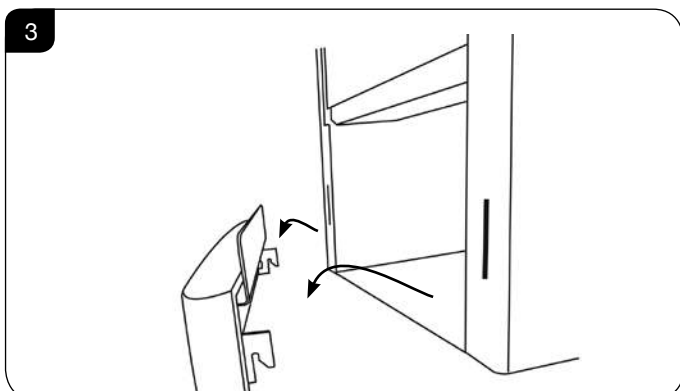

# User Instructions

- 5.3 Remove the frame to gain complete access to the control valve and the viewing aperture by lifting the hooks clear of the slots on the front of the appliance, see Diagram 4.

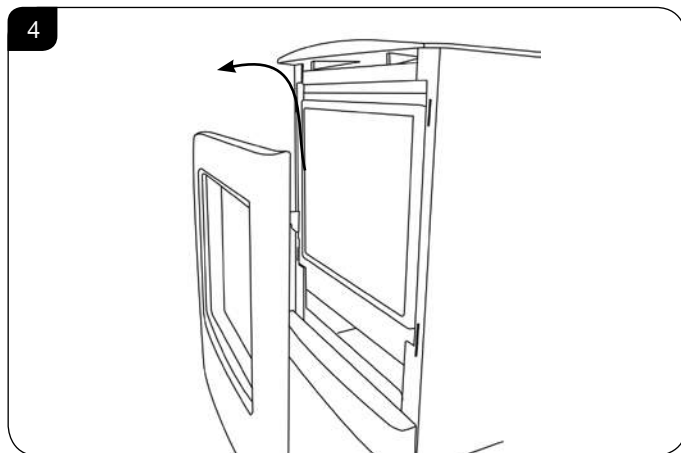

- 5.4 **CL3 and CL5 only:**

Using screwdriver remove the 6 screws securing the window panel to the appliance, see Diagram 5, Arrows A. Take care to support the glass when removing the screws.

- 5.5 **CL8 only:**

Using screwdriver remove the 8 screws, securing the window panel to the appliance, see Diagram 5, Arrows A & B. Take care to support the glass when removing the screws.

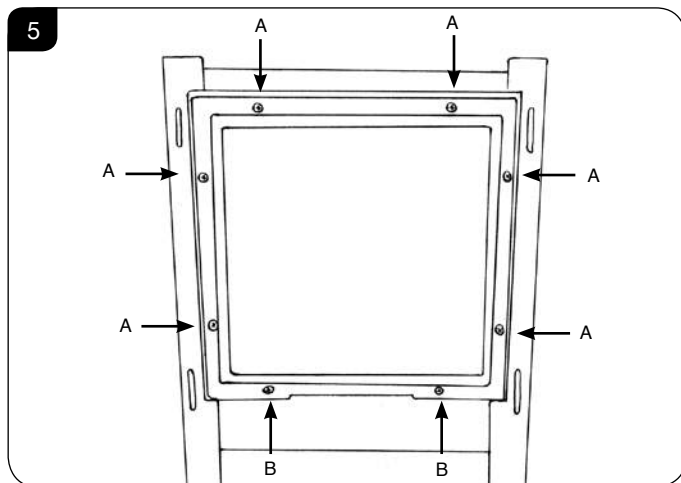

- 5.6 The glass frame must be refitted to the appliance following cleaning or servicing. Hold in position and secure with the screws.
- 5.7 Replace ALL of the securing screws ensuring that a screw is present in all fixing slots.

**! UNDER NO CIRCUMSTANCES SHOULD THE APPLIANCE BE USED IF ANY OF THE GLASS FRAME RETAINING SCREWS ARE LOOSE OR MISSING.**

## 6. Arrangement of Fuel Bed

### Advice on handling and disposal of fire ceramics



The fuel effect of the log version of this appliance is made from Refractory Ceramic Fibre (RCF), a material which is commonly used for this application.

Protective clothing is not required when handling these articles, but we recommend you follow normal hygiene rules of not smoking, eating or drinking in the work area and always wash your hands before eating or drinking.

To ensure that the release of RCF fibres are kept to a minimum, during installation and servicing a HEPA filtered vacuum is recommended to remove any dust accumulated in and around the appliance before and after working on it. When servicing the appliance it is recommended that the replaced items are not broken up, but are sealed within heavy duty polythene bags and labelled as RCF waste.

RCF waste is classed as stable, non-reactive hazardous waste and may be disposed of at a licensed landfill site.

Excessive exposure to these materials may cause temporary irritation to eyes, skin and respiratory tract; wash hands thoroughly after handling the material.



# User Instructions

## 7. Log Layout

**LOGS MUST BE POSITIONED ACCORDING TO THE FOLLOWING INSTRUCTIONS TO GIVE THE CORRECT FLAME EFFECT**

### CL3 Layout

All logs can be identified by a letter (A - E) on their underside. Logs B and E also have holes to locate each onto a burner stud.

- 7.1 Ensure the burner tray is clean and free from any debris, see Diagram 6.



- 7.2 Place Log A on the higher rear bracket and push up against the back panel, see Diagram 7.

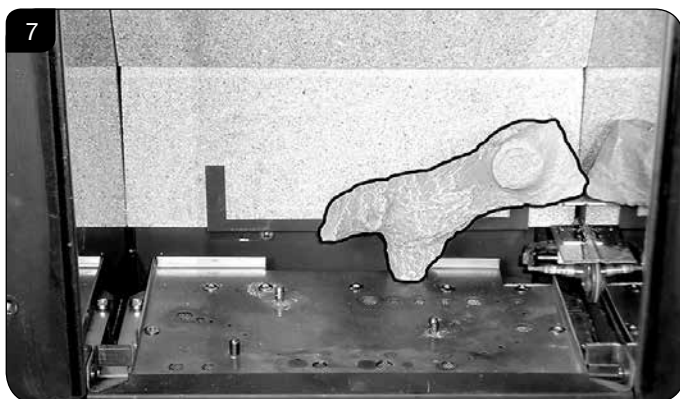

- 7.3 Place Log B over the two middle studs on the burner tray, see Diagram 8.

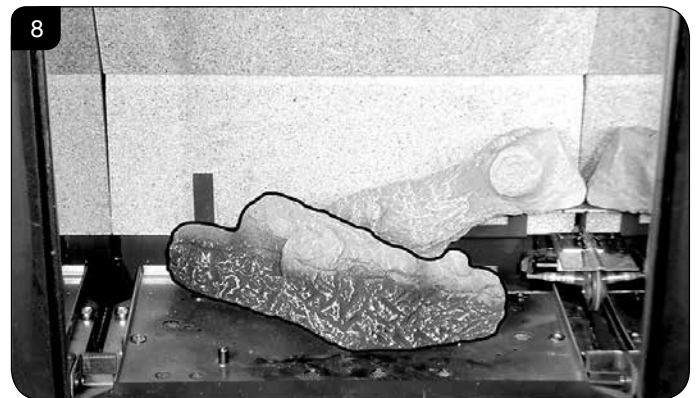

- 7.4 Place Log E onto the stud and behind the tag on the left hand side of the burner tray. Rest against Log B, see Diagram 9.

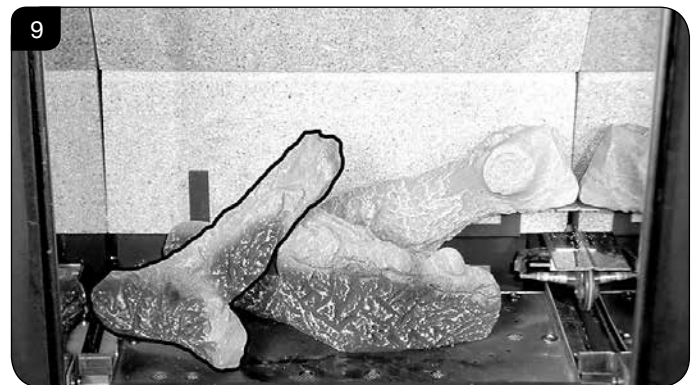

- 7.5 Place the small Ember at the front left of the firebox against the rear of the log support bracket to obscure the reflection of the burner screw.

Place the larger Ember on the lower bracket above the pilot on the right hand side with the thicker edge facing the front and flat edges to the base and side, see Diagram 10.

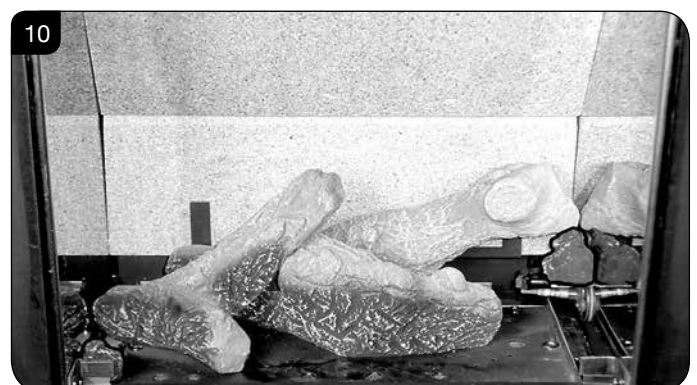

# User Instructions

- 7.6 Log C rests on the cutout on Log E and is pushed up to the side and rear of the firebox, see Diagram 11.



- 7.7 Place the pointed bottom of log D into the corner of the burner tray and rest on the location stud in log B, see Diagram 12.



- 7.8 Use some of the Embaglow provided and cover the ports in the burner tray with a liberal amount of fibres. Use a small piece in front of the log on the left hand side and a long strip in front of log B, see Diagram 13.

NOTE: It is not necessary to use all of the Embaglow.



- 7.9 Lower log guard into position, see Diagram 14.



## CL5 Layout

- 7.10 Ensure the burner tray is clean and free from any debris, see Diagram 15.

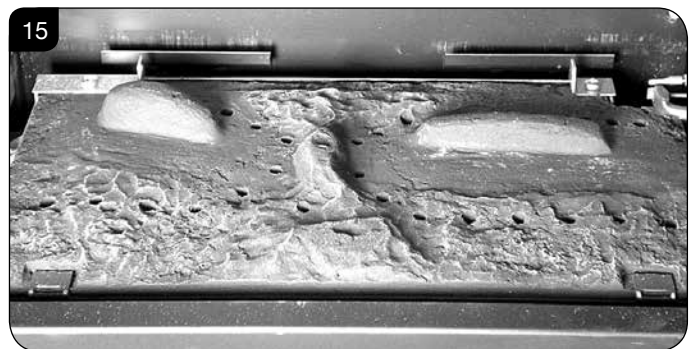

The three logs that make up the fuel bed are visually distinct and fit into specific parts on the burner tray.

- 7.11 Place the rear log into position between the rear brackets and pushed up against the back panel, see Diagram 16.

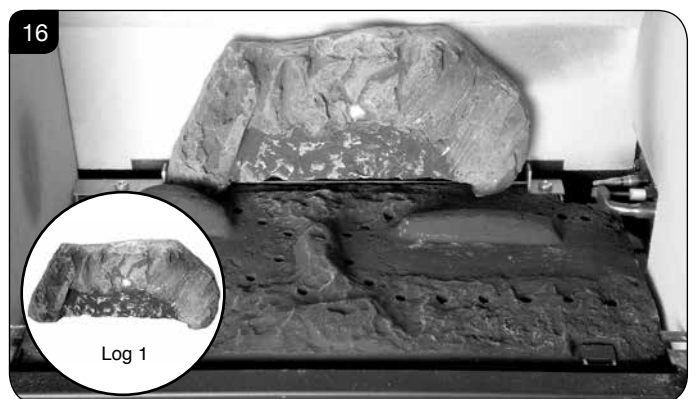



# User Instructions

- 7.12 Place the second log into the left hand groove on the burner tray, see Diagram 17.  
The log should butt up against the raised molding and the left hand side liner.

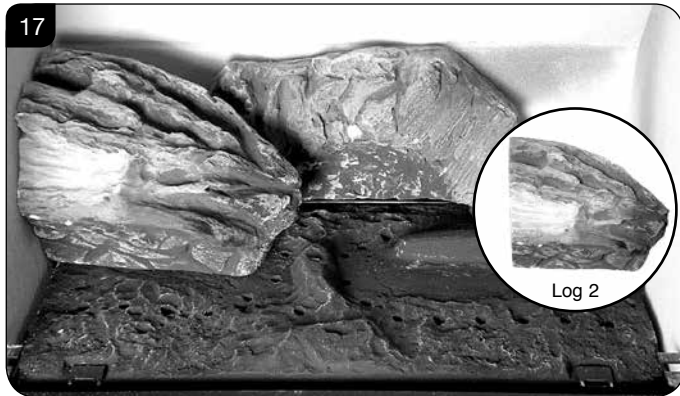

- 7.13 Place the third log into the groove on the right hand side, see Diagram 18.  
The log should butt up against the raised molding and the right hand side liner.

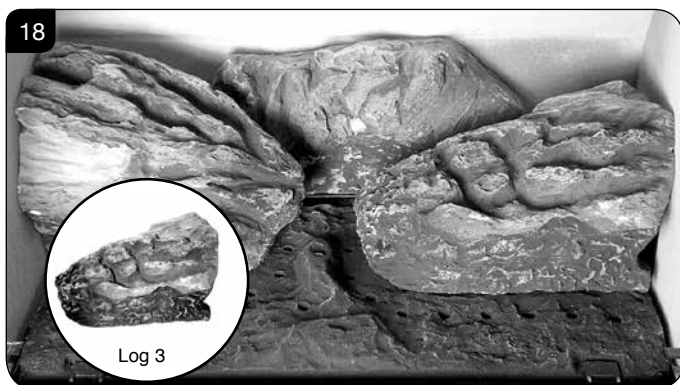

- 7.14 Once the logs are in there are two embers which can be loosely placed at the front of the fuel bed and cover the tabs securing the burner tray, see Diagram 19.

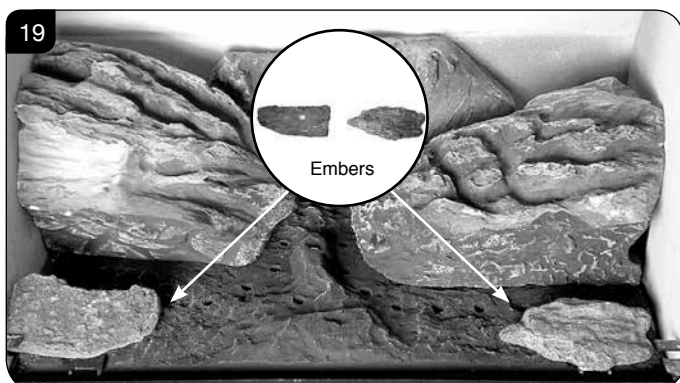

- 7.15 Use some of the Embaglow provided and cover the ports in the burner tray with a liberal amount of fibres, see Diagram 20.

**It is essential to cover the port in the middle of the burner tray in order to get the most visually appealing flame picture.**

NOTE: It is not necessary to use all of the Embaglow.

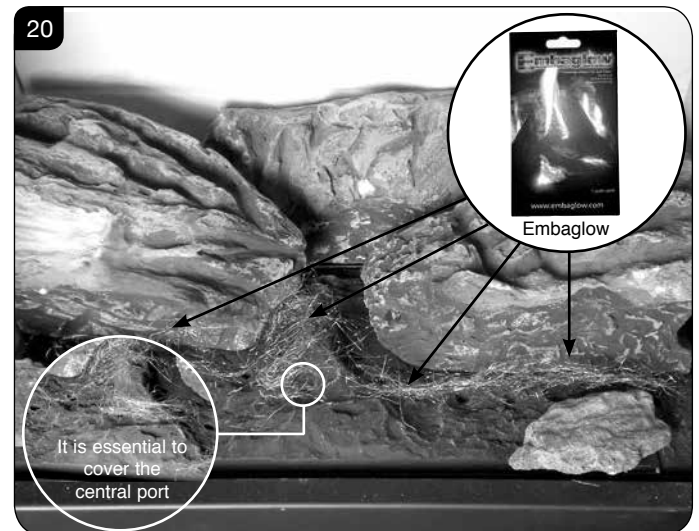

- 7.16 Fix log guard into position, see Diagram 21.

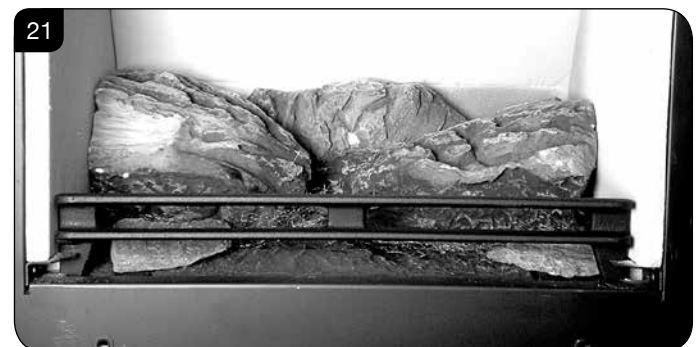

## CL8 Layout

The logs for the fuel bed are clearly individually labelled, A to D.

- 7.17 Ensure the burner tray is clean and free from any debris, see Diagram 22.

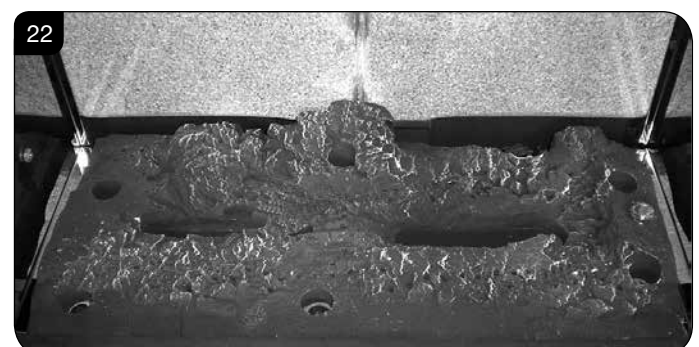

# User Instructions

- 7.18 There are 3 embers. Place 2 embers in the back corners of the burner, resting in the cut outs, see Diagram 23. Place the last ember loosely at the front of the fuel bed to cover the hole in the centre.

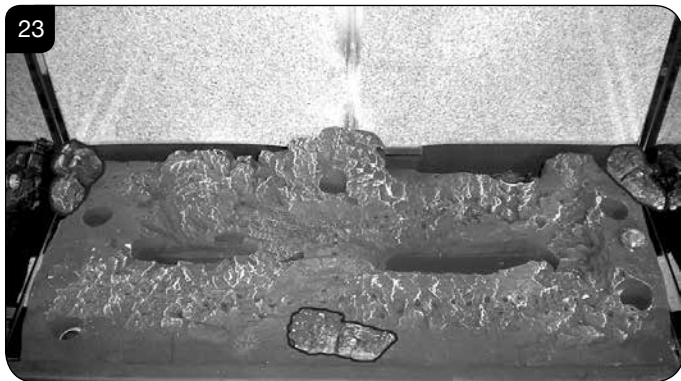

- 7.19 Place Log D on the left hand side of the burner. There is a hole on the underside of Log D which fits over the raised stud on the left of the burner. The back of the log should rest flat against the back panel, see Diagram 24.

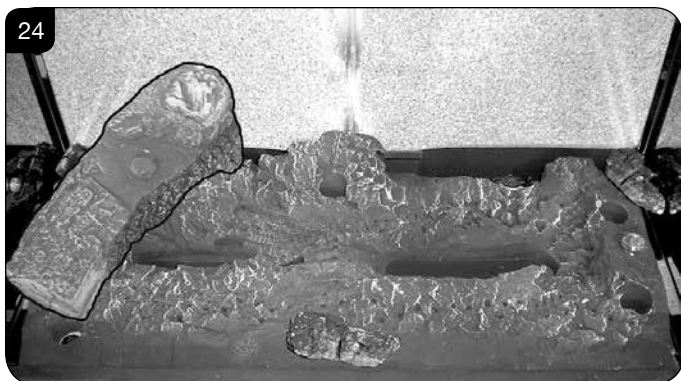

- 7.20 Place Log B on top of Log D. There is a hole on the underside of Log B which fits over the raised stud on Log D to secure in place. The right hand side of the log rests in the groove in the burner, see Diagram 25.

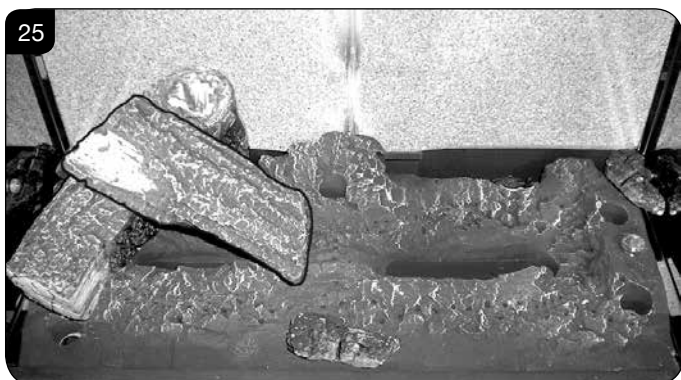

- 7.21 Place Log C on the right hand side of the burner. There is a hole on the underside of Log C which fits over the raised stud on the right of the burner. The back of the log should rest flush against the back panel, see Diagram 26.



- 7.22 Place the log guard into position on the grooves on the sides of the firebox, see Diagram 27.

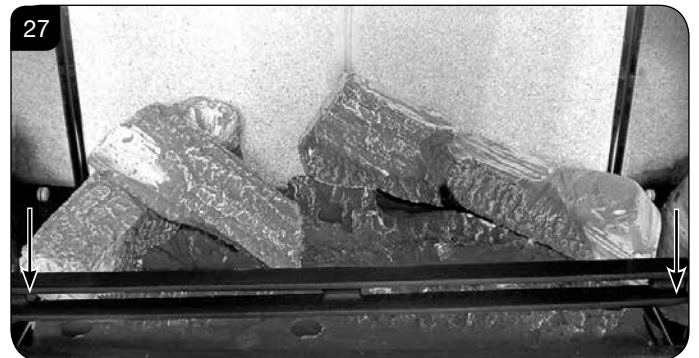

- 7.23 Place Log A across Log C. There is a hole on the underside of Log A which fits over the raised stud on Log C to secure in place. The small cut out on the left side of the log rests onto the log guard, see Diagram 28.



# User Instructions

7.24 Once the logs are in place use some of the Embaglow wire wool provided and cover the ports in the burner tray with a liberal amount of fibres, in the highlighted areas shown in Diagram 29.

NOTE: It is not necessary to use all of the Embaglow.  
**IT IS ESSENTIAL TO KEEP THE REAR PORT FREE FROM OBSTRUCTION.**



7.25 Use a ceramic glass product generally sold for cleaning ceramic hobs to clean the glass front.

The glass frame must be refitted to the appliance following cleaning or servicing.

## 8. Flame Failure Device

8.1 This is a safety feature incorporated on this appliance which automatically switches off the gas supply if the pilot goes out and fails to heat the thermocouple.

**IF THIS OCCURS DO NOT ATTEMPT TO RELIGHT THE APPLIANCE FOR 3 MINUTES.**

## 9. Running In

9.1 During initial use of a new YEOMAN appliance a strong odour will be encountered as various surface coatings become hot for the first time. Although these odours are harmless it is recommended that the appliance is operated on maximum for 4 to 8 hours in order to fully burn off these coatings. After this period the odours should then disappear.

If the odours persists, please contact your installer for advice.

9.2 During the first few hours of burning there may be discolouration of the flames. This will also disappear after a short period of use.

## 10. Servicing

10.1 The appliance must be serviced every 12 months by a qualified Gas Engineer. In all correspondence always quote the Model number and the Serial number which may be found on the Commissioning Checklist (Page 3).

## 11. Ventilation

11.1 Any purpose provided ventilation should be checked periodically to ensure that it is free from obstruction.

## 12. Installation Details

12.1 Your installer should have completed the commissioning sheet at the front of this book. This records the essential installation details of the appliance. In all correspondence always quote the Model number and Serial number.

## 13. Hot Surfaces

13.1 Parts of this appliance become hot during normal use.

13.2 Provide a suitable fire guard to protect young children and the infirm.

# Installation Instructions

## Technical Specification

Covering the following models:

Model	NATURAL GAS		LPG	
	Top Exit	Rear Exit	Top Exit	Rear Exit
CL3	YM581-016	YM581-003	YM581-427	YM581-409
CL5	YM581-090	YM581-059	YM581-484	YM581-460
CL8	YM581-141	YM581-126	YM581-588	YM581-567

Model	Gas CAT.	Gas Type	Working Pressure	Aeration	Injector	Gas Rate m <sup>3</sup> /h	Input kW (Gross)		Country
							High	Low	
CL3 CF	l <sub>2</sub> H	Natural (G20)	20mbar	1mm x 6mm Ø	185	0.314	3.3	2.0	GB, IE
	l <sub>3</sub> P	Propane (G31)	37mbar	6mm x 15mm	90	0.120	3.2	2.0	GB, IE
CL5 CF	l <sub>2</sub> H	Natural (G20)	20mbar	6mm x 6mm	260	0.433	4.55	2.5	GB, IE
	l <sub>3</sub> P	Propane (G31)	37mbar	16mm x 23mm 14mm x 15mm	102	0.164	4.35	2.5	GB, IE
CL8 CF	l <sub>2</sub> H	Natural (G20)	20mbar	2 x 6mm Ø	067	0.629	6.6	3.9	GB, IE
	l <sub>3</sub> P	Propane (G31)	37mbar	2 x 13mm Ø	128	0.252	6.7	3.7	GB, IE
<b>CL3 &amp; CL5 Efficiency Class 2 - 75% Net/ NOx Class 4</b>									
<b>CL8 Efficiency Class 2 - 78% Net/ NOx Class 4</b>									
Flue Size TOP/REAR EXIT 127mm ø									
Gas Inlet Connection Size = 8mm ø									
Minimum Flue Specification = T250/N2/O/D/1									
Maximum Flue Temp = 220°C									

**i** The net efficiency of this appliance has been measured as specified in EN613:2001 and the result after conversion to gross using the appropriate factor from Table E4 of SAP 2009 is 67.6% for the CL3 & CL5 and 70.3% for the CL8. The test data has been certified by Kiwa Nederand BV. The gross efficiency value may be used in the UK Government's Standard Assessment Procedure (SAP) for energy rating of dwellings.

# Installation Instructions

## Technical Specification

This appliance has been certified for use in countries other than those stated. To install this appliance in these countries, it is essential to obtain the translated instructions and in some cases the appliance will require modification. Contact Yeoman for further information.

### PACKING CHECKLIST

Qty Description	Fixing Kit containing:-
For Log Layout	1 x Instruction Manual
1 Log Set	2 x Wood Screws
1 x Packet of Embaglow	2 x Rawl Plugs
	2 x Self Tapping Screws
	2 x Wingnuts
	1 x Fixing Plate
	2 x Washers

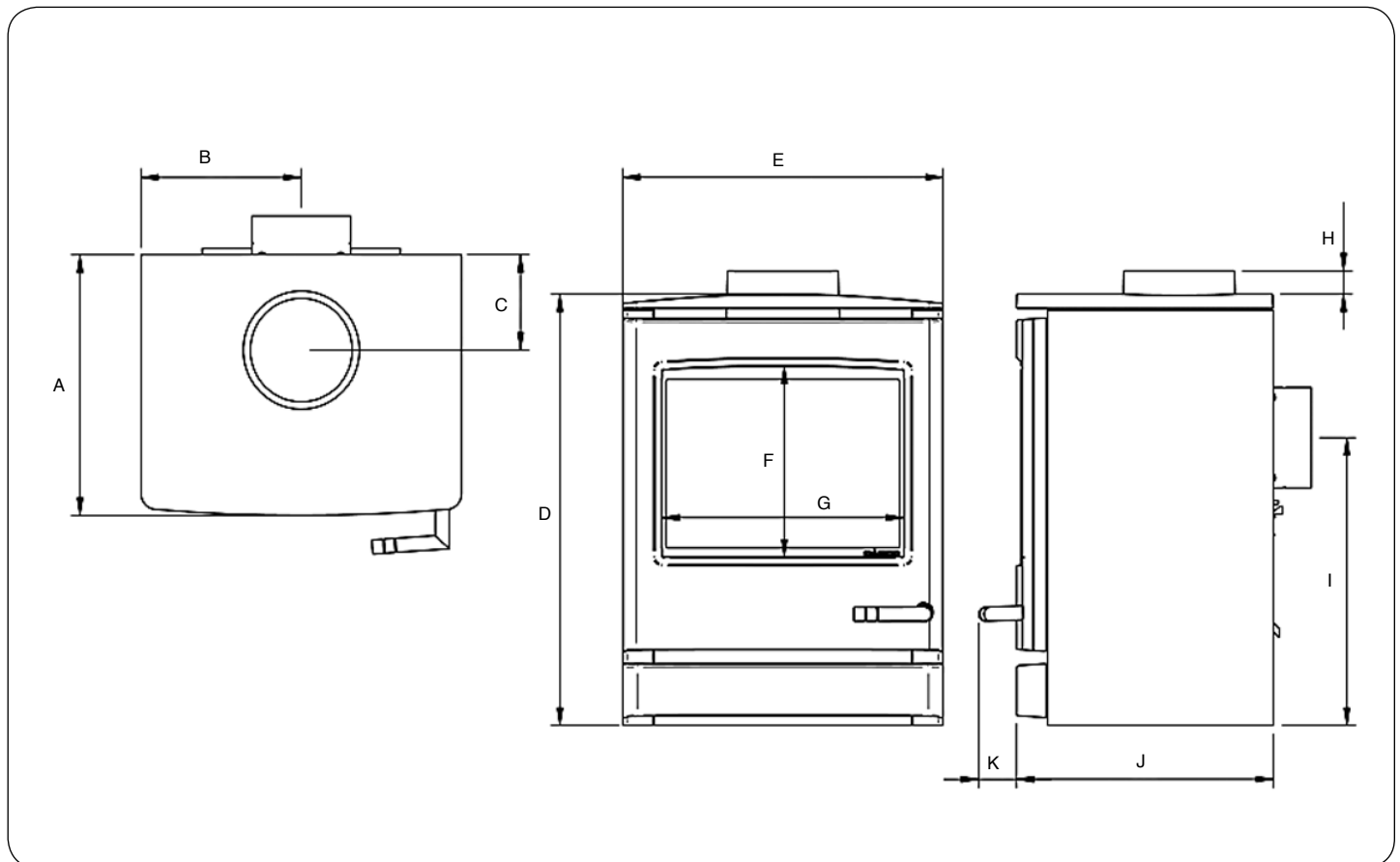

Model	A	B	C	D	E	F	G	H	I	J	K
CL3	313	186	99	541	371	243	252	30	359	313	49
CL5	333	208	122	551	416	244	314	30	368	333	49
CL8	365	277	100	604	553	274	427	52	462	364	49

# Installation Instructions

## Site Requirements

### 1. Flue & Chimney Requirements

- 1.1 The chimney or flue system must comply with the rules in force, and must be a minimum of 127mm in diameter. (5").
- 1.2 The minimum flue height for the appliance must be 3 metres (10ft). Any horizontal flue run from the rear outlet must not exceed 100mm from the back of the appliance.
- 1.3 The chimney or flue must be free from any obstruction. Any damper plates must be removed or secured in the fully open position, and no restrictor plates fitted.
- 1.4 The chimney must be swept prior to the installation, but it need not be swept if it can be seen the chimney is clean and unobstructed throughout its entire length.
- 1.5 A 5" (127mm) liner must be used if fitting the appliance into an existing brick built chimney.  
Larger lined flues can work, but in some instances could cause cold start flue problems resulting in nuisance shutdown. Lined flues above 7" (175mm) are not recommended.
- 1.6 Due to European chimney standards, new flue's and chimney's are described by their temperature, pressure and resistance to corrosion, condensation and fire. To assist in identifying the correct flue system, the minimum flue specification is shown in the Technical Specification. Existing chimneys are not covered by this system.

### 2. Flue Options

- 2.1 Consult the rules in force.

NOTE: This appliance does not normally require any additional ventilation when installed in GB.

**A range of Vitreous Enamel Gloss Black flue pipe is available to compliment the appliance. Please contact your Yeoman retailer for further information.**

### 3. Gas Supply

**THIS APPLIANCE IS INTENDED FOR USE ON A GAS INSTALLATION WITH A GOVERNED METER.**

- 3.1 Before installation, ensure that the local distribution conditions (identification of the type of gas and pressure) and the adjustment of the appliance are compatible.
- 3.2 Ensure the gas supply delivers the required amount of gas and is in accordance with the rules in force.
- 3.3 You can use soft copper tubing on the installation and soft soldered joints outside the appliance and below the fire.
- 3.4 A factory fitted isolation device is part of the inlet connection; no further isolation device is required.

- 3.5 All supply gas pipes must be purged of any debris that may have entered prior to connection to the appliance.
- 3.6 The gas supply enters through the rear of the LEFT-HAND side of the outer box:
- 3.7 The gas supply must be installed in a way that does not restrict the removal of the appliance for servicing and inspection.

### 4. Ventilation

**IMPORTANT: Ensure any national ventilation requirements are taken into account during installation of the fire.**

**UK ONLY:**

The appliance has a nominal input not exceeding 7.0kW and does not normally require any additional permanent ventilation.

**FOR THE REPUBLIC OF IRELAND REFER TO THE RULES IN FORCE FOR VENTILATION REQUIREMENTS.**

### 5. Appliance Location

- 5.1 This appliance has been designed to stand on either a hearth or an optional bench:  
RVACLB100B - Riva Bench Low (100cm wide)  
RVACB100B - Riva Bench (100cm wide)  
RVACLB120B - Riva Bench Low (120cm wide)  
RVACB120B - Riva Bench (120cm wide)  
RVACLB140B - Riva Bench Low (140cm wide)  
RVACB140B - Riva Bench (140cm wide)
- 5.2 **To Install the Bench:**  
Follow Section 1 Installation - All Models in Installation guide PM205 supplied with the bench kit.
- 5.3 **To secure the appliance to the bench:**  
You must consider where you place the appliance on the bench before drilling the bench, see Diagram 1.

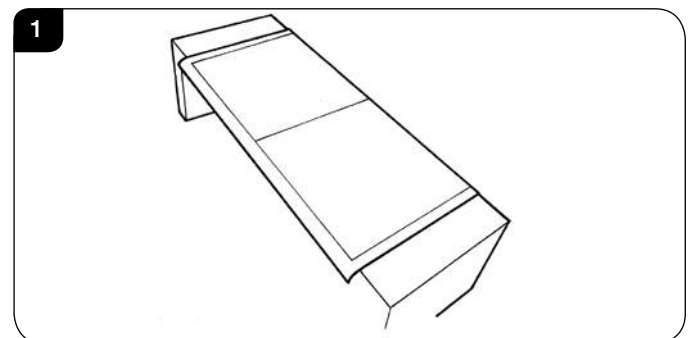

**Once the position of the appliance has been decided:**  
Follow the instructions for securing the appliance on Page 16.



# Installation Instructions

## Site Requirements

- 5.4 The non-combustible hearth must be at least 12mm thick, and project a minimum of 50mm from the base of the appliance in all directions.
- 5.5 The appliance is not suitable for installation against a combustible wall. A combustible side wall must be a minimum of 150mm from the appliance.
- 5.6 This appliance can be installed with an up and out flue (vertical wall - horizontal flue) or with a vertical flue with roof termination (see **Flue Options, Section 2 Site Requirements**).

### HEARTH INSTALLATION

- 5.7 Building Regulations state this appliance must stand on a non-combustible hearth that is at least 12mm thick and projects 50mm minimum from the base of the appliance in all directions, however Yeoman recommend the hearth extends to the following dimensions, see Diagram 2.

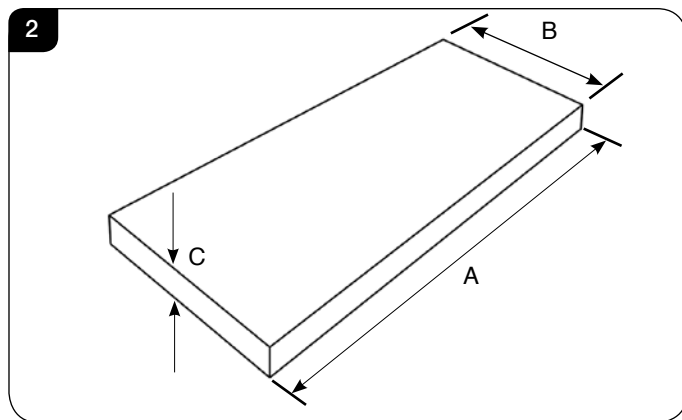

Dimensions	CL3	CL5	CL8
A	671mm	716mm	853mm
B	413mm	433mm	464mm
C	12mm	12mm	12mm

### MINIMUM CLEARANCE

- 5.8 The appliance is not suitable for installation against a combustible wall. All combustible materials must be removed from behind the appliance.

- 5.9 **Ensure that all minimum clearances to combustible materials are complied with as shown in Diagrams 3 & 4.**

The specified clearances provide the minimum distance to combustible materials. If the appliance is intended to be installed into a non-combustible opening the clearance to the **sides and above** the appliance can be reduced. However, it is recommended that the specified clearances are maintained irrespective of the materials used in the construction of the opening to allow adequate air flow and access to controls. **The clearance at the rear of the appliance must always be a minimum of 50mm.**

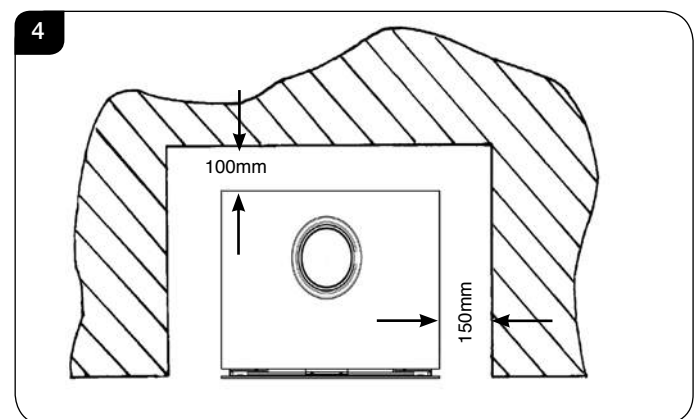
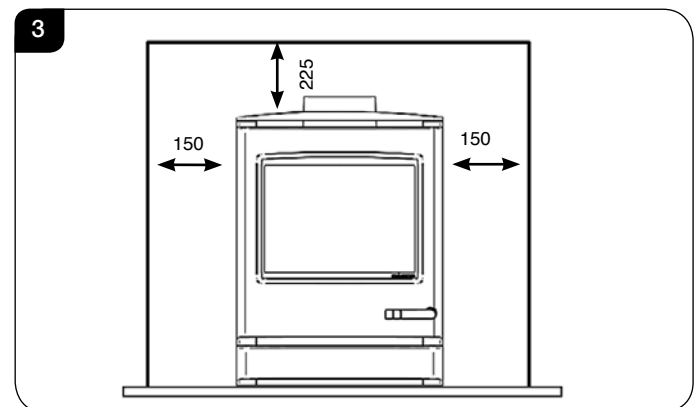

- 5.10 The above dimensions provide adequate clearance to combustible materials. It may be necessary to add additional clearance so that spillage tests can be performed when necessary.

# Installation Instructions

## 1. Safety Precautions

- 1.1 For your own and other's safety, you must install this appliance according to local and national codes of practice. Failure to install the appliance correctly could lead to prosecution. **Read these instructions before installing and using this appliance.**
- 1.2 These instructions must be left intact with the user.
- 1.3 Do not attempt to burn rubbish on this appliance.
- 1.4 Keep all plastic bags away from young children.
- 1.5 Do not place any object on or near to the appliance and allow adequate clearance above the appliance.

**IF THE APPLIANCE IS EXTINGUISHED OR GOES OUT IN USE, WAIT 3 MINUTES BEFORE ATTEMPTING TO RELIGHT THE APPLIANCE.**



**IMPORTANT: REFER TO DATA BADGE AND TECHNICAL SPECIFICATION AT THE FRONT OF THE MANUAL TO ENSURE THE APPLIANCE IS CORRECTLY ADJUSTED FOR THE GAS TYPE AND CATEGORY APPLICABLE IN THE COUNTRY OF USE.**

**FOR DETAILS OF CHANGING BETWEEN GAS TYPES REFER TO SERVICING, SECTION 16, REPLACING PARTS.**

## Unpacking

- 1.6 Remove the appliance from its packaging, and check that it is complete and undamaged.
- 1.7 The cast plate is stored on top of the appliance. Remove and store in a safe place.

Put the loose ceramic parts to one side so that they are not damaged during installation.

## 2. Upgrading the Appliance

- 2.1 The appliance is fitted with a control valve that can easily be upgraded to battery powered remote control. There are two versions of this control which can be obtained through your local Yeoman stockist. There is no requirement for this upgrade to be carried out by an approved Gas engineer. However Yeoman recommend that this task is undertaken by a suitably competent person.
- 2.2 This upgrade can be fitted before or after installation but if side clearances are limited then it will be easier to upgrade the appliance before installation. Full instructions are included with the kit.

## Standard Remote Control (PART NUMBER 8455)

- 2.3 This remote control can control the gas appliance after the pilot has been lit. It can turn the main burner on and regulate it from low through to high and back again. It can turn the main burner off leaving the pilot burning.

## Thermostatic and Timer Remote Control (PART NUMBER 8456)

- 2.4 This remote control can control the gas appliance after the pilot has been lit.

### MANUAL MODE

Can be used to turn the main burner on and manually regulate it from low through to high and back again. It can also be used to turn the main burner off leaving the pilot burning.

### AUTO MODE

Will automatically regulate the room to a pre-set temperature.

### TIMER MODE

Will turn the appliance on and off according to a pre-set programme and automatically regulate the room temperature during the two on periods.

# Installation Instructions

## 3. Installation of the Appliance



**IMPORTANT: THE OUTER PANELLING OF THE YEOMAN CL IS MADE FROM CAST IRON. USE CAUTION WHEN INSTALLING, REMOVING AND STORING AS THE COMPONENTS ARE HEAVY AND SHOULD BE HANDLED CAREFULLY.**

- 3.1 Remove the plinth to access the controls by lifting the hooks clear of the slots on the front of the appliance, see Diagram 1.

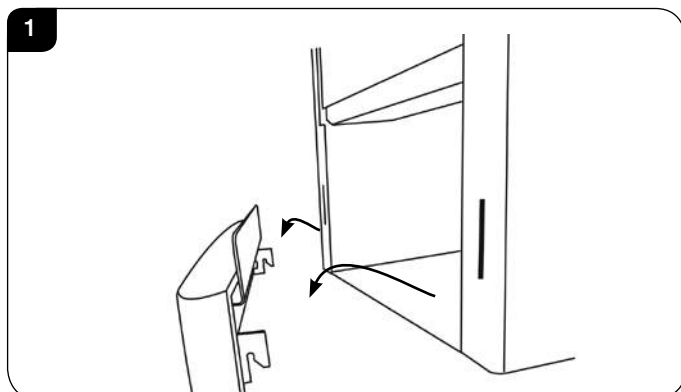

- 3.2 Remove the frame to gain complete access to the control valve and the viewing aperture by lifting the hooks clear of the slots on the front of the appliance, see Diagram 2.

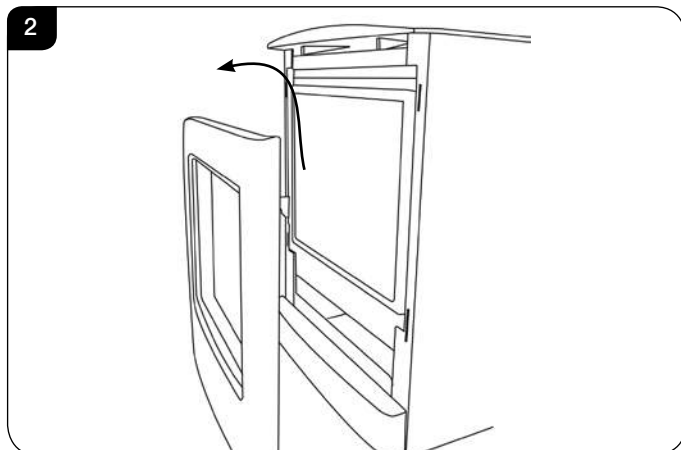

## CL3 & CL5 only

### SECURING THE APPLIANCE

The appliance sits on a mounting bracket to secure it in place to either the hearth or bench.

- 3.3 Position the appliance:  
Loosely attach the bracket to the appliance and place centrally on the hearth OR in the desired position on the bench. Remove the appliance leaving the bracket in the correct position and mark the holes to drill the bracket screws, see Diagram 3.

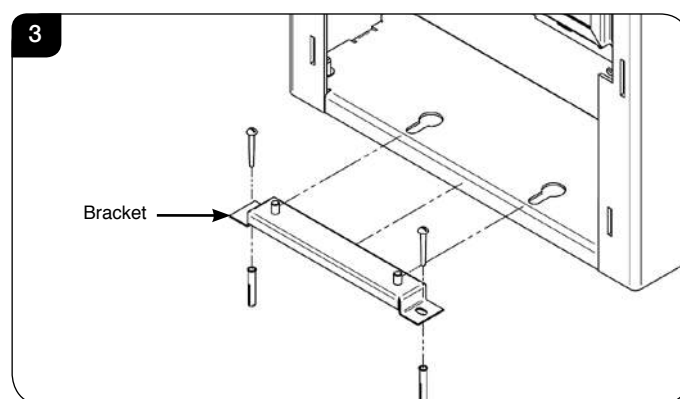

- 3.4 Remove the bracket and drill the guide holes.  
3.5 Fix the bracket either to the hearth or the bench, see Diagram 3.

**NOTE: Use the wood screws and rawl plugs in the fixing kit supplied for hearth mounting installations and the self tapping screws for installation onto a bench.**

- 3.6 Lift the appliance so as to locate the key slots in the carcass onto the fixing screws. There are two large holes the lower flanges on the front edges of the base, see Diagram 4.

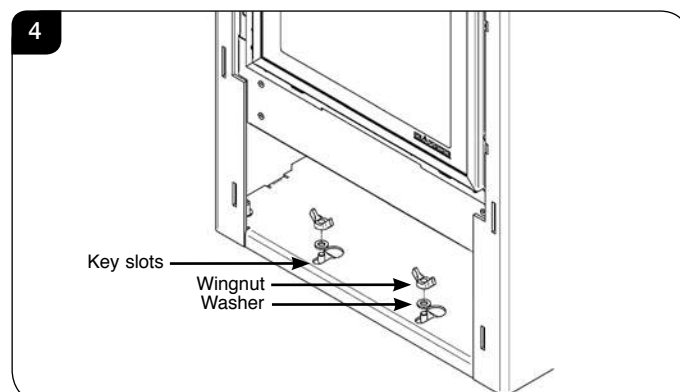

- 3.7 Place the two large washers over the studs and fix with two wingnuts, see Diagram 4.

# Installation Instructions

## 4. Fitting the Top Plate

- 4.1 The Yeoman CL has a cast plate that sits on top of the outer box. Depending on the choice of flue exit this top will have a hole for the flue pipe to pass through or be completely smooth.

The hole will be situated in an off set position to the rear edge of the cast top.  
When installing the spigot must be put in place before the cast top is located. Then the connection to the flue can be made.

**NOTE: For Top Exit appliances the flue collar must be placed on the flue exit before the top is fitted.**

- 4.2 To fit the top line up the raised fins on the underside of the cast plate with the cut outs in the top of the box, see Diagram 5a & 5b.

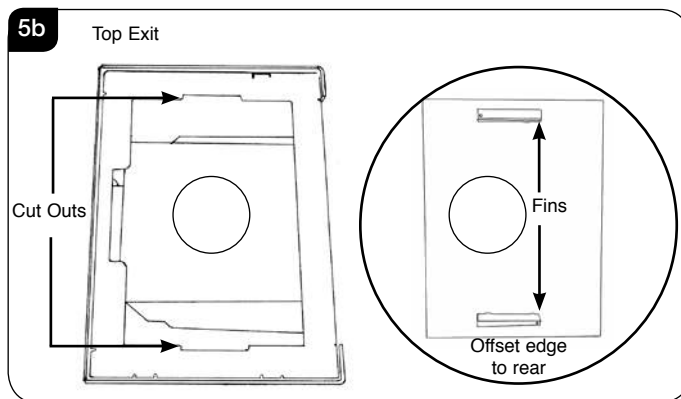
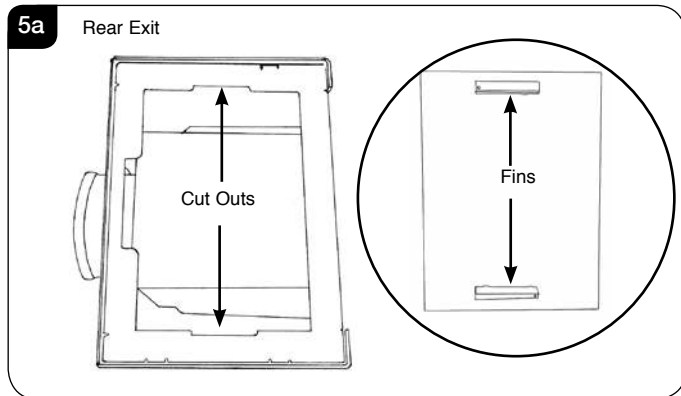

- 4.3 When properly fitted the rear of the cast plate should sit flush with the rear of the appliance, see Diagram 6.

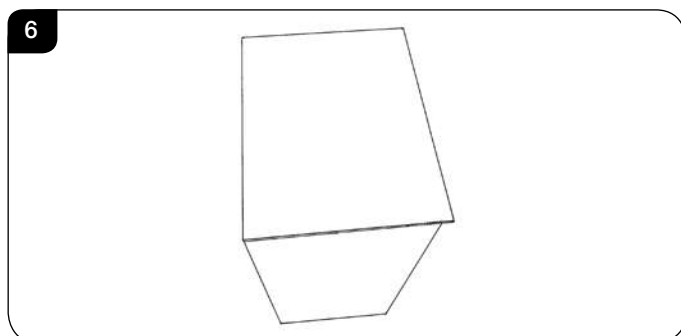

## 5. Gas Soundness Pressure Check

- 5.1 Connect a suitable pressure gauge to the test point located on the inlet fitting and turn the gas supply on. Light the appliance and check all gas joints for possible leaks. Turn the appliance to maximum and check that the supply pressure is as stated on the databadge. Turn the gas off and replace the test point screw, turn the gas on and check the test point for leaks.

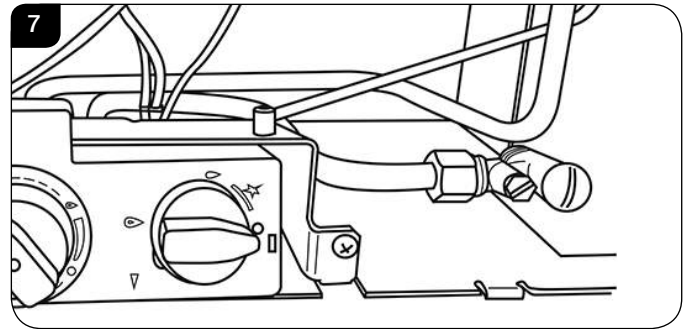

## 6. Removing the Glass

- 6.1 **CL3 and CL5 only:**

Using screwdriver remove the 6 screws securing the window panel to the appliance, see Diagram 8, Arrows A.

- 6.2 **CL8 only:**

Using screwdriver remove the 8 screws, securing the window panel to the appliance, see Diagram 8, Arrows A & B.

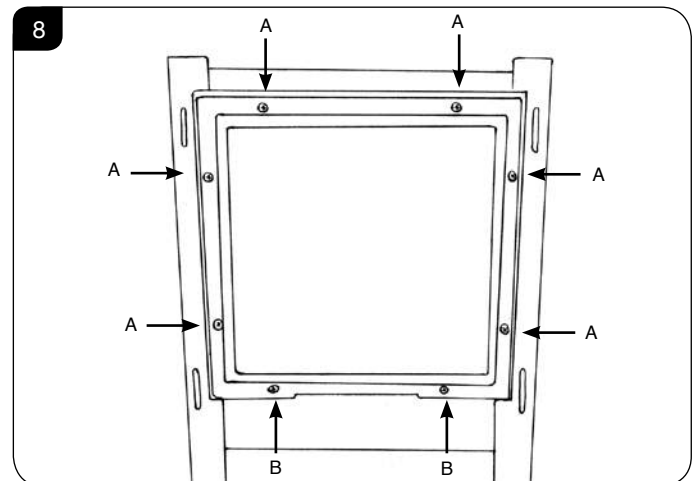

Take care to support the glass when removing the screws.

# Installation Instructions

## 7. Arrangement of the Fuel Bed

### Advice on handling and disposal of fire ceramics



The fuel effect of the log version of this appliance is made from Refractory Ceramic Fibre (RCF), a material which is commonly used for this application.

Protective clothing is not required when handling these articles, but we recommend you follow normal hygiene rules of not smoking, eating or drinking in the work area and always wash your hands before eating or drinking.

To ensure that the release of RCF fibres are kept to a minimum, during installation and servicing a HEPA filtered vacuum is recommended to remove any dust accumulated in and around the appliance before and after working on it. When servicing the appliance it is recommended that the replaced items are not broken up, but are sealed within heavy duty polythene bags and labelled as RCF waste.

RCF waste is classed as stable, non-reactive hazardous waste and may be disposed of at a licensed landfill site.

Excessive exposure to these materials may cause temporary irritation to eyes, skin and respiratory tract; wash hands thoroughly after handling the material.

## 8. Log Layout

### CL3 Layout

**LOGS MUST BE POSITIONED ACCORDING TO THE FOLLOWING INSTRUCTIONS TO GIVE THE CORRECT FLAME EFFECT**

All logs can be identified by a letter (A - E) on their underside. Logs, B and E also have holes to locate each onto a burner stud.

- 8.1 Ensure the burner tray is clean and free from any debris, see Diagram 9.

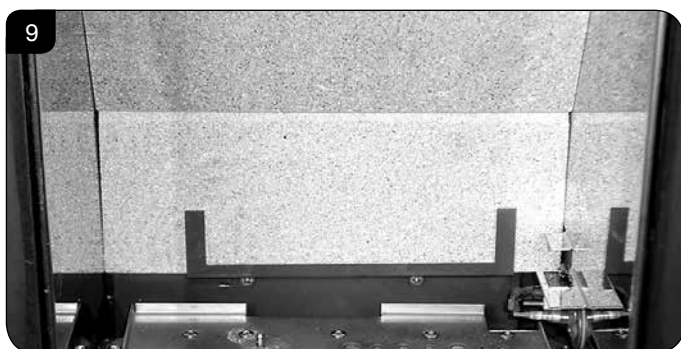

- 8.2 Place Log A on the higher rear bracket and push up against the back panel, see Diagram 10.

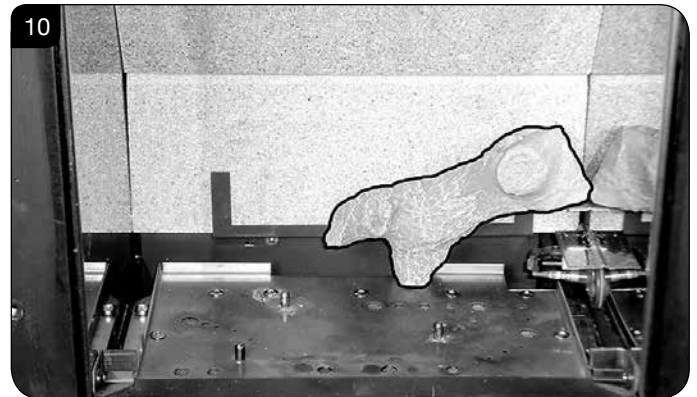

- 8.3 Place Log B over the two middle studs on the burner tray, see Diagram 11.

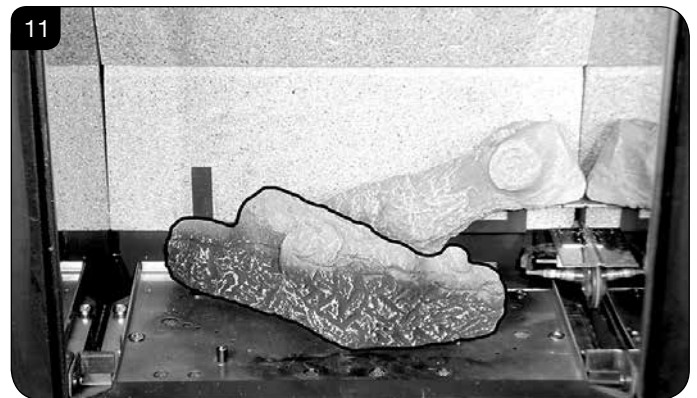

- 8.4 Place Log E onto the stud and behind the tag on the left hand side of the burner tray. Rest against Log B, see Diagram 12.

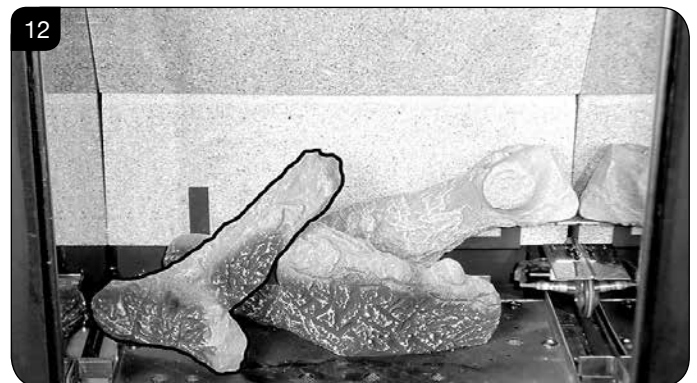



# Installation Instructions

- 8.5 Place the small Ember at the front left of the firebox, against the rear of the log support bracket to obscure the reflection of the burner screw.

Place the larger Ember on the lower bracket above the pilot on the right hand side with the thicker edge facing the front and flat edges to the base and side, see Diagram 13.

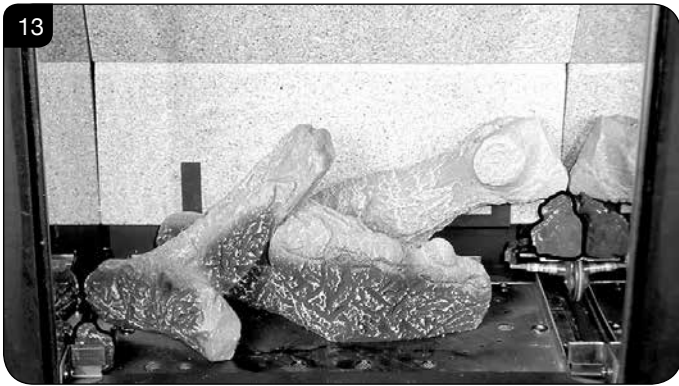

- 8.6 Log C rests on the cutout on Log E and is pushed up to the side and rear of the firebox, see Diagram 14.

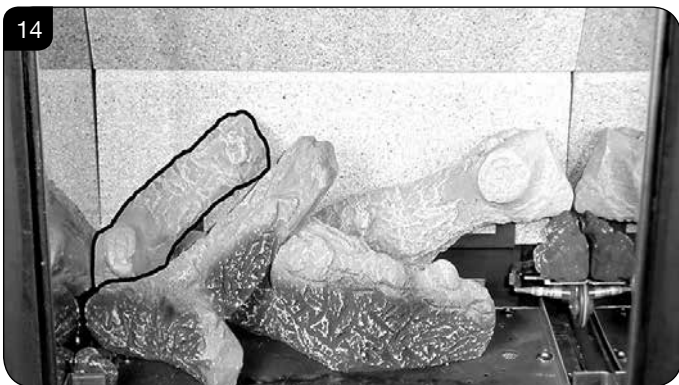

- 8.7 Place the pointed bottom of log D into the corner of the burner tray and rest on the location stud on log B, see Diagram 15.



- 8.8 Use some of the Embaglow provided and cover the ports in the burner tray with a liberal amount of fibres. Use a small piece in front of the log on the left hand side and a long strip in front of log B, see Diagram 16.

NOTE: It is not necessary to use all of the Embaglow.

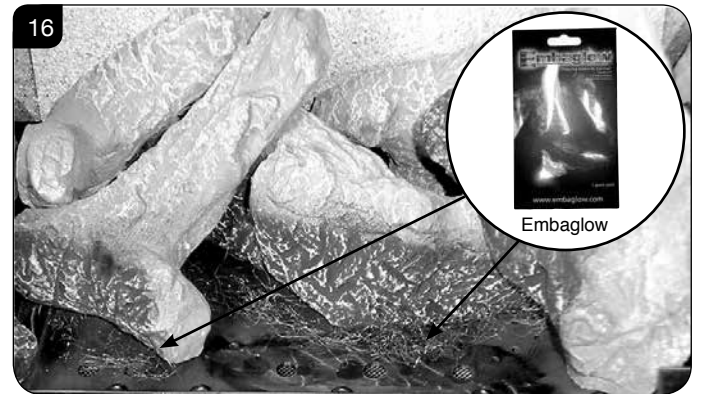

- 8.9 Lower log guard into position, see Diagram 17.



## CL5 Layout

- 8.10 Ensure the burner tray is clean and free from any debris, see Diagram 18.

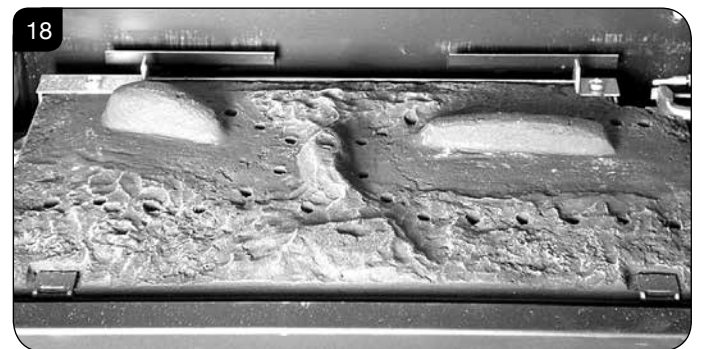



# Installation Instructions

The three logs that make up the fuel bed are visually distinct and fit into specific parts on the burner tray.

- 8.11 Place the rear log into position between the rear brackets and pushed up against the back panel, see Diagram 19.

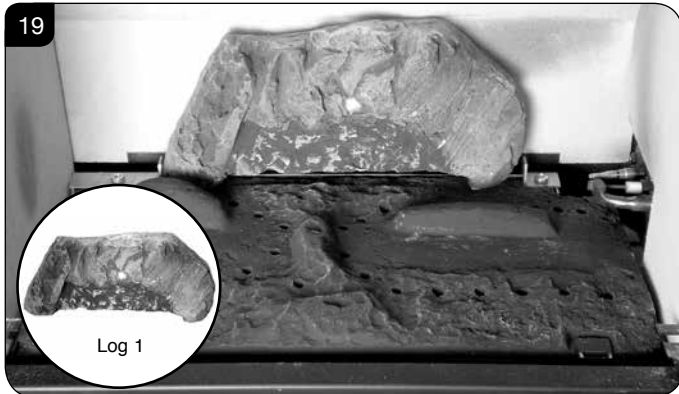

- 8.12 Place the second log into the left hand groove on the burner tray, see Diagram 20. The log should butt up against the raised molding and the left hand side liner.

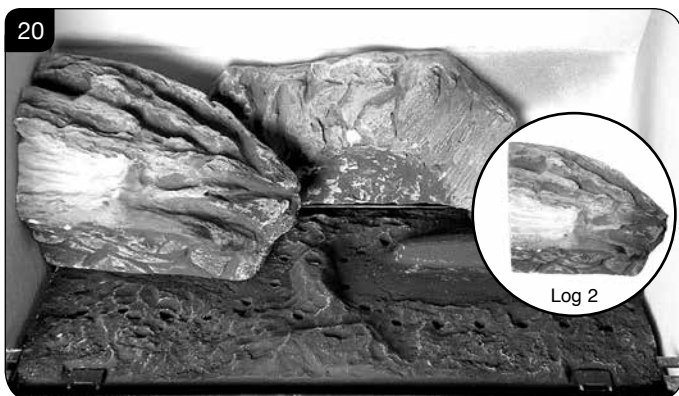

- 8.13 Place the third log into the groove on the right hand side, see Diagram 21. The log should butt up against the raised molding and the right hand side liner.

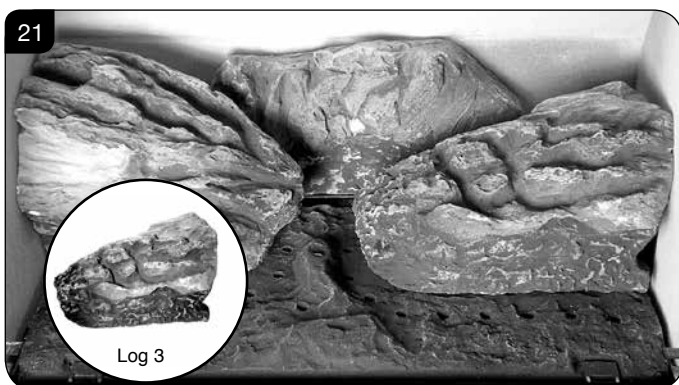

- 8.14 Once the logs are in there are two embers which can be loosely placed at the front of the fuel bed and cover the tabs securing the burner tray, see Diagram 22.

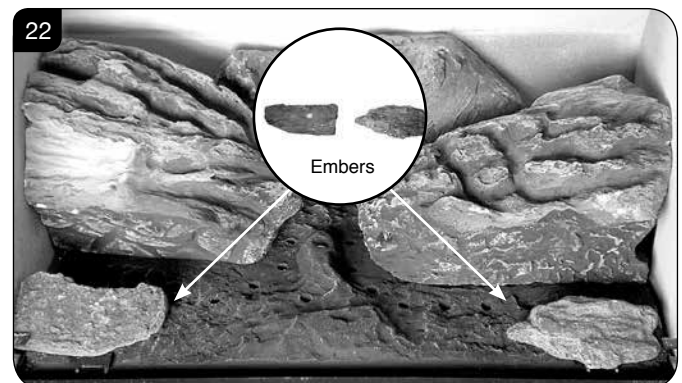

- 8.15 Use some of the Embaglow provided and cover the ports in the burner tray with a liberal amount of fibres, see Diagram 23.

**It is essential to cover the port in the middle of the burner tray in order to get the most visually appealing flame picture.**

NOTE: It is not necessary to use all of the Embaglow.

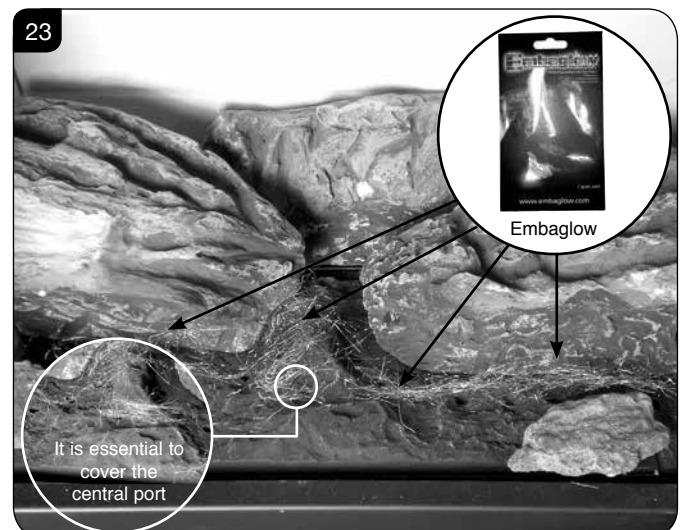

- 8.16 Fix log guard into position, see Diagram 24.

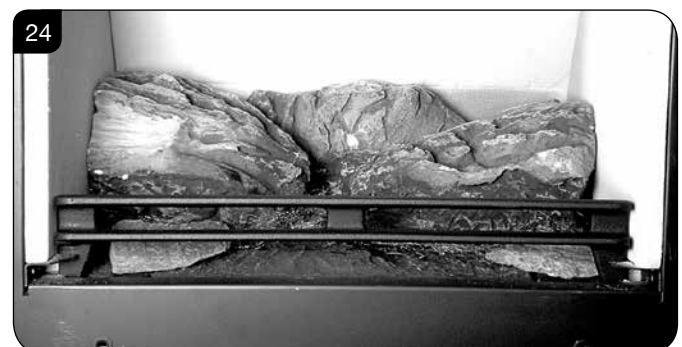

# Installation Instructions

## CL8 Layout

The logs for the fuel bed are clearly individually labelled, A to D.

- 8.17 Ensure the burner tray is clean and free from any debris, see Diagram 25.

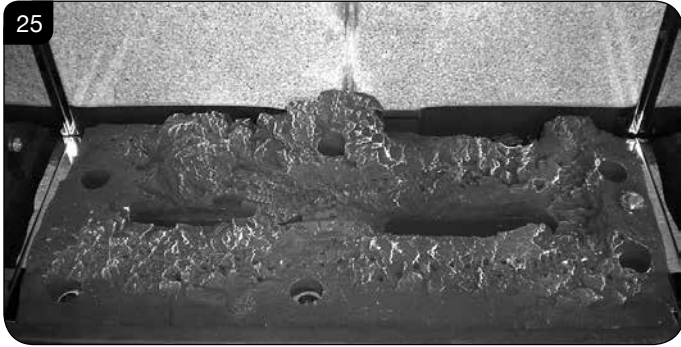

- 8.18 There are 3 embers. Place 2 embers in the back corners of the burner, resting in the cut outs, see Diagram 26. Place the last ember loosely at the front of the fuel bed to cover the hole in the centre.

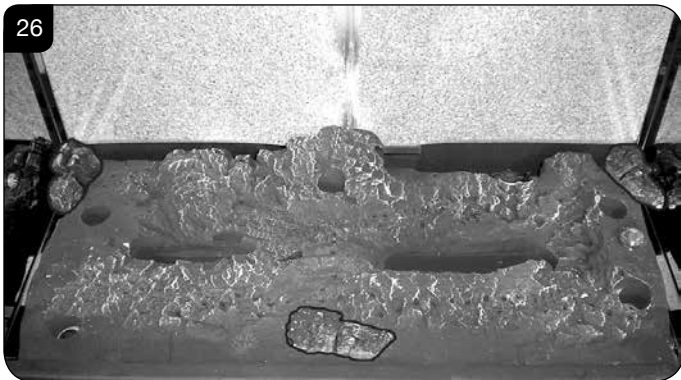

- 8.19 Place Log D on the left hand side of the burner. There is a hole on the underside of Log D which fits over the raised stud on the left of the burner. The back of the log should rest flat against the back panel, see Diagram 27.

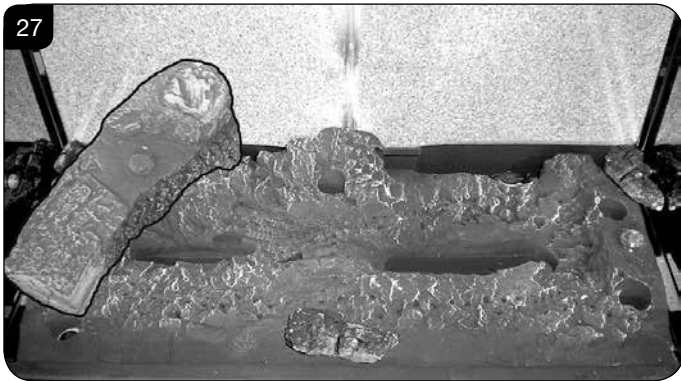

- 8.20 Place Log B on top of Log D. There is a hole on the underside of Log B which fits over the raised stud on Log D to secure in place. The right hand side of the log rests in the groove in the burner, see Diagram 28.

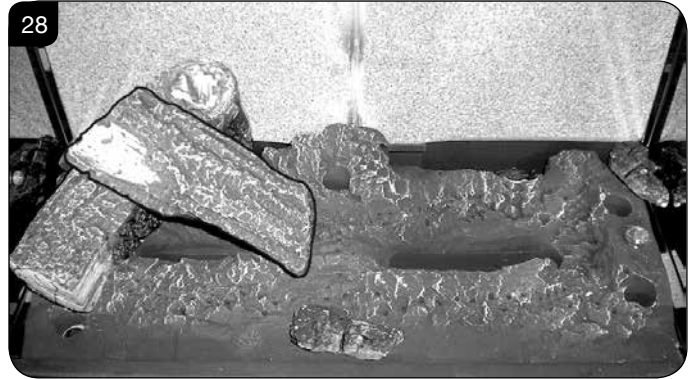

- 8.21 Place Log C on the right hand side of the burner. There is a hole on the underside of Log C which fits over the raised stud on the right of the burner. The back of the log should rest flush against the back panel, see Diagram 29.



- 8.22 Place the log guard into position on the grooves on the sides of the firebox, see Diagram 30.



# Installation Instructions

8.23 Place Log A across Log C. There is a hole on the underside of Log A which fits over the raised stud on Log C to secure in place. The small cut out on the left side of the log rests onto the log guard, see Diagram 31.



8.24 Once the logs are in place use some of the Embaglow wire wool provided and cover the ports in the burner tray with a liberal amount of fibres, in the highlighted areas shown in Diagram 32.

**NOTE:** It is not necessary to use all of the Embaglow. **IT IS ESSENTIAL TO KEEP THE REAR PORT FREE FROM OBSTRUCTION**

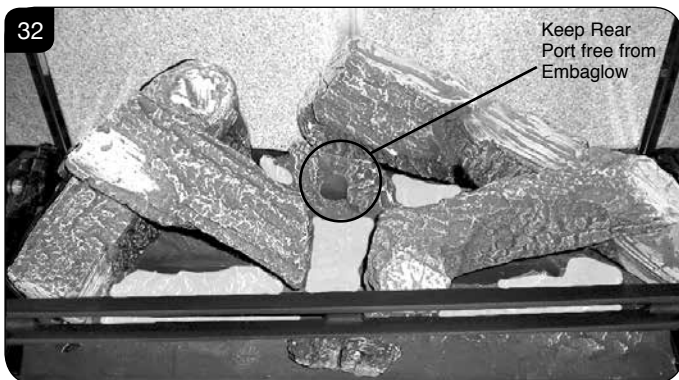

## 9. Completion of Assembly

9.1 To fit the window frame:

**CL3 and CL5 only:**

Offer the frame to the foot of the opening and secure using 6 screws as shown, see Diagram 33, Arrow A.

**CL8 only:**

Offer the frame to the foot of the opening and secure using 8 screws as shown, see Diagram 33, Arrow A & B.

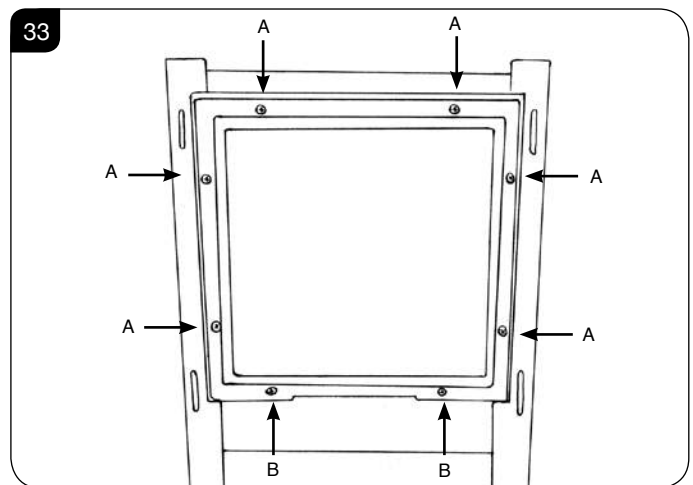

9.2 Replace ALL of the glass frame securing screws ensuring that a screw is present in all fixing slots.

**! UNDER NO CIRCUMSTANCES SHOULD THE APPLIANCE BE USED IF ANY OF THE GLASS FRAME RETAINING SCREWS ARE LOOSE OR MISSING.**

# Installation Instructions

- 9.3 Fit the front and the plinth by inserting the hooks on the back of the frame into the slots on the front of the appliance, see Diagram 34 & 35.

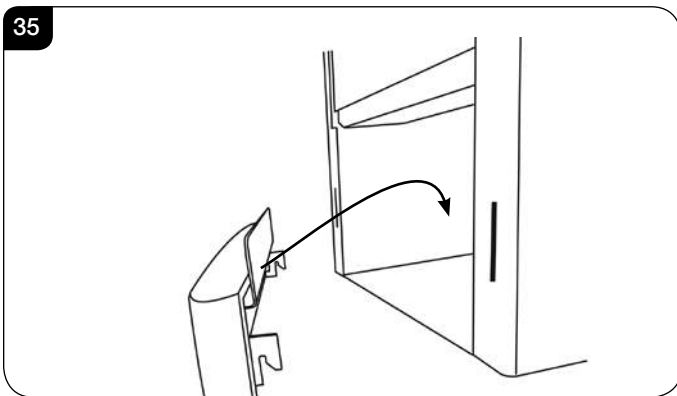
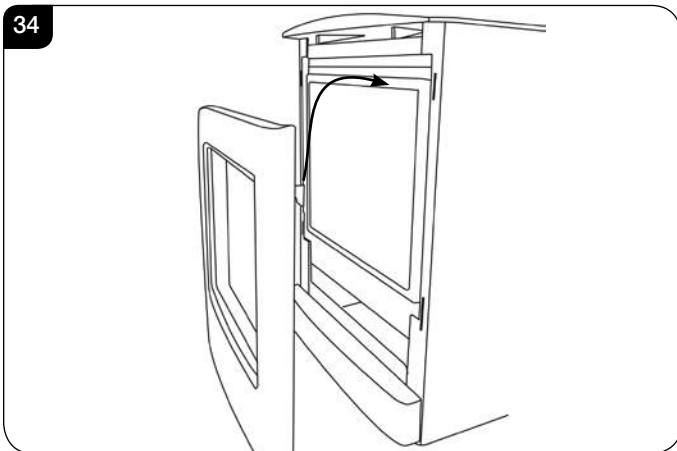

## 10. Operating the Appliance

The control valve is located behind the plinth.

- 10.1 Remove the plinth to access the controls by lifting the hooks clear of the slots on the front of the appliance, see Diagram 36.

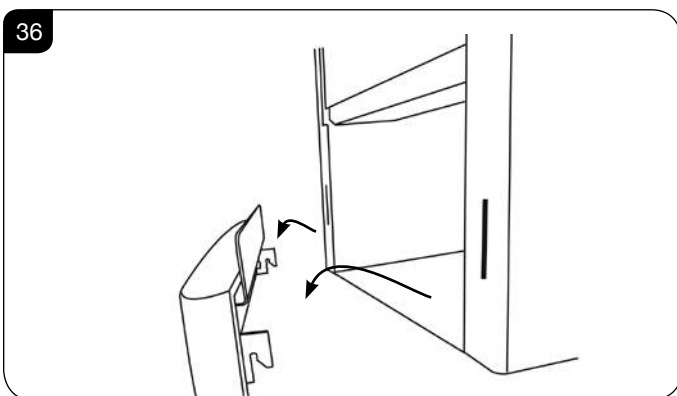

The valve has two controls, see Diagram 37.

1. The right-hand knob controls the pilot ignition.
2. The left-hand knob controls the main burner.

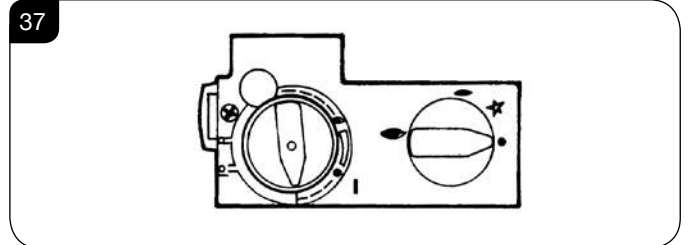

- 10.2 Refer to separate instructions if your appliance is upgraded to include battery remote control. The instructions below apply whether or not you have the remote upgrade.

### Lighting the Pilot

- 10.3 To start the left-hand and right-hand control knobs must both point to off (●):
- 10.4 Press in the right-hand control knob and rotate anti-clockwise until a click is heard. Continue to press in. The knob points to the pilot (←).

The pilot is lit.

- 10.5 Keep the knob depressed for 10 seconds before releasing. The pilot remains lit.

Repeat the above steps if the pilot does not stay lit.

**NOTE: If the pilot goes out, the Interlock system prevents you lighting again for a short period.**

- 10.6 If, after repeating the above steps the pilot does not light, contact your Retailer or Installer.
- 10.7 Turn the right-hand knob to the left to main burner setting (↖).

### Adjusting the Flame height

- 10.8 You can now adjust the flame height and temperature using the left-hand control knob.
- 10.9 Turn the left-hand knob anti-clockwise to increase the flame height.
- 10.10 Turn clockwise to decrease the height.



**IMPORTANT: YELLOW FLAMES TYPICALLY APPEAR WHEN THE APPLIANCE HAS REACHED NORMAL OPERATING TEMPERATURE. THIS CAN TAKE UP TO 30 MINUTES.**



**WARNING: IF THE APPLIANCE FAILS TO LIGHT OR BECOMES EXTINGUISHED IN USE, WAIT 3 MINUTES BEFORE ATTEMPTING TO RELIGHT.**

## 1. Commissioning

- 1.1 Close all doors and windows in the room.
- 1.2 Ignite the appliance and operate on maximum for 10 minutes.
- 1.3 Position a lighted smoke match just inside the draught diverter opening at the rear of the appliance.
- 1.4 Check all smoke is drawn into the opening, see Diagram 1.

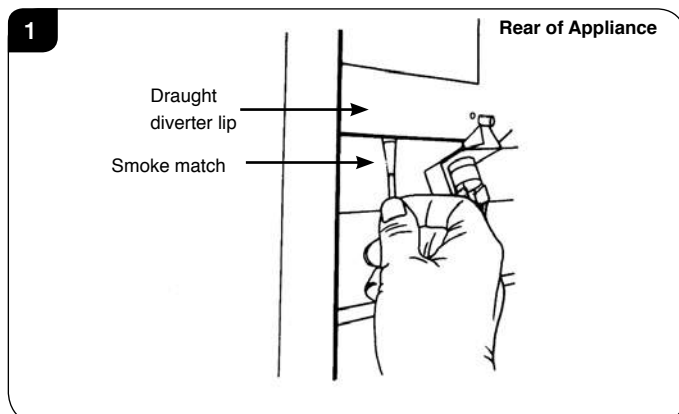

- 1.5 If there is any doubt, run the appliance for a further 10 minutes, and repeat the test.
- 1.6 If there are any extractor fans in adjacent rooms, the test must be repeated with the fans running on maximum and interconnecting doors open.

**IF SPILLAGE PERSISTS, DISCONNECT THE APPLIANCE AND SEEK EXPERT ADVICE.**

- 1.7 Complete the Commissioning Checklist at the front of this manual covering:
  - Flue checks
  - Gas checks
  - Log layout - flame picture
- 1.8 Ensure all safety checks listed in the Commissioning Section are completed, paying particular attention to the glass panel checks and securing of the glass frame.
- 1.9 Upon completion of the commissioning and testing of the installation and correct operation of the appliance, the installer must instruct the user how to operate the appliance.
- 1.10 Guide the user through the User Instructions paying particular attention to:
  - a) Regular servicing (Section 10 of the User Instructions).
  - b) Ventilation (Section 11 of the User Instructions) - point out the ventilation positions where applicable.
  - c) Hot surfaces (Section 13 of the User Instructions).

# Servicing Instructions

## Servicing/Fault Finding Charts

### 1. Servicing Requirements

**IMPORTANT – The glass panel on this appliance should be checked for any signs of damage on the front face of the glass panel (scratches, scores, cracks or other surface defects). If damage is observed, the glass panel must be replaced and the appliance must not be used until a replacement is installed. Under no circumstances should the appliance be used if any damage is observed. Please isolate the appliance until a replacement glass panel has been obtained and installed. Replacement glass panels can be purchased from Yeoman via the retailer from which the appliance was purchased or any other Yeoman distributor.**

This appliance must be serviced at least once a year by a competent person.

All tests must be carried out in accordance with the current Gas Safe recommendations.

#### 1.1 Before Testing:

- Conduct a gas soundness test for the property ensuring there are no leaks before servicing.
- Check the operation of the appliance before testing.

#### 1.2 Special checks:

- Clean the burner using a vacuum cleaner with a soft brush attachment. Ensure all debris is removed from the burner ports.
- Clean away lint or fluff from the pilot.
- Clean away lint or fluff from under the burner.
- Check the spark gap on the pilot is correct.
- Ensure that the glass frame is secured correctly and that all retaining screws are in place.

#### 1.3 Correct any faults found during the initial test.

#### 1.4 Re-commission the appliance in accordance with Commissioning Procedures.

#### 1.5 Advise the customer of any remedial work undertaken.

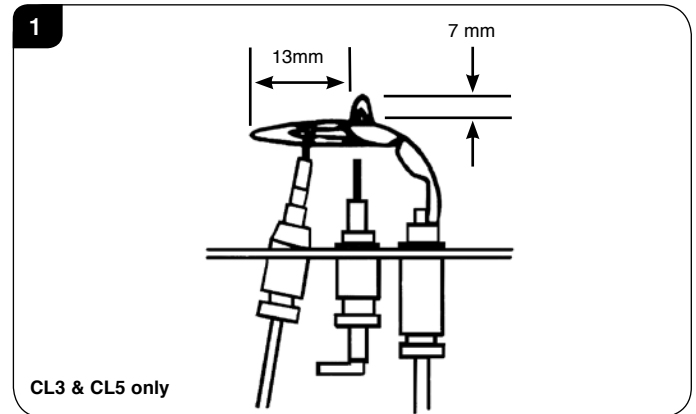

### IGNITION FUNCTIONAL CHECK 1

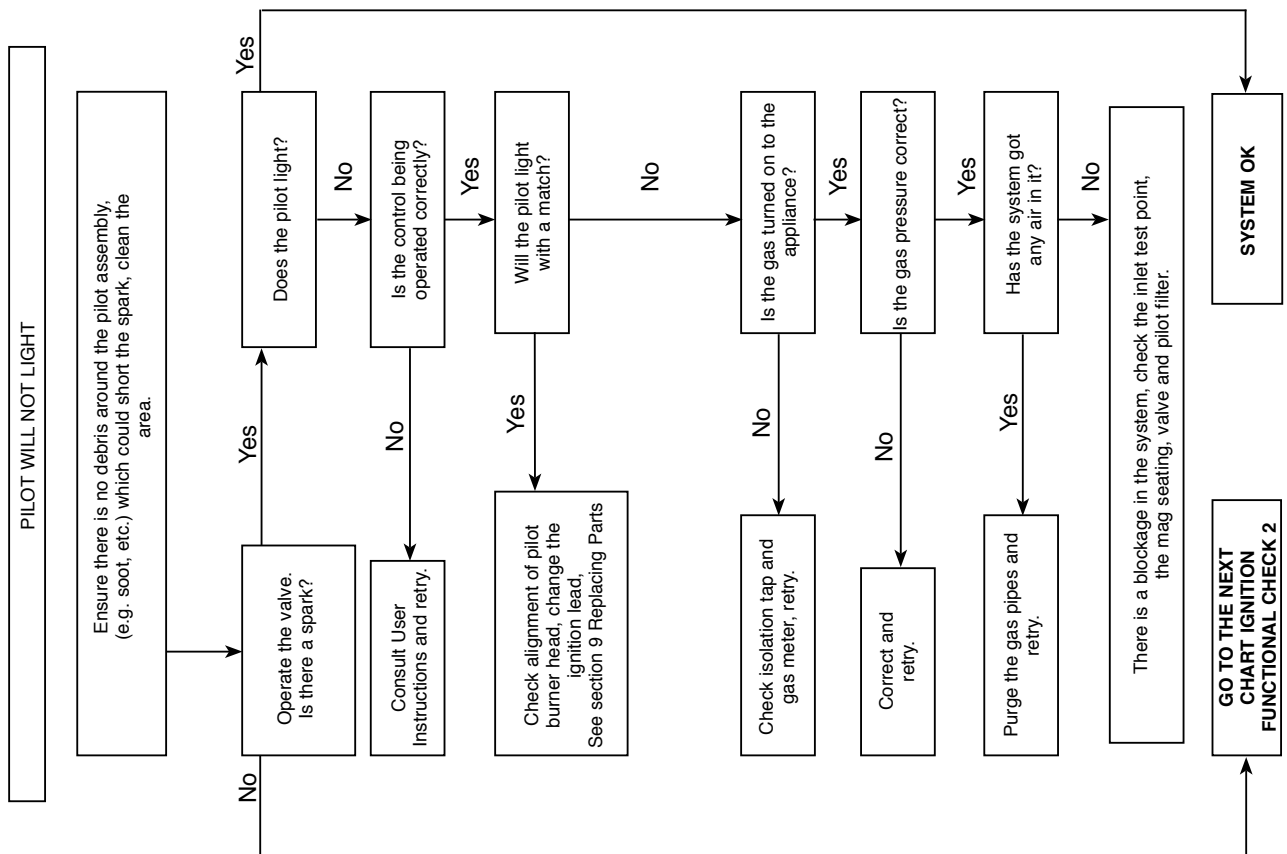



# Servicing Instructions

## Fault Finding Charts

### FLAME FAILURE FUNCTIONAL CHECK 3

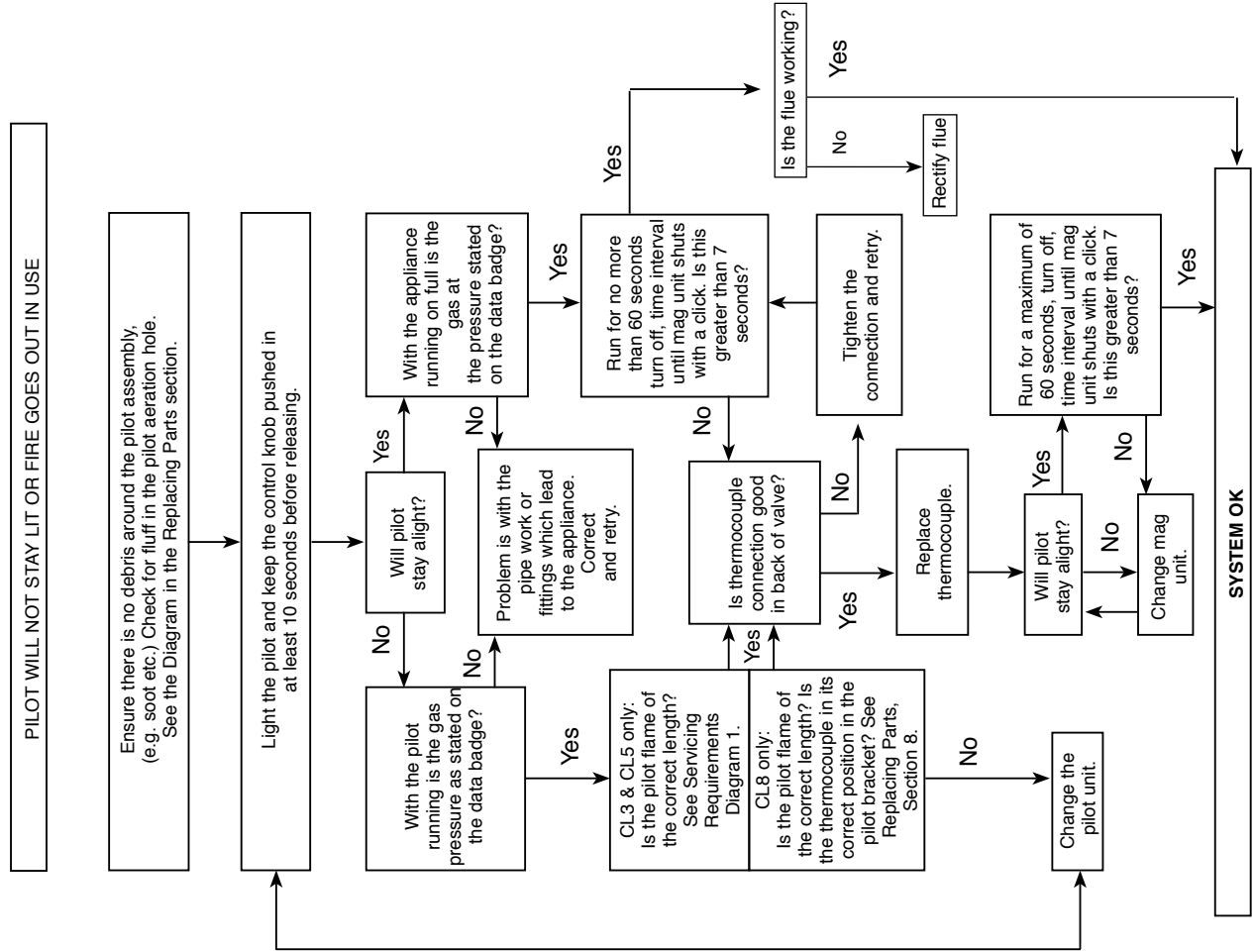

### IGNITION FUNCTIONAL CHECK 2

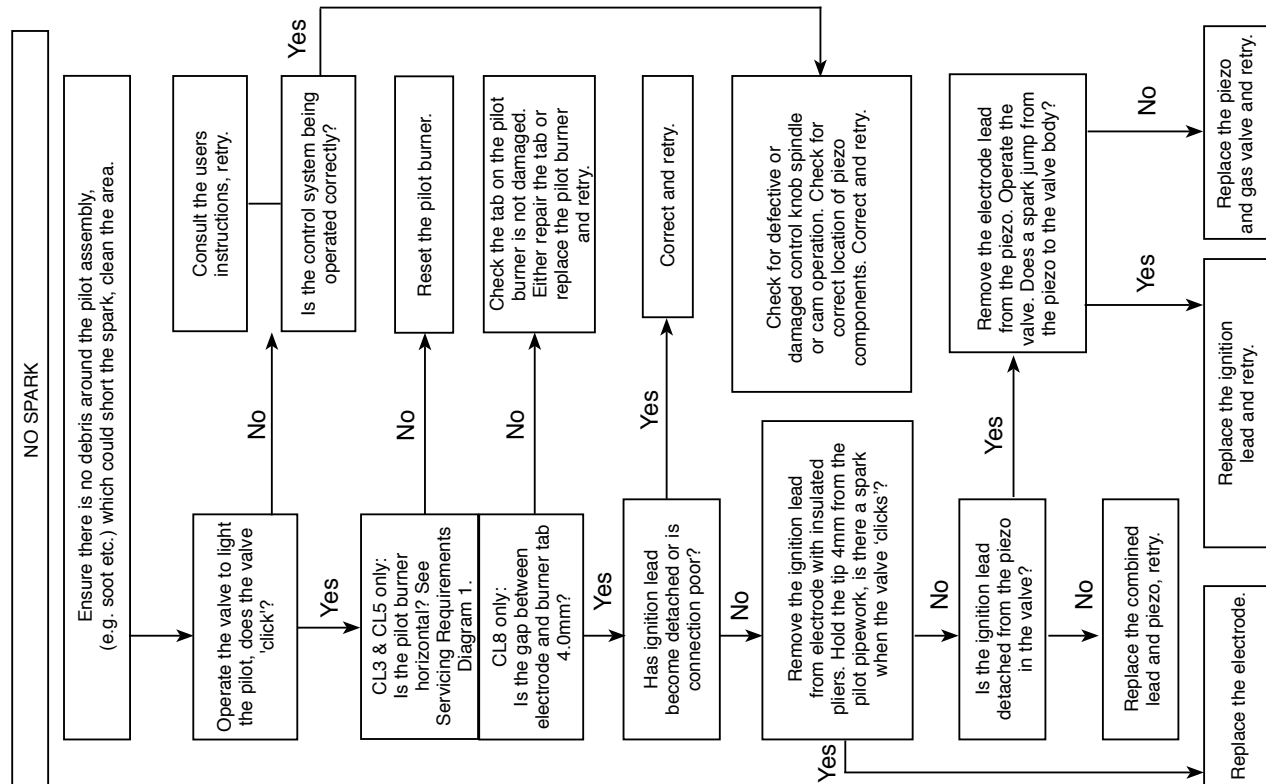

# Servicing Instructions - Replacing Parts

## 1. General

- 1.1 All main components can be replaced without removing the appliance from its installation.

**IT IS ESSENTIAL THAT THE GAS SUPPLY TO THE APPLIANCE IS TURNED OFF AT THE ISOLATION DEVICE BEFORE PROCEEDING FURTHER.**

## 2. Decorative Front



**IMPORTANT: THE OUTER PANELLING OF THE YEOMAN CL IS MADE FROM CAST IRON. USE CAUTION WHEN INSTALLING, REMOVING AND STORING AS THE COMPONENTS ARE HEAVY AND SHOULD BE HANDLED CAREFULLY.**

### All Models

- 2.1 Remove the plinth to access the controls by lifting the hooks clear of the slots on the front of the appliance, see Diagram 1.

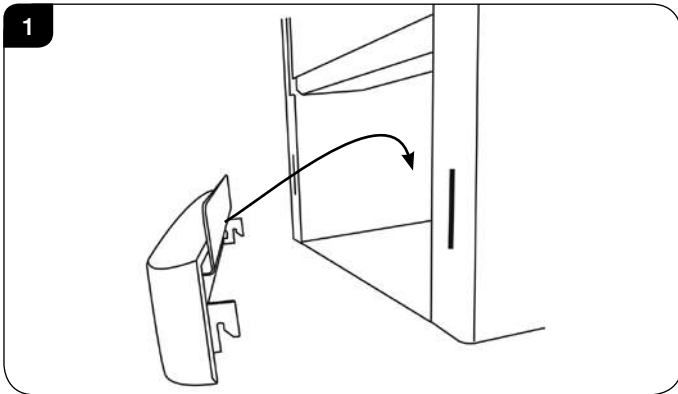

- 2.2 Remove the frame to gain complete access to the control valve and the viewing aperture by lifting the hooks clear of the slots on the front of the appliance, see Diagram 2.

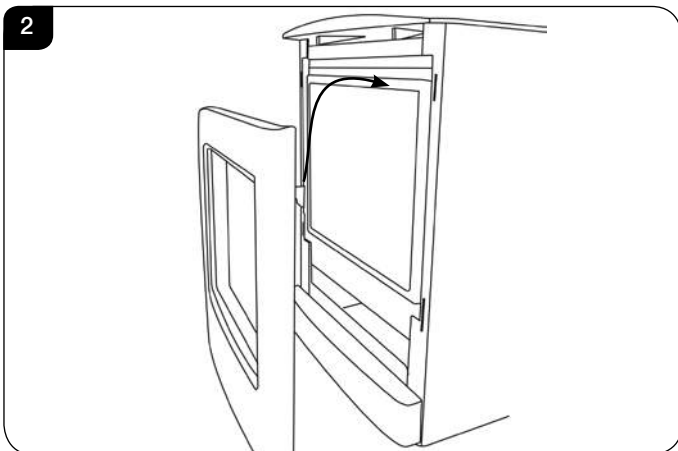

## 3. Window Frame Assembly

### CL3 and CL5 only:

- 3.1 Using screwdriver remove the 6 screws securing the window panel to the appliance, see Diagram 3, Arrows A. Take care to support the glass when removing the screws.

### CL8 only:

- 3.2 Using screwdriver remove the 8 screws, securing the window panel to the appliance, see Diagram 3, Arrows A & B. Take care to support the glass when removing the screws.

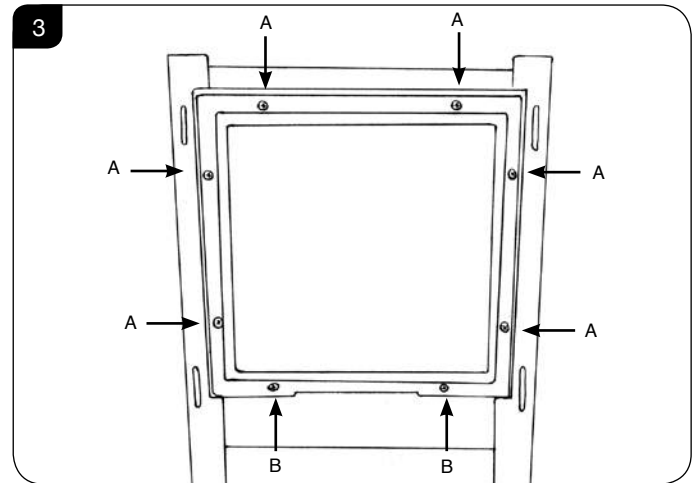

- 3.3 Place carefully to one side.
- 3.4 The glass frame must be refitted to the appliance following cleaning or servicing. Hold in position and secure with the screws.
- 3.5 Replace ALL of the securing screws ensuring that a screw is present in all fixing slots.



**UNDER NO CIRCUMSTANCES SHOULD THE APPLIANCE BE USED IF ANY OF THE GLASS FRAME RETAINING SCREWS ARE LOOSE OR MISSING.**

# Servicing Instructions - Replacing Parts

## 4. Baffle & Liners

4.1 To access the burner tray and interior workings of the appliance it may be necessary to remove the baffle and the liners.

### 4a. Baffle & Liners (CL3 only)

#### BAFFLE

4.2 There is no requirement to remove the baffle for servicing.

#### LINERS

4.3 The burner can be accessed without the need to remove the side liner panels. If they need to be taken out then first remove the screws securing the two brackets on either side of the firebox. The panels will now slide forward, see Diagram 4.

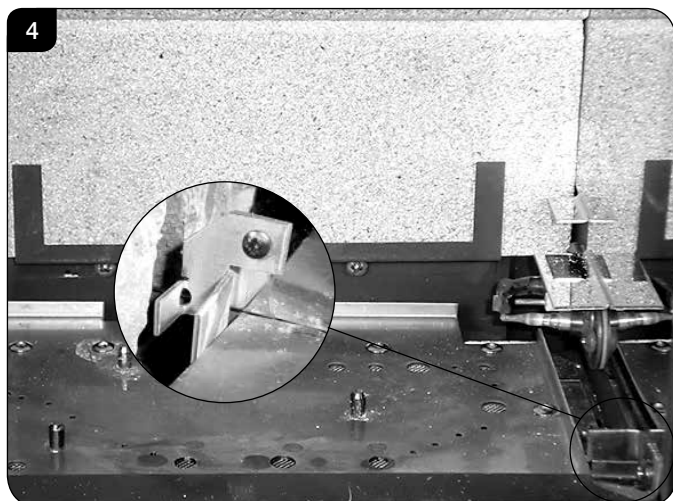

4.4 Gently lift the upper rear liner and pull forwards. With the panel raised it should be possible to remove from the liner brackets, see Diagram 5.  
Note: It may be necessary to use a flat object like a screwdriver to separate the two panels.

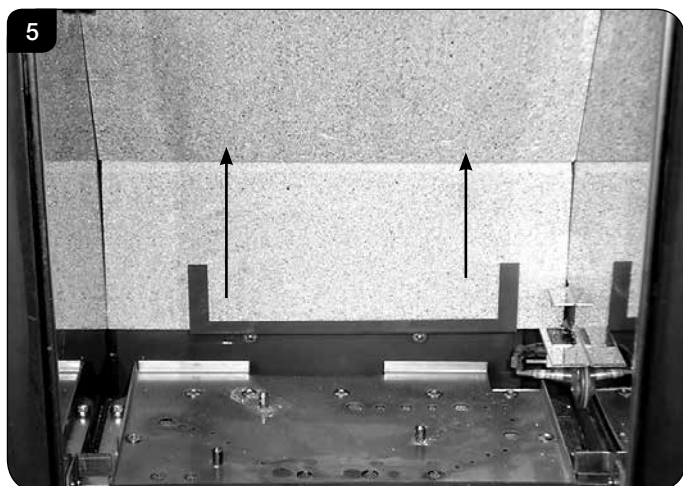

4.5 Slide the lower rear liner up and out of the lower bracket, see Diagram 6.

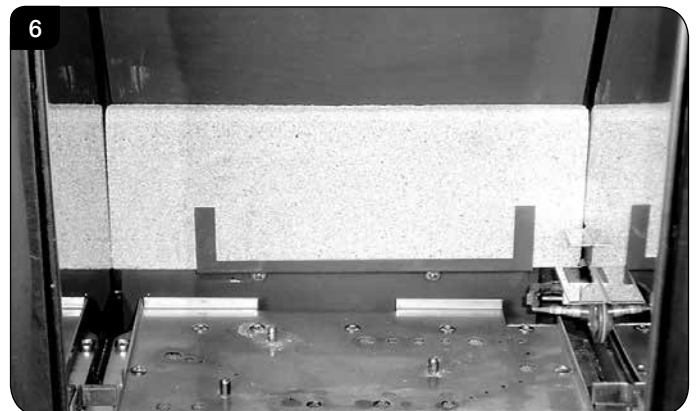

4.6 Replace all parts in reverse order ensuring the cutouts in the rear of the lower panel fit over the screws on the back of the firebox, see Diagram 7.

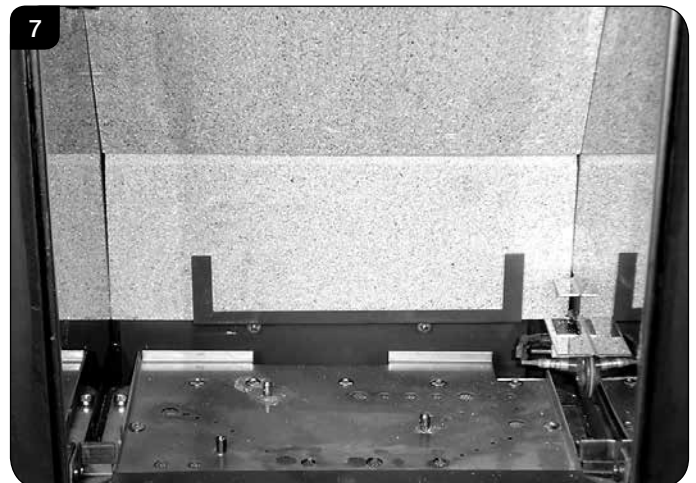

### 4b. Baffle & Liners (CL5 only)

#### BAFFLE

4.7 The baffle must be removed before the liners can be taken out of the appliance.

To do this undo the two screws securing it to the roof of the firebox, see Diagram 8.



4.8 The baffle can now be removed through the front of the appliance.

# Servicing Instructions - Replacing Parts

## CERAMIC LINERS

Once the baffle has been placed carefully to one side the liners can then be taken out in the following order.

- 4.9 To remove the Left Hand liner first tilt inwards towards the centre of the firebox before lifting up and pulling out through the front of the firebox, see Diagram 9.

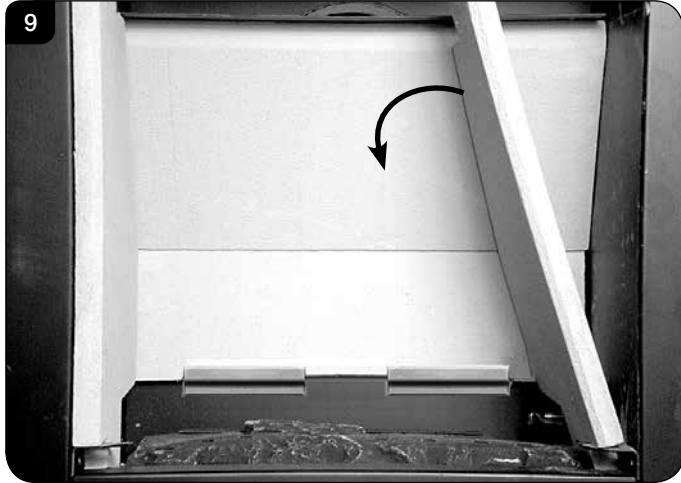

- 4.10 To remove the Right Hand liner first tilt inwards towards the centre of the firebox before lifting up and pulling out through the front of the firebox, see Diagram 10.

The two side liners also support the raised rear liner. Taking out the side liners will allow the rear liner to drop down so ensure it is supported and removed carefully, see Diagram 10.



- 4.11 The lower rear liner does not need to be removed from the bracket in order to access the burner tray for maintenance, but can be lifted off in order to clean or replace, see Diagram 11.

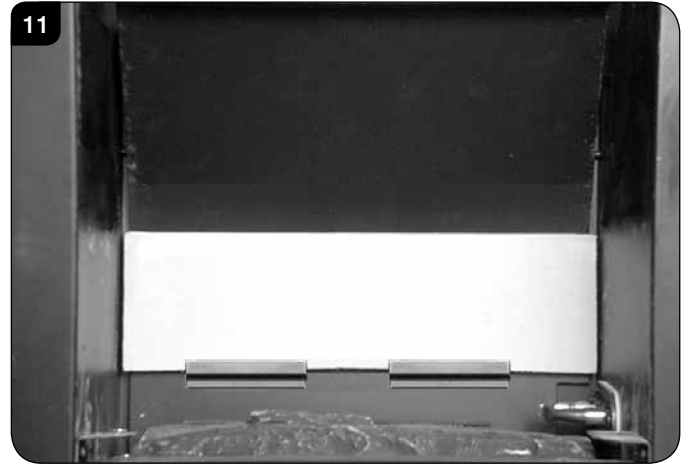

- 4.12 With the liners and baffle removed the firebox is clear for cleaning and maintenance, see Diagram 12.

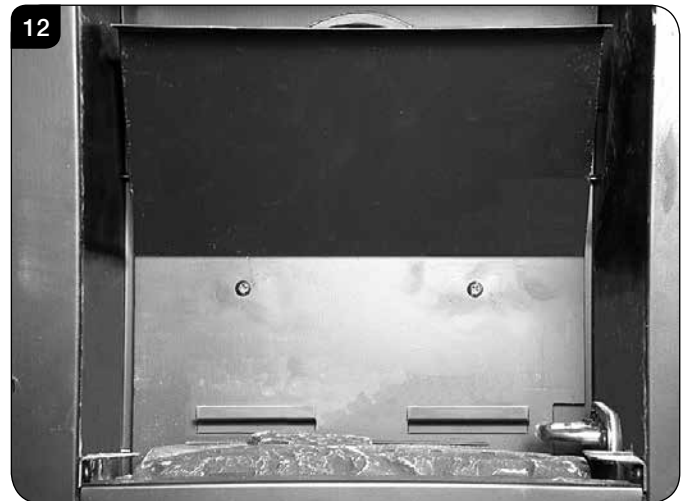

- 4.13 To replace the liners and baffle reverse these procedures.

### 4c. Baffle & Liners (CL8 only)

- 4.14 To access the burner tray and interior workings of the appliance it may be necessary to remove the baffles and the liners.
- 4.15 This appliance has 2 baffles, 1 metal and 1 vermiculite, that must be removed before the liners can be taken out of the appliance.
- 4.16 Remove the logs.

# Servicing Instructions - Replacing Parts

## METAL BAFFLE

To remove the metal baffle:

- 4.17 Undo the 3 screws securing it to the roof of the firebox, see Diagram 13.

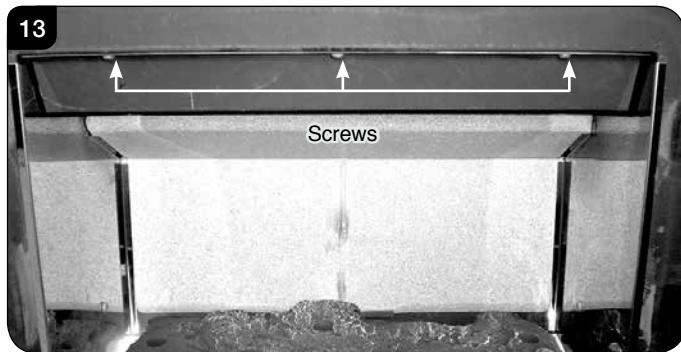

- 4.18 The baffle can now be removed through the front of the appliance.

## VERMICULITE BAFFLE

To remove the vermiculite baffle:

- 4.19 Lift the vermiculite baffle and slide out through the front of the appliance, see Diagram 14.

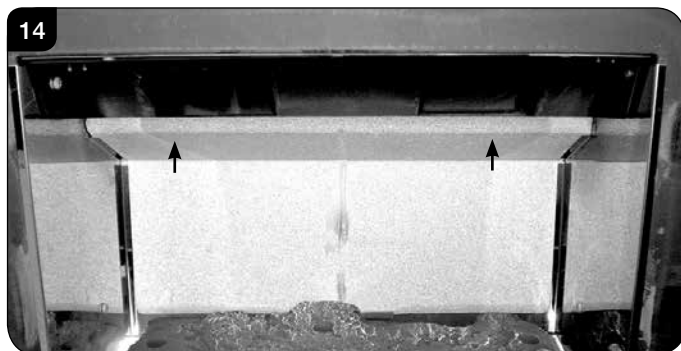

Once the baffles have been placed carefully to one side the liners can then be taken out in the following order.

## REFLECTIVE LINERS

- 4.20 To remove the left hand liner undo the 3 screws, including the 1 under the log guard bracket, see Diagram 15.

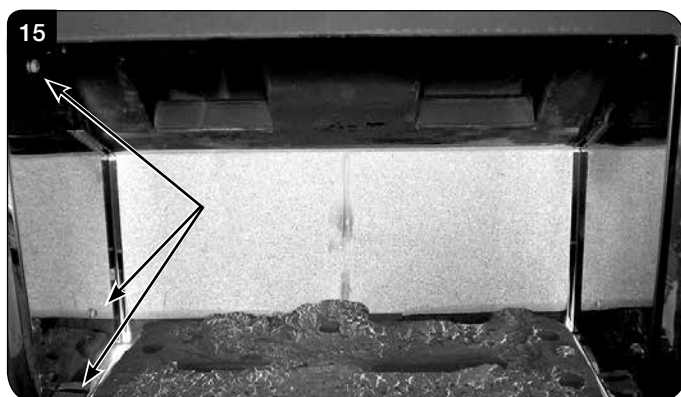

- 4.21 Remove the log guard bracket.

- 4.22 Tilt the liner inwards towards the centre of the firebox before lifting up and pulling out through the front of the firebox, see Diagram 16.

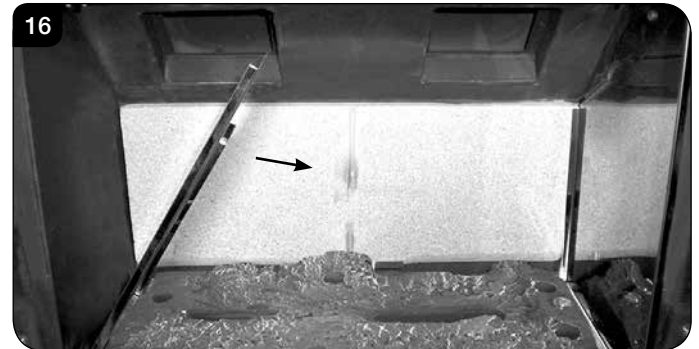

- 4.23 To remove the right hand liner undo the 3 screws, including the 1 under the log guard bracket, see Diagram 15.

- 4.24 Remove the log guard bracket.

- 4.25 Tilt the liner inwards towards the centre of the firebox before lifting up and pulling out through the front of the firebox, see Diagram 16.

## VERMICULITE LINER

- 4.26 The rear liner does not need to be removed in order to access the burner tray for maintenance, however it is advisable to remove the rear panel to avoid possible damage and to clean or replace.

- 4.27 To remove the back panel lift out of the bracket and remove through the front of the appliance, see Diagram 17.

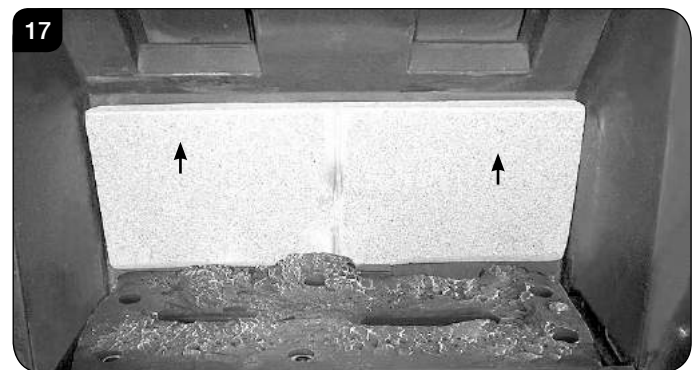

- 4.28 With the liners and baffle removed the firebox is clear for cleaning and maintenance, see Diagram 18.

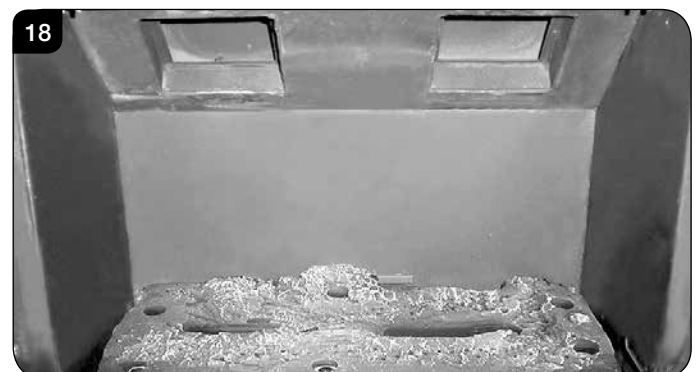



# Servicing Instructions - Replacing Parts

## 5. Main Burner

5.1 To replace the main burner:

Remove the baffle and enamel liners, see Section 4.

5.2 Remove the three securing screws from the edges of the burner, see Diagram 19.

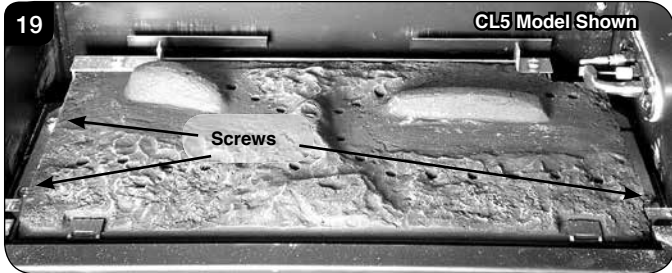

5.3 Slide the burner fully to the right whilst lifting the Left Hand side clear of the bracket, see Diagram 20.

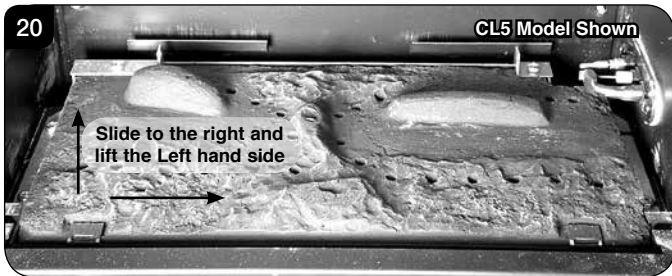

5.4 Slide the burner back to the left and out of its location.  
**IMPORTANT: Take care when removing the burner not to damage the ceramic pad with the pilot unit attached.**

Refit in reverse order.

## 6. Control Assembly

6.1 It is not necessary to remove the complete control assembly to service or replace parts of this appliance. The following sections will detail how to individually remove and replace each element.

## 7. Pilot Unit

### 7a. CL3 & CL5

The pilot assembly consists of five components, which can be individually changed, these are:

- Pilot burner bracket.
- Pilot Injector
- Electode
- Thermocouple.
- Gasket.

7.1 Turn the gas supply off at the isolation device, remove the door and place to one side, carefully remove the ceramic fuel bed components.

### Pilot Burner Bracket

7.2 Remove the two fixing screws from the pilot bracket, see Diagram 21. Gently draw the assemble away from the firebox to give access to the nuts and ignition lead.

**NOTE: TAKE CARE NOT TO DAMAGE THE GASKET.**

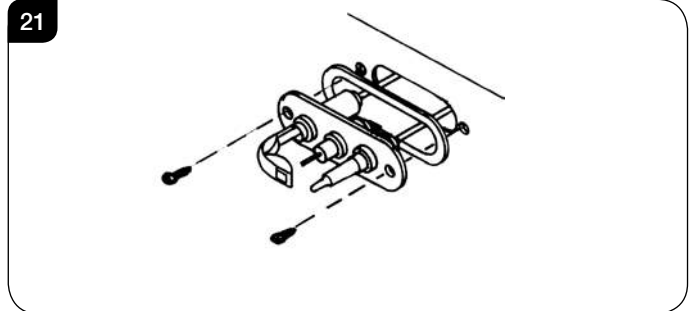

### Pilot Injector

7.3 Undo the compression nut on the pilot feed pipe and withdraw the injector which will be hooked onto the olive. When replacing an injector always make sure it is hooked onto the olive before inserting it into the pilot burner, see Diagram 22.

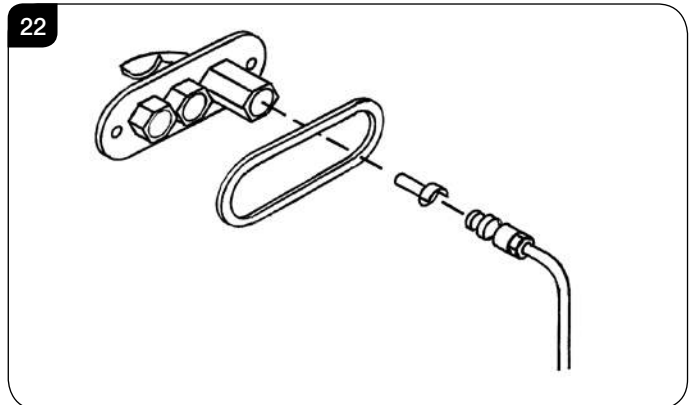



# Servicing Instructions - Replacing Parts

## Electrode

- 7.4 Disconnect the ignition lead and undo the retaining nut. The electrode can now be removed, note the orientation of the electrode terminal when reassembling, see Diagram 23.

23

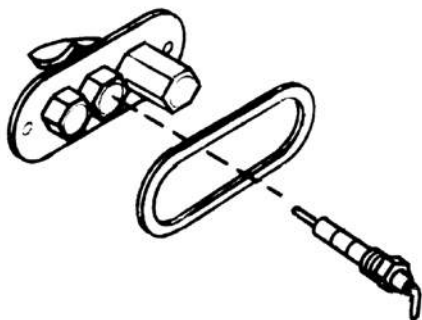

## Thermocouple

- 7.5 Undo the retaining nut and withdraw the thermocouple. Undo the thermocouple from the back of the gas valve, see Diagram 24. Reassemble in reverse order. Do not overtighten.

24

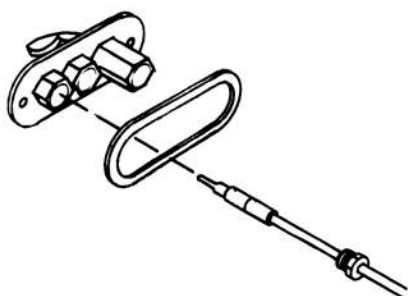

## Gasket

- 7.6 Disconnect all the above components and withdraw the gasket. If it is damaged, replace with a new item. Always replace the gasket first when reassembling the pilot components.

## 7b. CL8

The pilot assembly consists of four components which can be individually changed:

- Pilot burner bracket
- Electrode
- Pilot injector
- Thermocouple

25

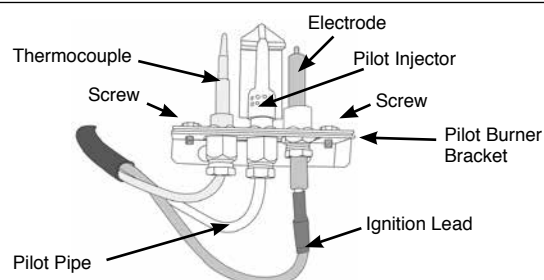

**NOTE: Ensure the sealant surrounding the Electrode and Thermocouple leads is replaced if disturbed or removed whilst gaining access to these components.**

- 7.7 Turn the gas supply off at the isolation device, remove the door and place to one side, carefully remove the ceramic fuel bed components.

## Pilot Burner Bracket

To remove the Pilot Burner Bracket:

- 7.8 **First remove the electrode, pilot pipe and thermocouple as described in the following sections.**
- 7.9 Remove the 2 screws securing the bracket. The pilot burner bracket can now be removed.
- 7.10 Replace in reverse order.

## Electrode

- 7.11 Pull the ignition lead off the electrode and undo the retaining nut, see Diagram 25.
- 7.12 Replace with a new electrode. Do not overtighten the nut; this could break the component.
- 7.13 Replace the ignition lead by pushing the spade connector onto the terminal (electrode).

## Pilot Injector

- 7.14 Undo the pilot pipe from the gas valve and from the underside of the pilot burner, see Diagram 25.
- 7.15 Remove the pipe and the injector drops out from the burner.

# Servicing Instructions - Replacing Parts

## Thermocouple

- 7.16 Disconnect the thermocouple from the gas valve/interrupter.
- 7.17 Remove the 2 interrupter leads.
- 7.18 Undo the thermocouple nut in the back of the pilot bracket half a turn. This releases the thermocouple.
- 7.19 When replacing with a new thermocouple, take care to bend the new component to the same shape as the thermocouple just removed.
- 7.20 To refit the thermocouple into the pilot bracket, ensure it is pushed fully into the hole. There is a stop on the thermocouple to set the height.
- 7.21 Lock the retaining nut just enough to grip the thermocouple.
- 7.22 Connect the thermocouple to the valve/interrupter **taking care not to overtighten.**

## 8. Ignition Lead

- 8.1 Follow the Pilot Unit instruction to access the back of the pilot assembly.
- 8.2 Disconnect the ignition lead from the electrode.
- 8.3 Remove the front cover from the control valve by removing the retaining screw, see Diagram 26 and gently levering clear with flat bladed screwdriver, see Diagram 27.

**NOTE: There is a small cylindrical metal spacer inside the cover, this must be kept and replaced on the fixing screw on re-assembly.**

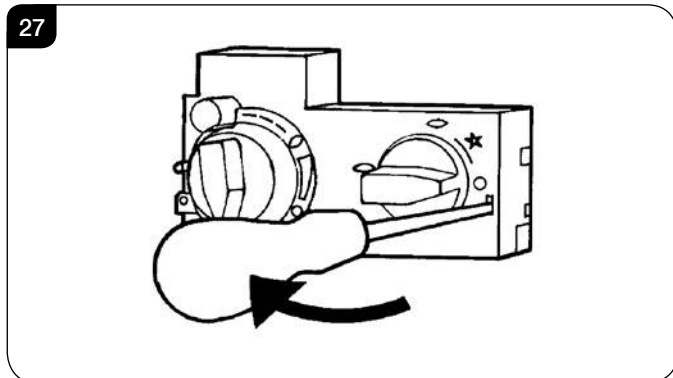
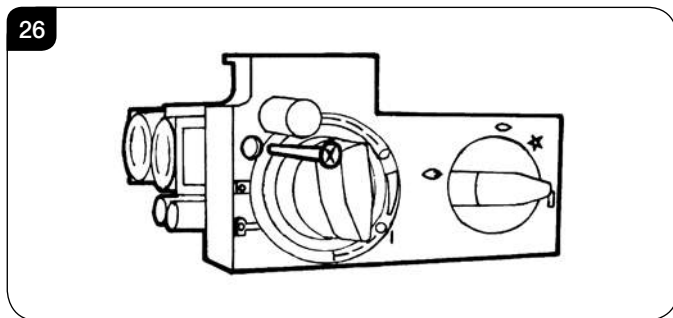

- 8.4 Disconnect the other end of the ignition lead from the valve body noting the route of the ignition lead.
- 8.5 Replace with a new ignition lead following the same route as the old one.  
  
Replace the valve cover and the pilot assembly.
- 8.6 Check operation of the new ignition lead.

## 9. Piezo

- 9.1 The piezo assembly used on this appliance is not serviceable and is not likely to fail.
- 9.2 If a new piezo is required it will be necessary to change the valve, see Section 10.

## 10. Gas Valve

- 10.1 To remove the valve turn off the gas supply at the isolation device.
- 10.2 Remove the main burner, see Section 6.
- 10.3 From inside the firebox remove the locknut from the injector, see Section 12.

## CL3 & CL5

- 10.4 Remove the pilot feed pipe from the pilot unit, see Section 8.
- 10.5 Remove the 2 screws at the front of the valve bracket, see Diagram 28.

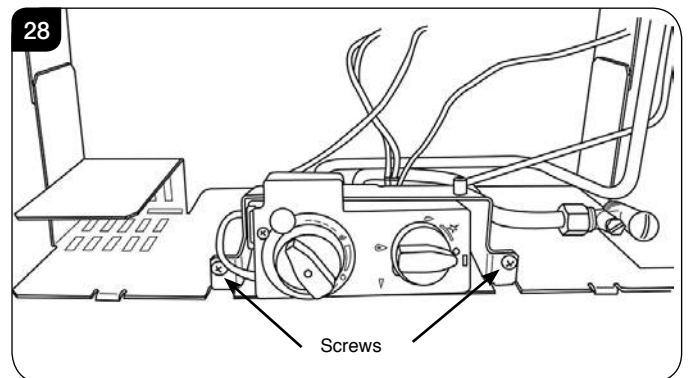

- 10.6 Slide the bracket slightly to the right and pull forward to access the valve connections.
- 10.7 Proceed to 10.11.

# Servicing Instructions - Replacing Parts

## CL8

Due to limited access to the pilot feed pipe connection at the pilot unit it is only necessary for this to be removed from the gas valve.

- 10.8 Remove the 2 screws at the front of the valve bracket, see Diagram 29.

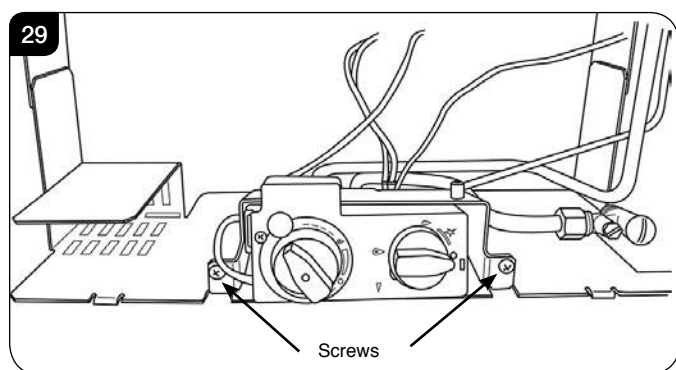

- 10.9 Slide the bracket slightly to the right and pull forward to access the valve connections.

- 10.10 Proceed to 10.11.

## All Models

- 10.11 Disconnect the 2 x 8mm and 1 x 4mm gas pipe fittings at the back of the gas valve, see Diagram 30 (A).

- 10.12 Disconnect the thermocouple, see Diagram 30 (B).

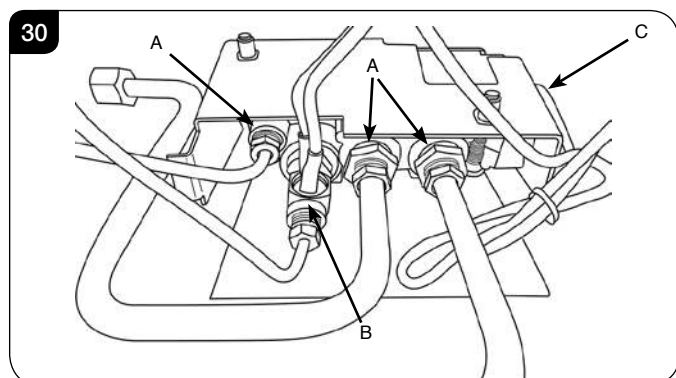

- 10.13 Disconnect the ignition lead from the gas valve, see Diagram 30 (C)

- 10.14 Remove the cover, see Section 9.3.

- 10.15 Undo the 2 screws securing the gas valve to the appliance and remove the valve.

- 10.16 Replace in reverse order.

- 10.17 Check all joints for gas leaks and check operation of the thermocouple and ignition lead.

## 11. Magnetic Safety Valve

- 11.1 Turn the gas supply off at the isolation device.

- 11.2 Undo the thermocouple connection from the back of the gas valve, see Diagram 31 (A).

- 11.3 Pull the sensor leads clear and remove the interrupter block, see Diagram 31 (B).

- 11.4 Undo the magnetic valve-retaining nut from the back of the control valve, see Diagram 31 (C).

- 11.5 Gently tap out the magnetic valve and replace with a new unit.

- 11.6 Replace the retaining nut and tighten.

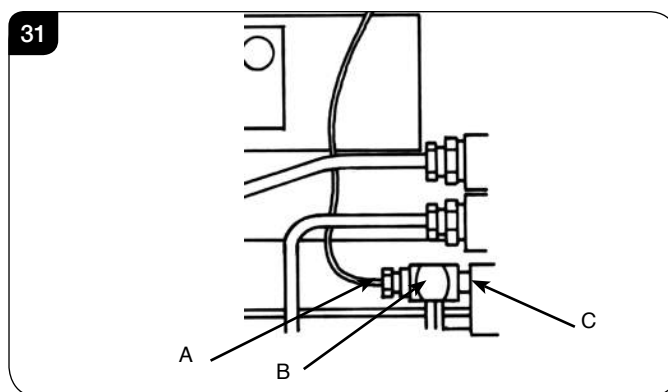

- 11.7 Reassemble the interrupter block and leads and secure the thermocouple connection in the rear of the gas control. (Do not overtighten).

- 11.8 Turn the gas supply on and check the entire pipework and valve joints for any leaks.

# Servicing Instructions - Replacing Parts

## 12. Main Injector

- 12.1 To remove the main injector turn off the gas supply at the isolation device.
- 12.2 Remove the main burner, see Section 5.
- 12.3 Undo the compression nuts from the feed pipe and the gas valve under the appliance.
- 12.4 Working from inside the firebox remove the lock nut from the injector, see Diagram 32.

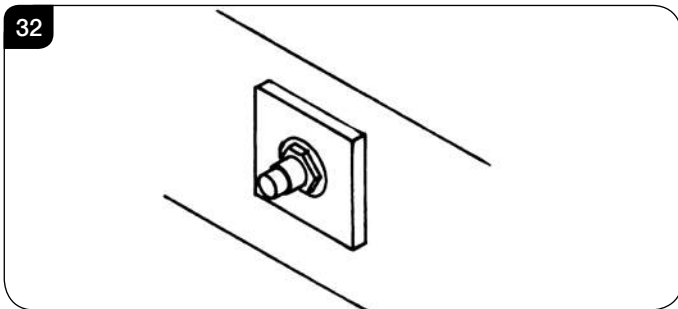

- 12.5 Extract the injector with the feed pipe from beneath the appliance.
- 12.6 Holding the injector with a spanner:
- 12.7 Undo the feed pipe. **Note the orientation of the injector.**
- 12.8 Re-assemble in reverse order.
- 12.9 Turn on the gas supply and check for leaks.

## 13. Flue Sure System

- 13.1 Open the door and remove the ceramics, placing them carefully to one side.
- 13.2 Undo the two screws in the back of the firebox and carefully withdraw the bracket, see Diagrams 33 and 34.

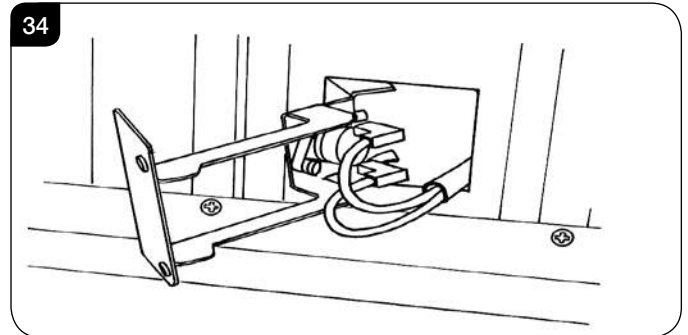
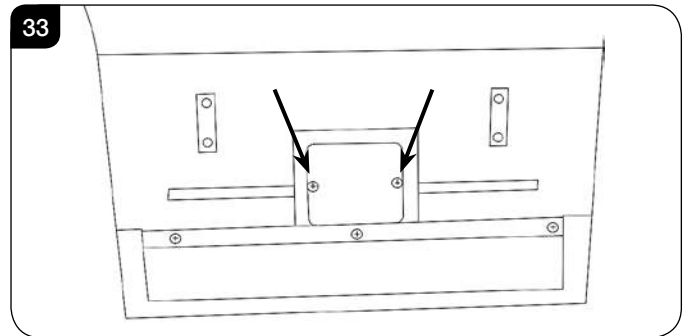

- 13.3 Disconnect the two sensor wires.
- 13.4 Undo the two retaining screws.
- 13.5 Remove the sensor, see Diagram 35.
- 13.6 **CL5 & CL8 only:** Remove the two plastic spacers, see Diagram 35.

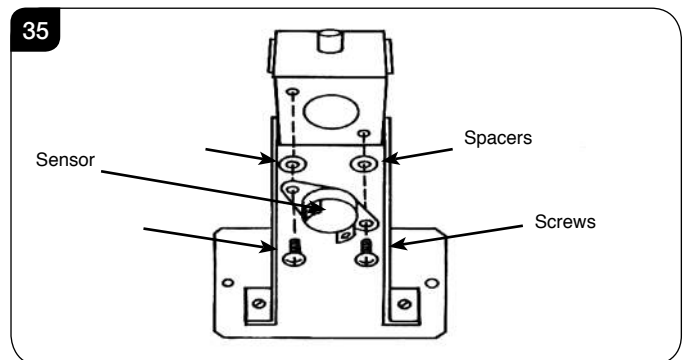

- 13.7 Refit the new sensor.  
**CL5 & CL8 only:** Ensure the plastic spacers are located between the bracket and the sensor.
- 13.8 Refit the leads.

- 13.9 Feed the cable back through the hole as you replace the bracket.  
When the bracket is located correctly it sits flush with the back panel without force. If not positioned correctly the bracket sits at an angle, see Diagram 36.

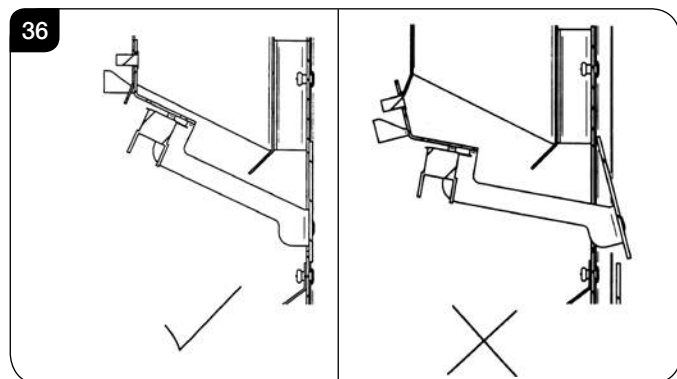

## 14. Primary Aeration Plate

**NOTE: Not all models have aeration plates. Please refer to the Technical Specification.**

- 14.1 To replace the primary aeration plate turn off the gas supply at the isolation device.  
14.2 Remove the burner, see Installation Instructions, Replacing Parts, Section 6.

### CL3 & CL5

- 14.3 Remove the fixing screw and slide the plate off the venturi.  
14.4 Replace with the correct size plate and secure with the screw. Ensure that the lower edge of the plate is located over the venturi flange, see Diagram 37.

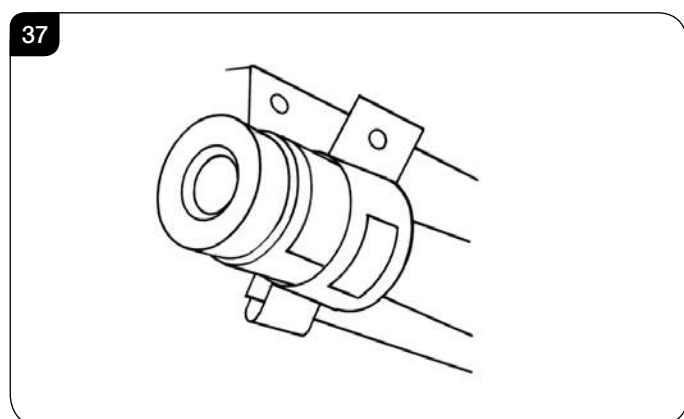

- 14.5 Reassemble in reverse order.  
**NOTE: Even if no aeration plate is required, the small screw must be replaced.**

### CL8

- 14.6 Remove the fixing nuts and slide the plate off the venturi.  
14.7 Replace with the correct size plate and secure with the nuts. Ensure the lower edge of the plate is located over the venturi flange, see Diagram 38.

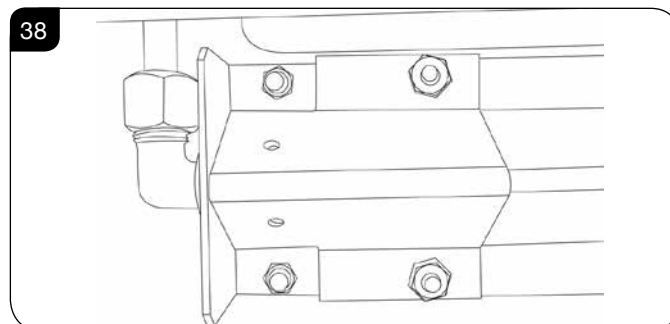

## 15. Changing Between Gas Types

A kit of parts is available for this - Contact your Gazco retailer for further information.

Always quote the Model number and Serial number when ordering any spare parts.

## 16. Control Upgrade

See Installation Instructions, Section 2.

# Servicing Instructions - Replacing Parts

## 17. Spare Parts List - CL3 Top Exit

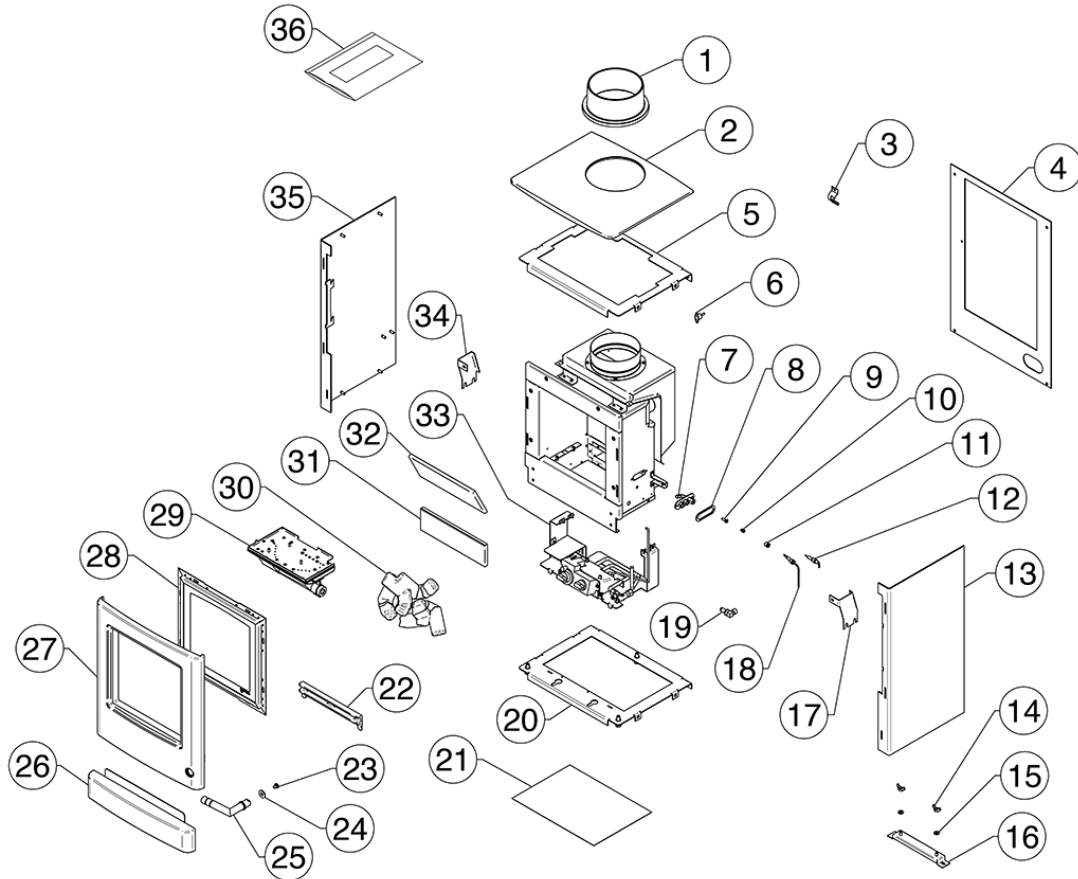

No.	Component	Part Code		
		Natural Gas	LPG	Quantity
1	Cast Flue Collar	CA0722		1
2	Cast Top	CA0725		1
3	Aeration Plate	GZ9708	GZ2016	1
4	Back Panel	GZ9762		1
5	Top Plate	GZ8689		1
6	Flue Sensor	EL0001		1
7	Pilot Burner Body	PI0051		1
8	Pilot Gasket	PI0052		1
9	Pilot Injector	PI0026	PI0015	1
10	Hook Olive	PI0013		1
11	Hook Nut	PI0014		1
12	Electrode	PI0053		1
13	RH Panel Assembly	GZ9653		1
14	M6 Wing Nut	C94225		2
15	1/4" Washer	FA0024		2
16	Stove Floor Fixing Bracket	GZ9744		1
17	Rear Firebox Bracket RH	GZ8715		1
18	Thermocouple	PI0010		1

No.	Component	Part Code		
		Natural Gas	LPG	Quantity
19	Injector	IN0040 Size 185	IN0071 Size 90	1
20	Base Plate	GZ8690		1
21	Instruction Manual	PR2032		1
22	Cast Log Retainer	CA0807		1
23	M6 x 8 CSK Pozi Screw	FA0063		1
24	M8 Washer	C92240		1
25	Door Handle Assembly	GZ9424		1
26	Control Cover Assembly	GZ9755		1
27	Main Door Assembly	GZ9754		1
28	Glass & Frame Assembly	GZ9751		1
29	Burner Assembly	GZ12756	GZ12757	1
30	Log Set	CE1559		1
31	Back Ceramic Panel	CE1560		1
32	Top Ceramic Panel	CE1561		1
33	Control Assembly	GZ12251		1
34	Rear Firebox Bracket LH	GZ8716		1
35	LH Panel Assembly	GZ9652		1
36	Embaglow Steel Fibre	GZ8471		1

Due to continual technical improvements please check with your Yeoman retailer for the most up to date parts lists.



# Servicing Instructions - Replacing Parts

## 17. Spare Parts List - CL3 Rear Exit

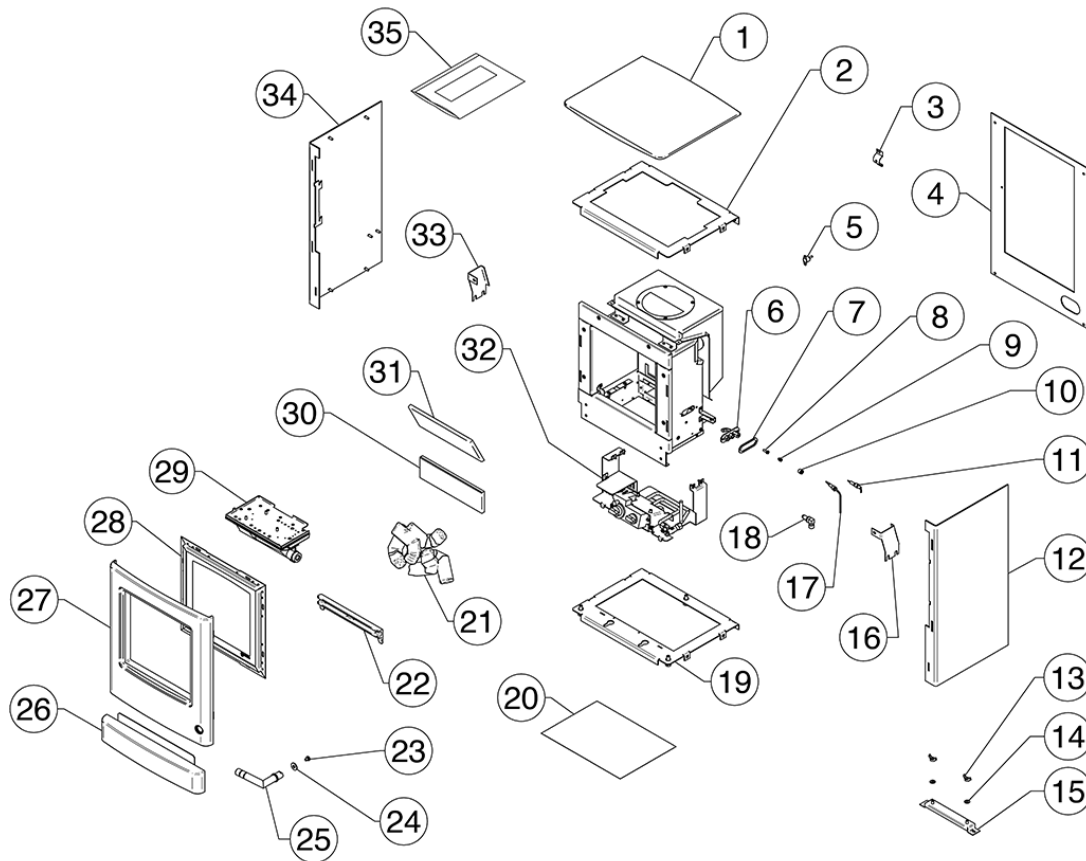

No.	Component	Part Code		
		Natural Gas	LPG	Quantity
1	Cast Top	CA0723		1
2	Top Plate	GZ8689		1
3	Aeration Plate	GZ9708	GZ2016	1
4	Back Panel	GZ9762		1
5	Flue Sensor	EL0001		1
6	Pilot Burner Body	PI0051		1
7	Pilot Gasket	PI0052		1
8	Pilot Injector	PI0026	PI0015	1
9	Hook Olive	PI0013		1
10	Hook Nut	PI0014		1
11	Electrode	PI0053		1
12	RH Panel Assembly	GZ9653		1
13	M6 Wing Nut	C94225		2
14	1/4" Washer	FA0024		2
15	Stove Floor Fixing Bracket	GZ9744		1
16	Rear Firebox Bracket RH	GZ8715		1
17	Thermocouple	PI0010		1
18	Injector	IN0040 Size 185	IN0071 Size 90	1

No.	Component	Part Code		
		Natural Gas	LPG	Quantity
19	Base Plate	GZ8690		1
20	Instruction Manual	PR2032		1
21	Log Set	CE1559		1
22	Cast Log Retainer	CA0807		1
23	M6 x 8 CSK Pozi Screw	FA0063		1
24	M8 Washer	C92240		1
25	Door Handle Assembly	GZ9424		1
26	Control Cover Assembly	GZ9755		1
27	Main Door Assembly	GZ9754		1
28	Glass & Frame Assembly	GZ9751		1
29	Burner Assembly	GZ12756	GZ12757	1
30	Back Ceramic Panel	CE1560		1
31	Top Ceramic Panel	CE1561		1
32	Control Assembly	GZ12251		1
33	Rear Firebox Bracket LH	GZ8716		1
34	LH Panel Assembly	GZ9652		1
35	Embaglow Steel Fibre	GZ8471		1

Due to continual technical improvements please check with your Yeoman retailer for the most up to date parts lists.

# Servicing Instructions - Replacing Parts

## 17. Spare Parts List - CL5 Top Exit

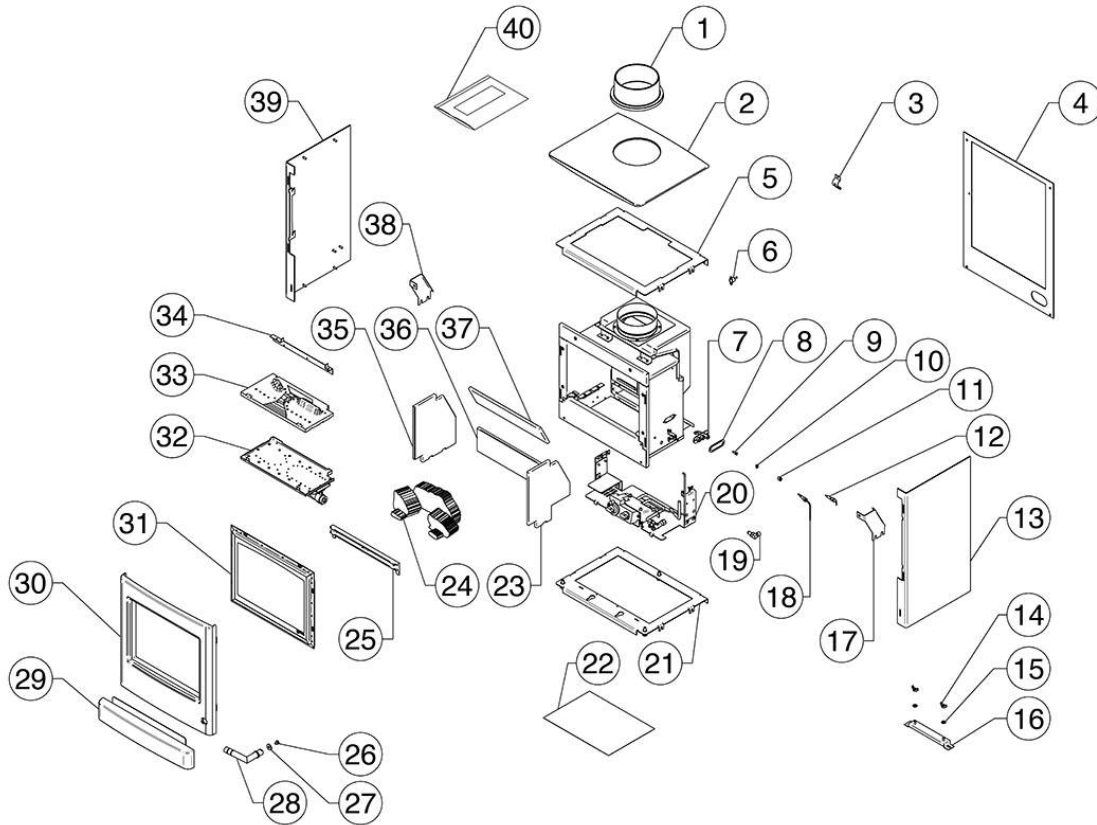

No.	Component	Part Code		
		Natural Gas	LPG	Quantity
1	Cast Flue Collar	CA0722		1
2	Cast Top	CA0731		1
3	Aeration Plate	GZ3270	GZ2025	1
4	Back Panel	GZ8650		1
5	Top Plate	GZ8651		1
6	Flue Sensor	EL0001		1
7	Pilot Burner Body	PI0051		1
8	Pilot Gasket	PI0052		1
9	Pilot Injector	PI0026	PI0015	1
10	Hook Olive	PI0013		1
11	Hook Nut	PI0014		1
12	Electrode	PI0053		1
13	RH Panel Assembly	GZ9655		1
14	M6 Wing Nut	C94225		2
15	1/4" Washer	FA0024		2
16	Stove Floor Fixing Bracket	GZ9744		1
17	Rear Firebox Bracket RH	GZ8710		1
18	Thermocouple	PI0011		1
19	Elbow Injector	IN0001 Size 260	IN0065 Size 102	1
20	Control Assembly	GZ12257		1

No.	Component	Part Code		
		Natural Gas	LPG	Quantity
21	Base Plate	GZ8652		1
22	Instruction Manual	PR2032		1
23	RH Ceramic Panel	CE1014		1
24	Log Set	CE0960		1
25	Cast Log Retainer	CA0744		1
26	M6 x 16 CSK Pozzi Screw	FA0053		1
27	M8 Washer	C92240		1
28	Door Handle Assembly	GZ9424		1
29	Control Cover Assembly	GZ9757		1
30	Main Door Assembly	GZ9756		1
31	Glass & Frame Assembly	GZ9753		1
32	Burner Assembly	GZ9712	GZ9713	1
33	Base Ceramic Panel	CE0997	CE1024	1
34	Rear Log Retainer	GZ9553	GZ9758	1
35	LH Ceramic Panel	CE1013		1
36	Back Ceramic Panel	CE1015		1
37	Top Ceramic Panel	CE1016		1
38	Rear Firebox Bracket LH	GZ8712		1
39	LH Panel Assembly	GZ9654		1
40	Embaglow Steel Fibre	GZ8471		1

Due to continual technical improvements please check with your Yeoman retailer for the most up to date parts lists.

# Servicing Instructions - Replacing Parts

## 17. Spare Parts List - CL5 Rear Exit

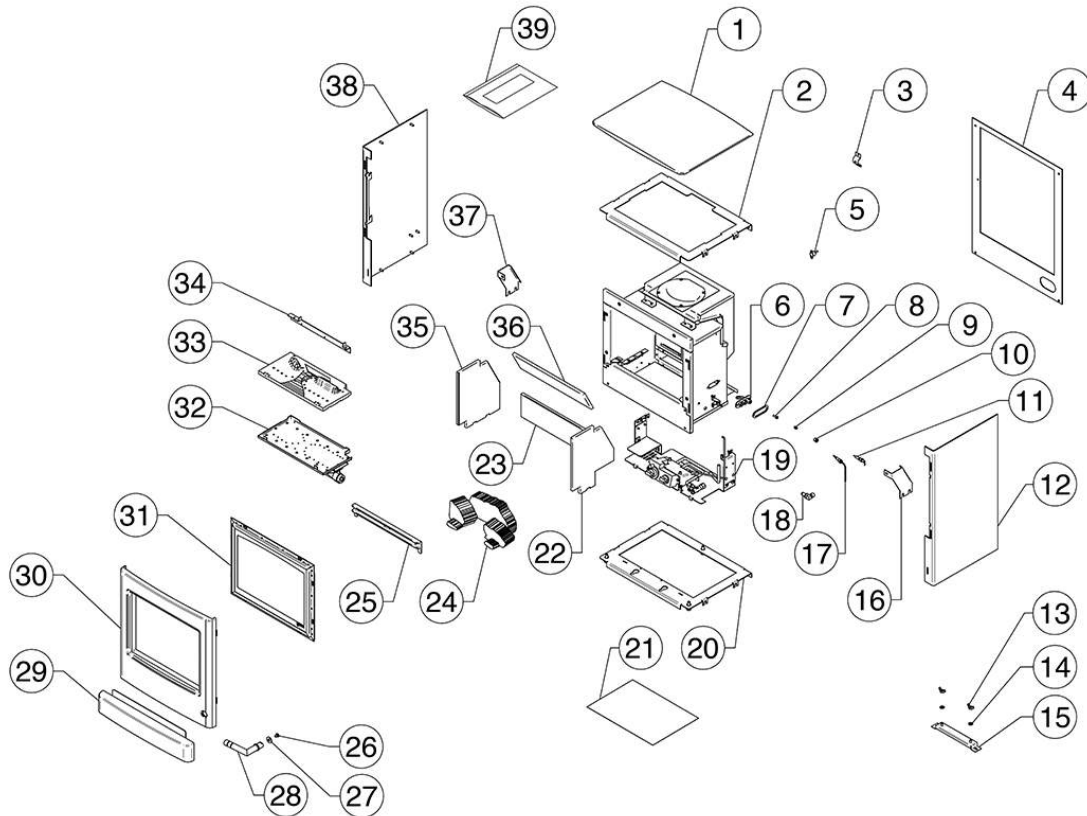

No.	Component	Part Code		
		Natural Gas	LPG	Quantity
1	Cast Top	CA0740		1
2	Top Plate	GZ8651		1
3	Aeration Plate	GZ3270	GZ2025	1
4	Back Panel	GZ8650		1
5	Flue Sensor	EL0001		1
6	Pilot Burner Body	PI0051		1
7	Pilot Gasket	PI0052		1
8	Pilot Injector	PI0026	PI0015	1
9	Hook Olive	PI0013		1
10	Hook Nut	PI0014		1
11	Electrode	PI0053		1
12	RH Panel Assembly	GZ9655		1
13	M6 Wing Nut	C94225		2
14	1/4" Washer	FA0024		2
15	Stove Floor Fixing Bracket	GZ9744		1
16	Rear Firebox Bracket RH	GZ8710		1
17	Thermocouple	PI0011		1
18	Elbow Injector	IN0001 Size 260	IN0065 Size 102	1
19	Control Assembly	GZ12257		1
20	Base Plate	GZ8652		1

No.	Component	Part Code		
		Natural Gas	LPG	Quantity
21	Instruction Manual	PR2032		1
22	RH Ceramic Panel	CE1014		1
23	Back Ceramic Panel	CE1015		1
24	Log Set	CE0960		1
25	Cast Log Retainer	CA0744		1
26	M6 x 16 CSK Pozi Screw	FA0053		1
27	M8 Washer	C92240		1
28	Door Handle Assembly	GZ9424		1
29	Control Cover Assembly	GZ9757		1
30	Main Door Assembly	GZ9756		1
31	Glass & Frame Assembly	GZ9753		1
32	Burner Assembly	GZ9712	GZ9713	1
33	Base Ceramic Panel	CE0997	CE1024	1
34	Rear Log Retainer	GZ9553	GZ9758	1
35	LH Ceramic Panel	CE1013		1
36	Top Ceramic Panel	CE1016		1
37	Rear Firebox Bracket LH	GZ8712		1
38	LH Panel Assembly	GZ9654		1
39	Embaglow Steel Fibre	GZ8471		1

Due to continual technical improvements please check with your Yeoman retailer for the most up to date parts lists.

# Servicing Instructions - Replacing Parts

## 17. Spare Parts List - CL8

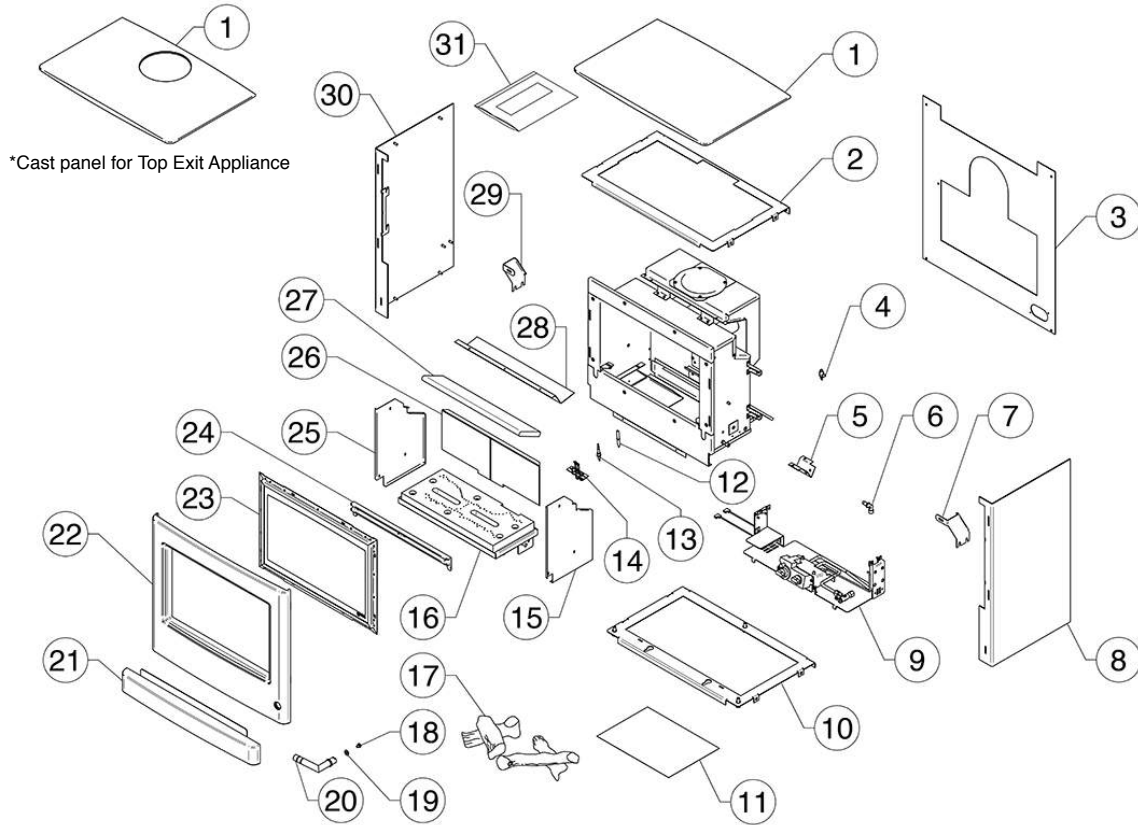

No.	Component	Part Code		
		Natural Gas	LPG	Quantity
1	Top Cast Panel - Top Exit	CA0735		1
	Top Cast Panel - Rear Exit	CA0745		1
2	Top Plate	GZ10907		1
3	Rear Panel	ME10906		1
4	Flue Sensor	EI0001		1
5	Aeration Plate - Top Exit	GZ10406		1
	Aeration Plate - Rear Exit	GZ10406	GZ11214	1
6	Injector	IN0076	IN0068	1
7	Rear RH Firebox Bracket	GZ10913		1
8	RH Panel Assembly	GZ10904		1
9	Control Assembly	GZ12259		1
10	Base Plate	GZ10905		1
11	Instruction Manual	PR2032		1
12	Thermocouple	PI0074		1
13	Electrode	PI0075		1
14	Pilot	PI0069	PI0070	1
15	RH Reflective Panel	GZ11015		1
16	Burner Assembly	GZ11001		1

No.	Component	Part Code		
		Natural Gas	LPG	Quantity
17	Log Set	CE1304		1
18	M6 x 16 CSK Pozzi Screw	FA0053		1
19	M8 Washer	C92240		1
20	Door Handle	GZ9424		1
21	Cast Plinth Assembly	GZ11063		1
22	Cast Door Assembly	GZ11062		1
23	Glass & Frame Assembly	GZ11045		1
24	Log Retainer	CA0765		1
25	LH Reflective Panel	GZ11014		1
26	Rear Liner Panel	CE1311		1
27	Top Liner Panel	CE1312		1
28	Top Baffle	GZ11019		1
29	Rear LH Firebox Bracket	GZ10912		1
30	LH Panel Assembly	GZ10903		1
31	Embaglow Steel Fibre	GZ8471		1

Due to continual technical improvements please check with your Yeoman retailer for the most up to date parts lists.

# Servicing Instructions - Replacing Parts

## 17. Spare Parts List - Control Assembly

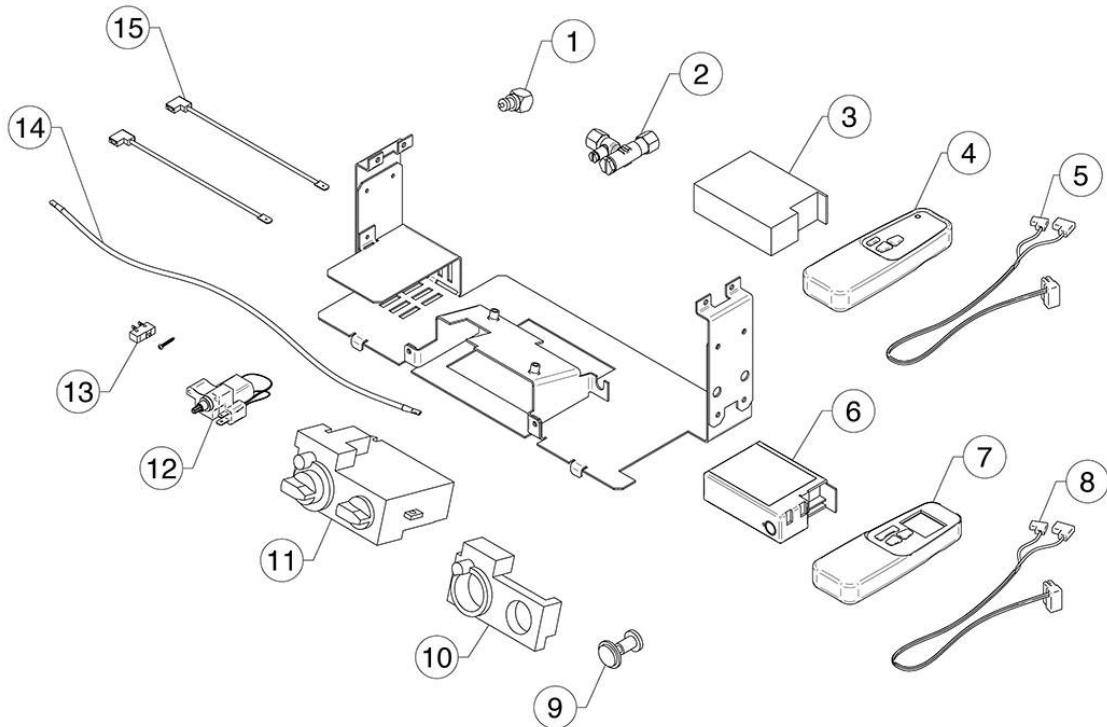

No.	Component	Part Code	Quantity
1	Interrupter Block	GC0026	1
2	Inlet Isolation Valve	GC0095	1
3	Standard Receiver	EL0235	1
4	Standard Handset	EL0239	1
5	Standard Receiver Cable	EL0237	1
6	Thermostatic Receiver	EL0236	1
7	Thermostatic Handset	EL0240	1
8	Thermostatic Receiver Cable	EL0238	1
9	Mag. Unit	GC0166	1
10	Control Valve Cover	GC0087	1
11	Control Valve	GC0088K	1
12	Geared Motor	EL0234	1
13	Micro Switch & Screw	EL0241	1
14	Ignition Lead	GC0090	1
15	Flue Sensor Lead	EL0064	2

Due to continual technical improvements please check with your Yeoman retailer for the most up to date parts lists.

# Service Records

**1ST SERVICE**

Date of Service .....  
Next Service Due .....  
Signed .....  
Retailer's Stamp/Gas Safe Registration Number

**3RD SERVICE**

Date of Service .....  
Next Service Due .....  
Signed .....  
Retailer's Stamp/Gas Safe Registration Number

**5TH SERVICE**

Date of Service .....  
Next Service Due .....  
Signed .....  
Retailer's Stamp/Gas Safe Registration Number

**7TH SERVICE**

Date of Service .....  
Next Service Due .....  
Signed .....  
Retailer's Stamp/Gas Safe Registration Number

**9TH SERVICE**

Date of Service .....  
Next Service Due .....  
Signed .....  
Retailer's Stamp/Gas Safe Registration Number

**2ND SERVICE**

Date of Service .....  
Next Service Due .....  
Signed .....  
Retailer's Stamp/Gas Safe Registration Number

**4TH SERVICE**

Date of Service .....  
Next Service Due .....  
Signed .....  
Retailer's Stamp/Gas Safe Registration Number

**6TH SERVICE**

Date of Service .....  
Next Service Due .....  
Signed .....  
Retailer's Stamp/Gas Safe Registration Number

**8TH SERVICE**

Date of Service .....  
Next Due .....  
Signed .....  
Retailer's Stamp/Gas Safe Registration Number

**10TH SERVICE**

Date of Service .....  
Next Service Due .....  
Signed .....  
Retailer's Stamp/Gas Safe Registration Number











**Yeoman Limited, Osprey Road, Sowton Industrial Estate, Exeter, Devon, England EX2 7JG**  
**Technical Customer Services: (01392) 261950 Fax: (01392) 261951**  
**E-mail: [yeoman@gazco.com](mailto:yeoman@gazco.com)**

A member of the Stovax Group  
E & O E