

# WOODFORD Stove **Instructions**

---



The  
**Woodford**  
Collection

**PLEASE RETAIN THIS GUIDE FOR FUTURE REFERENCE**

EN 13240:2011 +A2:2004

---

**Booklet** 723 Rev 02

ISSUE DATE : 27/07/2018



# WOODFORD Stove **Instructions**

---

## Woodford Stove Collection

Congratulations on the purchase of your new stove!

More than 30 years of experience has been put into the development of your stove to ensure ultimate performance and years of trouble free use and enjoyment. Every detail of your stove has been carefully designed and engineered which is why we are so confident in the reliability of our products.

Your stove is built to the highest standard of craftsmanship using the best materials and the most modern equipment available. It is a highly efficient and sophisticated piece of machinery and when properly installed and operated it should provide a lifetime of heating satisfaction.

Should you have any questions about your stove which are not covered by this manual, please contact the your retailer in your area or visit our website : [www.flue-ducting.co.uk](http://www.flue-ducting.co.uk), which offers a wealth of information on how to care for and get the best from your stove.

Please ensure that you read these instructions in full and understand them before operating your stove.

Flue & Ducting has a policy of continuous product development and therefore we reserve the right to amend specifications without prior notice. Due to printing cycles, items or options may be described before they are generally available or after they have ceased. Please check with your retailer or dealer if you are unsure about any aspect of your stove, its installation or correct use.

# WOODFORD Stove Instructions

## Contents

<b>1 Identifying your stove</b>	
1.1 Identifying parts & terminology of your stove—External.....	5
1.2 Identifying parts & terminology of your stove—Internal .....	6
<b>INSTALLATION GUIDE</b>	
<b>2 Warnings</b>	
2.1 Important Warnings .....	7
<b>3 Health &amp; Safety</b>	
3.1 Health and Safety Practice.....	7
<b>4 Installation Requirements</b>	
4.1 Hearth & Recesses.....	8
4.2 Combustible Materials.....	8
4.3 Air For Combustion.....	9
<b>5 Flue &amp; Chimneys</b>	
5.1 Requirements.....	10
<b>6 Installing The Stove</b>	
6.1 Removing The Door.....	11
6.2 Removing The Throat Plate & Liners.....	11
6.3 Fitting The Spigot Outlet.....	11
6.4 Fitting The Hot Plate (Blanking Plate).....	12
6.5 Connecting The Spigot Outlet To The Flue System.....	12
6.6 Firebox Liner Panels.....	12
6.7 Optional Accessories.....	12
6.8 Smoke Control Areas (The Clean Air Act 1993 & Smoke Control Areas).....	13
<b>7 Commissioning The Stove</b>	
7.1 Checklist.....	14
<b>USER GUIDE</b>	
<b>8 Warnings</b>	
8.1 Important Warnings.....	15
8.2 Health & Safety.....	16
8.3 Smoke Control Areas (The Clean Air Act 1993 & Smoke Control Areas).....	16
<b>9 Recommended Fuels</b>	
9.1 Wood.....	17
9.2 Mineral Smokeless Fuel (Solid Fuel) .....	17

# WOODFORD Stove Instructions

---

<b>10 Before You Start</b>	
10.1 Pointers Before Use .....	18
<b>11 Air Inlet Controls</b>	
11.1 Air inlet .....	19
11.1.1 Primary air control location.....	19
11.1.2 Primary air control .....	20
11.1.3 Secondary air control.....	20
11.1.4 Tertiary air .....	21
<b>12 Lighting Your Stove</b>	
12.1.1 Smoke control areas .....	22
12.1.2 Fuel overloading .....	22
12.1.3 Operation with door left open .....	22
12.1.4 Dampers / Air controls left open .....	22
12.2 Burning wood .....	22
12.3 Burning solid fuel.....	23
12.4 Warning - Fume / Smoke emissions .....	24
12.5 Refuelling on to a low fire bed .....	24
12.6 Smoke Control Area.....	25
12.7 Typical burn for nominal output .....	25
<b>13 Further Information For All Stove Owners</b>	
13.1 Reduced burning (Slow combustion).....	26
13.2 Over firing.....	26
13.3 Chimney fires.....	26
13.4 Periods of non-use (Summer months).....	26
13.5 Riddling the firebox .....	27
13.6 Ash removal .....	27
13.7 Replacement parts.....	28
13.8 Classification.....	28
13.9 Adverse weather conditions.....	28
13.10 Door glass.....	29
13.11 Fire door handle / riddle handle.....	29
<b>14 Care for your stove</b>	
14.1 Adjusting the door hinges .....	30
14.2 Liners / firebricks .....	30
14.3 Throat plate.....	30
14.4 Fire door seal .....	31
14.5 Cracked glass .....	31
14.6 Chimney / flue sweeping .....	31
<b>15 Further resources / information</b>	
15.1 Information.....	31
15.2 Specifications .....	31
<b>16 Guarantee</b>	
16.1 Guarantee .....	32
16.2 Terms and Conditions .....	32
16.3 General .....	33
<b>Technical data</b> .....	34

# WOODFORD Stove Instructions

## 1 Identifying your stove

### 1.1 Identifying parts & terminology of your stove—*External*

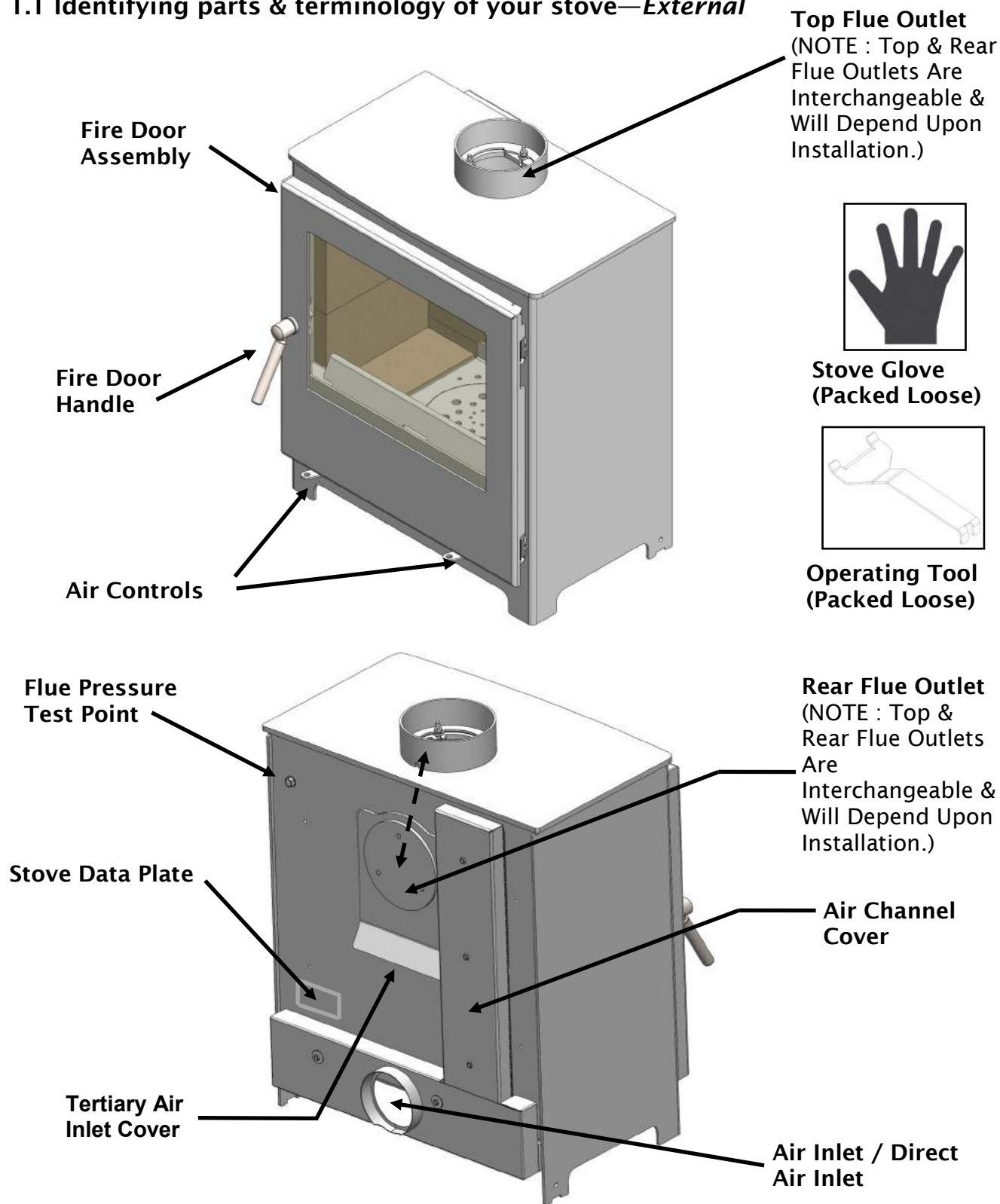

# WOODFORD Stove Instructions

## 1.2 Identifying parts & terminology of your stove—*Internal*

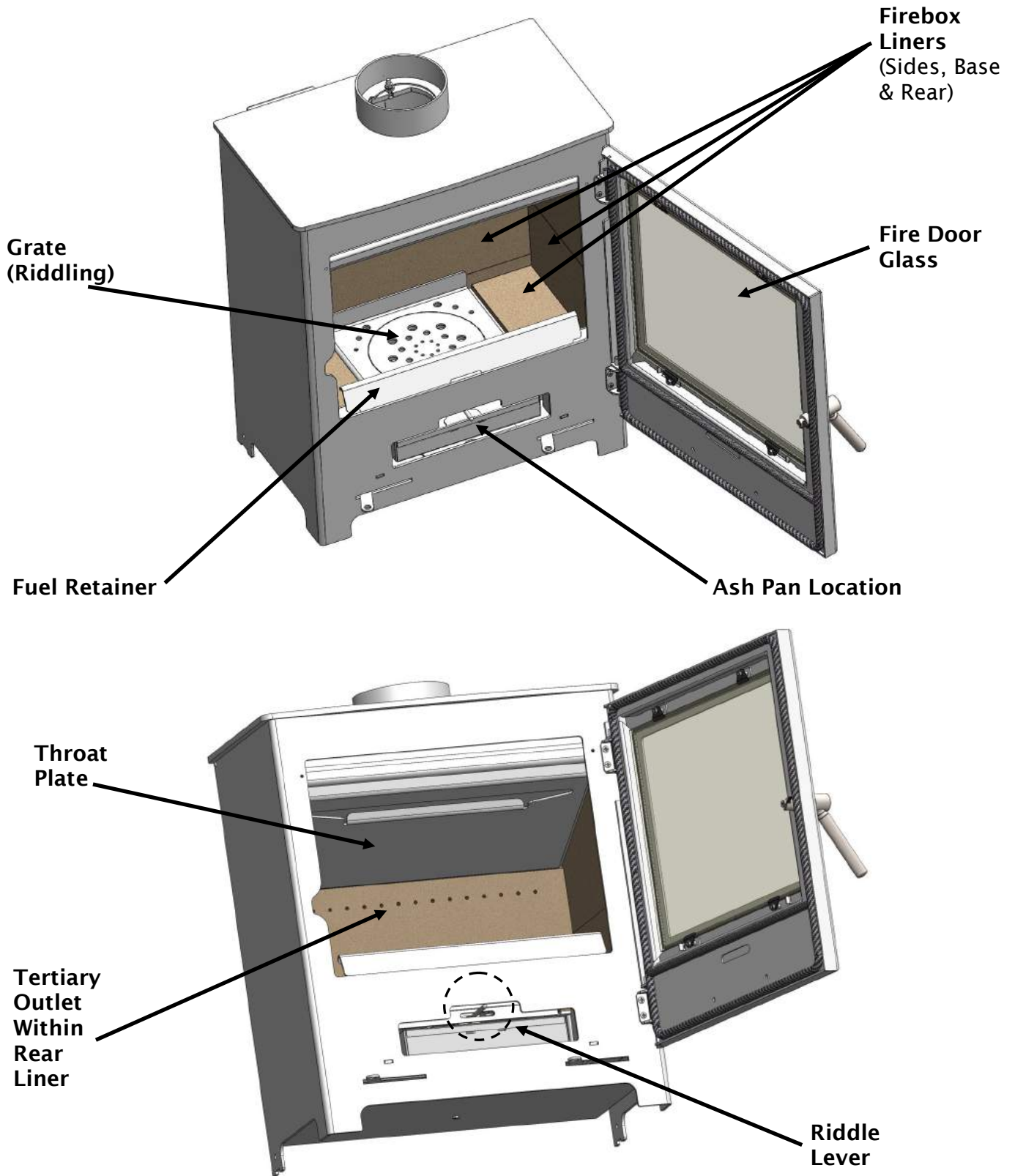

# INSTALLATION GUIDE

## 2 Warnings

### 2.1 Important Warnings

It is a LEGAL REQUIREMENT that the installation of all new or replacement, wood or solid fuel heating appliance, obtain building control approval from your local authority or the installation work must be carried out through a government approved competent persons scheme. A list of all competent person schemes can be found :  
<https://www.gov.uk/guidance/competent-person-scheme-current-schemes-and-how-schemes-are-authorised>

All local regulations, including those referring to National & European standards, need to be complied with when installing the appliance.

This stove should not be installed into a chimney or flue system that serves other heating appliances.

Any manufacturers instructions must not be taken as overriding statutory requirements.

Flue & Ducting Ltd will not be responsible for any consequential or incidental loss or injury however caused.

Any further warnings in this document will be marked out in a box such as this one.  
Ignoring the warnings, could lead to damage / injury to persons and / or property.

## 3 Health & Safety

### 3.1 Health & Safety Practice

Before any installation work is undertaken consideration must be given to the Health and Safety at Work Act 1974. Safe working practices should be followed at all times.

Please consult health and safety guidelines for advice on handling heavy and/or large items.

During installation ensure that adequate precautions are taken to avoid unnecessary risk to yourself or any householder.

The danger from the caustic nature of fire cement, should be avoided by using these accepted methods: Wear gloves when handling fire cement. Wear goggles when chiselling or looking up chimneys.

This stove contains no asbestos. If there is a possibility of disturbing any asbestos in the course of the installation then please seek specialist guidance and use appropriate protective equipment.

# INSTALLATION GUIDE

## 4 Installation Requirements

### 4.1 Hearths and Recesses

The stove should be installed on a surface with adequate load bearing capacity. If the existing construction does not meet this prerequisite, suitable measures (e.g. load distributing plate) should be taken to achieve it. Please pay particular attention when examining existing building work for suitability to meet the following requirements.

When installing a stove, hearths should have a sufficiently flat surface to allow a firm seating surface for the stove body to be positioned during its installation. Stonework, uneven bricks, loose tiles etc., may need further work to ensure that this can be achieved.

The stove should be installed on a non-combustible surface not less than 12mm thick (conforming to Building Regulations unless otherwise specified) of suitable load bearing capacity and heat resistance. Allowances should be made for the expansion and contraction of any materials which are fitted up to and near the appliance.

If required, the dimensions of any constructional hearth for all stoves should project at least 500mm forward of the front of the appliance and 150mm at the sides. The surface of the hearth should be free of combustible materials.

The superimposed hearth for all installations should project at least 225mm forward from the front of the appliance and 150mm either side of the edge of the appliance.

In most buildings with solid concrete or stone floors, the requirement will be met by the floor itself, but mark the hearth to ensure floor coverings are kept well away or use different levels to mark the hearth perimeter.

Please be aware that hot air can cause staining above the fire in a similar fashion to walls above radiators.

To help prevent this and cracking we recommend that any plaster above the fire should be fitted with reinforcing expanding mesh for at least 220mm above, and the full width of the fire. You should also use a suitably heat resistant plaster which should be allowed sufficient time to fully dry before using the stove or cracking is likely to occur.

### 4.2 Combustible Materials

Please view the product sheet or data plate which accompanied your stove for specific minimum distances to combustible measurements.

Ideally, adjacent walls should be of suitable non-combustible construction, preferably brickwork.

In large fireplaces take care that any supporting beam is protected by a 13mm sheet of heat resistant fire board spaced 12mm off the surface with strips of non-combustible material. Make sure that there is a gap between an un-insulated flue system and any combustible material. This gap must be at least 3X the outside diameter of the flue pipe, or 1.5X the flue diameter to non combustible surfaces. Please consult the flue manufacturers specification for insulated flues.



# INSTALLATION GUIDE

## 4.3 Air For Combustion

All stoves require ventilation to burn safely and correctly. There are a number of requirements that need to be met when installing a stove, for example, allowing for the permeability of the house (air permeability is the general seepage of air into the house via air vents, doors and windows etc.)

There must always be a permanent means of providing air for combustion into the room in which the stove is installed. Air starvation will result in poor flue draw and may cause smoke to leak into the room.

For all installations it is recommended that a permanent vent with a total free area of at least 550mm<sup>2</sup> for every kW above 5kW should be connected directly to the outside air. Installations in properties built after 2008 should have their vent increased by a further 330mm<sup>2</sup> for each of the first 5kW. Alternatively, this air can be supplied through an external wall of an adjacent room, which itself has to be connected to the room the appliance is installed by a permanent vent of the same size.

Note: If the appliance is fitted with a draught stabiliser (or if one is fitted to the flue pipe or chimney in the same room as the appliance) then the permanent air entry opening (or openings) should be increased by 300mm<sup>2</sup> for each kW of rated output up to 5kW and an additional 850mm<sup>2</sup> for each kW output over 5kW.

If there is more than one appliance in the property then each appliance must be supplied with adequate combustion air so that all appliances can be lit simultaneously.

The positioning of any air vent must be so that it cannot be liable to blockage or obstruction. Ideally it should also be positioned where it is unlikely to cause a cold draught. It should not be positioned in the fireplace recess.

For more detailed guidelines on required ventilation sizes please refer to the Document J Building Regulations (Combustion Appliances) at the [www.planningportal.gov.uk](http://www.planningportal.gov.uk) website.

If you plan to use an external air supply on a stove, (sometimes referred to as direct air supply) then the rear connection spigot can be used to affix the incoming air supply in a suitable 100mm inside diameter flexible duct (see Fig.1).

Please note, the appliance is classed a partially sealed and the supply from the air inlet duct, feeds both the primary and secondary air controls.

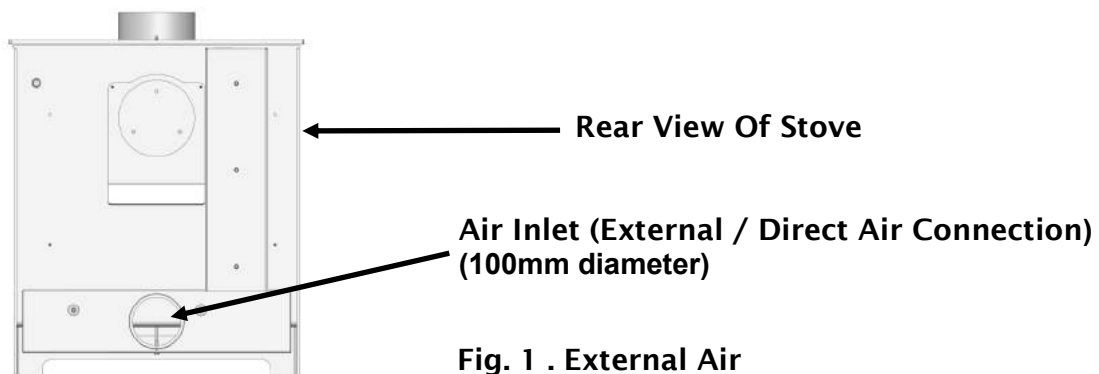

Fig. 1 . External Air

# INSTALLATION GUIDE

## 5 Flue And Chimneys

### 5.1 Requirements

The stove must be connected to a suitable and efficient flue so that products of combustion (fumes) from the stove are expelled to the outside air. Please remember that chimney draught is dependent on four main factors :

- Flue gas temperature
- Flue height
- Flue size
- Flue terminal

To ensure a good up draught it is important that the flue gases are kept warm and that the flue size suits the stove. The termination of the outlet at the top of the flue also needs to comply with Building Regulations. The minimum effective height of the flue must be at least 4.5 metres from the top of the stove to the top of the flue outlet. When warm the flue draught should be between 0.1 to 0.2mb.

The draw of a chimney / flue can vary in different weather conditions and the customer should be made aware of this. Failure to correct an over-drawing flue will invalidate the warranty.

A chimney may comply with regulations but could still be subject to down draught and similar problems. A chimney terminating above the ridge level is generally less likely to suffer such problems.

If a new chimney is being provided it should fully comply with the relevant Building Regulations that specify the requirements for solid fuel burning installations. Suitable types of chimney include the following :

- Masonry Chimney : Built with clay or concrete liners, or a chimney block system meeting Building Regulations. These types of chimneys should be installed in accordance with the Building Regulations and BS EN 15287-1:2007.
- Factory Made Insulated Chimney : Complying with BS 4543:Part 2 (often called Class 1 prefabricated metal chimney). These types of chimneys should be installed in accordance with Building Regulations and BS EN 15287-1:2007.

Due to the gradual introduction of European Chimney Standards chimneys will be specified according to their performance designation as defined in BS EN 1443 that covers the General Requirements for chimneys. The minimum performance designation required for use with solid fuel burning stoves is T450 N2 S D3.

The flue and chimney installation must be carefully checked by a competent person before fitting the stove to ensure it is suitable and will work safely.

If the chimney is old (i.e.: built of brick or stone without a liner) or being opened up for reuse additional checks and smoke testing as described in Appendix E of the Approved Document J 2010 Edition should also be carried out to ensure the flue and chimney are in good operating condition.

# INSTALLATION GUIDE

Check the existing flue is in good condition with suitable access for collection and removal of debris.

It is also important that suitable flue pipe (recommended at least 600mm in length) complying with the Building Regulations is used to connect the stove to the flue in the chimney. Suitable access should be provided into the flue for regular inspection and sweeping of the flue ways.

The installer should comply with Building Regulations requirements in respect of providing a Notice Plate giving details on the chimney, flue lining, hearth and fireplace installation.

Chimneys should be as straight as possible. Horizontal runs should be avoided except where the rear outlet of the appliance is used, in which case the horizontal section should not exceed 150mm in length. If necessary a combination of 45° and 90° bends can be used, as long as the sum of their angles is not greater than 180° in total.  
IE: four x 45° bends or two x 45° and a 90° bend.

If the stove appears to be working hard but produces very little output to the room it is likely that excess draw is present in the chimney, and that heat is being sucked out of the appliance and up the chimney. If this is the case we recommend the fitting of a draught stabiliser in preference to a flue damper, in the interest of safety and efficiency.

## 6 Installing The Stove

To make the stove easier to manoeuvre (and safer) we recommend you remove the following parts which can then be refitted when the stove is in its final position:

Liners, Door (To help prevent the glass from breaking), Operating Tool, Ash pan, Throat Plate & Fuel Retainer.

### 6.1 Removing the door

Open the door so that it's perpendicular to the stove body and then carefully lift the stove door upwards off its hinges. To replace the door reverse the instructions above.

### 6.2 Removing the throat plate and liners

The throat plate rests on the rear liner and ledge within the upper edge of the door aperture. Push up on the mid part of the throat plate with the palm of one hand. With the other, remove the upper rear liner and then lower the throat plate forward from the ledge. Diagonally twist the throat plate to allow removal through the door aperture. The remaining liners, can now be removed. Again reverse procedure for refitting.

### 6.3 Fitting The Flue Spigot Outlet

The flue spigot outlet is found packed inside the appliance. Depending upon the particular installation, the flue spigot outlet can either be fitted to the top or rear outlet. The fitting of the spigot is affixed to the stove body using the 3no. M6 Square cup bolts, washers and nuts supplied. Note, ensure that the rope seal is in place before fully tightening the fixings. A very thin layer of fire cement can also be applied to the mating surfaces.

# INSTALLATION GUIDE

## 6.4 Fitting The Hot Plate (Blanking Plate)

The hot plate or sometimes referred to as a blanking plate, will be supplied fitted to the rear outlet of the stove. Again this can be fitted to either outlet on the appliance and is dependent upon the installation requirements.

Fitting is simply done using the supplied M6 nuts and washers (no bolts are required as studs are factory fitted to the hot plate disc). Again fire cement can be used in conjunction with the self adhesive rope seal.



### IMPORTANT INFORMATION

When fitting the flue spigot & hot plate, always ensure that the rope seal is fitted.

Failure to do so, could lead to exhaust fume leakage into the property and potential carbon monoxide poisoning.

## 6.5 Connecting The Spigot Outlet To The Flue System

The flue pipe must be fitted inside the outlet spigot as shown in Figure 2.

Failure to do so could result in the spillage of condensation running down the flue.

Fire cement should be used to create an airtight seal between the flue and spigot.

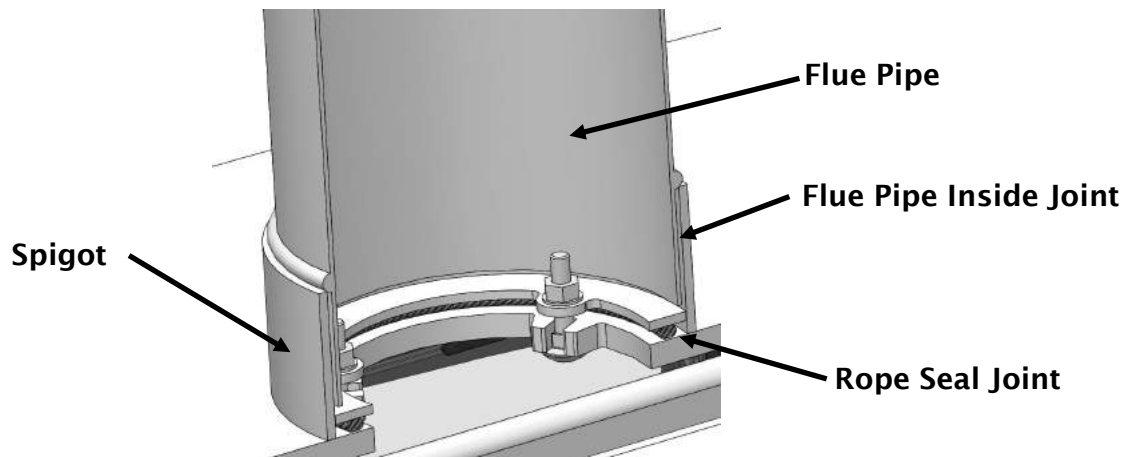

Fig. 2 . Flue & Spigot Fitting

## 6.6 Firebox Liner Panels

All models of the Woodford stove collection, use firebox liner panels to the side, back and either side of the rotating grate to the base of the appliance.

The stove will be delivered with the liner panels in situ, however it may be easier to remove these during installation.

## 6.7 Optional Accessories

Further optional extras, such as a rear heat shield, solid fuel burning kit etc. are available via your retailer or dealer.

# INSTALLATION GUIDE

## 6.8 Smoke Control Area (The Clean Air Act 1993 & Smoke Control Areas)

If the stove is to be installed in a designated Smoke Control Area (further information can be found via <https://www.gov.uk/smoke-control-area-rules> ) then the secondary air lever must be fitted with a restrictor plate to prevent total closure of the secondary air control. The plate is supplied with the stove and can be fitted as :

- Remove the 2no. Fixings securing the direct air plate. Withdraw this plate from the stove and store safely together with the fixing screws.
- Carefully lay the stove onto the rear face.
- Locate the secondary air control slider (LH side of stove when looking at the front).
- Remove the front 2no. M5 nuts securing the control to the body of the stove.
- Locate the restrictor plate over these exposed studs, ensuring the protruding up-turn fold is facing the air control.
- Replace the 2no. M5 nuts.
- Check the operation of the secondary control lever, you will now see the control will not fully close and thus allows a minimum free air flow into the stove.
- Carefully move the stove into an upright position.
- Replace the direct air plate and fixings.

### NOTE :

The minimum air control setting is governed in manufacture to meet the requirements of Smoke Control exemption and as a result the appliance will **NOT** shut down completely when in the minimum air position setting.

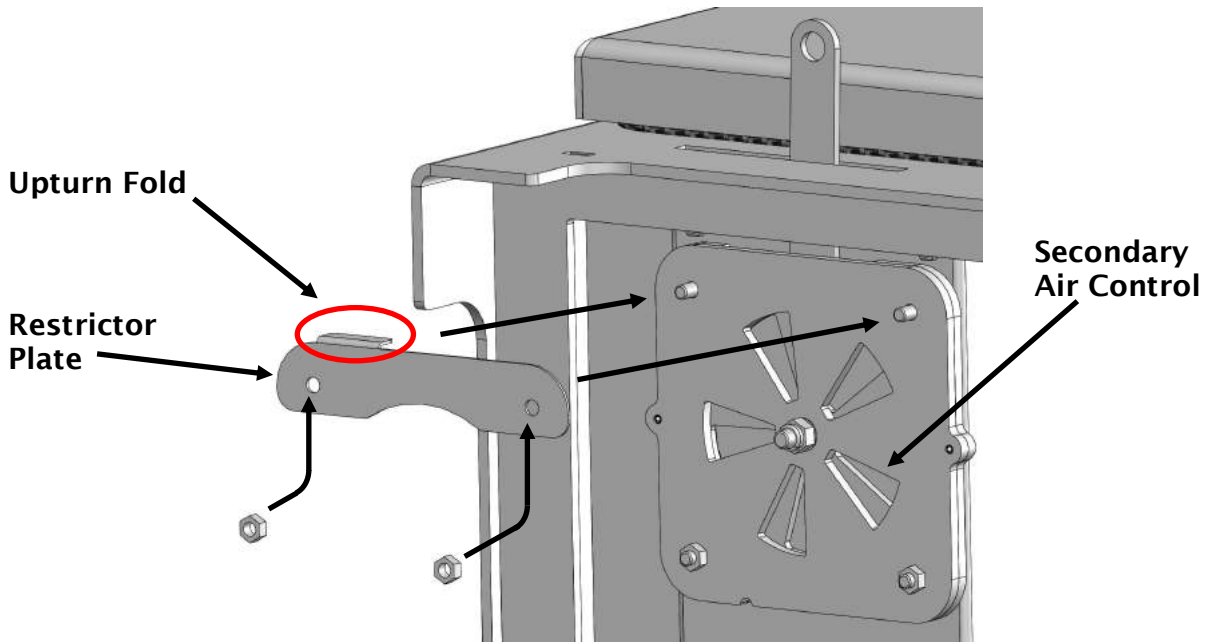

## IMPORTANT INFORMATION

Removal or modification of the restrictor plate is illegal when the appliance is installed in a smoke exemption area and doing so may result in prosecution and fine.

# INSTALLATION GUIDE

## 7 Commissioning the stove

### 7.1 Checklist

Before handing over the installation to the customer it is a requirement under Document J (of the Building Regulations for England and Wales) that the appliance is lit and the functioning of the chimney system is checked for satisfactory operation.

- Be sure that the chimney is operating and all smoke and fumes are vented to the atmosphere through the chimney terminal.
- Check all joints and seals.
- Clean the outside of the cold appliance with a lint free cloth or shoe brush to prevent any stains becoming burnt on.
- Check the flue draught which should read 10 - 20pa, or 0.1 - 0.2 mbar. Consult a suitably qualified person who will have the knowledge and equipment to perform a test.
- For a registered Competent Persons scheme (such as those referred to at [www.gov.uk/building-regulations-competent-person-schemes](http://www.gov.uk/building-regulations-competent-person-schemes) ), please complete a Certificate of Compliance, which is used for checking and reporting the installation as imposed by the Government. Otherwise please ensure the installation is approved by your local building control officer.
- Ensure a Carbon Monoxide alarm is fitted. This must be between 1m to 3m from the appliance, and approximately 150mm below the ceiling level.
- A fireguard conforming to BS 8423:2002 should be used in the presence of children or infirm people.
- A notice plate should be provided containing information on the performance characteristics of the hearth, fireplace, flue or chimney.
- Explain the following to the customer:
  - How to operate the riddling mechanism and air control lever.
  - The importance of an adequate air supply to the room.
  - The importance of regularly having the chimney swept / inspected.
  - That a protective glove should be used when operating the stove.
  - How changes in the weather can effect the performance of the stove.
  - Using the correct fuels.

# USER GUIDE

## 8 Warnings—



## IMPORTANT INFORMATION

### 8.1 Important Warnings

It is a LEGAL REQUIREMENT that the installation of all new or replacement, wood or solid fuel heating appliance, obtain building control approval from your local authority or the installation work must be carried out through a government approved competent persons scheme. A list of all competent person schemes can be found :  
<https://www.gov.uk/guidance/competent-person-scheme-current-schemes-and-how-schemes-are-authorised>

Any manufacturer's instructions must not be taken as overriding statutory requirements.

All Woodford stoves MUST NOT be connected to a shared flue system.

Please Note: Classification of these appliances is for intermittent use only.

Do not use aerosol sprays or any other flammable materials near the appliance when in use.

Do not use the appliance as an incinerator.

Use only recommended fuels, STRICTLY NO unsuitable and non recommended fuels or materials or liquid fuels allowed.

Pure petroleum coke or Bituminous house coal must NOT be burned in this appliance. The use of these fuels will invalidate the appliance guarantee.

Please ensure that the air inlet vent grills to the dwelling are not obstructed or liable to be blocked.

Caution must be exercised during operation of the appliance as both internal and external surfaces will be hot to touch, use the stove mitten provided when the appliance is in operation.

A fireguard conforming to BS 8423:2002 should be used in the presence of children or elderly people.

Always observe the distances to combustible materials as stated on the appliance data plate and in the technical data section of this manual. Ensure no soft furnishings or combustible materials are susceptible to heat radiating from the appliance.

Under NO circumstances should the stove be operated for extended periods with the main fire door open. This will result in an over firing situation and will lead to severe damage to the stove and flue system.

Ignoring the warnings could lead to damage/injury to persons and/or property.

Flue & Ducting Ltd will not be responsible for any consequential or incidental loss or injury however caused.

# USER GUIDE

---

## 8.2 Health and Safety

Please consult health and safety guidelines for advice on handling heavy and / or large items.

## 8.3 Smoke control areas (The Clean Air Act 1993 & Smoke Control Areas)

Under the Clean Air Act local authorities may declare the whole or part of the district of the authority to be a smoke control area. It is an offence to emit smoke from a chimney of a building, from a furnace or from any fixed boiler if located in a designated smoke control area. It is also an offence to acquire an “unauthorised fuel” for use within a smoke control area unless it is used in an “exempt” appliance (“exempted” from the controls which generally apply in the smoke control area).

In England appliances are exempted by publication on a list by the Secretary of State in accordance with changes made to section 20 and 21 of the *Clean Air Act 1993* by section 15 of the Deregulation Act 2015. In Scotland appliances are exempted by publication on a list by Scottish Ministers under section 50 of the Regulatory Reform (Scotland) Act 2014.

Similarly in Northern Ireland appliances are exempted by publication on a list by the Department of Agriculture, Environment and Rural Affairs under Section 16 of the Environmental Better Regulation Act (Northern Ireland) 2016. In Wales appliances are exempted by regulations made by Welsh Ministers.

Your local authority is responsible for implementing the Clean Air Act 1993 including designation and supervision of smoke control areas and you can contact them for details of Clean Air Act requirements.

Further information on the requirements of the Clean Air Act can be found here : <https://www.gov.uk/smoke-control-area-rules>

The following list of Woodford models :

- Woodford 5kW stove
- Woodford 7kw stove
- Woodford 5kW Wide stove

are currently exempt or have been recommended as suitable for use in smoke control areas, when burning wood logs and when fitted with a factory set mechanical stop, to prevent secondary air closure beyond the 27mm, ??mmTBC and ??mmTBC open position respectively.



## 9 Recommended fuels

### 9.1 Wood

As a natural and renewable fuel, wood is the first choice for burning, however burning wood requires a little effort and planning.

Any type of wood is suitable (though hardwood is preferable) provided it is well seasoned and has a moisture content below 20%. This usually implies that the timber has been suitably stored to allow moisture to evaporate for at least 9 months in the case of soft wood, and at least 24 months in the case of hard wood. We recommend that for general burning, wood should be split into logs of no more than 100mm (4 inches) diameter.

If, when burning wood, you see signs of sticky tar inside the appliance or chimney, your wood is 'green' or too wet and requires further seasoning. An electronic moisture meter can be obtained in order to determine the moisture content of your wood fuel. Wet wood must not be used as this will greatly contribute to the creation of tar and creosote which may, in extreme cases, run down the chimney in liquid form. This will seriously damage both the chimney and the appliance and increase the risk of a chimney fire.

### 9.2 Mineral Smokeless (Solid Fuel)

With the optional solid fuel kit, your Woodford stove has been approved to burn mineral smokeless fuels.

It is important to ensure that your fuel is intended for use in a stove or closed appliance. Modern stoves are designed for use with the cleaner burning and smokeless fuels.

Flue & Ducting Ltd, recommends the use of approved smokeless fuels which have been deemed suitable for use on closed appliances including multi fuel stoves or boilers.

Authorised fuels suitable for Smoke Control Areas, please see (<https://smokecontrol.defra.gov.uk/fuels>)

For additional advise on fuels, please refer to the Solid Fuel Association ([www.solidfuel.co.uk](http://www.solidfuel.co.uk))

**DO NOT BURN Bituminous house coal or petroleum coke** in this appliance.

PLEASE NOTE : All test data, outputs and efficiencies stated in this instruction manual were obtained by burning 'Maxibrite' mineral smokeless fuel.

**DO NOT BURN Any form of plastics** in this appliance.

# USER GUIDE

---

## 10 Before using your stove

### 10.1 Pointers Before Use

Woodford stoves are designed to be operated with the fire door(s) closed at all times, apart from refuelling (when alight) or cleaning (when cold).

Never leave the appliance unattended for an extended length of time with the door(s) open.

Prior to lighting the stove for the first time, please check with the installer that:

- Installation and all building work is complete. (Refer to the installation guide.)
- The chimney is sound, has been swept and is free from obstruction.
- Building Regulations and any local by-laws have been followed during installation.
- All firebox liner panels and throat plate are in place.
- The chimney draw has been checked and is within specification (between 0.1 mb to 0.2mb, or 10-20 pascals). This ensures your stove will operate predictably and efficiently.
- Carbon Monoxide detector is correctly installed in the same room as the appliance.
- Suitable provision for combustion and ventilation air, depending upon building regulations have been undertaken by the installation fitter.
- Consideration must be given for the need for extra ventilation if another heating source needing air is to be operated simultaneously. If an extraction fan is proposed to be fitted to a connecting area of the house, after the stove has been installed, professional advice should be sought from a qualified engineer.

Ensure that you have read and understood these instructions before lighting the fire.

Always wear suitable protective fire gloves when refuelling your stove, such as the hot glove supplied with your stove. Always keep the hot glove away from naked flames and sparks, when re-fuelling the appliance.

We recommend that you light a small fire for the first few days of use to cure the paint and allow the castings to relax.

You may hear your stove produce clicking or ticking noises whilst it heats up or cools down. This is completely normal and is produced by the expansion and contraction of the steel components in your stove when its temperature changes.

## 11 Air inlet controls

### 11.1 Air Inlet

Your stove requires air to function, this enters the appliance via the circular duct at the rear of the stove. During installation, this circular duct can also act as the connection point for the direct air feed / ducting, depending upon the installation requirements.

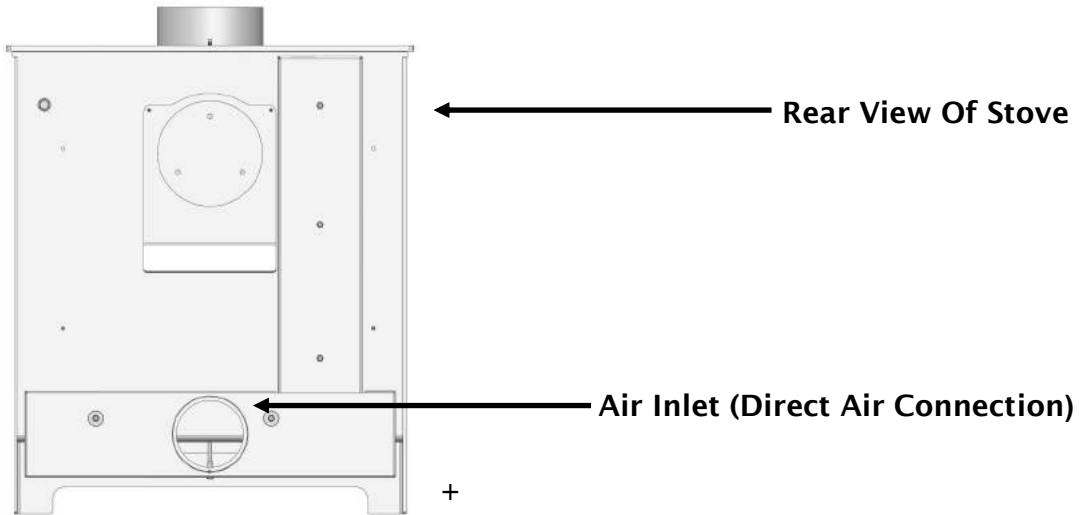

NOTE : DO NOT COVER OR PARTIALLY OBSTRUCT THE AIR INLET OPENINGS FOR THE APPLIANCE.

### 11.1.1 Primary air control location

The primary air control regulates the air entering the fire box chamber, supplying air below the grate. This control is situated below the fire door on the right hand side, when facing the front of the stove.

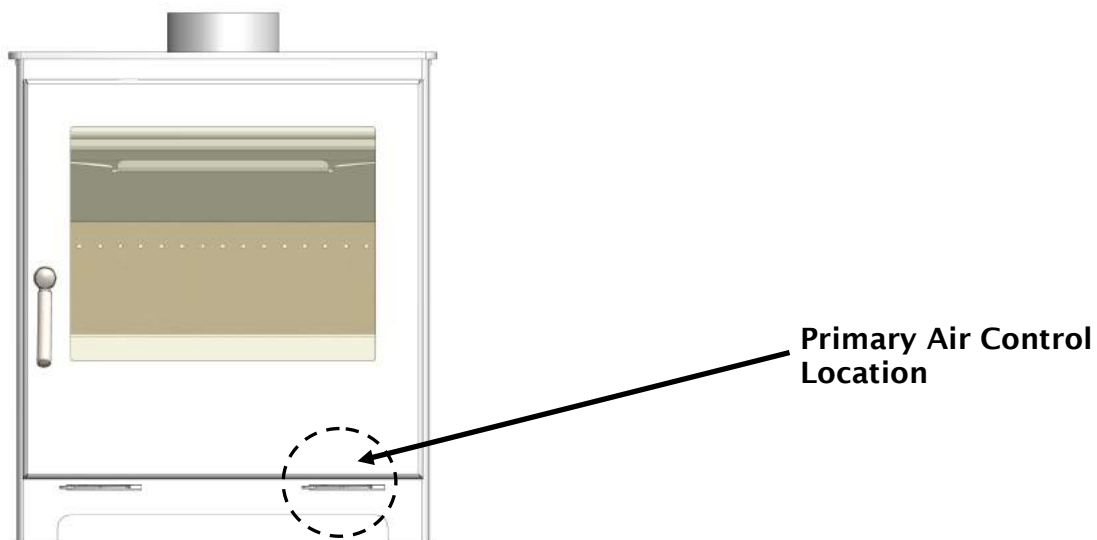

# USER GUIDE

## 11.1.2 Primary air control

The primary air control regulates the air entering the fire box chamber, supplying air to the under side of the fuel bed.

The control has an internal rotary plate with slots, housed inside the body of the appliance and is located below the right hand corner of the fire door assembly.

Sliding the control knob to the right, as far as it will go, achieves the fully open position, see figure 1. Sliding it to the left will shut down / reduce the air as shown in figure 2.

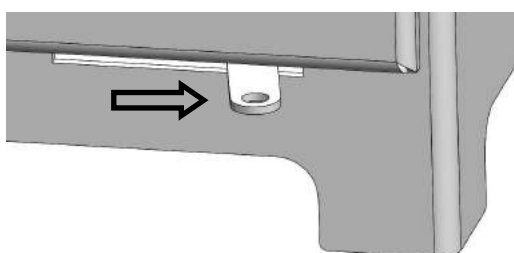

Fig. 1. Fully Open Position

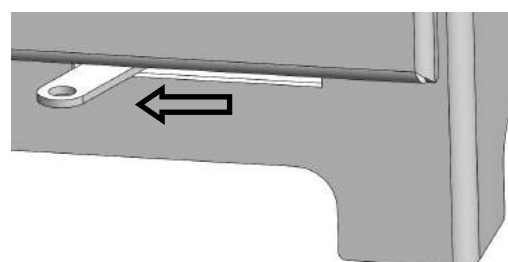

Fig. 2. Fully Closed Position

## 11.1.3 Secondary air control

The secondary air control regulates the air entering the fire box chamber, supplying an overdraught of air to the fuel bed, together with supplying air in front of the glass viewing panel within the door assembly. This is known also as the air wash system.

This control is situated below the fire door on the left hand side, when facing the front of the stove.

Secondary Air Control  
Location

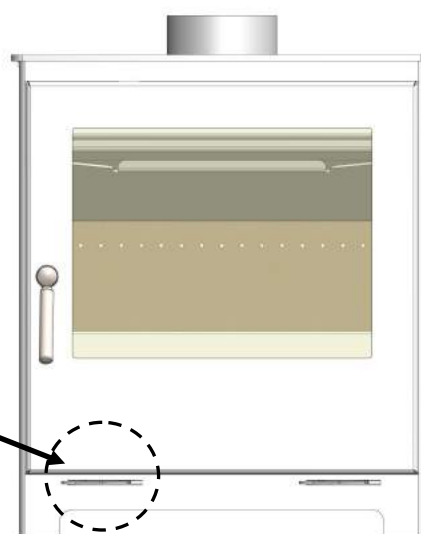

# USER GUIDE

The control has an internal rotary plate with slots, housed inside the body of the appliance and is located below the left hand corner of the fire door assembly, when looking at the front of the appliance.

Sliding the control knob to the right, as far as it will go, achieves the fully open position, see figure 3. Sliding it to the left will shut down / reduce the air as shown in figure 4.

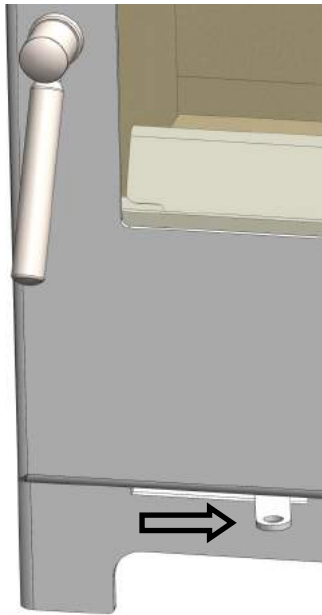

Fig. 3. Fully Open Position

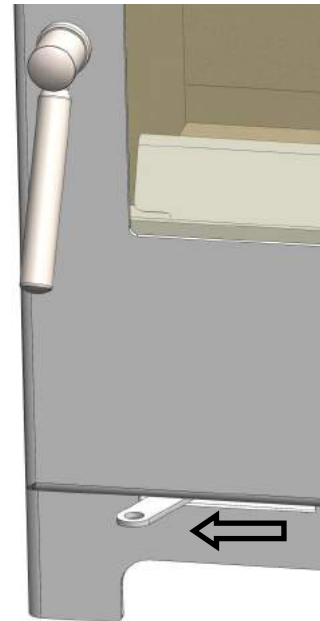

Fig. 4. Closed / Reduced Position



**NOTE :** If your stove installation is within a smoke control area, it will be fitted with a restrictor plate acting as a mechanical stop for the secondary air control. This will not fully close, thus allowing a bleed of air to the fire box to reduce smoke emissions.

## 11.1.4 Tertiary Air

All models have tertiary air supply that can be seen working during certain conditions during the burning period. The outlet for the tertiary air, is at the rear of the fire box chamber, just below the throat plate through a series of small holes within the rear liner brick (See page 6).

Tertiary air is employed, to provide additional air to the upper areas of the fire box to promote additional burning of the unburnt combustion gases and thus ensuring a cleaner burn emission.

There is no user adjustment required for the tertiary air, as the required air supply is factory set during the production process.

# USER GUIDE

---

## 12 Lighting your stove

### 12.1.1 Smoke control areas

Please check whether your dwelling is located in a smoke control area before installation or use. Please check with your local authority or <https://www.gov.uk/smoke-control-area-rules>.

### 12.1.2 Fuel overloading

The maximum amount of fuel specified in this manual should not be exceeded, overloading can cause excess smoke. Please see technical data section in this manual.

### 12.1.3 Operation with door left open

Operation with the door open can cause excess smoke. The appliance **MUST NOT** be operated with the appliance door left open except as directed in the instructions.

### 12.1.4 Dampers / Air controls left open

Operation with the air controls or appliance dampers open can cause excess smoke. The appliance must not be operated with the air controls, appliance damper or door(s) left open except as directed in these instructions.

## 12.2 Burning wood

When wood is burnt, it is in fact the volatile gases released from the wood, that burn and this requires a good supply of air coming from above the fuel. For this reason we will use all the air inlets while igniting the stove, but will then reduce this to air coming from the air wash system and over draught. As much as 40% of the heat from burning wood is obtained from secondary combustion and this can be severely hampered by air entering the fire box from below the fuel.

- 1) Set the fire, by placing several layers of dry kindling wood into a criss-cross grid pattern on top of the grate bars. The use of two or three fire lighters may assist in lighting the kindling.
- 2) Fully open the primary and secondary air controls and light the fire lighters and or kindling wood.
- 3) After the kindling has caught light, you should almost close the fire door leaving it ajar by about 10mm. This will aid flue draw during the initial lighting of the fire.
- 4) The flue temperature and draw should be established after five minutes and the kindling reduced to form an ember bed. Carefully load the stove with well seasoned wood and fully close the fire door.
- 5) After ten minutes, fully close the primary air control and regulate the secondary air control to control the burn rate and maintain clear glass, typically by reducing to approximately half open.

## 12.3 Burning solid fuels

Solid fuel burns best with its air supply for combustion coming from underneath the fuel. To achieve this, the burn will be controlled by the primary air control.

A reduced setting may also be required on the secondary air control, to maintain clear glass on the door assembly.

Riddling the stove occasionally will also help to ensure that burnt fuel does not prevent the supply of air from reaching the fuel bed.

The procedure for lighting / burning solid fuel, is as follows : -

- 1) Set the air wash (secondary) air control to about one quarter open and the primary air control fully open.
- 2) Lay the fire by using several layers of dry kindling wood into a criss-cross grid pattern on top of the grate bars. The use of two or three fire lighters may assist in lighting the kindling.
- 3) After the kindling has caught light, you should almost close the fire door leading it ajar by about 10mm. This will aid the flue draw during the initial lighting of the appliance.
- 4) Once the flue draw has been established, after about five minutes, carefully load the stove with solid fuel, it is suggested that the initial loading is best done using fire tongs and placing the fuel, rather than shovelling the fuel.
- 5) When the fire is well alight regulate the burning rate by controlling the primary air control.
- 6) The secondary air control (air wash) should be closed enough to enable a sufficient supply of air to the glass to keep the door glass clean.
- 7) Whilst burning solid fuel it can be beneficial to occasionally riddle the grate bars so any burnt fuel will fall between the grate bars into the ash pan. Please see 'Section 7—Further Information' on the procedure for riddling.

# USER GUIDE

## 12.4 Warning - Fume / Smoke emissions

Properly installed, with a suitable flue or chimney, operated and maintained correctly, this appliance will not emit fumes into the dwelling. Occasional fumes when de-ashing and refuelling may occur. However, persistent fume emission is potentially dangerous and must be investigated by an approved / registered installer.



**STOP USING THE APPLIANCE IF YOU SMELL FUMES OR SEE SMOKE ESCAPING.**

If fume emission does persist, the following immediate actions should be taken:

- Open doors and windows to ventilate room.
- Let the fire die or extinguish and safely dispose of fuel from the appliance.
- Check for flue or chimney blockage, and clean if required.

Seek expert advice from your approved installer.

Do not attempt to re-light the fire until the cause of the fume emission has been identified and corrected.

## 12.5 Refuelling on to a low fire bed

If there is insufficient burning material in the fire bed to light a new fuel charge, excessive smoke emission can occur. Refuelling must be carried out onto a sufficient quantity of glowing embers and ash that the new fuel charge will ignite in a reasonable period. If there are too few embers in the fire bed, add suitable kindling for ignition to prevent excessive smoke.

**Important notes on usage, to meet the requirements of Smoke Control exemption -**

- Always recharge onto hot embers.
- After re-charging, fully open both the primary and secondary air controls for the following times, in order to establish good combustion -

Woodford 5kW — 4 minutes with the fire door ajar

Woodford 7kW—x to x minutes (TBC)

Woodford 5kW Wide — x minutes together with fire door ajar (TBC)

- Do not leave the appliance unattended until flames are well established.
- Periodic burning out of the fuel bed at high output to combust any remaining charcoal.



# USER GUIDE

## 12.6 Smoke Control Area (The Clean Air Act 1993 & Smoke Control Areas)

If the stove is to be installed in a designated Smoke Control Area (further information can be found via <https://www.gov.uk/smoke-control-area-rules> ) then the installer will have fitted the a restrictor plate for the secondary air lever to prevent total closure of this air control.

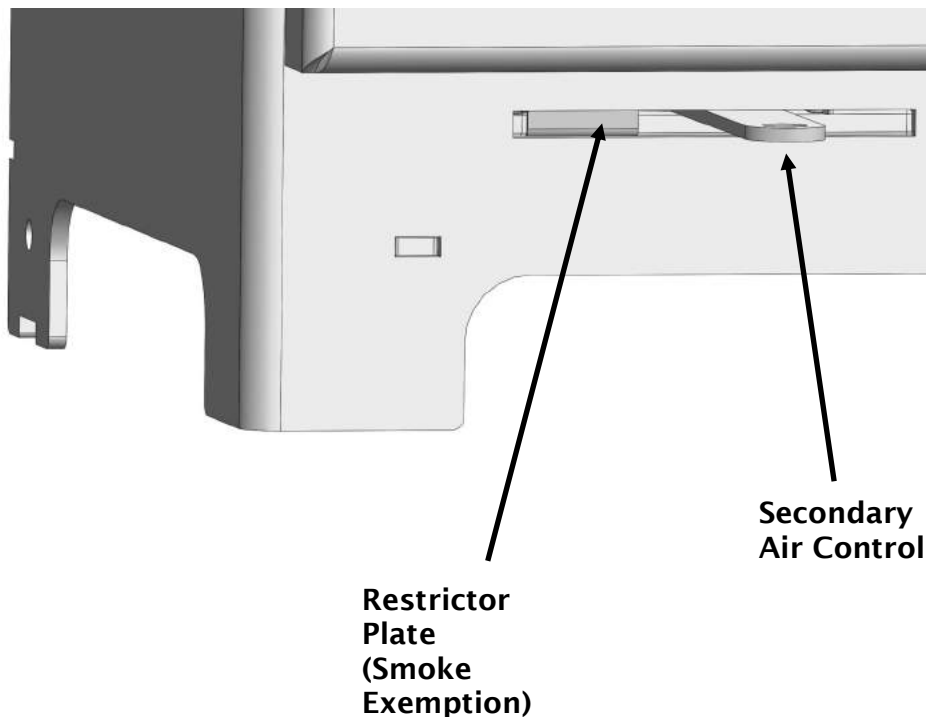

Fig. 5. Fitted Smoke Exemption Restrictor Plate



### NOTE :

The minimum air control setting is governed in manufacture to meet the requirements of Smoke Control exemption and as a result the appliance will **NOT** shut down completely when in the minimum air position setting.

Removal or modification of the fitted air control plate (See Fig. 5) is illegal when the appliance is installed in a smoke exemption area and doing so may result in prosecution and fine.

## 12.7 Typical burn for nominal output

To perform the most efficient burn at the nominal rated output please consult the specification table at the rear of this manual. Please note, many factors can effect the nominal output, so the stated weights of fuel (Seasoned hard wood, Beech and Mineral solid fuel, 'Maxibrite') are a guide, which is a representation to laboratory test burn conditions.

# USER GUIDE

---

## 13 Further information for all stove owners

### 13.1 Reduced burning (Slow Combustion)

When wood is burnt slowly in a closed appliance (eg: air controls at the minimum setting), it produces moisture and tar, which will create condensation and deposits in the chimney. This effect can be minimised by burning hard for a short period, fifteen to twenty minutes twice a day.

To avoid chimney problems your appliance should not be burnt at a reduced burn rate without a period of fast burning. Fast burning is when the stove is burnt with a 'lively flame' and a higher temperature. We strongly advise against stoking the fire with wood and reducing the air inlets before leaving the stove to extinguish (perhaps when retiring to bed) as this can lead to a cooling of the stove and flue also resulting in incomplete combustion, sooty deposits and high levels of pollutant gases released into the environment.

### 13.2 Over firing

**DO NOT** over fire your appliance. Firing the stove at maximum for prolonged periods may result in over-firing. If the chimney connector or casing glows red the appliance is being over-fired and this may result in a chimney fire. Other signs include warping and a red-oxide colouring will demonstrate the over- heating of internal parts; body paint which has turned dusty white is also indicative of such use.

### 13.3 Chimney fires

Used in the correct manner, with the correct fuel and regular maintenance a chimney fire should never occur, however in the even of a chimney fire, the following procedure should be actioned without delay:

- **Call the fire service—DIAL 999**
- **Immediately close all of the air inlet supplies on the appliance, to reduce the air supply to the stove.**
- **Move items of furniture and combustibles away from the surrounding area of the stove, to reduce the risk of fire and allow access for the fire service.**
- **Ensure access to the loft space is available.**
- **Evacuate the property.**

### 13.4 Periods of non-use (summer months)

Please ensure that your stove is left clean and moving components are well lubricated with a water repelling corrosion inhibitor for the summer months (during periods of prolonged non-use). If possible store the throat plate outside of the stove. Check all moveable components at regular intervals, to ensure they are moving freely. Allow air movement through the stove by opening the primary air inlet control(s) to about half way, open or leave the door ajar. This will allow a free flow of air through the appliance thus preventing moisture and condensation forming inside the stove and chimney. This preventative maintenance will ensure your stove stays in the best condition for the coming winter months.

# USER GUIDE

## 13.5 Riddling the firebox

To riddle the grate, the main fire door will need to be open, carefully open the fire door, using the stove glove supplied. Located the centrally mounted riddle lever, using the glove, move the lever left to right, repeatedly, until the ember / ash bed is has been reduced.

Note : if this procedure is performed vigorously then ash maybe discharged from the firebox, care should be taken to avoid this from happening.



Fig. 6. Riddle Lever

## 13.6 Ash removal

The ash pan should be emptied when the level of ash reaches the top of the ash pan. On no account should the ash be allowed to build up to touch the underside of the grate, as this will greatly reduce the life span of the grate.

**To remove the ash pan ALWAYS USE the supplied glove & operating tool -**

- Open the door of the stove, pausing briefly when ajar so as to allow the fire to adjust to the increased air supply.
- Insert the fork end of the operating tool into the ash pan (see Fig. 7.).
- Carefully withdraw the ash pan from the ash pit chamber.
- Empty the ash into a suitable metal container. Replace the ash pan into the stove, reversing the above procedure and close the fire door.

**WARNING :** Ash can be very hot!! Care must be taken not to burn hands or household objects with falling embers—ALWAYS USE THE GLOVE SUPPLIED.

Empty only into a metal container. Even if the ash appears cold, red hot embers maybe concealed and could easily start a fire or cause an injury.

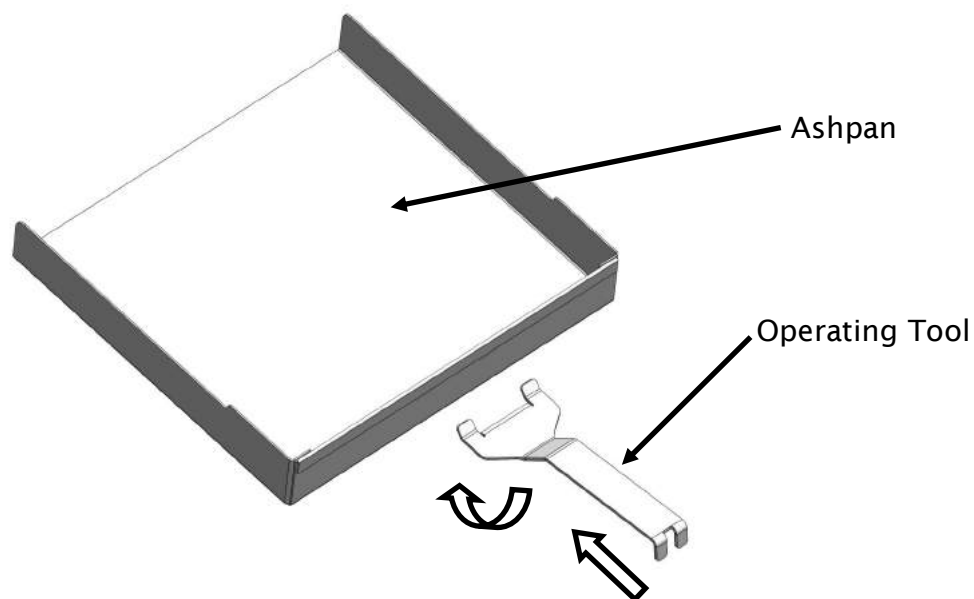

Fig. 7. Ash Pan

## 13.7 Replacement parts

Genuine replacement spare parts can be obtained from your Flue & Ducting retailer / dealer.

You can find a complete list of spares and consumables such as liners, replacement grate parts and throat plates as well as items to enhance its visual appearance and efficiency such as stove paint and rope kits.

It is worth noting that the fitting of non-official parts to your stove will invalidate its guarantee.

## 13.8 Classification

All Woodford stoves are classed as intermittent operation. There by meaning, to give nominal rated output, you will have to refuel a minimum of 45min for wood or 1hr for solid fuel, as stated in EN 13240:2011 +A2:2004.

## 13.9 Adverse weather conditions

If due to adverse weather conditions your stove does not operate correctly and causes the stove to emit smoke, do not treat it as a nuisance, this smoke will indicate that carbon monoxide is being emitted into the room. Extinguish the stove by reducing the firing rate, open windows and allow the stove's fuel to burn out before closing the windows. The probable cause is insufficient draw, check flue ways and have the chimney tested for flue pressure.

# USER GUIDE

## 13.10 Door glass

The door glass should remain clear during normal burning. However under certain conditions, such as burning at a low or slow rate, using damp wood or overnight burning, the glass may become somewhat blackened. To remedy this, operate the appliance at a fast rate. Alternatively when the stove is cold, open the door and clean the inside face of the glass with a damp cloth or with glass cleaner.

## 13.11 Fire door handle



Care must be taken when opening and closing the fire door as any surrounding surfaces will be VERY HOT.

**ALLWAYS USE THE HOT GLOVES WHEN USING THE FIRE DOOR / RIDDLE HANDLE—  
RISK OF PERSONAL INJURY MAY OCCUR.  
CAUTION MUST BE GIVEN WHEN RE-FUELLING THE APPLIANCE, KEEP THE  
GLOVE AWAY FROM NAKED FLAMES & SPARKS.**

# USER GUIDE

## 14 Care for your stove

The need for regular maintenance on your stove will ensure, safe and efficient use of your appliance. The following item listing should be checked and inspected by a competent person or engineer on a regular basis.



**PLEASE ENSURE THAT THE STOVE IS UNLIT AND COLD, BEFORE ATTEMPTING TO INSPECT THE BELOW ITEMS -**

### 14.1 Adjusting the door hinges

Once the appliance has been under fire for a period of time the fire door may appear to have moved out of alignment with relation to the door aperture or catch. This is quite normal and due to the settling of the casting. It may be possible to tighten the retaining screws on the hinge assembly.

**If the fire door needs to be raised, please follow the instructions below:**

Open the fire door so that it is at right angles to the front of the stove.

Apply a lifting pressure to remove the door from the hinge assemblies, it may be necessary to move the door assembly from left to right whilst applying an upward force, to release the door from the hinges.

Drop one washer (M5) over the top hinge pin. Align the door assembly onto the hinge and apply a downward pressure to re-fit the door onto the hinge assemblies. Check & repeat again if necessary.

### 14.2 Liners / firebricks

The stoves liners (also known as firebricks) may become cracked after long periods of heavy use or after being knocked by the loading of fuel or a poorly aimed fire poker. If the liners are still staying in situ and are able to support themselves correctly there is no need to replace them. Cracked liners will not in themselves effect the performance of the stove.

### 14.3 Throat plate

The throat plate can be removed from the stove, by lifting the throat plate up and removing the rear liner, this will then allow the rear of the throat plate to swing down. Disengage the front lip of the throat plate from the upper location bracket. Rotate the throat plate, diagonally across the firebox, manipulating the plate through the door opening.

Any accumulated deposits should be cleaned off, this is best done with a brush. Whilst doing so, inspect the throat plate for any damage.

Replacement throat plates can be sourced from your local dealer or via the internet at [www.flue-ducting.co.uk](http://www.flue-ducting.co.uk)

## 14.4 Fire door seal

The rope seal around the edges of the main fire door should also be checked. Look for signs of fraying, peeling away or the ends not meeting. If the rope is unable to create a good seal with the stove body it should be replaced. A poor seal will decrease your ability to control the burn rate and its efficiency whilst leading to an increase in heat lost through the flue.

## 14.5 Cracked glass

It is not recommended to operate the stove with cracked glass; this can lead to over firing due to air leaking into the firebox and it may fail completely leading to personal injury or a fire.

You should discontinue use of your stove until it has been repaired. You can source replacement glass kits from [www.flue-ducting.co.uk](http://www.flue-ducting.co.uk) or your local retailer.

## 14.6 Chimney / Flue Sweeping

Sweeping should be carried out with an appropriate sized bristle brush and rods to suit chimney size and type. As with all appliances regular sweeping of the flue / chimney is essential to avoid dangers of blockage and the escape of poisonous fumes. Access for cleaning should also be incorporated in the chimney (eg: soot door or access through the register plate etc).

It is important that the flue connections, flue pipe and chimney be cleaned prior to lighting after a prolonged period of non use.

## 15 Further resources / information

### 15.1 Information

- Competent Person Schemes  
<https://www.gov.uk/guidance/competent-person-scheme-current-schemes-and-how-schemes-are-authorised>
- Document J Building Regulations (Combustion Appliances)  
[www.planningportal.gov.uk/](http://www.planningportal.gov.uk/)
- The National Association of Chimney Sweeps (NACS)  
[www.nacs.org.uk/](http://www.nacs.org.uk/)
- Smoke Control Areas—The Rules  
[www.gov.uk/smoke-control-area-rules](http://www.gov.uk/smoke-control-area-rules)

### 15.2 Specification

All Woodford stoves are manufactured and independently tested to EN standard 13240 and are CE marked. Within the above EN standard, material specifications and criteria are defined.

# USER GUIDE

---

## 16 Guarantee

### 16.1 Guarantee

If any part of the main body of the stove fails due to a manufacturing or material defect during the guarantee period that applies in respect of the relevant stove (as set out below), Flue & Ducting Ltd will, at its sole discretion, repair or replace your stove, for no charge.

For the purposes of this guarantee, a material or manufacturing defect includes the splitting or cracking of the main body (defined as the steel outer casing and items fixed immovably to the casing).

Damage caused by over-firing or over-heating is not covered. Warping and a red-oxide colouring will demonstrate the over-heating of internal parts; body paint which has turned dusty white is also indicative of such use.

The following guarantee periods shall apply in respect of the following :

Woodford stoves come with a **LIFETIME** warranty to the main body of the stove.

The external paint finish carries a one-year guarantee only.

This guarantee is subject to the Terms and Conditions set out below.

### 16.2 Terms and Conditions

The following terms and conditions must be satisfied in order for your stove to be covered by the guarantee set out above:

1. Your stove must have been purchased from an officially approved dealer.
2. You must be the original purchaser of the stove in order to make a claim. This guarantee is not valid in relation to any claims made by someone who did not originally purchase the stove from Flue & Ducting Ltd or an approved retailer / dealer.
3. Any claim under this guarantee must be made through the approved dealer where the stove was purchased and accompanied by proof of purchase (e.g. a valid receipt). Stoves not purchased from an approved retailer / dealer will not be covered by this guarantee.
4. Your stove must be installed in the UK for this guarantee to be valid. Stoves installed outside of the UK will not be covered by this guarantee.
5. Your stove must have been installed by a suitably qualified person and in accordance with the manufacturer's installation instructions. Stoves not installed by a suitably qualified person or not installed in accordance with the manufacturer's installation instructions will not be covered by this guarantee.



# USER GUIDE

6. Any claims under this guarantee shall not be valid where the installation of the stove does not conform to all required building regulations and other legislation in force at the time of purchase and where flue draw readings have not been made to confirm a suitability of the flue. The manufacturer's decision as to whether this condition has been satisfied shall be final.

7. The guarantee does not cover damage caused to the stove through careless handling or misuse or neglect of the appliance (misuse and neglect being not following the manufacturer's instructions and user guides in relation to the stoves, including the use of non-recommended fuels).

8. The following consumable service items are not covered by this guarantee:

· Firebox linings · Grate · Fuel retainer · Throat plate · Door/Door glass · Seals

9. The guarantee does not cover damage caused by storing or using the stove in a damp environment, defects or faults caused by local conditions such as draught problems and chimney defects or corrosion caused by condensation, damp or water ingress into the flue, chimney or the surrounding of the stove.

10. The guarantee is only valid if the stove is serviced and checked annually by a suitably qualified heating engineer, with documentation to be retained and produced in the event of a claim being made.

11. The guarantee is only valid where any spare parts used are supplied by Flue & Ducting or an approved retailer / dealer. The use of spares other than those supplied by Flue & Ducting Limited shall invalidate the guarantee. Parts can be purchased through an approved dealer or directly from Flue & Ducting, online at [www.flue-ducting.co.uk](http://www.flue-ducting.co.uk)

12. The guarantee is not valid where any repairs or modifications have been made to the stove which have been carried out by anyone other than Flue & Ducting Ltd or its authorised representatives or approved dealers.

13. All guarantee periods commence on the date of purchase and are non-transferable and solely for the benefit of the original purchaser of the stove.

## 16.3 General

Our guarantee is offered as an addition to your statutory rights and will not effect your statutory rights. You can obtain information about your legal rights from trading standards office's or a citizens' advice bureau.

This guarantee is applicable in the UK only and operates exclusively in accordance with the laws of England and Wales.

If you believe your appliance is not working correctly or it has broken down, in the first instance please contact your local retailer or installer for assistance.

# TECHNICAL SPECIFICATION

TECHNICAL DATA	Woodford 5 kW	Woodford 7 kW	Woodford 5 kW Wide
Height (mm) (On Std Fitted Feet)	585mm	600mm	600mm
Width (mm) (Across Canopy)	457mm	522mm	522mm
Depth (mm) (Inc. Handle Boss)	385mm	385mm	385mm
Height To Centre Of Rear Flue (mm)	446.5mm	461.5mm	461.5mm
Depth From Back To Flue Centre (mm)	134mm	134mm	134mm
Flue Diameter –mm (Inch)	127 (5")	127 (5")	127 (5")
Minimum Distance To Combustible Materials & Maximum Hearth Temperature  Single Walled Flue, <u>Without</u> Rear Heat Shield Fitted	700 mm (Rear) 550 mm (Side) 51 °C (Hearth)	TBC (Rear) TBC (Side) TBC (Hearth)	TBC (Rear) TBC (Side) TBC (Hearth)
Minimum Distance To Combustible Materials & Maximum Hearth Temperature  Single Walled Flue, <u>With</u> Rear Heat Shield Fitted	350 mm (Rear) 525 mm (Side) 52 °C (Hearth)	TBC (Rear) TBC (Side) TBC (Hearth)	TBC (Rear) TBC (Side) TBC (Hearth)
Minimum Distance To Combustible Materials & Maximum Hearth Temperature  Duraflue Twin Walled Flue, <u>With</u> Rear Heat Shield Fitted	150 mm (Rear) 500 mm (Side) 44 °C (Hearth)	TBC (Rear) TBC (Side) TBC (Hearth)	TBC (Rear) TBC (Side) TBC (Hearth)
Weight Packed	75.4 Kg	TBC	TBC
Weight Nett	69.8 Kg	TBC	TBC

# TECHNICAL SPECIFICATION

TECHNICAL DATA	Woodford 5 kW	Woodford 7 kW	Woodford 5 kW Wide
Nominal Heat Output—Wood (Kw)	4.9	TBC	TBC
Efficiency Nett (%)	79.8	TBC	TBC
Mean Flue Gas Temperature (°C)	255	TBC	TBC
Mean CO Emission @ 13% O2 (%)	0.11	TBC	TBC
Flue Mass Gas Flow (g/s)	4.7	TBC	TBC
Typical Fuel Load To Achieve Nominal Rated Output Per Hour (Kwh/Kg) (Seasoned Hardwood)	1.17	TBC	TBC
Mean CH Emission @ 13% O2 (%)	86	TBC	TBC
Mean NOx Emission @ 13% O2 (%)	95	TBC	TBC
DIN Plus Particulates @ 13% O2 (%)	27	TBC	TBC
Ideal Log Length & Diameter (mm)	300 / 100	375 / 125	375 / 125
Nominal Heat Output—Solid fuel (Kw)	4.9	TBC	TBC
Efficiency Nett (%)	82.8	TBC	TBC
Mean Flue Gas Temperature (°C)	254	TBC	TBC
Mean CO Emission @ 13 % O2 (%)	0.10	TBC	TBC
Flue Mass Gas Flow (g/s)	3.6	TBC	TBC
Typical Fuel Load To Achieve Nominal Rated Output Per Hour (Kwh/Kg) (MSF Maxibrite)	0.69	TBC	TBC
Mean CH Emission @ 13% O2 (%)	26	TBC	TBC
Mean NOx Emission @ 13% O2 (%)	94	TBC	TBC
DIN Plus Particulates @ 13% O2 (%)	10	TBC	TBC

# flue&ducting

---

## Total Chimney Solutions

---



**All Woodford Stoves are manufactured in the UK**

---

### **Flue & Ducting Ltd**

Unit B, Herrod Avenue,  
Off Haigh Avenue, Whitehill Industrial Estate,  
Stockport,  
SK4 1NU  
United Kingdom

[www.woodfordcollection.co.uk](http://www.woodfordcollection.co.uk)

T: +44 (0)161 480 2994

Email : [sales@flue-ducting.co.uk](mailto:sales@flue-ducting.co.uk)