



Contact Details

Please note that some of the contact details on this PDF document may not be current.

Please use the following details if you need to contact us:

Telephone: 0844 879 3588

Email: customer.services@gdcgroup.co.uk

The Help Centre section of this website also features a wide range of information which may be of use to you and is available 24 hours a day. It includes:

- Manuals and guides downloads
- Servicing
- Where to buy our products
- Literature downloads

www.robinsontonwilley.co.uk/help

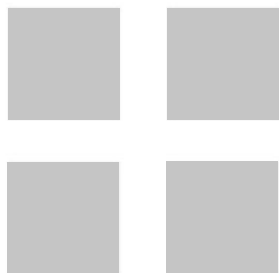

THE HOTTEST NAME IN HEATING

FIRECHARM LF ELECTRONIC

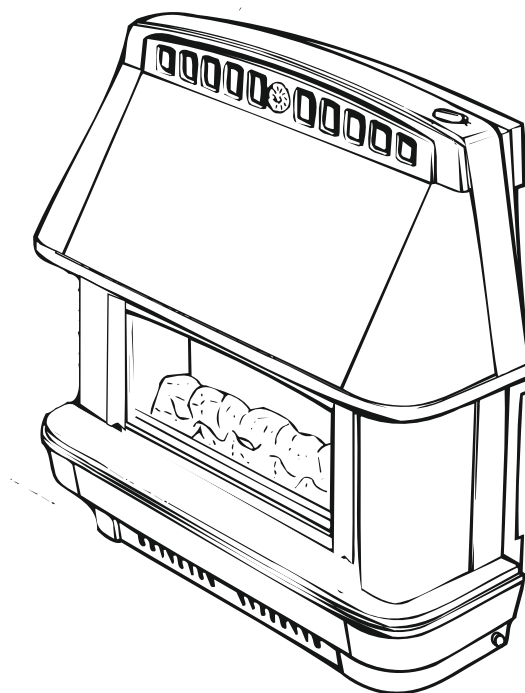

RADIANT/CONVECTOR GAS FIRE

BRONZE (G.C. No. 32 689 32)

BLACK (G.C. No. 32 689 33)

Installation and Servicing Instructions

**THIS APPLIANCE IS FOR USE WITH NATURAL GAS ONLY
IT MUST NOT BE USED WITH ANY OTHER TYPE OF GAS
THIS APPLIANCE MUST BE INSTALLED IN ACCORDANCE WITH THE RULES IN FORCE**

(Cat I_{2H} G20 at 20mbar Supply Pressure)

For GB & IE only

INSTALLER - PLEASE LEAVE THESE INSTRUCTIONS WITH THE USER

Robinson Willey
Firecharm and Sahara Live Fuel Effect Gas Fires

The efficiency of this appliance has been measured as specified in BS 7977-1:2002 and the result is 79.4%. The gross calorific value of the fuel has been used for this efficiency calculation. The test data from which it has been calculated has been certified by Notified Body No.0087. The efficiency value may be used in the UK Government's Standard Assessment Procedure (SAP) for energy rating of dwellings.

The above exceeds the minimum requirement of 63%.

INTRODUCTION

The FIRECHARM is a glass fronted radiant/convector fire with live coal effect. The outer case is finished in either black or bronze. The control and burner systems are designed to give varying decorative flames at different settings. Ignition is by battery spark generator operated by turning and pressing the control knob. The fire is fitted with combined flame supervision and oxygen depletion monitoring device. The fire may be hearth or wall mounted and is suitable for installation to brick chimneys, pre-cast flues or proprietary metal flues/flue boxes conforming to BS 715. The fire is for use on Natural Gas only.

GAS SAFETY (INSTALLATION AND USE) REGULATIONS.

It is the law that all gas appliances are installed by competent persons, i.e. Gas Safe registered Engineer, in accordance with these installation instructions, all the relevant parts of the local and national Building Regulations and all recommendations of the following British Standard Codes of Practice:

1. BS 5871 : Part 1
2. BS 5440 : Part 1 (Flues)
3. BS 5440 : Part 2 (Air Supply)
4. BS 715 & BS EN 1856
5. BS 6891
6. BS EN 1858 (and older pre-cast flues to BS : 1289 : 1975, BS 1289 : Part 1 : 1986 and BS 1289 : Part 2 : 1989)
7. The Building Regulations issued by the Department of Environment and the Building Standards (Scotland) (Consolidation) Regulations issued by the Scottish Development Department.
8. Any other relevant British Standard Code of Practice and/or Local Building Regulations, or in accordance with the rules in force.

NOTE: Purpose built ventilation is not normally necessary in G.B.. It is required in I.E., where the installation must be in accordance with IS 813.

This product uses fuel effect pieces containing Refractory Ceramic Fibre (RCF), which are man-made vitreous silicate fibres. Excessive exposure to these materials may cause temporary irritation to eyes, skin and respiratory tract, consequently, it makes sense to take care when handling these articles to ensure that the release of dust is kept to a minimum.

To ensure that the release of fibres from these RCF articles is kept to a minimum, during installation and servicing we recommend cleaning should be carried out in a well-ventilated area or in the open air, by gently brushing with the pieces held away from your face so that you avoid inhaling the dust. We do not recommend the use of a normal domestic vacuum cleaner, which may blow dust back into the air. *If a vacuum cleaner is recommended for use by your organisation, you must use a HEPA filtered vacuum to remove any dust and soot accumulated in and around the fire before and after working on the fire.* When replacing these articles we recommend that the replaced items are not broken up, but are sealed within heavy duty polythene bags, clearly labeled as RCF waste. This is not classified as "hazardous waste" and may be disposed of at a tipping site licensed for the disposal of industrial waste. Protective clothing is not required when handling the articles, but we recommend you follow the normal hygiene rules of not smoking, eating or drinking in the work area and always wash your hands before eating or drinking.

SPECIFICATIONS

1.0 TECHNICAL DATA

1.1 OVERALL DIMENSIONS (mm)

Height	635
Width	650
Depth	241
Height to top of flue spigot	495

1.2 HEAT INPUT/OUTPUT (GROSS)

Maximum input	5.57kW	19000 Btu/h
Maximum output	4.4kW	15012 Btu/h
Minimum input	1.55kW	5289 Btu/h
Minimum output	0.83kW	2822 Btu/h
Setting Pressure (Full on)		
Cold	17.0 mbar \pm 1	6.8in w.g. \pm 0.4
Supply Pressure	20 mbar	8in w.g.

1.3 BURNER - Aerated Duplex Burner

Aeration Adjustment - None

Injector (2 off) - Cat 77/200

Ignition - Battery Spark Generator

Control Tap - RW SP822240

1.4 SETTING - OFF, 7, 1, 2, 3, AND 4.

1.5 WEIGHT (Packed) - 23.5kg 51.7lb

Fig. 1A

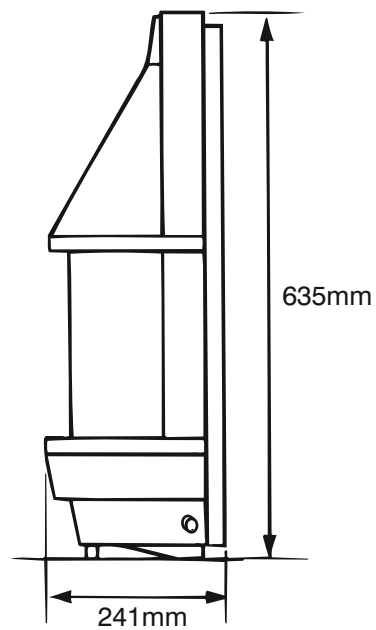
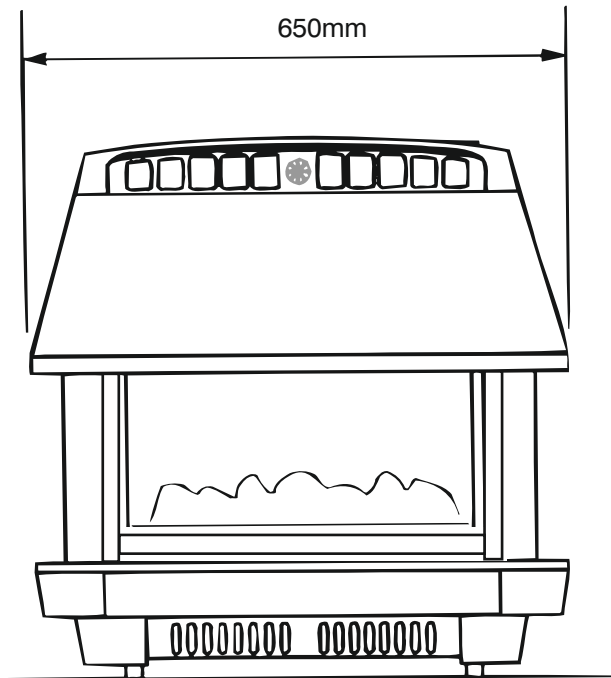

Fig. 1B

SITE REQUIREMENTS

2.0 SITE REQUIREMENTS

2.1 THE FIREPLACE AND SURROUND

The fireplace must be of non-combustible material having an opening size to the dimensions shown in Fig. 3A for Hearth Mounting and Fig 3B for Wall Mounting respectively. It is IMPORTANT that there is no combustible material or cladding in the vertical flat area shown in dotted lines in Figs. 3A and 3B. The fire should be installed so that no part of the combustible side wall is less than 508mm (20in) from the radiant source. If this is not possible, the combustible side wall must be suitably protected.

Some curvature of the surround is permissible but should this mean that there would be a gap between the back of the fire and the surround exceeding 13mm (1/2in) then a flue spigot extension (not supplied) must be used. The maximum projection of the spigot extension measured from the back of the fire is 150mm (6in).

The fire is suitable for use with lightweight surrounds whose continuous working temperature is not less than 100°C. A wooden shelf may be fitted above the fire. The underside of any combustible shelf of 150mm (6in) depth must be be at least 150mm (6in) above the top of the fire. For shelves of greater depth allow an increase of 13mm (1/2in) in shelf height for every 25mm (1in) in shelf depth. A minimum clearance of 75mm (3in) measured from the case side is required at each side for access/servicing, e.g. changing the battery.

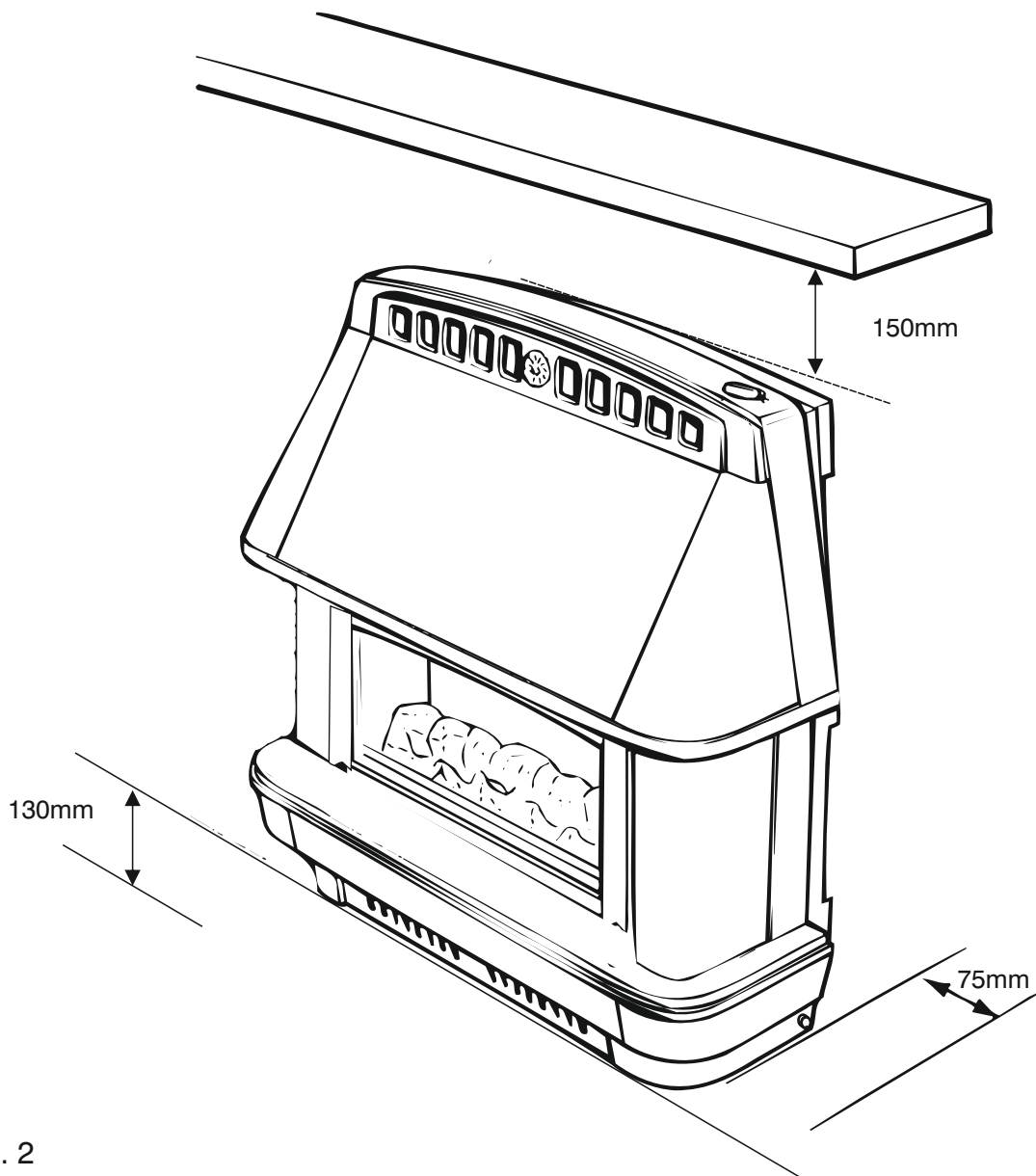
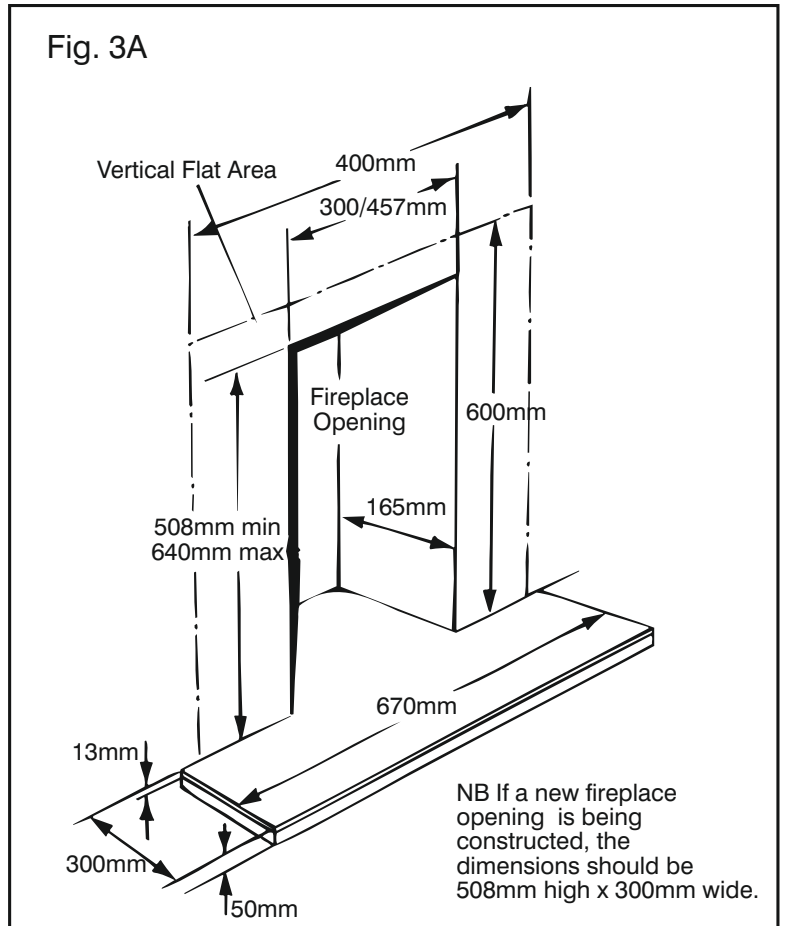

Fig. 2

SITE REQUIREMENTS

(a) HEARTH MOUNTING (Fig. 3A)

The hearth must be non-combustible material at least 13mm (1/2in) thick and measuring at least 670mm (263/8in) wide by 300mm (12in) deep with the fireplace opening central. Its top surface should preferably be 50mm (2in) above the floor level to discourage placing of rugs or carpets over it. Combustible cladding must be removed to a height of 600mm (235/8in) and a width of 400mm (153/4in).



(b) WALL MOUNTING (Fig. 3B)

The fire may be fitted onto a suitable non-combustible wall so that the top of the spigot opening in the closure plate is at least 595mm above the finished floor level.

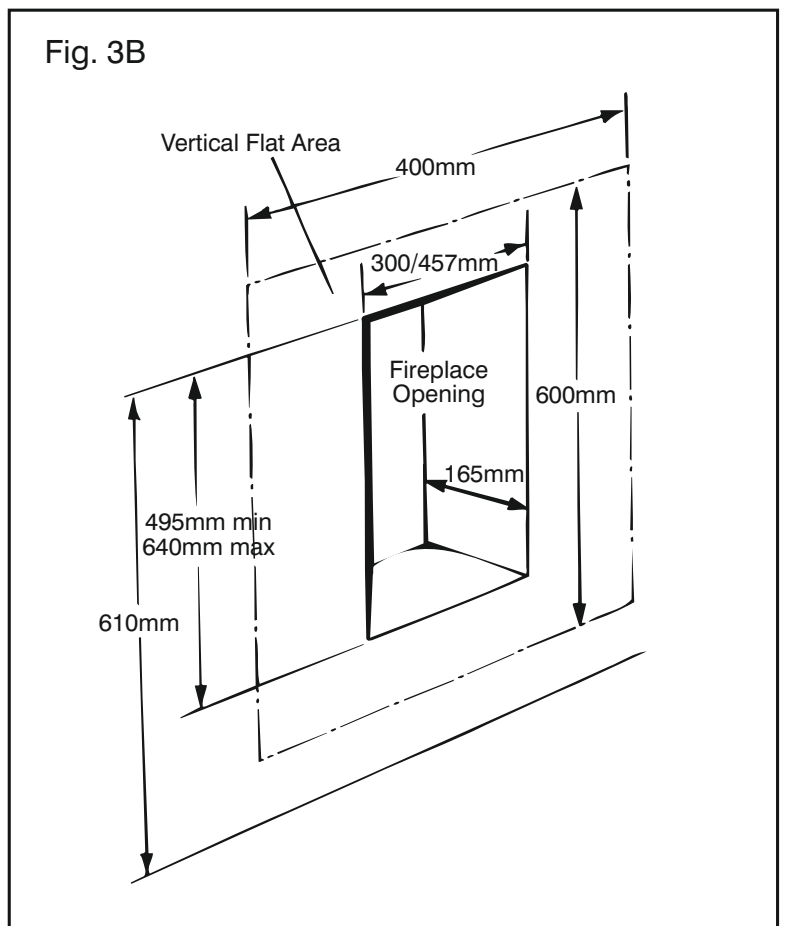

SITE REQUIREMENTS

2.2 BRICK CHIMNEY 228mm x 228mm (9in x 9in)

A chimney previously used to burn solid fuel must be swept prior to installation.

The chimney must be inspected to ensure that:-

- (a) It serves only one fireplace.
- (b) It is properly sealed so that combustion products do not escape from the flueways into the room.
- (c) It is not blocked by paper, rubble etc.
- (d) Any restriction such as a damper, register plate etc. must be removed or secured in the fully open position.
- (e) Any underdraught ventilation or additional air supply entering the fireplace or on the hearth must be sealed off.
- (f) The cross section area of the flue must not be less than 120cm² (19in²).
- (g) It must have a positive updraught.
- (h) It must have at least a 3 metre effective flue height.

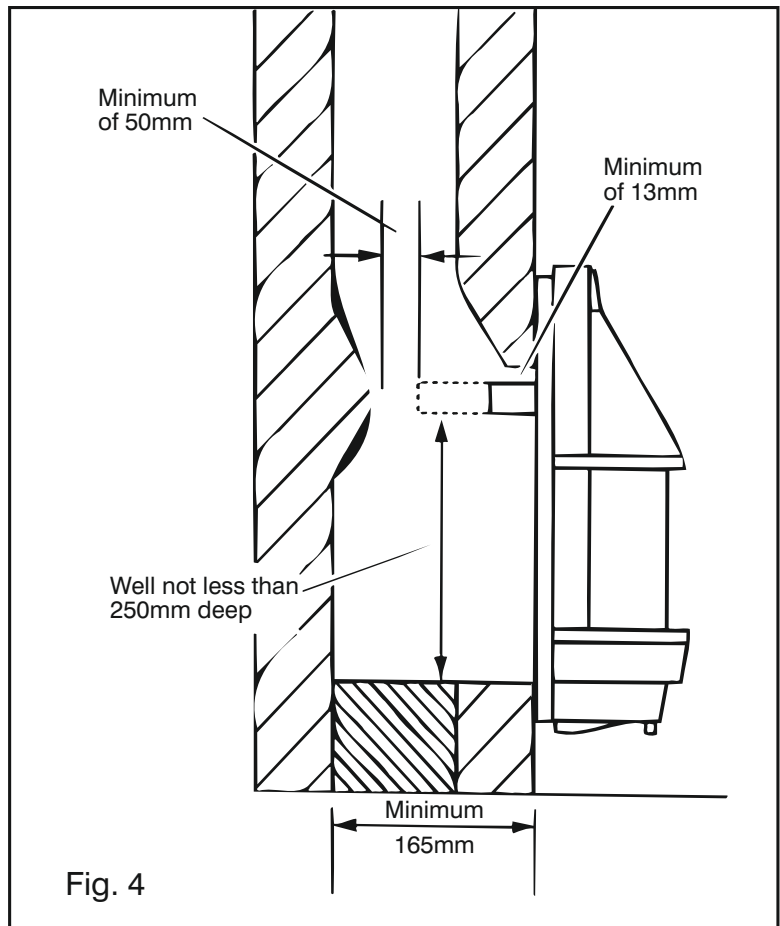

Fig. 4

2.2.1 Fireplace Dimensions (Fig. 4)

The dimensions of the catchment space behind the closure plate must meet the following requirements:-

- (a) The flue spigot/spigot extension must pass through the closure plate by at least 25mm (1in) and have a minimum clearance of 50mm (2in) between its open end and the nearest obstruction.
- (b) The catchment space below the flue spigot must be at least 250mm (10in) deep measured from the bottom of the flue spigot to the top of the catchment space or any "bricking up" at the bottom of the fireplace opening.
- (c) There must be a minimum clearance of 165mm (6 1/2in) between the back of the closure plate and the fireplace back brick.
- (d) The top of the spigot must be at least 13mm (1/2in) below the top edge of the fireplace opening. (See Fig. 4).
- (e) Ensure that the base of the fireplace is level with or lower than the hearth.

SITE REQUIREMENTS

2.3 PRE-CAST FLUE OF MINIMUM CROSS SECTION 198mm x 67mm (7³/₄in x 2⁵/₈in) (Fig. 5)

The fire is suitable for installation into a properly constructed pre-cast flue conforming to the standards listed on page 2, item 6, of at least 3m (10ft) effective height and having flueways of at least 198mm x 67mm (7³/₄in x 2⁵/₈in) or equivalent cross sectional area with no dimension less than 63mm (2¹/₂in)

The fireplace opening width must be between a maximum of 457mm and a minimum of 300mm. The opening height must be between a maximum of 650mm and a minimum of 508mm and a depth of at least 100mm.

Ensure that any mortar fangs between the blocks do not protrude into the flueways and, if raking blocks are used, they are fitted according to the manufacturers instructions and mortar is not allowed to drop down and accumulate in the raked positions.

Fig. 5

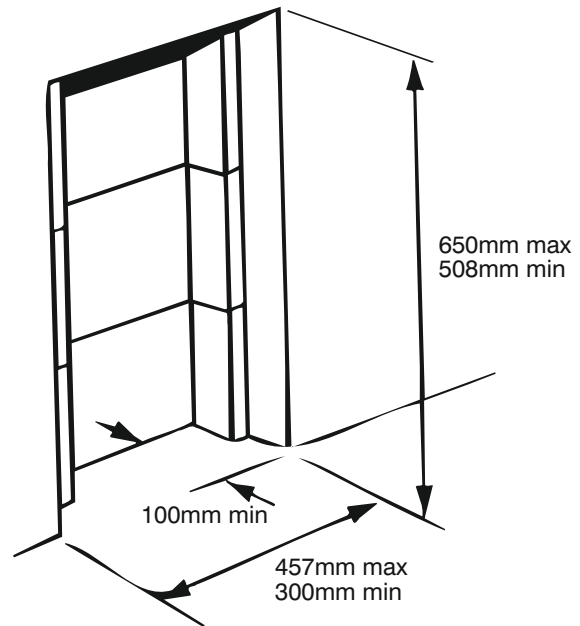

2.4 TWIN WALLED FLUES (Fig. 6)

This fire may be installed in a double walled or insulated metal box with a twin walled or insulated flue built to the requirements of BS 715 and BS EN 1856 respectively, at least 125mm (5in) in diameter and a minimum effective height of 3 metres (10ft). The depth of the opening must be at least 165mm.

Fig. 6

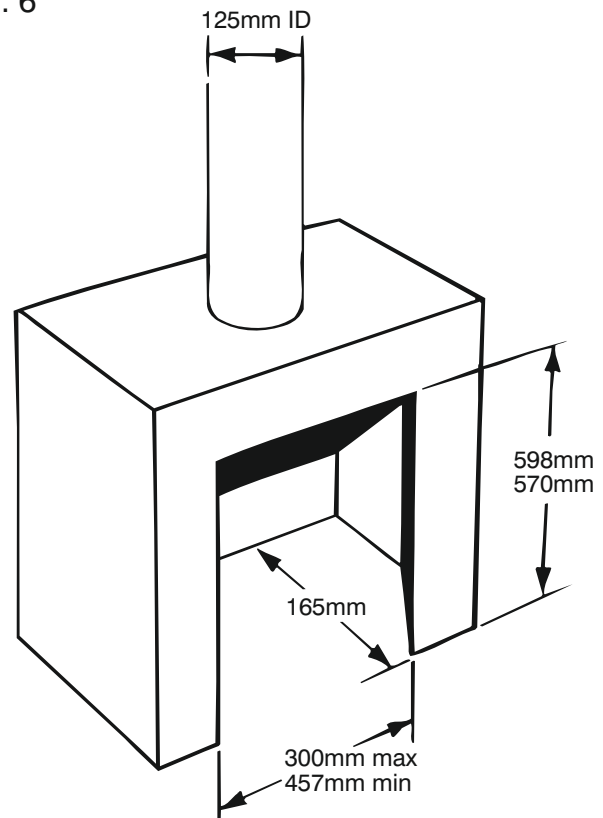

INSTALLATION

3.0 INSTALLATION

3.1 UNPACK THE FIRE AND ACCESSORIES

1. Remove the top fitment.
2. Lift the carton clear of the fire pack.
3. The fire is packed fully assembled except for:-
 - (i) Closure plate - in the rear cardboard fitment.
 - (ii) The accessory pack, in the LH base fitment contains:-
 - Spigot
 - Spigot Restrictor
 - Control knob adaptor
 - (iii) Coal Bed - in cardboard fitment inside fire.

Check these items and keep in a safe place.

3.2 FIT THE CLOSURE PLATE (Fig. 7)

IMPORTANT NOTES

- (a) It is recommended that in the event of the proprietary closure plate not being available on site, one should be obtained from British Gas or your local Supplier.
- (b) The top of the closure plate may be trimmed to prevent sealing tape being seen above the fire. Ensure that there is at least 10mm overlap on the fireplace opening. When wall mounting, it may be necessary to trim the bottom of the closure plate to prevent it showing below the fire.

After trimming a new air relief opening 100mm wide x 37mm high must be cut in such a position that it is unobstructed by any brickwork.

- (c) If a hole is cut in the closure plate for access to gas supply pipe, seal the opening between the gas pipe and the closure plate.

A	-	660mm
B	-	460mm
C	-	498mm
D	-	40mm
E	-	240mm
F	-	100mm
G	-	37mm

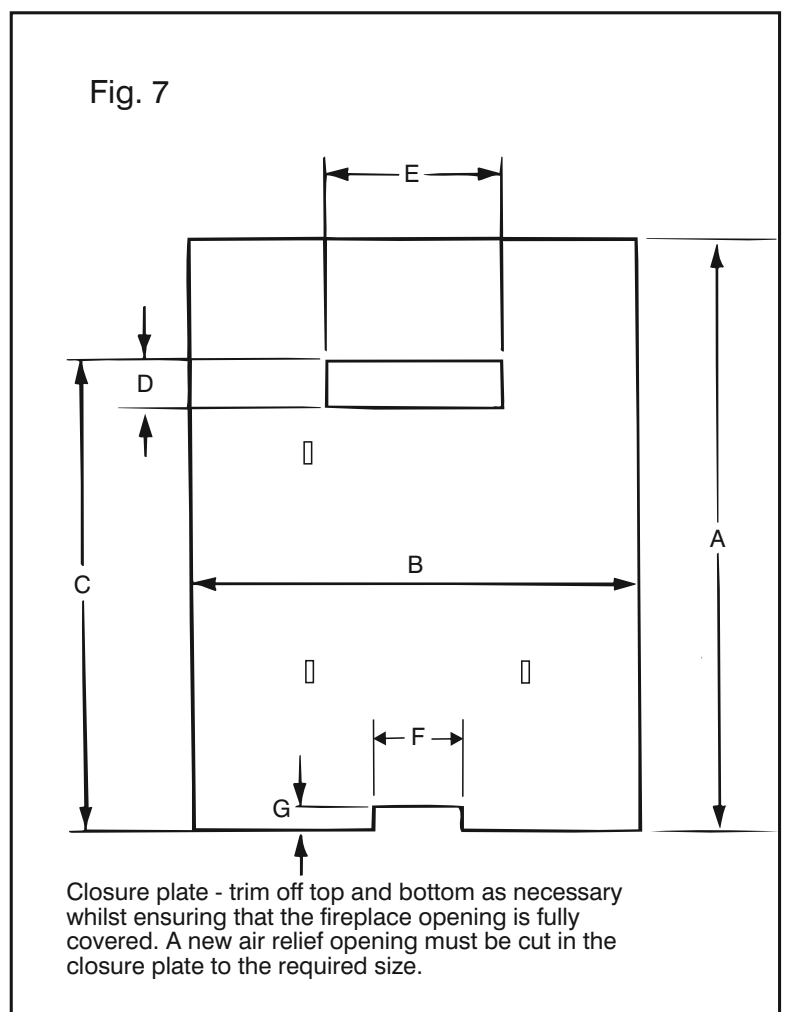

INSTALLATION

3.2.1 When Hearth Mounting

Fit the closure plate centrally across the fireplace opening and seal all four edges

3.2.2 When Wall Mounting

Ensure that the top of the spigot opening is at least 595mm above the finished floor level and at least 13mm below the top edge of the fireplace opening and that the air relief opening is unobstructed. Fit and seal the closure plate as described in Section 3.2.1.

3.3 CHECK THE FLUE PULL

Apply a lighted match, lighted paper or smoke match to the spigot opening in the closure plate. Observe if there is any up or down draught and if there is a definite flow into the spigot opening in the closure plate, proceed with fitting the fire. Any tendency to downdraught must be corrected. If no flow is indicated, heat the chimney with, for example, a roll of burning paper or a blow lamp for two or three minutes. If there is still no definite flow into the spigot opening, the chimney may require attention:

DO NOT FIT THE FIRE - SEEK EXPERT ADVICE

3.4 PREPARATION OF FIRE

3.4.1 Remove Outer Case

Stand the fire upright. Pull off the control knob. The outer case is held to the backplate by four screws, two on each side. Undo the four screws. Lift the outer case to clear the knob spindle, ease it out and put in a safe place.

3.5 FIT FLUE SPIGOT (Fig. 8)

(and Flue Spigot Restrictor if required)

The flue spigot consists of two identical pieces and is held to the back of the fire by six screws. The six screws, are already fitted around the flue outlet. Remove the top three screws but only loosen the bottom screws. Loosely secure the upper part of the flue spigot with the top three screws. Remove the bottom three screws and fix the other part of the flue spigot, sliding the side flange up the side of the upper part of the flue spigot. Tighten all six screws, the spigot restrictor is fitted using the two screws located immediately below the spigot, so that it restricts the lower part of the spigot.

If required a flue spigot extension is permissible up to a maximum projection of 150mm (6in) from the back of the fire. The spigot restrictor is NOT to be fitted if an extension is used.

Fig. 8

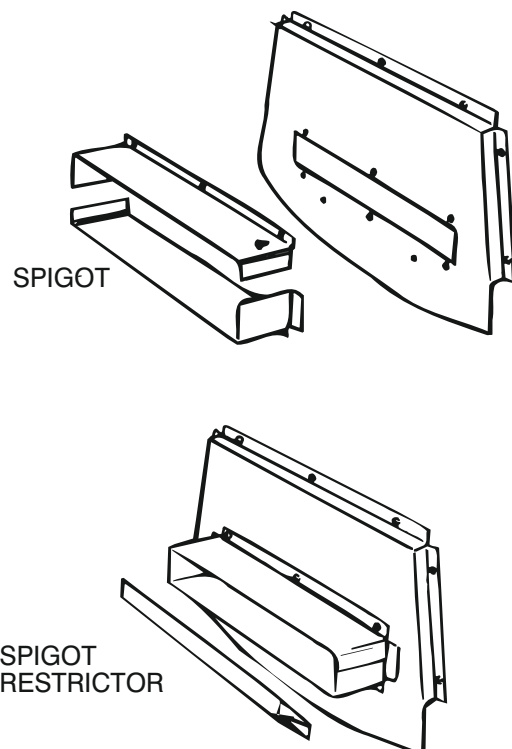

INSTALLATION

3.6 FLUE SPIGOT RESTRICTOR (Fig. 8)

- (a) Standard 228mm x 228mm (9in x 9in) brick chimney. The flue spigot restrictor must not be used if the chimney height is less than 4.3m (14ft) or if poor draught is suspected. If over 4.3m (14ft) in height with good draught, the flue spigot restrictor (Fig. 8) must be fitted.
- (b) Pre-Cast Flues.
The flue spigot restrictor must not be used.
- (c) 175mm (7in) and 125mm (5in) diameter lined flues. The requirements in (a) apply.

3.7 FIT GAS FIRE

3.7.1 Hearth Mounting

Place the fire in position against the wall. Levelling screws are fitted on the front legs and can be adjusted to take up any irregularities in the hearth. They should be locked after adjustment using the lock nuts provided. If the fire is fitted in a well type hearth, ensure that any kerb on the hearth does not obstruct the air inlet to the appliance.

3.7.2 Wall Mounting (to a non-combustible wall)

Undo the locknut on each of the levelling screws fitted to the legs and adjust the screws upwards as far as possible. It is essential that the minimum clearance from the floor level as indicated in Fig. 9 is observed. Keyhole slots and securing holes are provided in the backplate of the fire. These holes are suitable for size 10 rawplug fixing, using 50mm (2in) No. 10 round head screws (not supplied). Drill and plug the wall at four fixing point positions (Fig. 9). Partially insert the top two screws and mount the fire to the wall via the keyhole slots. Secure the fire by fitting the lower two screws and fully tightening the four screws.

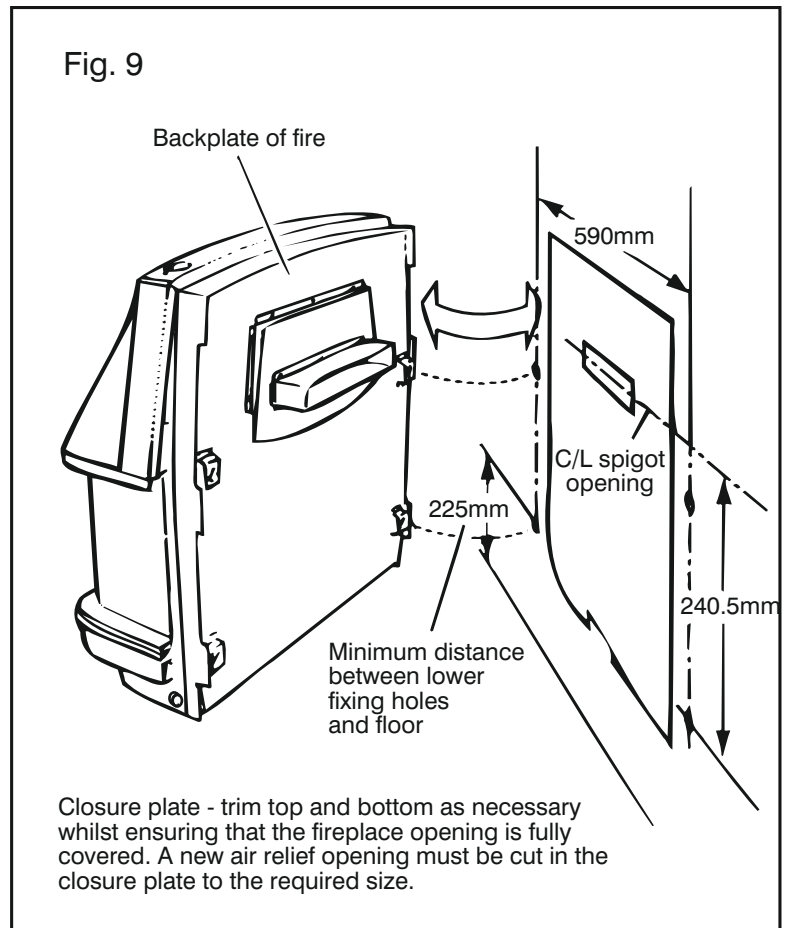

4.0 CONNECT TO GAS SUPPLY

- NOTE:
- (i) The appliance must be connected to gas with rigid or semi rigid tubing.
 - (ii) The fire is fitted with an 'isolating inlet elbow' for servicing.
 - (iii) Remove tray for access.

4.1 MAKE GAS CONNECTION

The gas inlet is suitable for right hand, left hand or concealed connection. Connect the fire to the gas supply via the union elbow provided. This union elbow should be fitted to the end of the supply pipe then held in position under the flare nut whilst this is engaged. Reach beneath the burner to perform this operation. Tighten the flare nut with a spanner. The inlet elbow has a nut and olive supplied, suitable for 8mm supply pipe.

4.2 TEST FOR GAS SOUNDNESS

(Refer to B.S. 6891)

The gas installation, including the meter, should be inspected and tested for soundness and purged.

4.3 TEST FOR CORRECT SETTING PRESSURE

Temporarily fit the control knob.

Remove the pressure test point sealing screw located in the control tap and attach a pressure gauge to the test point. Light the fire and leave on at full rate (Refer to Users Instructions). Check that the burner pressure is 17.0 mbar (6.8in w.g.) \pm 1.0 mbar (0.4in w.g.). If it is not, take the pressure at the meter to determine if there is a restriction in the installation pipework, or whether other appliances served by the same meter are starving the gas fire. Check that the flames on the outer section of the burner are blue, and those of the inner section slightly yellow tipping - as a result of the air shutter fitted over the top half of the burner aeration port.

Turn off the gas, remove the pressure gauge and replace the pressure test point sealing screw. Test for gas soundness around the sealing screw.

INSTALLATION

5.0 FIT REMAINING COMPONENTS

5.1 REFIT THE BURNER TRAY

5.2 FIT THE COAL BED

Fit the coal bed into the firebox as shown in Fig. 11 ensuring it is located behind the metal front rail.

5.3 FIT THE GLASS DOOR

Do this by inserting the top into the top clip of the firebox and guiding the lower holes over the firebox studs. Retain the glass door using the domed nuts provided.

5.4 REFIT THE OUTER CASE

This is done by placing it over the fire and refitting the 4 screws. Replace the control knob.

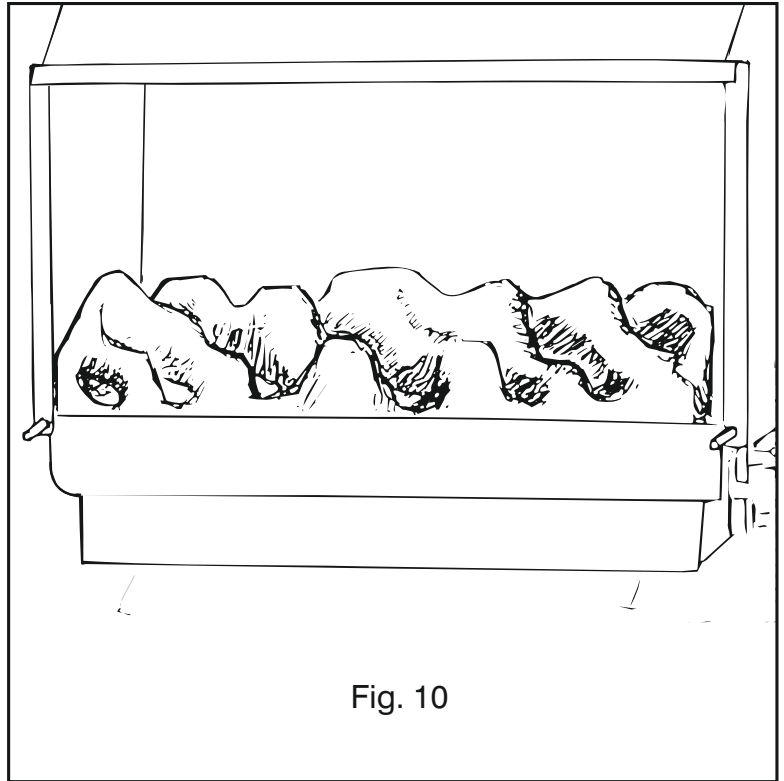

6.0 TEST FOR SPILLAGE

A spillage test must be made before the installed fire is left with the user. Proceed as follows: after removal of glass door mask (refer to Users Instructions). Light the fire and leave on at full rate. Close all doors and windows in the room and after the fire has been alight for 5 minutes insert a lighted smoke match held in a tube under the glass (Fig. 11) from the right or left side. The tube is positioned against the side panel and the smoke match must be in the gap at the bottom of the glass and 25mm from the right (or left) side of the door. If the smoke is drawn into the fire the installation is satisfactory. note: the smoke will be drawn in 'lazily', as the fire is fitted with a 'flue break' on the back. If the smoke is not drawn into the fire leave it running for 10 more minutes and repeat the test. If the smoke is still not drawn in check the sealing of the closure plate and if this is satisfactory remove the spigot restrictor. If the spigot restrictor has been removed re-fit the fire and check again for spillage. If spillage persists DO NOT LEAVE THE FIRE - SEEK EXPERT ADVICE AND DISCONNECT THE FIRE.

If there is a fan or fan operated appliance in a nearby room then repeat the spillage test with the fan running and inter-connecting doors between the fan and the fire left open. If the fan and the fire are in the same room then repeat the spillage test with the fan on and doors and windows closed.

After the spillage testing has been performed re- fit the door mask.

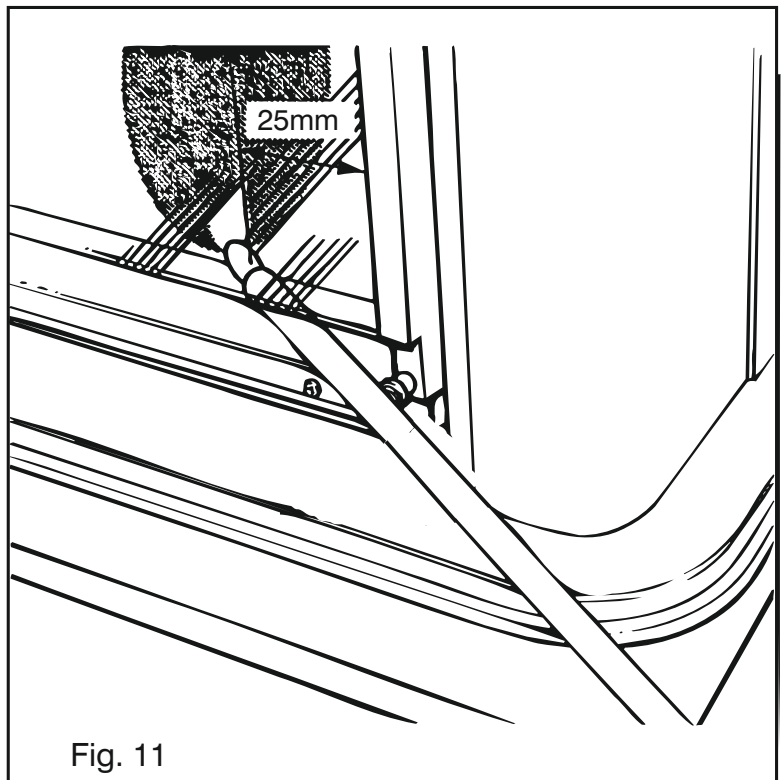

INSTALLATION

6.1 CHECK IGNITION

Check that ignition of the pilot and the cross-lighting to the main burner is satisfactory.

N.B. The spark gap between the electrode and thermocouple tip should be between 3.5 and 5.5mm (See Fig. 12).

6.2 CHECK OPERATION OF FSD

Leave the fire running on full rate for 5 minutes then turn off. After 3 minutes turn the gas tap to the full on position. If the gas has stopped flowing the FSD is satisfactory.

NOTE: You may hear the FSD valve close within the 3 minute period but always check that the gas has stopped flowing by turning the gas tap to the full on position.

Fig. 12

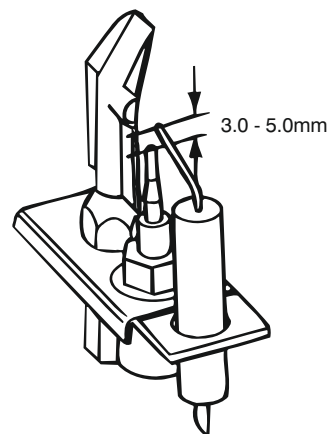

INSTRUCT USER

7.0 MAKE SURE THE USER KNOWS THAT:

1. The fire has a pilot burner and the control knob must be pressed in before turning to the pilot setting and kept pressed in for 10 seconds at this setting.
2. There are 4 heat settings apart from the pilot setting.
3. The fire can be lit with a taper if necessary as detailed in the users instructions.
4. When the fire is first lit a smell may be noticed but this should pass away after a few hours at the full on setting.
5. The fire should be serviced annually by a competent person i.e. Gas Safe registered Engineer, for continuing efficient and safe operation.
6. Advise the customer that they should read their Users instructions before operating the fire and always follow the advice in the Section headed "Cleaning your Fire".
7. The control knob adaptor may be fitted to assist with the operation of the fire (See Fig. 13). Leave with the User if not fitted.

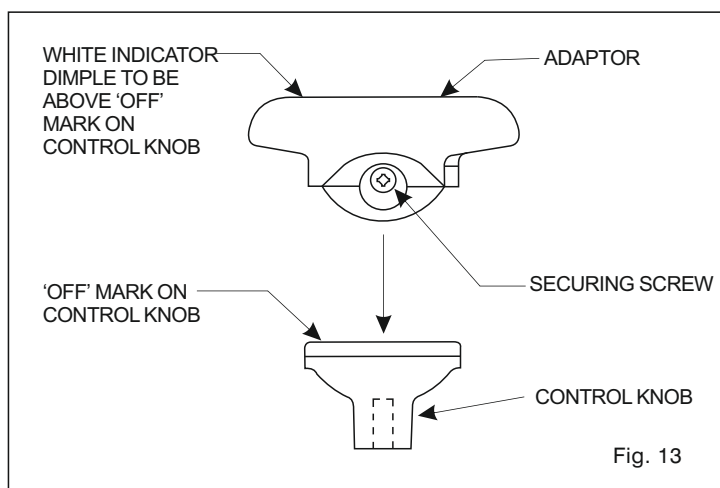

SERVICING INSTRUCTIONS

8.0 IMPORTANT NOTES

TURN OFF MAIN GAS TAP TO THE FIRE.

ALWAYS TEST FOR GAS SOUNDNESS AFTER SERVICING OR EXCHANGING ANY COMPONENT.

REMOVE THE FIRE FROM THE SURROUND AND CHECK FOR BUILD UP OF DEBRIS ON EVERY SERVICE VISIT.

CHECK THE FIRE FOR CLEARANCE OF PRODUCTS ON EVERY SERVICE VISIT.

N.B. To avoid damage to the coal bed and glass during servicing, it is recommended that these components are removed and put in a safe place.

8.1 REMOVAL OF OUTER COMPONENTS.

Remove the front panel by lifting upward and pulling forward. Pull out the control knob. Remove 4 screws 2 either side securing the outer case and lift the case away from the fire. Remove the glass door by withdrawing the 2 dome nuts securing it then removing the door bottom end first. Lift out the coal bed and put in a safe place.

8.2 GAS TAP/FSD ASSEMBLY

Remove the outer components (8.1 above)

- (A) Removal: Withdraw the lower spring clip securing the spindle extension to the gas tap spindle and remove. Disconnect the leads at the switch and the thermocouple nut at the bottom of the tap. Disconnect the tubing nuts on the inlet and outlet ports on the gas tap and remove the two fixing screws, manoeuvre the tap away from its pipework.
 - (B) Replacement: ensure the tap is in the off position before re-engaging it on its pipework in the fire. Re-assemble in the reverse manner ensuring that the spindle extension and knob align in the off position.
- NB: Make sure the spindle washer is on the spindle extension when re-assembling.

8.3 INJECTORS

Remove the outer components (8.1 above). Remove the pipes on the main outlets of the gas tap and remove the injectors from the burner. Replace the injectors and re-assemble in the reverse manner.

8.4 PILOT FILTER

Remove the outer components (8.1 above).

Remove the pipe connecting the pilot to the gas tap (2 nuts). The pilot filter is located in the outlet from the tap, prise it out with a pin. Insert a new pilot filter (it may be convenient to balance the new filter on the outlet and push home using a matchstick). Re-fit the pipe, tighten the nuts and check operation.

8.5 PILOT ASSEMBLY

The pilot is an atmosphere sensing device and must be replaced as a complete unit. Repair must not be undertaken.

NOTE: If the fire keeps going out or exhibits signs of nuisance shut off, check the operation of the pilot as follows:-

- (a) Inspect the pilot flame.
- (b) Check the thermocouple. If faulty replace the pilot assembly.
- (c) Check the magnetic unit in the gas tap. If faulty replace the tap.
- (d) Check the ventilation in the room. Vitiation may be due to lack of sufficient air supply.
- (e) Check for satisfactory clearance of combustion products. Vitiation may be due to spillage of combustion products into the room.

Remove the outer components (8.1 above). Disconnect the pilot feed tube at the pilot end. Remove the 2 screws securing the pilot to the main burner, pull the spark lead off the electrode and release the thermocouple nut at the gas tap. Remove the pilot feed pipe from the gas tap and pre-assemble the new pilot filter and feed pipe to the new pilot before fitting it in the fire. Re-assemble in the reverse manner.

NOTE: If the thermocouple, the electrode or the pilot itself are faulty, it is necessary to replace the whole pilot assembly. For ease of access, free the right hand fixing screw of the pilot shield strip.

PILOT LINT FILTER

A lint filter has been fitted to the pilot of this appliance to filter out any dust or lint which may present in normal household room air.

If you notice that the appliance has a floppy yellow pilot flame and/or there is difficulty in lighting the appliance then the lint filter may need cleaning. Cleaning should be carried out by vacuuming the dust and lint from the filter. If vacuuming alone is not successful in curing the ignition problem then a Gas Safe registered Engineer must be called to investigate the problem.

To remove the lint filter for cleaning or to gain access to the aeration hole simply slide the lint filter downward. Refit by pushing up against the pilot bracket, ensure it is crimped to hold it in place.

When supplied as a spare part the lint trap must be fitted as shown and crimped to fix in place, ensuring it is 'butted up' to the pilot bracket.

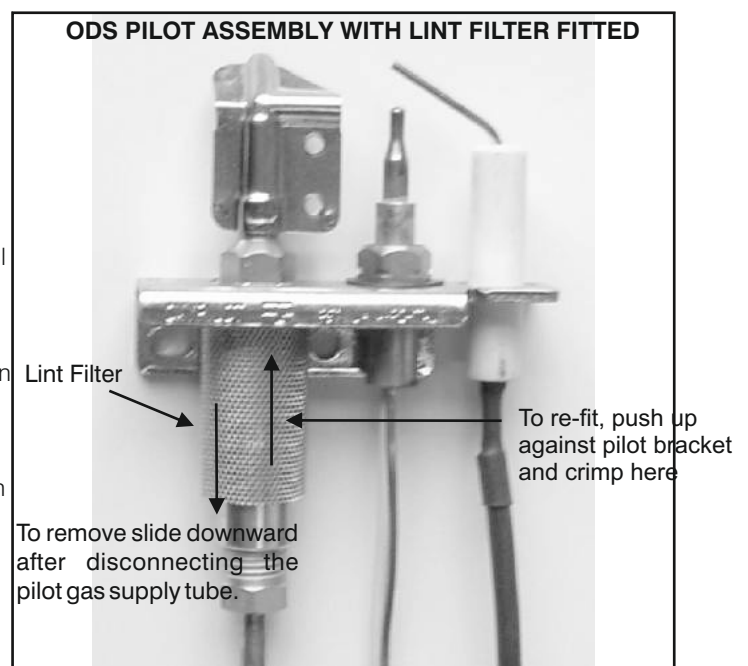

SHORT LIST OF PARTS

G.C. NUMBER	MAKERS PART NUMBER	DESCRIPTION
159 584 379 044	992495 822131 987632 987633	Pilot Assembly Pilot filter Ignition Lead Lead - switch/spark generator (2 off)
159 674 159 698	991860 992318 822240 991762	Door Assembly Coal Bed Gas Tap Assembly (c/w switch) Control Knob



Robinson Willey

GDC Group Ltd, Millbrook House, Grange Drive,
Hedge End, Southampton, SO30 2DF.

Telephone: 0844 879 35 88

E-mail: info@robinsonwilley.co.uk website: www.robinsonwilley.co.uk

Robinson Willey is a Trading Division of the GDC Group Ltd