

STOVAX

Fire Your Imagination

Riva Studio Duplex

Inset Convector Cassette



Instructions for Use, Installation & Servicing

For use in GB & IE (Great Britain & Republic of Ireland).

IMPORTANT

THE OUTER CASING, FRONT AND GLASS PANEL BECOME EXTREMELY HOT DURING OPERATION AND WILL RESULT IN SERIOUS INJURY AND BURNS IF TOUCHED. IT IS THEREFORE RECOMMENDED THAT A FIREGUARD COMPLYING WITH BS 8423:2002 IS USED IN THE PRESENCE OF YOUNG CHILDREN, THE ELDERLY OR INFIRM.

Do not attempt to burn rubbish in this appliance. Please read these Instructions carefully before installation or use.

Keep them in a safe place for future reference and when servicing the fire.

The commissioning sheet found on page 3 of these instructions should be completed by the Installer.



Contents

Riva Studio Duplex - Inset Convector

Covering the following models:

RVST-2DSHT

Appliance Commissioning Checklist	3
User Instructions	4
Getting Started	4
User Instructions	6
Care & Maintenance.....	7
Troubleshooting	10
Installation Instructions	12
Installation Checklist.....	12
Pre-Installation Instructions	15
Installing the Appliance.....	17
Commissioning	26
Maintenance & Servicing	28
Technical Appendix	31
Spare Parts List.....	35
Service Records	37



To receive your Extended Warranty your Stovax appliance must have been purchased from our Expert Retailer Network and registered within one month of purchase or installation. Please note that all warranties are effective from the date of purchase. Any Stovax product purchased outside of our Extended Retailer Network, or not registered within the stated time will carry a standard 12 month warranty.

It is a condition of the Extended Warranty that the installation complies with the relevant Building Regulations and is carried out by a suitably trained and qualified individual (HETAS in the UK or equivalent in other countries) with the certificate of installation and the Commissioning Report on Page 3 completed and retained by the end user.

Full terms and conditions are detailed in the Warranty Statement on the Stovax website www.stovax.com. In the event of any conflict of information the wording on the website shall prevail.

Important Note: Should any problems be experienced with your product, claims must first be submitted to the Expert Retailer where the appliance was purchased from who will offer immediate assistance or contact Stovax on your behalf.

DESIGN PROTECTION

The Studio design, including it's frames and accessories, are protected by European Design Registration
No. 001169338 0002 0008.



This appliance has been approved by HETAS Ltd.

Appliance Commissioning Checklist

To assist us in any guarantee claim please complete the following information:-

Dealer appliance was purchased from:

Name:

Address:

Telephone number:

Essential information - MUST be completed:

Date Installed:

Model Description:

Serial Number:

Installation Engineer:

Company Name:

Address:

Telephone number:

Commissioning Checks - to be completed and signed:

Is flue system correct for the appliance:	YES <input type="checkbox"/>	NO <input type="checkbox"/>
Flue swept and soundness test complete:	YES <input type="checkbox"/>	NO <input type="checkbox"/>
Smoke test completed on installed appliance	YES <input type="checkbox"/>	NO <input type="checkbox"/>
Spillage test completed	YES <input type="checkbox"/>	NO <input type="checkbox"/>
Use of appliance and operation of controls explained	YES <input type="checkbox"/>	NO <input type="checkbox"/>
Clearance to combustible materials checked	YES <input type="checkbox"/>	NO <input type="checkbox"/>
Instruction book handed to customer	YES <input type="checkbox"/>	NO <input type="checkbox"/>
CO Alarm Fitted	YES <input type="checkbox"/>	NO <input type="checkbox"/>

Signature: Print Name:

Getting Started

Welcome

Congratulations on purchasing your Stovax Riva Studio Duplex, if installed correctly Stovax hope it will give you many years of warmth and pleasure for which it was designed.

The purpose of this manual is to familiarise you with your stove, and give guidelines for its installation, operation and maintenance. If, after reading, you need further information, please do not hesitate to contact your Stovax retailer.

1. General Points

- 1.1 Before installation and/or use of this appliance please read these instructions fully and carefully to ensure that you have fully understood their requirements.

The appliance must be fitted by a registered installer*, or approved by your local building control officer.

- 1.2 All local regulations, including those referring to national and European Standards need to be complied with when installing the appliance.
- 1.3 Only use for domestic heating. To achieve the optimum performance from this appliance it must be installed and operated according to these instructions burning the fuels recommended.
- 1.4 You must burn only approved fuels. Do not use with liquid fuels or as an incinerator.
- 1.5 Appliance surfaces become very hot when in use. Use a suitable fireguard[‡] if young children, elderly or infirm persons are present. Stovax offer firescreens, sparkguards and hearthgate systems for protection. Your Stovax Retailer can advise you about these products.
- 1.6 Do not place photographs, TV's, paintings, porcelain or other combustible items on the wall or near the appliance. Exposure to hot temperatures will cause damage. Do not place furniture or other items such as drying clothing closer than 1m from the front of this appliance.
- WARNING:** Extra fuel should not be stored on or next to the appliance. Only keep enough fuel for immediate use nearby and never leave the appliance unattended for long periods with any combustible material in close proximity.
- 1.7 Extractor fans or cooker hoods must not be placed in the same room or space as this can cause appliance to emit fumes into the room.



‡In the U.K. these products must conform to the latest edition of BS 8423, Fireguards for use with solid fuel appliances.

If appliance is operating unattended they must conform to the latest edition of BS 3248

***Registered on the Competent Persons Scheme (GB only see page 34/ INFO (Republic of Ireland).**

- 1.8 Do not obstruct inside or outside ventilation required for the safe use of this appliance.
- 1.9 Do not make unauthorised changes to the appliance.
- 1.10 The chimney must be swept at least once a year. See Section 12.
- 1.11 Do not connect, or share, the same flue or chimney system with another appliance.

SERIAL NUMBER

- 1.12 This number is required when ordering spare parts or making warranty claims.

It is found on the appliance data plate, see Diagram 1.

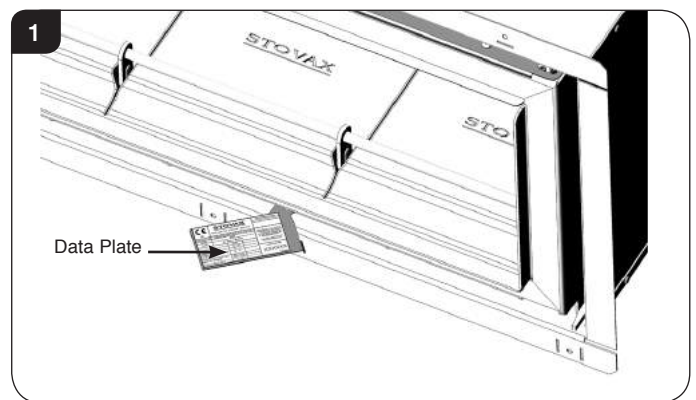

AIR CONTROLS

Triple Air Systems

Several Stovax appliances have triple air systems providing cleaner burning, and greater efficiency and control, see Diagram 2.

- 1) Airwash - air drawn over the window cleans the glass. The source of Primary Combustion air when burning wood.
- 2) Primary Air - for use initially when establishing fires.
- 3) Secondary Air - Secondary air is preheated through a heat exchanger to combust unburned hydrocarbons, providing a cleaner and more efficient burn.

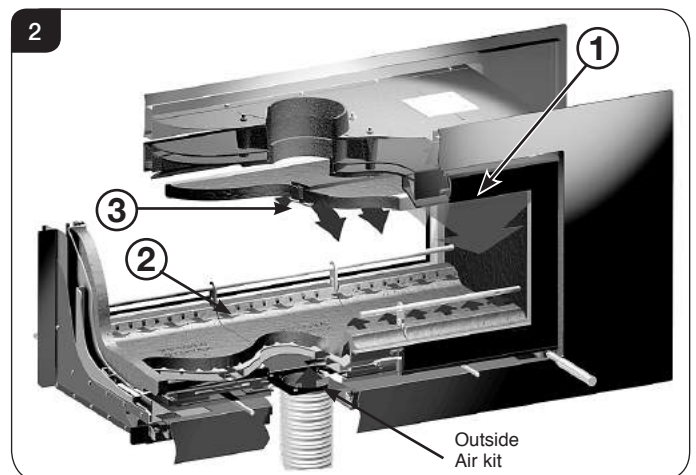

Getting Started

Airwash and Primary Air Controls

1.13 Use a protective gloved hand to operate.

DO NOT OPERATE THE AIR CONTROLS WITH BARE HANDS

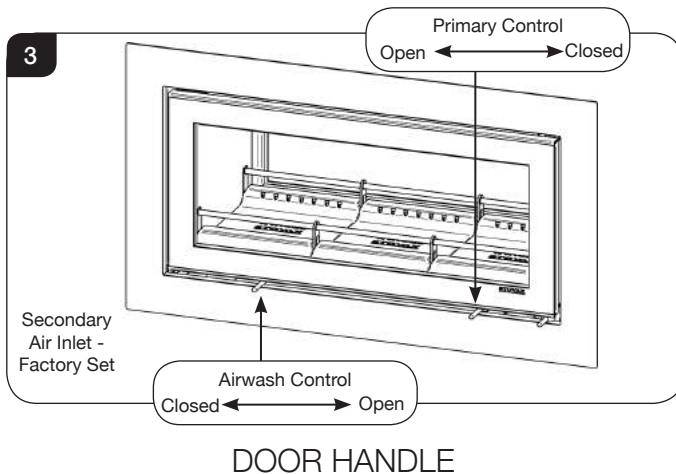

DO NOT OPEN THE DOOR WITH BARE HANDS

DO NOT OPEN THE DOORS WHEN THE FIREBOX IS FULL OF FLAMES - WAIT FOR THEM TO DIE DOWN.

MAIN DOOR

1.14 This is used to load and refuel the appliance. Use a protective gloved hand to open. Slide tool over knob to fit.

1.15 Move the slider to the left to open, see Diagram 4.

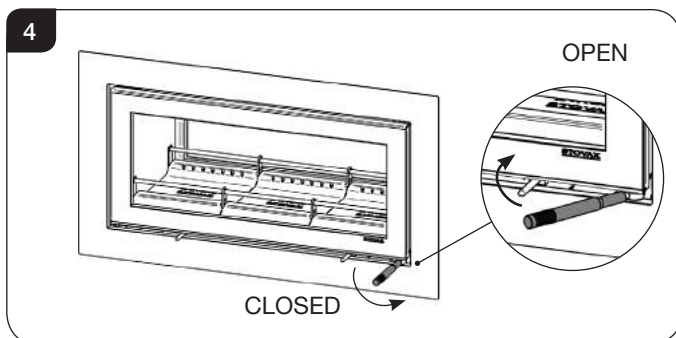

SECONDARY DOOR

1.16 The secondary door can be opened with the spanner supplied. This door is for servicing and cleaning the glass only.

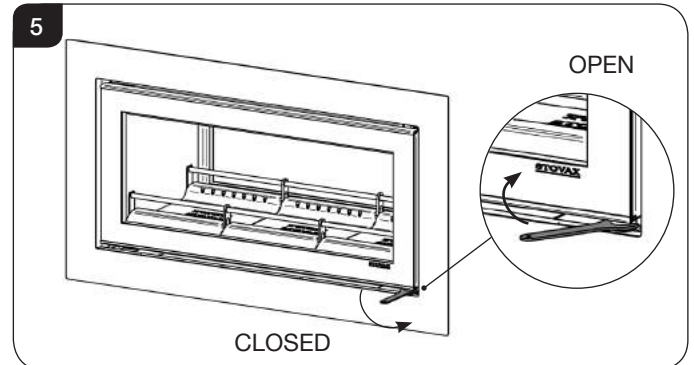

TO AVOID SPILLAGE INTO THE ROOM DO NOT OPEN BOTH DOORS AT THE SAME TIME.

WARNING



Properly installed, operated and maintained this appliance will not emit fumes into the room but occasional fumes from de-ashing and refuelling may occur.

Persistent fume emission is potentially dangerous and must not be tolerated.

If fume emission persists:

- Open doors and windows to ventilate the room.
- Leave the room.
- Allow fire to burn out or safely dispose of fuel from the appliance.
- Check for chimney blockage and clean if required.
- Do not attempt to relight until the cause of the emission has been identified and corrected.
- If necessary seek expert advice.

• All open flued appliances can be affected by temporary atmospheric conditions which may allow fumes to enter the house. Because of this an electronic carbon monoxide detector conforming to the latest edition of BSEN50292 must be fitted in the same room as the appliance. The existence of an alarm must not be considered a substitute for ensuring regular servicing and maintenance of the appliance and chimney system.

IF THE ALARM SOUNDS FOLLOW THE INSTRUCTIONS GIVEN ABOVE.

Getting Started/User Instructions

2. Using the Appliance for the First Time

- 2.1 To allow the appliance to settle, and fixing glues and paint to fully cure, operate the appliance at a low temperature for first few days.
- 2.2 Do not touch the paint during the first period of use.
- 2.3 During this time the appliance may give off some unpleasant odours. Keep the room well ventilated to avoid a build-up of fumes.
- 2.4 Please be aware that, during use, rope seals may discolour. This is normal.

3. Recommended Fuels

3.1 Wood Logs:

Burn only seasoned timber with a moisture content of less than 20%. To ensure this allow cut wood to dry for 12 to 18 months.

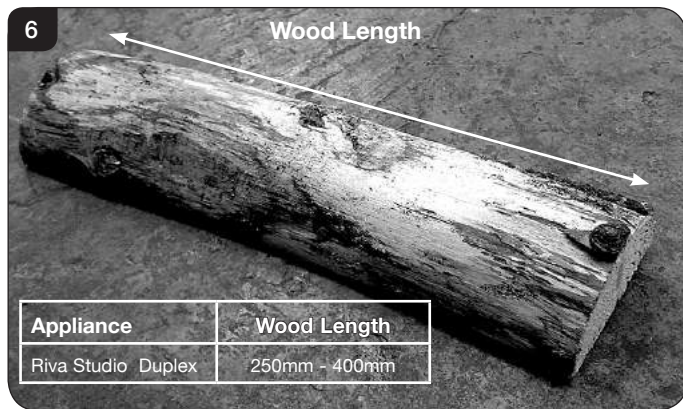

Poor quality timber:

- Causes low combustion efficiency
- Produces harmful condensation
- Reduces effectiveness of the airwash and life of the appliance

Do not burn construction timber, painted, impregnated / treated wood, manufactured board products or pallet wood.

3.2 Fuel consumption.

As tested at nominal heat output to the requirements of EN 13229: 2001 for intermittent operation:

Description	Fuel Consumption
	Kg/hour Wood
Riva Studio Duplex	3.6

A number of factors can affect the performance of the appliance, see Troubleshooting Section for details.

Fuel Overloading

The maximum amount of fuel specified in this manual should not be exceeded, overloading can cause excess smoke.

4. Lighting the Appliance

- 4.1 For best results set air controls as shown, see Diagram 7.

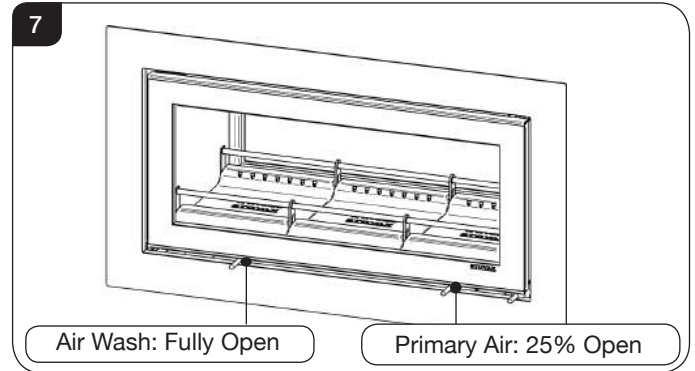

- 4.2 Place firelighters or paper and dry kindling wood on the base bricks.

A successful fire initially requires plenty of kindling to establish a hot firebox and warm the chimney to aid flue performance.

- 4.3 Light the paper or firelighters, see Diagram 8.
- 4.4 Leave the door slightly open as the fire establishes and the glass warms to avoid build up of condensation.



- 4.5 Add larger pieces of wood. Do not use full sized logs at this stage, build up gradually in size. Too many logs may smother the fire.

Fuel Loading:

These are wide appliances and the logs should be laid out in a single layer with gaps between, see Diagram 9.

Do not stack the logs on top of each other as this could effect the efficiency. DO NOT OVERLOAD THE APPLIANCE AS THE HEAT OUTPUT WILL BE TOO HIGH.

Be sure to use split logs and not whole pieces of wood. Too much fuel in the firebox will cause the appliance to reach higher temperatures than intended. This can damage the interior components of the fire.

Suggested Loads:

3/4 logs no bigger than 5" (127mm) diameter

User Instructions/Care & Maintenance

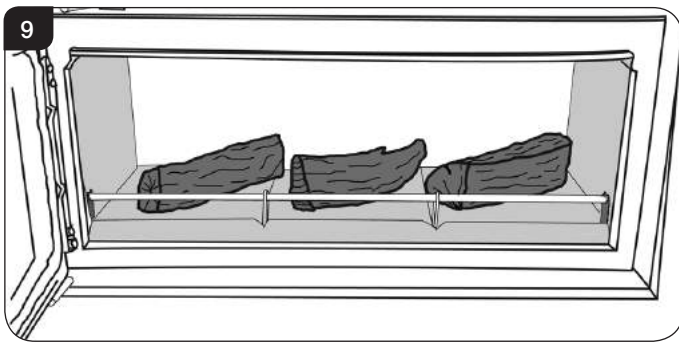

- 4.6 Close the door and follow the instructions for Running the Appliance.
Do not run with the door slightly open except for initial lighting as this could cause over-firing and damage the appliance.

WARNING: DO NOT OPERATE THE APPLIANCE WITH THE PRIMARY AIR CONTROL OPEN FOR LONG PERIODS OF TIME AS THIS COULD CAUSE OVER-FIRING AND MAY CAUSE PERMANENT DAMAGE.

5. Running the Appliance

Burning Wood

- 5.1 Close the **Primary air control** and use the **Airwash** to control the burn rate when appliance is at operating temperature, see Diagram 10.

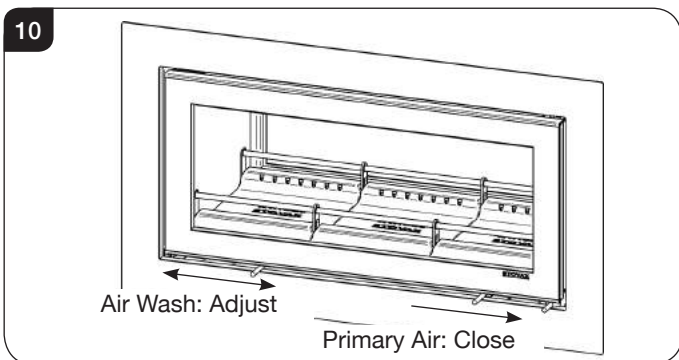

Wood burns best on a bed of ash (approx. 25mm (1") deep).

- 5.2 Do not burn large amounts of fuel with the **Airwash Control** closed for long periods of time. This reduces the glass cleaning effect of the Airwash and causes tars and creosotes to build-up in the appliance and flue system.
- 5.3 When in use, burning the appliance at a high temperature for a short period reduces tars and creosotes.
WARNING: DO NOT OPERATE THE APPLIANCE WITH THE PRIMARY AIR CONTROL OPEN FOR LONG PERIODS OF TIME AS THIS COULD CAUSE OVER-FIRING AND MAY CAUSE PERMANENT DAMAGE.
- Experience establishes settings to suit personal preference.
- 5.4 **In order to achieve the nominal heat output of 9kW Stovax recommends the controls are set to:**
Airwash: 100%
Primary Air: Closed

Refuelling

- 5.5 Toward the end of the burn cycle open the **Primary Air control** for a few minutes. This increases the temperature of the ashbed, helping re-ignition of the new logs and keeps the ash to a minimum.
- 5.6 Rake the embers evenly over the firebed and open the **Airwash Control** fully for a few minutes before re-fuelling. If the firebed is low add a small amount of kindling wood to help re-establish the fire.
- 5.7 **Do not refuel when a large amount of flames are in the firebox as this could cause smoke or flames to spill into the room.**
- 5.8 **Close the doors immediately after refuelling.**

These are wide appliances and the logs should be laid out in a single layer with gaps between, see Diagram 9.

Do not stack the logs on top of each other as this could effect the efficiency. DO NOT OVERLOAD THE APPLIANCE AS TOO MUCH FUEL COULD CAUSE IT TO OVER-FIRE.

- 5.9 After refuelling:
Burn the new logs at high output for a few minutes before closing the Primary Air control. Adjust the burn rate using the Airwash control.
- Do not close the air controls until the fire is burning well.**
- 5.10 **Do not burn large amounts of fuel with the Airwash control closed for long periods of time.** This reduces the glass cleaning effect, causes tars and creosotes to build-up in the appliance and flue system and will produce excessive amounts of smoke.
- 5.11 When running the appliance **refuel little and often for clean, efficient burning.**
- A bright and clean firebox indicates the appliance is burning well.**
- 5.12 **Do not burn continuously with the door open.**

Shut Down

- 5.13 If there is still burning fuel in the firebox, Stovax do not recommend shutting down the air controls completely unless there is a chimney fire in progress (see Section 9 for advice). Closing the controls during the burning process will cause poor combustion and could lead to a build up of gasses that could ignite dangerously.
- 5.14 Always have enough air entering the appliance to maintain some flame within the firebox.
- 5.15 If it is necessary to shut down the appliance then run on a high setting until all of the fuel has been burnt before closing the air controls.

Care & Maintenance

6. Extended Burning

- 6.1 It is possible to get the appliance to burn for extended periods of time. In order to do this:
- De-ash prior to final refuelling.
 - Burn new fuel at a high temperature for a few minutes before closing the **Primary Air Control**.
 - Set air controls to low combustion settings.
This will gradually blacken the glass but it will clear when operated at a high temperature for a short period.

7. Ash Removal

- 7.1 Wood burns best on a bed of ash (approx. 25mm (1") deep). **Do not allow ash to build up in the appliance as it will not burn properly and may cause damage.**
- 7.2 Open door, see Diagrams 4&5 on page 5.
Remove ash with a small shovel (available from Stovax). Take care not to damage the ceramic lining of the appliance. Do not use sharp pointed pokers.
- 7.3 Remove ash carefully - heat can remain long after use.
- 7.4 Carefully place the ash into a Stovax Ash Caddy (Stovax Part No. 4227).
- 7.5 Do not place hot ash in a container made from plastic or any other combustible material.

8. Over-Firing

- 8.1 Do not over-fill with fuel or run at high temperatures for long periods or over-firing can occur.
DO NOT OPERATE THE APPLIANCE WITH THE PRIMARY AIR CONTROL OPEN FOR LONG PERIODS OF TIME AS THIS COULD CAUSE OVER-FIRING AND MAY CAUSE PERMANENT DAMAGE.
- 8.2 **Over-firing can cause permanent damage to the appliance and invalid the product warranty.**

9. Chimney Fire

- 9.1 **If a chimney fire occurs:**
- Shut all air controls immediately.
 - Evacuate the building.
 - Call the fire brigade.
 - Do not re-enter the building until it is confirmed safe.
- 9.2 **Do not use the appliance after a chimney fire until:**
- It has been inspected by a registered installer*, confirming the appliance is safe to use.**
 - The chimney system has been inspected and swept by a chimney sweep, confirming the system is structurally sound and free from obstruction*.
 - It is repaired as required before re-use.** Use only genuine Stovax replacement parts to keep your appliance in safe, efficient working order.

10. General Cleaning

- 10.1 Clean and inspect the appliance regularly, especially in periods of heavy use. Regular cleaning and maintenance will help give many years of safe use.
- 10.2 **Allow appliance to cool thoroughly to avoid risk of burns.**
- 10.3 Clean regularly, according to level of use.
- 10.4 Remove the ash completely, see User Instructions, Section 7.
- 10.5 Check internal components for damage - grates, bricks, baffles - and for obvious build up of soot, ash or debris above the flue baffle(s) (these can be found in the upper part of the firebox). Use a torch if necessary.
- 10.6 If there are any signs of a build up of debris above the flue baffle(s) either:
- Arrange for the chimney to be swept, see User Instructions, Section 12.
 - Remove the baffles and clear the debris, see Pre-Installation Sections.
- 10.7 To refresh painted finishes a touch up spray is available. Contact your Stovax retailer quoting the serial number found on the appliance date badge.

Do not use aerosol sprays near an operating appliance.

11. Cleaning Glass

- 11.1 Keep the glass clean with correct use of the Airwash system and good quality fuel. Use the boost setting to clear any build up.
- 11.2 Sometimes additional cleaning may be required. Before undertaking this operation allow appliance to cool fully. Do not clean hot glass.
- 11.3 **On appliances with printed glass do not use cleaning agents that have a high alkaline or acidic content, for example Stovax Gel Cleaner, these are aggressive cleaning agents designed to be used with heavily stained clear glass. On printed glass surfaces, use Stovax Glass Cleaner (Stovax No.4103) which is better formulated for this application.**
- 11.4 Before applying a cleaning agent remove any dust and loose soot with a damp cloth.
- 11.5 Use an appropriate glass cleaner. Apply the cleaning fluid to a cloth before rubbing onto the glass. Apply carefully and do not apply excessively. Try to prevent any run off which could soak into the rope seals around the edge of the glass.
Soot can also contain acidic particles that can cause corrosive damage to printed glass.

 ***Registered on the Competent Persons Scheme (GB only) see page 34/ INFO (Republic of Ireland).**

Care & Maintenance

- 11.6 Remove dirt with a moist cloth and buff dry.
- 11.7 **Some types of wood can cause a white residue to form on the glass.**
If this occurs it should be cleaned off at least once a week during periods of heavy usage.
If the liquid cleaning agents recommended do not remove this residue Stovax offer a dry cleaning pad which will help remove heavy stains.
- 11.8 Before relighting the appliance ensure the glass is fully dried. If the rope seal has absorbed excess cleaning agent it is advisable to replace the rope as soon as possible to preserve the printed finish of the glass.

12. Chimney Sweeping

- 12.1 To maintain safe and efficient use of the appliance, the chimney/flue must be inspected and swept at least once a year by a qualified chimney sweep*.
- If the appliance is used continuously throughout the year, or it is used to burn wood, more frequent sweeping is recommended.
- The best time to have the chimney swept is at the start of the heating season.
- 12.2 The chimney, any connecting flue pipe and the appliance flue ways, if incorporated, must be regularly cleaned.
- 12.3 Ensure adequate access for cleaning where it is not possible to sweep through the chimney.
- 12.4 If the chimney is believed to have previously served an open fire it must be swept a second time within a month of regular use after installation.

13. Care Of Stove

Stovax has a range of cleaning and maintenance products and accessories to keep your appliance in good working order. Your Stovax retailer can advise you on suitable items for your stove and provide genuine spare parts such as replacement glass, door sealing rope and firebricks. View the extensive range at www.stovax.com by clicking on Accessories. In addition, an annual service by a competent engineer is recommended to keep your stove in the best possible condition.



14. Seasonal Use

- 14.1 Clean and service the appliance if not used during the warmer months, as detailed in the Maintenance and Servicing section.
- 14.2 Set the air controls to 50% to keep the appliance ventilated and stop the build-up of any moisture inside.
- 14.3 Before re-lighting the appliance:
- Remove the baffles.
 - Clear any debris that may have accumulated.
 - Check the flue is clear of any blockages.

15. Optional Extras

Dedicated External Air Supply Kit

- 15.1 The Stovax Duplex has a dedicated air system that allows the supply of air directly to the appliance without the need for an air brick to be added to the room where it is installed for additional ventilation.
- However due to conditions in the current edition of Building Regulations, a registered HETAS installer cannot sign off such an installation. If you wish to avoid fitting an air brick by using the Stovax Dedicated Outdoor Air System, it will be necessary to contact your local Building Control Officer who will be able to sign off the installation provided it meets the requirements of the manufacturer.

The Stovax Studio Duplex can be converted for use with a sealed dedicated external air supply by the addition of an optional kit:
Stovax Code: RVS-2DSAIR (ask your retailer for details). This innovative feature removes the need for a permanently open air vent into the room, eliminating draughts and improving heating efficiency.

This system is designed so that when the Duplex door is opened for refuelling it also opens a vent into the room providing sufficient ventilation to comply with the requirements of the Building Regulations †.

Warm Air Ducting Kit

- 15.2 This appliance can be fitted with an optional Warm Air Ducting kit to help circulate warm air to other room in the house.
Stovax Code: 8572 (ask your retailer for details). This operation may require additional ventilation in order to comply with building regulations and a qualified installer should be consulted before fitting.
The Ducting kit must be fitted at the time of installation. For installation and operating procedures you must refer to the instructions supplied with the Warm Air Ducting kit - Stovax Part No PM509.

i † England and Wales – Document J / Scotland - Part F/Document J (Republic of Ireland only)

Troubleshooting

Troubleshooting

	Symptom	Cause	Solution
OPERATION	Difficulty starting the fire and keeping it burning well	Low flue draught	Consult your installer
		Wet wood (over 20% moisture)	Use dry seasoned wood (less than 20% moisture content)
	Poor burning control	High flue draught	Consult your installer
	Short burn times	Wet wood (over 20% moisture) Insufficient amount of fuel - Refer to the table in section 3	Use dry seasoned wood (less than 20% moisture content)
	Excessive heat output (Over firing)	High flue draught	Consult your installer
		Air control left fully open	Close air control to reduce output
	Low heat output	Low flue draught	Consult your installer for advice on suitable flue system
		Wet wood (over 20% moisture)	Use dry seasoned wood (less than 20% moisture content)
	Excessive fuel consumption	High flue draught	Consult your installer for advice on suitable flue system
		Over dry wood	Do not use constructional timber or pallet wood
SMOKE EMISSIONS	Smoke and small flames	Wet wood (over 20% moisture)	Use dry seasoned wood (less than 20% moisture content)
	Intermittent smoke spillage into room when appliance door is opened	Low flue draught	Consult your installer for advice on suitable flue system
		Incorrect additional ventilation air in to building	Consult your installer
	Continuous smoke spillage into room when appliance in use	Blocked flue	Open all doors and windows to ventilate the room. Allow the fire to burn out. Check flue for blockage. Do not re-use until cause of spillage is identified. Consult your installer for advice
Blue/grey smoke from chimney	Wet wood (over 20% moisture)	Use dry seasoned wood (less than 20% moisture content)	
ADVERSE WEATHER	Windy days, intermittent smoke spillage into room when appliance door is opened	Down draught in flue caused by air turbulence caused by nearby buildings or trees	Weather conditions combined with the flue terminal position can have an effect on the appliance performance. Consult your installer
	Calm days, intermittent smoke spillage into room when appliance door is opened	Over size flue giving poor flue draught	Weather conditions combined with the flue terminal position can have an effect on the appliance performance. Consult your installer
	Damp/Rainy days lighting and burning problems	Flue temperature low / rain water inside flue	Use good quality wood to start and maintain the fire, consult your installer to fit a rain cowl
	Wind noise from the air control	High flue draught	Consult your installer for advice on suitable flue system

Troubleshooting

	Symptom	Cause	Solution
THE APPLIANCE	Rapid creosote build-up in the chimney	Wet wood (over 20% moisture)	Use dry seasoned wood (less than 20% moisture content). Operate at a high temperature for short periods each time the appliance is used to avoid large build-ups of tars and creosotes
	Tar coming from flue joints	Appliance operated at continuous low temperatures	Operate at a high temperature for short periods each time the appliance is used to avoid large build-ups of tars and creosotes. See user instructions for correct use of air control
		Using poor quality wood	Use dry seasoned wood (less than 20% moisture content)
	Strong pungent smell after the appliance is lit	Appliance operated at continuous low output	Operate at high output for short periods. See user instructions for correct use of air control
		Using poor quality wood	Use dry seasoned wood (less than 20% moisture content)
	Wind noise from the air control	High flue draught	Consult your installer for advice on suitable flue system
	Dirty firebricks	Wet wood (over 20% moisture)	Use dry seasoned wood (less than 20% moisture content)
	Dirty glass	Wet wood (over 20% moisture)	Use dry seasoned wood (less than 20% moisture content)
	Glass blackening	Using poor quality wood	Use dry seasoned wood (less than 20% moisture content)
		Low flue draught	Consult your installer for advice on suitable flue system
Incorrect use of air control		See user instructions for correct use of air control	
Appliance operated at continuous low temperatures		Operate at high output for short periods. See user instructions for correct use of air control	

FLUES	The flue system has two main functions:
	<ul style="list-style-type: none"> - To safely remove the smoke, fumes and combustion gases from the building. - To provide a sufficient amount of flue draught (suction) in the appliance to ensure the fire keeps burning.
	The flue draught is caused by rising hot gases when the appliance is lit.
	Tar and creosote are a major cause of chimney fires. If the appliance experiences problems with tar build up consult a chimney sweep before continued use of the appliance.
	For advise on the correction of persistent flue problems consult a qualified heating engineer before continuing to use the appliance.

Installation Checklist

Please Note

This section is intended to give an overview of the product performance and essential information required for installing the appliance. It is intended for qualified engineers who are already familiar with Stovax products.

For full details and expanded information please see the Technical Appendix at the back of this manual.

1. Riva Studio Dimensions

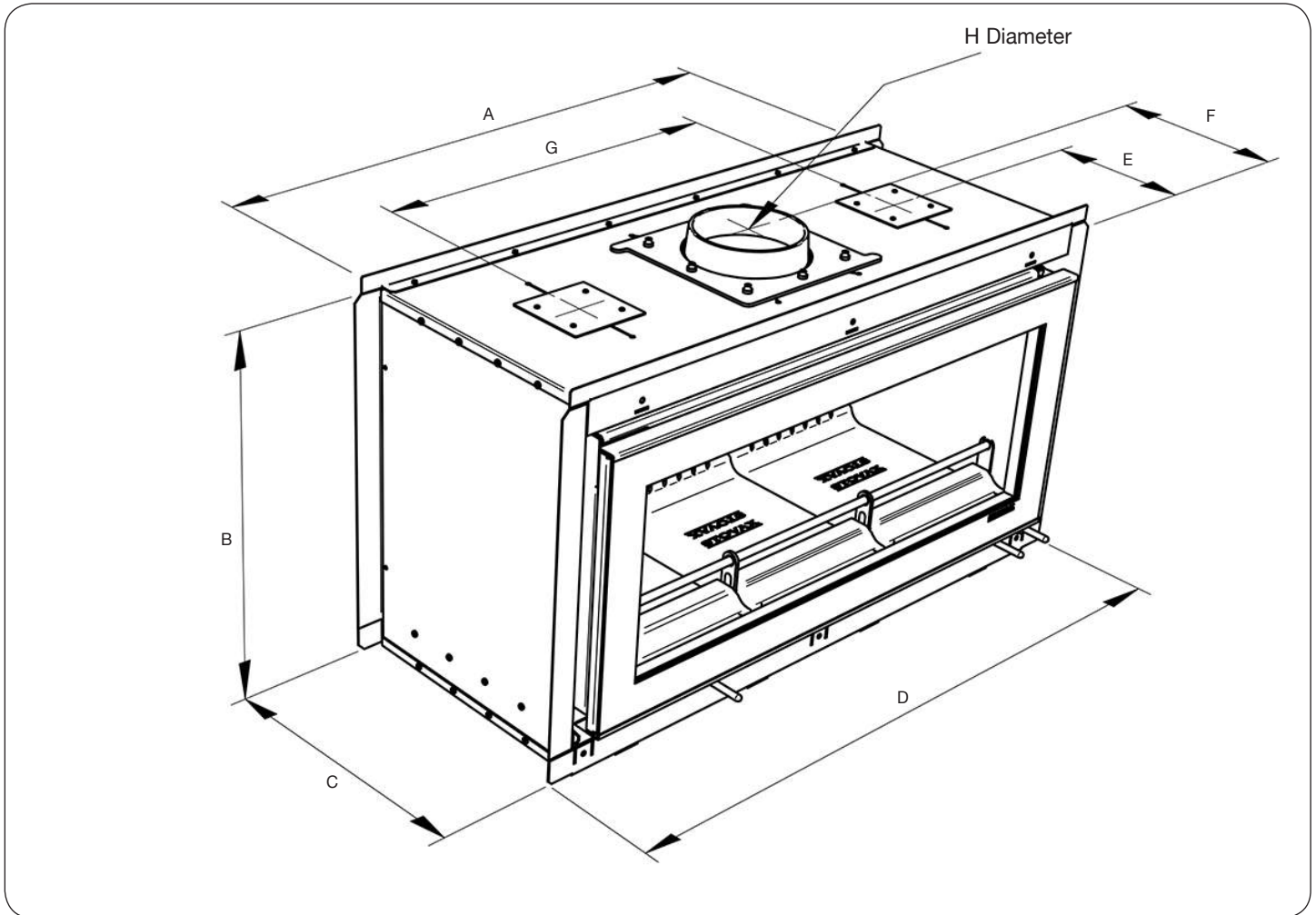

Description	Model	A	B	C	D	E	F	G	H
Riva Studio Duplex	RVST-2DSHT	950	550	402 -414	1020	200	200	610	153 (6")

All dimensions in mm. (25.4 mm = 1")

Installation Checklist

2. Essential Information

GENERAL	Model:	Riva Studio Duplex		Riva Studio Duplex
	Nominal Heat Output	Wood	kW	9.0
	Efficiency	Wood	%	75
	CO @ 13% O ₂	Wood	%	0.29
	Weight		Kg	144
Recommended Fuels	Wood	Seasoned Wood (less than 20% moisture content)		

As tested to the requirements of EN 13229 for intermittent operation

FLUES	Flue/Chimney Size	With Liner of Factory made system (diameter) installed in accordance with manufacturers instructions	mm	153
			inch	6
	Flue/Chimney minimum height**	All products <small>**must be 4.5m from the hearth to the top of the flue, with no horizontal sections and a maximum of 4 bends. Bends must have angles of less than 45 degrees from the vertical.</small>	m	4.5
			feet	13
	Flue Draught	Min	mm Wg	1.0
		Nominal		1.5
		Max		2.0
	Flue Gas Mass Flow	Wood	g/s	8.6
Flue Gas Temperature at Spigot/Socket	Wood	°C	346	
Flue Outlet Size (Top Option)		mm	153	
		inch	6	

European Min Spec for Chimney Flue - T400 NZ D3 G

VENTILATION	A) Traditionally Built Homes		B) Modern Construction Homes	
	• Where leakage is greater than 5m ³ /hour/m ² .		• Where leakage is less than 5m ³ /hour/m ² .	
	• Ventilation normally required = 550mm ² per kW output over 5kW		• Ventilation normally required = 550mm ² per kW	
	A	Additional Ventilation	mm ²	1650.00
			cm ²	16.50
			in ²	2.66
B	Additional Ventilation	mm ²	4400	
		cm ²	44.00	
		in ²	7.10	

Note: The above ventilation can be provided by the innovative dedicated Sealed External Air system

For full technical details on ventilation see Technical Appendix on Page 31

i In the U.K. Additional information covering the installation of the appliance may be found in the following British Standards: BS EN 15287-1, BS6999, BS8303.

Installation Checklist

3. Minimum Dimensions - Hearth Both Sides

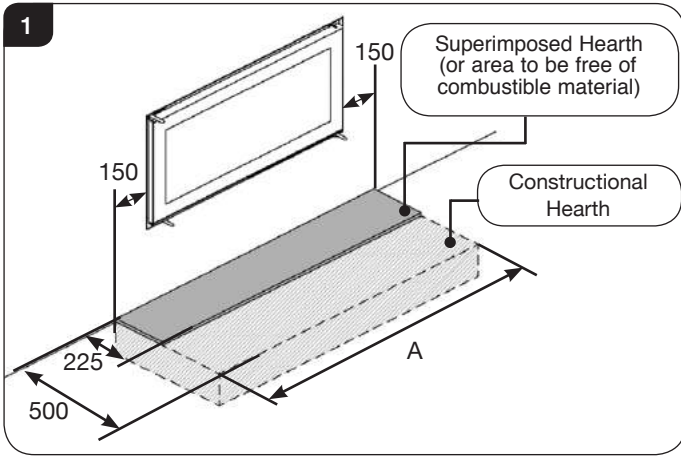

Dimension	A
Riva Studio Duplex	1250

4. Clearances to combustibles

When fitting the appliance use the minimum clearances between any point of the appliance and any combustible material.

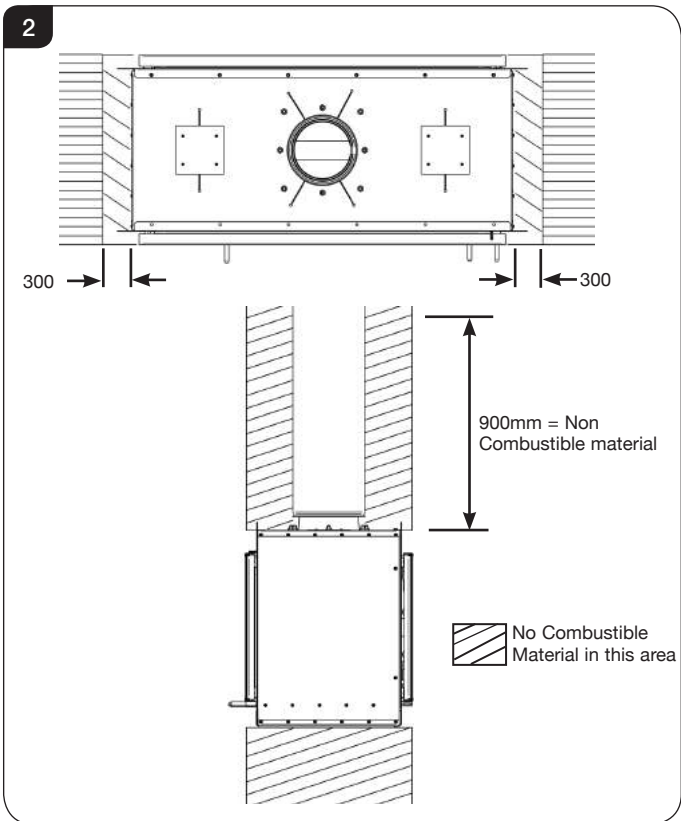

5. Optional Extras

The Duplex has a number of optional extras to enhance the performance of the appliance. These need to be considered when planning the installation.

Dedicated External Air Supply Kit

- 5.1 The Stovax Duplex has a dedicated air system that allows the supply of air directly to the appliance without the need for an air brick to be added to the room where it is installed for additional ventilation. However due to conditions in the current edition of Building Regulations, a registered HETAS installer cannot sign off such an installation. If you wish to avoid fitting an air brick by using the Stovax Dedicated Outdoor Air System, it will be necessary to contact your local Building Control Officer who will be able to sign off the installation provided it meets the requirements of the manufacturer.

The Stovax Studio Duplex can be converted for use with a sealed dedicated external air supply by the addition of an optional kit: Stovax Code: RVS-2DSAIR (ask your retailer for details). This innovative feature removes the need for a permanently open air vent into the room, eliminating draughts and improving heating efficiency.

This system is designed so that when the Duplex door is opened for refuelling it also opens a vent into the room providing sufficient ventilation to comply with the requirements of the Building Regulations †.

Warm Air Ducting Kit

- 5.2 This appliance can be fitted with an optional Warm Air Ducting kit to help circulate warm air to other room in the house. Stovax Code: 8572 (ask your retailer for details). This operation may require additional ventilation in order to comply with building regulations and a qualified installer should be consulted before fitting. The Ducting kit must be fitted at the time of installation. For installation and operating procedures you must refer to the instructions supplied with the Warm Air Ducting kit - Stovax Part No PM509.



† England and Wales – Document J / Scotland - Part F/Document J (Republic of Ireland only)

Pre-Installation Instructions

1. General

- 1.1 To make the installation of the appliance easier it is best to remove the internal components before fitting into the builders opening/studwork.
- 1.2 For the best results removing the following components as set out below.

2. Removal of the Door Both Sides

Before removing the doors it is recommended to protect the left edge from damage using masking tape.

Both doors are removed using the same method.

It is recommended that both doors are removed at this stage to avoid damage during installation.

- 2.1 Open the door approximately 90°, see Diagram 1.

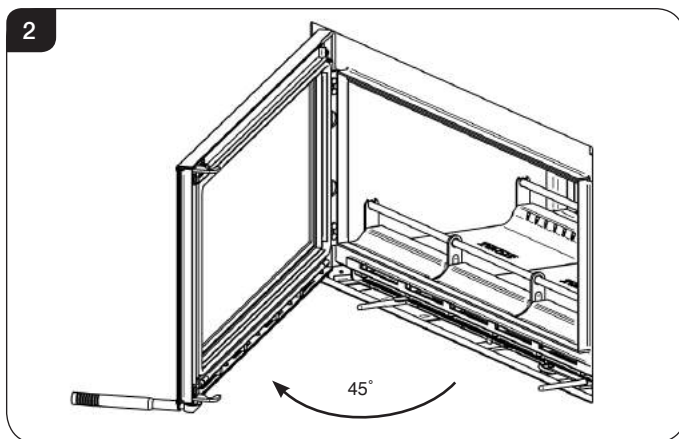
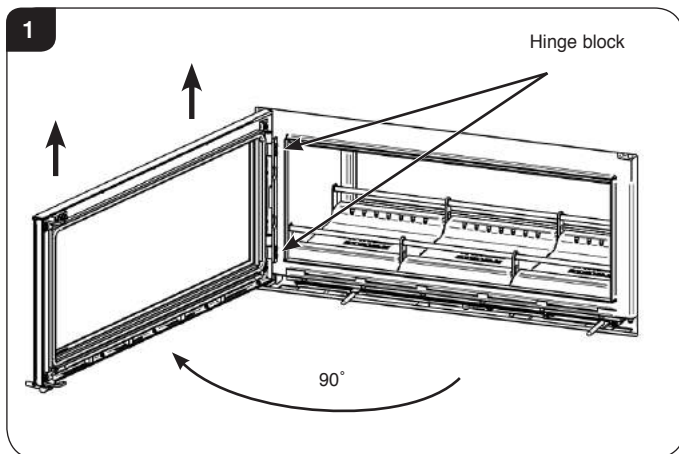

- 2.2 Lift the door vertically to remove from the hinge block, see Diagram 1.
- 2.3 Close the door 45°, see Diagram 2 and carefully manoeuvre the door clear of the hinge mechanism.

- 2.4 Lie the door face down on a soft flat surface to protect the paint work and glass.
- 2.5 Reverse the procedure to re-fit the door.

3. Removal of Internal Components

In the firebox of the appliance are several loose items including:

- A box containing:
 - Baffle Bricks
 - Firebricks
 - Bag containing Instruction Manual, Warranty & Door Tools
 - Log Guard End Supports
- Log Guards x 2
- Front Baffle Supports x 2

- 3.1 Remove these carefully and put them safely to one side. They can be fitted after the appliance has been installed, see Installation Section.

4. Separate the Inner & Outer Box

To protect the delicate parts of the appliance the product has been designed so that the inner box can be removed from the outer box.

Keep the inner box in a safe place whilst the outer box is installed into the fabric of the house, the main flue connections made and the walls finished.

When all the heavy work is complete the inner box can be re-installed into the outer box and the final connection made.

- 4.1 The internal components, bricks, baffles and the door etc should be removed to make the installation process easier and prevent damage.
- 4.2 First remove the inner collar, see Diagram 3.

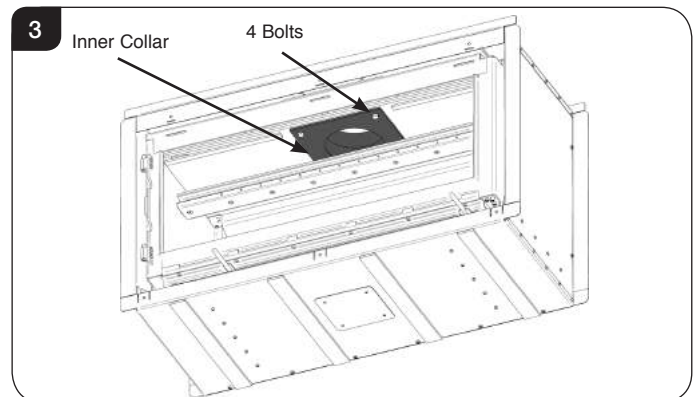

Pre-Installation Instructions

- 4.3 First remove the inner collar. Using a 13 A/F spanner, remove the 4 x bolts, see Diagram 4.

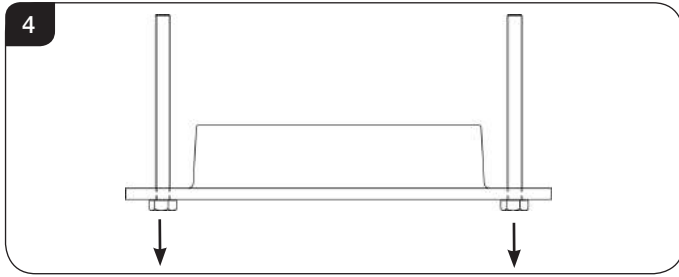

- 4.4 The inner box can now be slid out of the outer box.
The inner box can only be removed from the opening opposite the side with the adjustable flange and bolts, see Diagram 5.

This will require at least two people.

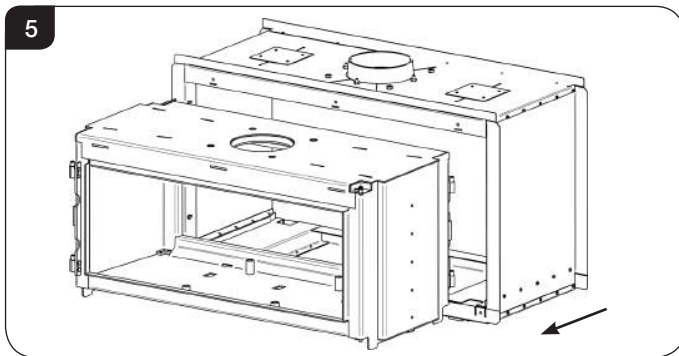

Installation Instructions

1. Installing the Appliance

Each installation is unique to the property so it is not possible to give details to suit every setting. The installation must comply with Building Regulations† and be made using "best practice" construction methods‡.

Stovax Studio models can reach high temperatures. Pay careful attention to the distance to combustible materials recommended and ensure the housing for the appliance is built from non-combustible material.

Do not support the structure with the appliance or the flue system.

- 1.1 **Take care when installing the appliance. Careless handling and use of tools can damage the finish and/or area.**

Stovax recommends this appliance is installed into a purpose built metal Studwork construction.

Do not attempt to retrofit this appliance into an existing opening.

Frame Bracket

- 1.2 This method of installation will require the attachment of frame fixing brackets prior to the installation of the outer box. See Diagram 1.

See the frame fitting instruction for the individual fixing methods. (Not required if Edge or Cool Wall frames are fitted)

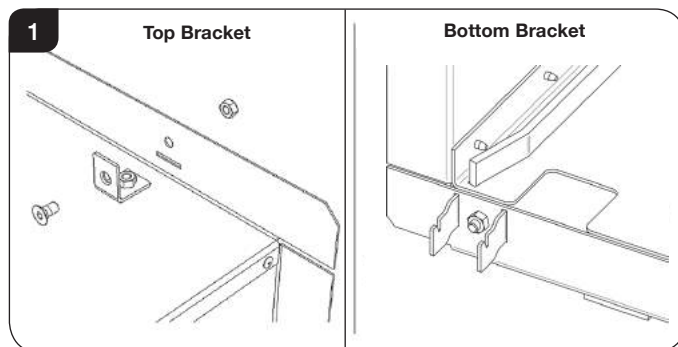

- 1.3 **Fit frame fixing brackets or Edge/Cool Wall frame as required. See alternative frame instructions (PM378) for individual fixing methods.**

- 1.4 The outer box can now be installed into a studwork wall.

i † England and Wales – Document J / Scotland - Part F/Document J (Republic of Ireland only)
‡ the latest edition of BS 8303, BS EN 15287, BS 7566

2. Studwork Installation

- 2.1 **DISTANCE TO COMBUSTIBLE MATERIAL**

ALL PARTS OF THE STUDWORK MUST BE NON COMBUSTIBLE - FOR EXAMPLE METAL STUDDING. DO NOT USE COMBUSTIBLE MATERIAL WITHIN THE DIMENSIONS BELOW.

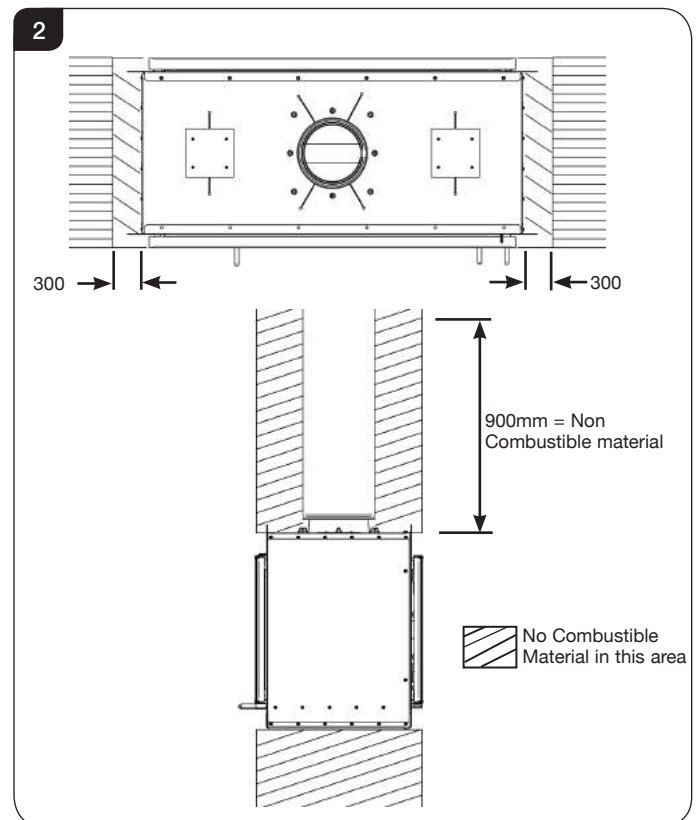

- 2.2 **Do not pack the void around or above the appliance with insulation materials such as mineral wool or vermiculite.**
- 2.3 **The void built for the appliance must be ventilated to prevent a build up of heat. If the void is sealed then you must fit vents at both low and high levels of approximately 200cm² each. These vents must take cold air from the room and return warm air back into the room.**
- 2.4 **An access hatch must be left in the side of the studwork for future servicing and inspection of the flue and appliance.**
- 2.5 If constructing studwork for an Edge or Cool Wall finish consult the following sections before proceeding:
Section 5 Frameless Edge and Edge Plus
Section 6: Cool Wall

Installation Instructions

2.6 When constructing the framework for the Duplex the following dimensions must be observed to create the correct sized opening to fit flush to the appliance, see Diagram 3.

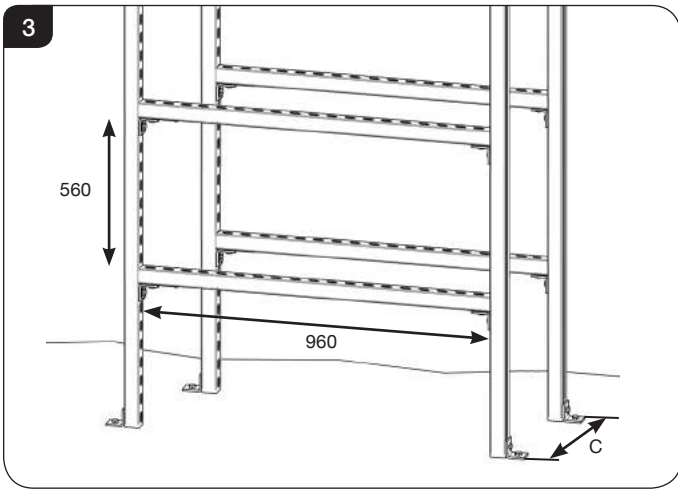

! Dimension C (to the outside of the frame work) must equal the appliance depth (400mm) minus the thickness of the non combustible board chosen, see Diagram 4.

There is an adjustable flange which can be moved up to 5mm to allow refinement of the installation.

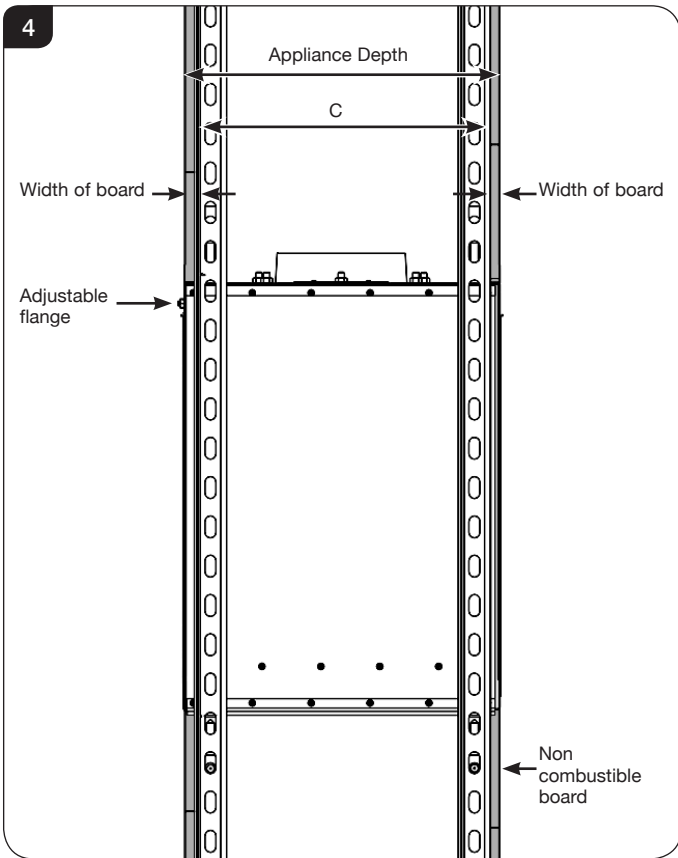

2.7 Support the outer box using metal framework (I.e Unistrut) construction secured to a non combustible floor, see Diagram 5.

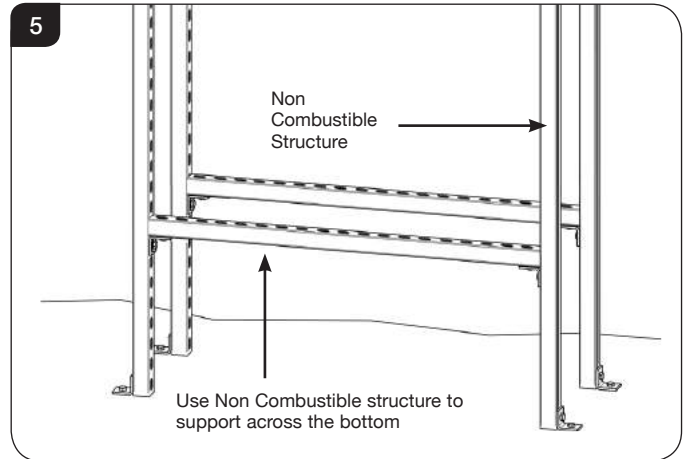

2.8 Mount the outer box onto the frame and finish the studwork support, see Diagram 6.
Note: Do not secure to the studwork at this point.

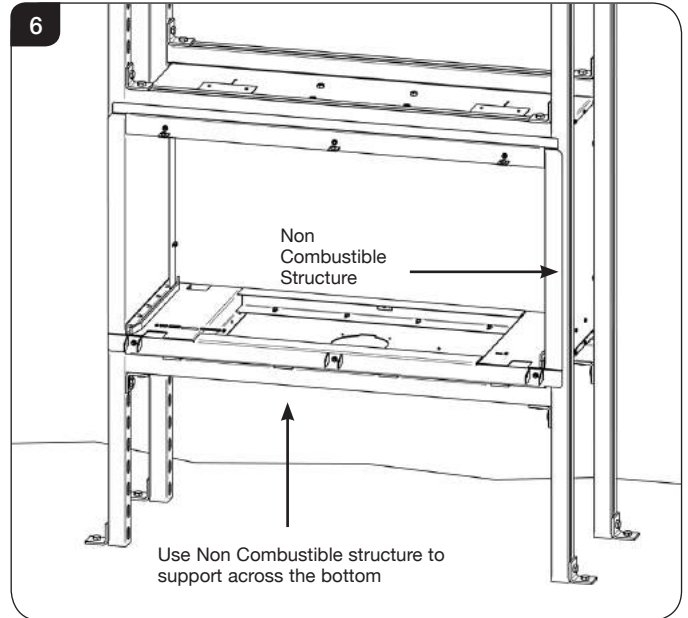

2.9 The bolts can be loosened on the adjustable flange and the frame moved outwards to allow refinement of the installation, See Diagram 7 & 8.
The frame is one complete item.

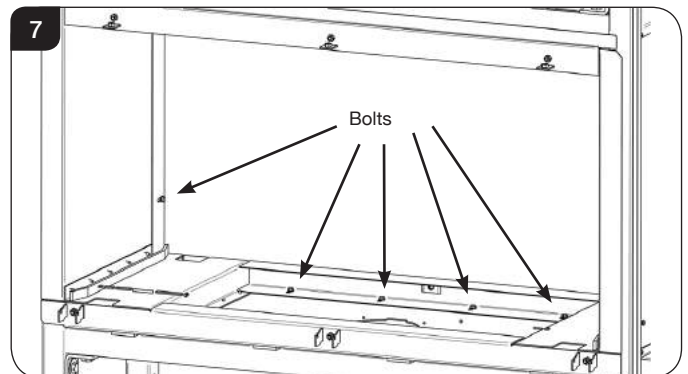

Installation Instructions

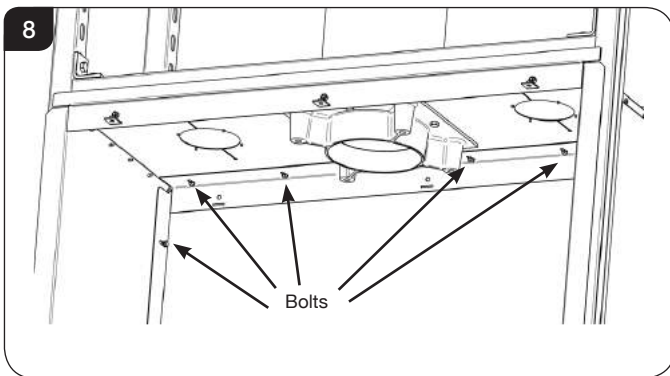

2.10 Secure the box to the frame with 4 self tapping screws, one in each corner, see Diagram 9.

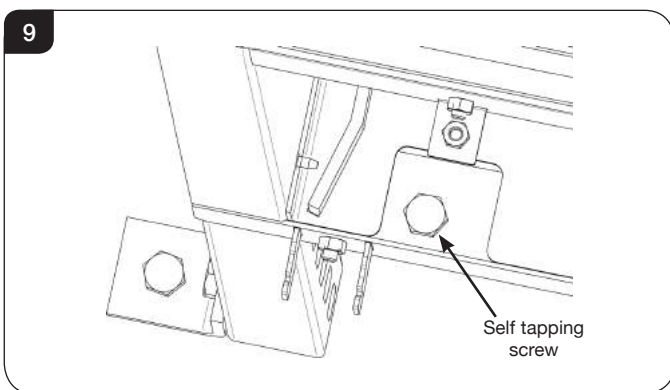

3. Flue Assembly

Twin Wall Flue System

It is recommended that this appliance is used in conjunction with a twin wall flue system. Stovax have designed their own Professional XQ range and details of this product are available from your Stovax retailer.

Alternatively it can be used with a flexible liner in accordance with manufacturers instructions.

NOTE: The flue liner must be supported in accordance with the manufacturers instructions, there should be no weight on the Outer Box.

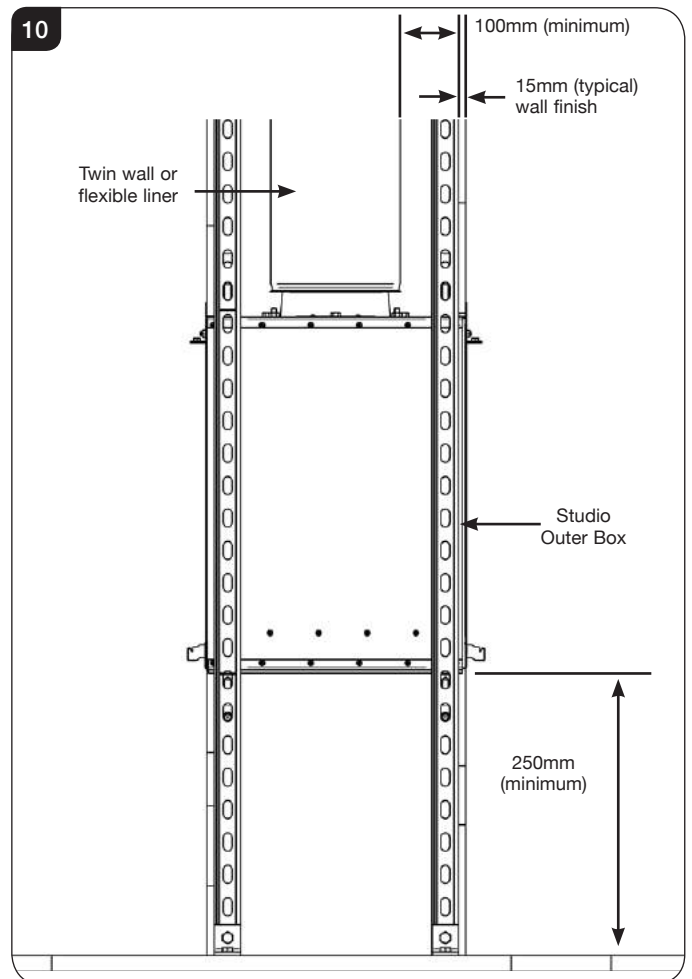

3.1 Ensure the clearances to combustibles are maintained, see Installation Section 2, Diagram 2.

i External Air Kit

If an External Air kit is to be used with the Duplex it is best to install it at this point. To install the Dedicated Sealed External Air Kit see separate installation instructions (Stovax Code: PM959).

The Stovax Duplex has a dedicated air system that allows the supply of air directly to the appliance without the need for an air brick to be added to the room where it is installed for additional ventilation.

However due to conditions in the current edition of Building Regulations, a registered HETAS installer cannot sign off such an installation. If you wish to avoid fitting an air brick by using the Stovax Dedicated Outdoor Air System, it will be necessary to contact your local Building Control Officer who will be able to sign off the installation provided it meets the requirements of the manufacturer.

3.2 Fit non-combustible board to both sides of the studwork and behind the flange to a height of at least 900mm above the opening and 400mm to the sides.

Use the adjustable flange to ensure that there is no gap between the outer box and the boarding.

3.3 Apply a heat resistant plaster finish to at least 600mm above and 300mm to both sides of the studwork frame.

Installation Instructions

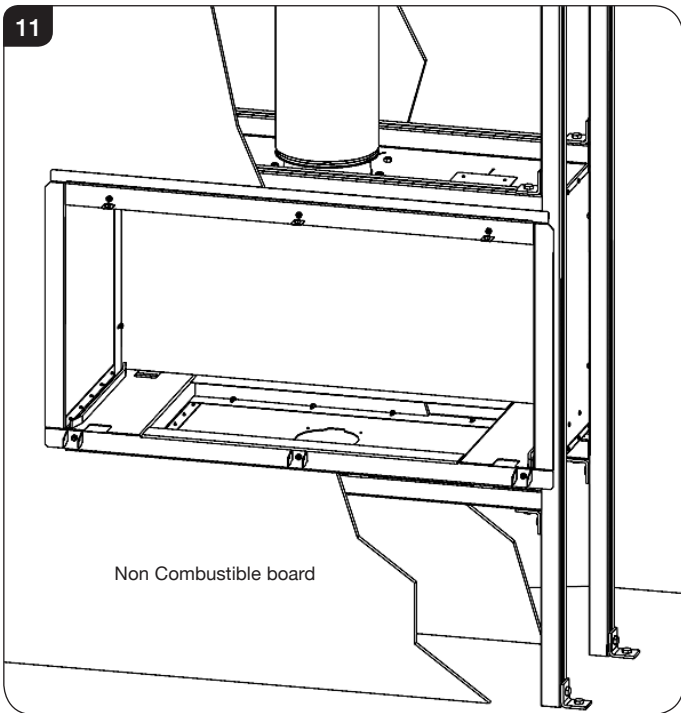

4. Inserting the Inner Box

4.1 Fit the inner box so that the edge is flush with the flange of the outer box.

The inner box can only be fitted through the opening opposite the side with the adjustable flange and bolts, see Diagram 12.

This will require at least 2 people.

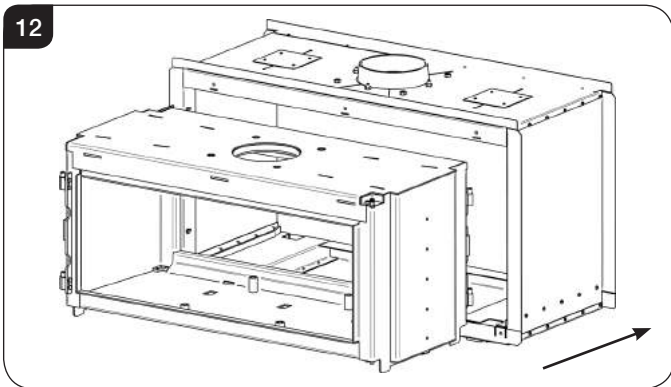

4.2 Apply fire cement in to the faces shown prior to fitting the inner collar, see Diagram 13.

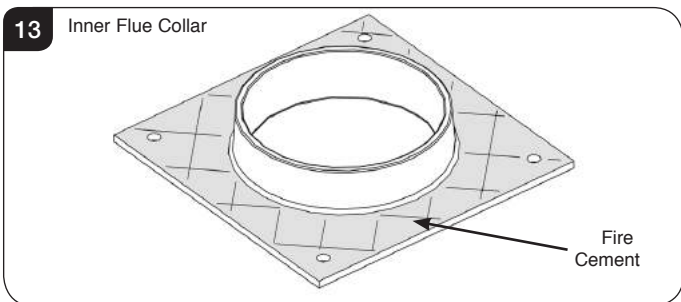

4.3 Fit the inner flue collar using the 4 x bolts. This should be done by hand and the bolts should be finger tight only.

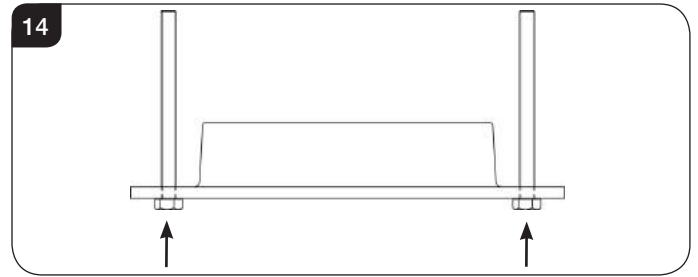

4.4 Ensure that the front of the inner box is flush to the outer box, see Diagram 15. This may require several adjustments to find the correct position. Fully tighten the 4 x bolts. Do not over tighten.

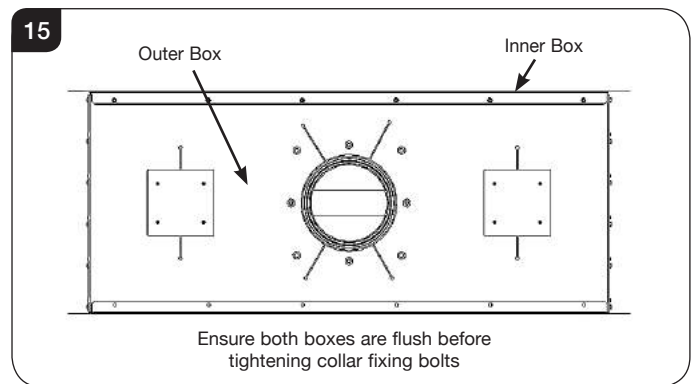

4.5 Replace the internal components (baffles, bricks, doors etc), see relevant Pre-Installation sections.

To finish this installation, connect:

- The Outside Air Kit
- Convection Ducting Kit (optional)

After commissioning:
Finish the sides of the chimney breast, see Diagram 16 .

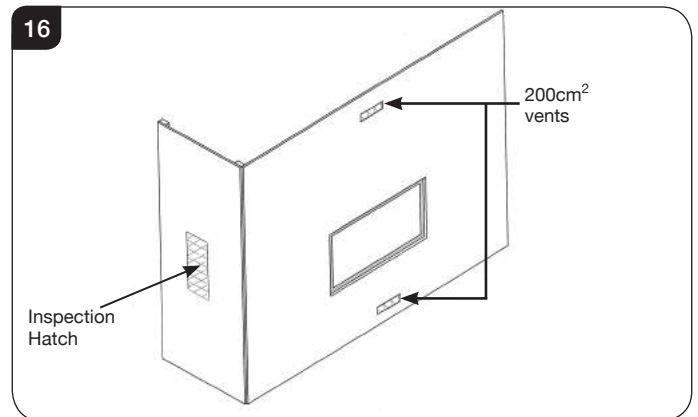

Installation Instructions

5. Frameless Edge Installation Kit

There is an optional Studio Edge Installation Kit designed to create a minimalist frameless finish making the appliance a focal point of any room:

Studio Duplex 2 Code No. RVS-2FEKW,

The Edge installation kit is provided in Matt Black. If necessary the kit can be finished to match the front face decor.

- 5.1 To fit the frame:
Position on appliance and secure as detailed in the frame fitting instructions (PM378).

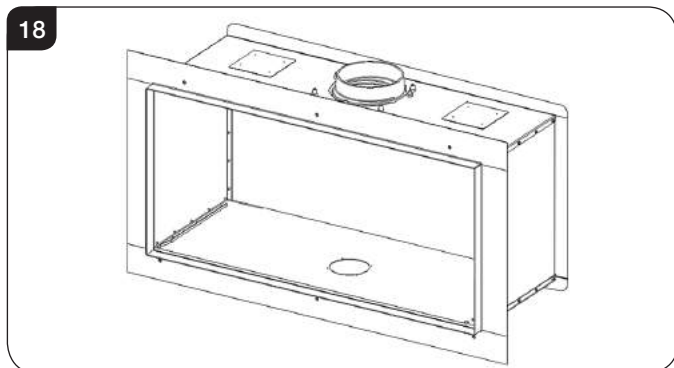
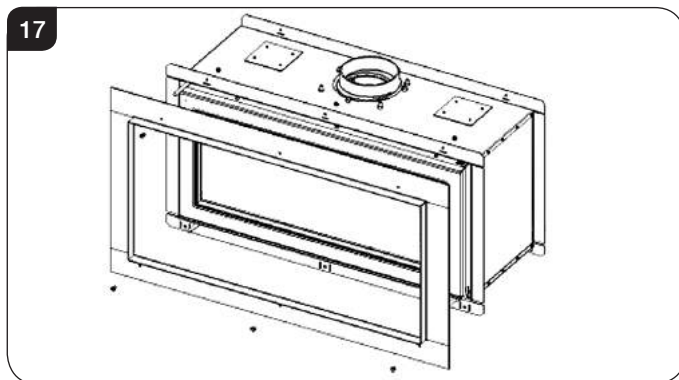

- 5.2 Build the studwork chimney breast to support the cassette, See Diagram 19.
Ensure all clearances to combustible material are maintained, See Pre-Installation Section 4.
To prevent cracking ensure no joints above the appliance.

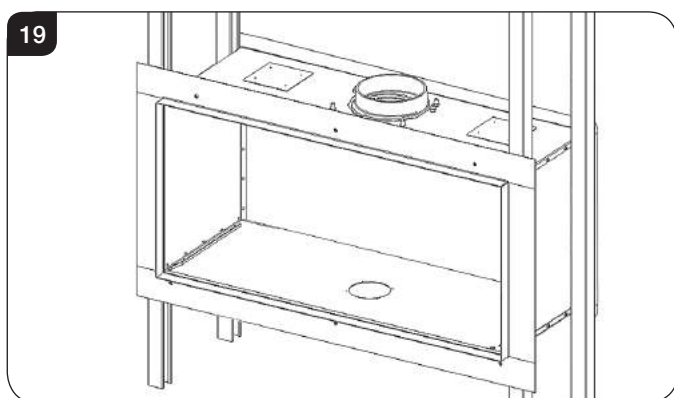

- 5.3 Fit non combustible board to studwork/frame/masonry and leave enough room for the final skim of heat resistant plaster.

The depth of the Edge flange will vary depending on the model of Studio. To ensure a flush finish the non-combustible board and the final plaster skim must add up to Dimension A, See Diagram 20 and the table below.

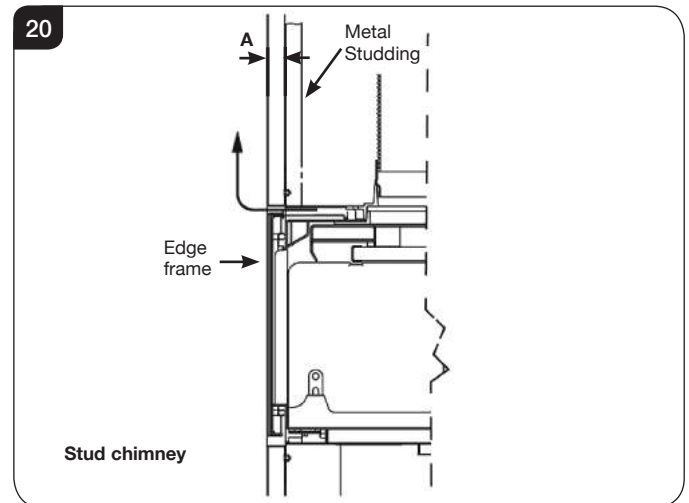

Model	A (mm)
Riva Studio Duplex	34

Standard plasterboard is not suitable

This should extend a minimum of 600mm to the sides and above the appliance.

Apply a heat resistant plaster finish to **at least 900mm above and to the sides of the chimney breast**, making sure it is not too thin or it will crack, see Diagram 21.

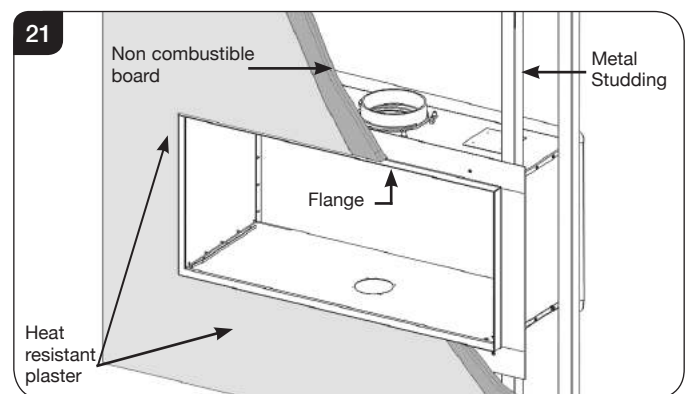

- 5.4 Allow for the connection of the following:
- Electrical services (for fan installation) using the opening in the side of the chimney breast for access.
 - The Outside Air Kit (optional)
 - Convection Ducting Kit (optional)
 - The flue system (see Installation, Section 3 Flue Assembly)

To finish this installation re-install the inner box.

Installation Instructions

5.5 After commissioning, finish the sides of the chimney breast, see Diagram 22.

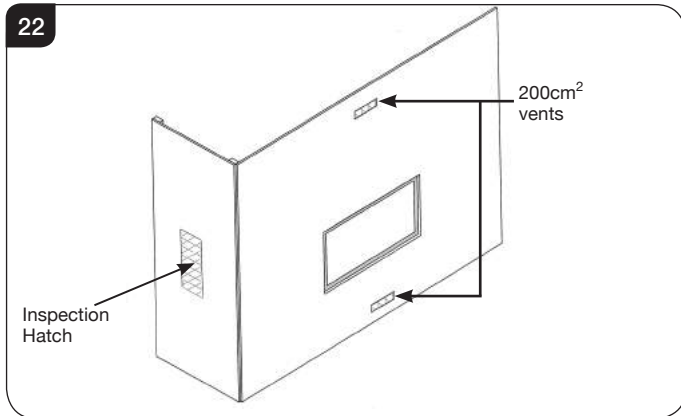

6. 'Cool Wall' Installation Kit

The Cool Wall kit gives the appliance a stylish frameless Edge finish but allows the convected heat of the fire to be channelled into the chimney cavity and vented at the top: Studio Duplex 2 Code No. RVS-2FCWKW.

The Cool Wall installation kit is provided unfinished. This allows the kit to be finished to match the front face decor.

6.1 To fit the frame:
Position on appliance and secure as detailed in the frame fitting instructions (PM378).
There is a gap at the top for convected heat to pass behind the finished wall.

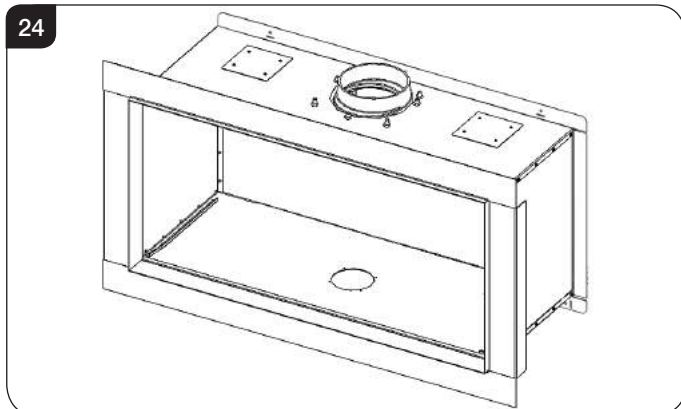
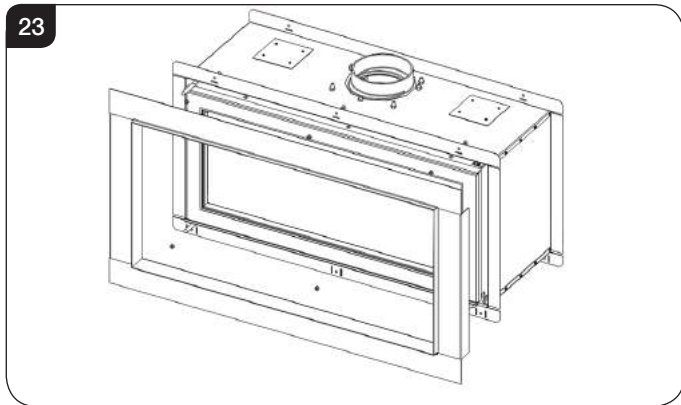

6.2 The frame determines the width of the two vertical studwork supports. The kit has been designed so that non-combustible board can be taken right up to the edge of the frame, see Diagram 25.

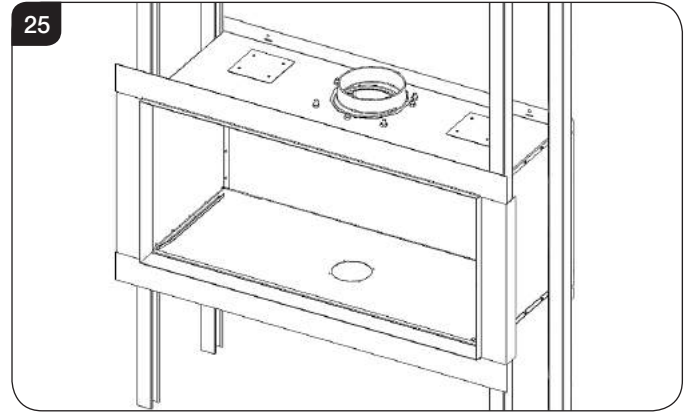

6.3 When constructing the studwork chimney breast the depth of the Cool Wall flange will vary depending on the model of Studio.
To ensure a flush finish the non-combustible board and the final plaster skim must add up to Dimension A, see Diagrams 26 and the table below.
Dimension B is the depth of the convection channel. Do not place combustible material in this area.

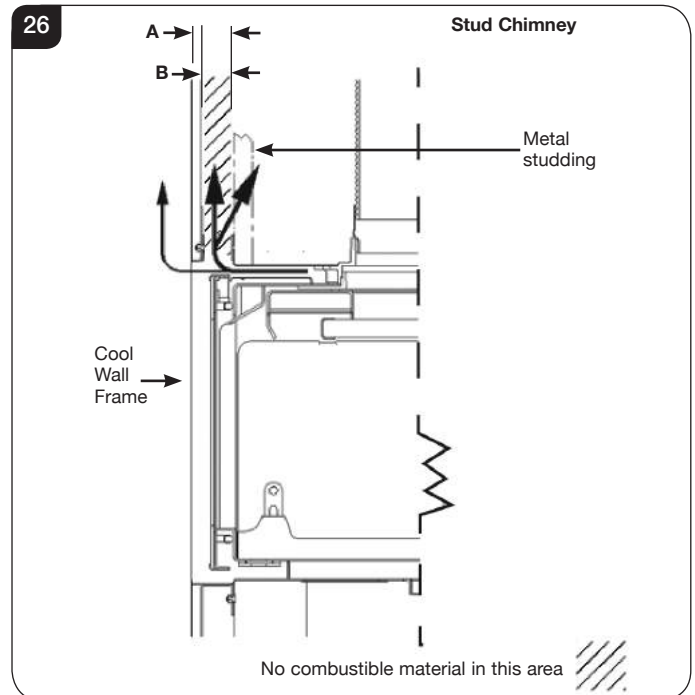

Model	A (mm)	B (mm)
Riva Studio Duplex	59	43

6.4 Fit non-combustible board to the studwork above the fire. Leave enough room for a final skim of plaster.

Standard plasterboard is not suitable
This should extend to the whole height of the wall and a minimum of 600mm to the sides of the appliance. To prevent cracking ensure there are no joints above the appliance. No combustible materials are to be placed in the convection aperture, see Diagram 27.

Installation Instructions

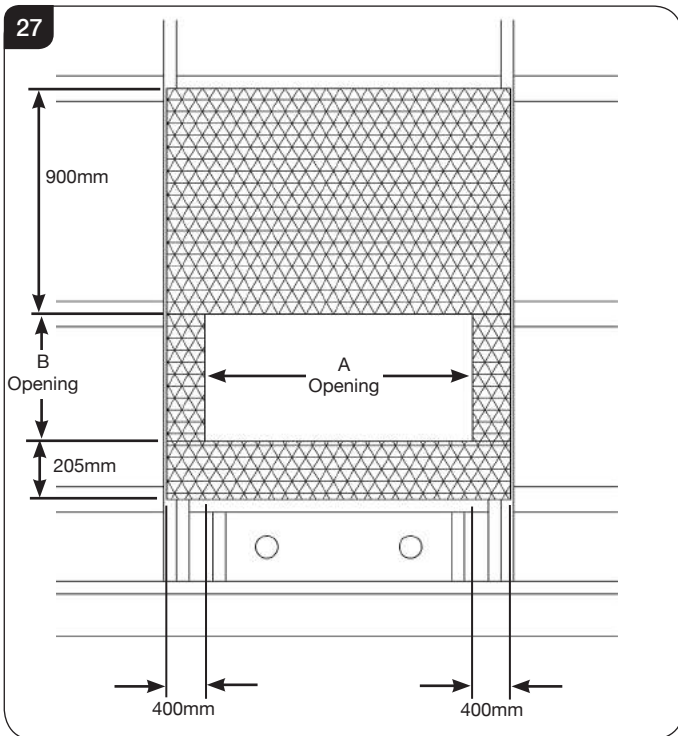

Model	A	B
Riva Studio Duplex	950	452

Do not pack the void around or above the appliance with insulation materials such as mineral wool or vermiculite.

An access hatch must be left in the side of the chimney breast for future servicing and inspection of the flue and appliance.

6.5 Apply a heat resistant plaster finish to **at least 900mm above and 400mm to the sides of the chimney breast**, making sure it is not too thin or it will crack, see Diagram 28.

The top of the chimney breast must have a minimum 200cm² vent.

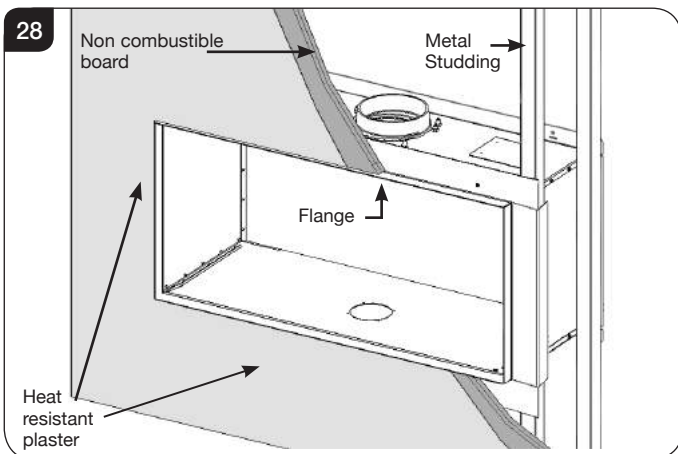

- 6.6 Fit plasterboard to the remaining chimney breast front.
- 6.7 Allow for the connection of the following:
 - Electrical services (for fan installation) using the opening in the side of the chimney breast for access.
 - The Outside Air Kit (optional)
 - Convection Ducting Kit (optional)
 - The flue system (see Installation, Section 3 Flue Assembly)
- 6.8 Connect the flue system and electrical services if fan is to be fitted using the opening in the side of the chimney breast for access.
- 6.9 Apply a heat resistant plaster finish to **at least 900mm above and to the sides of the chimney breast**

To finish this installation re-install the inner box.
- 6.10 After commissioning, finish the sides of the chimney breast, see Diagram 29.

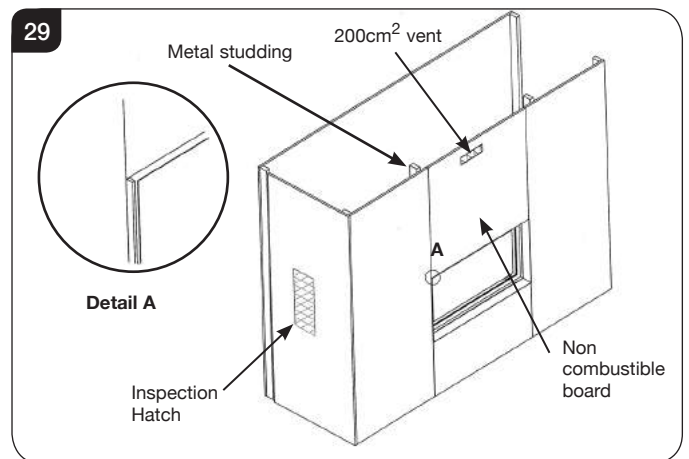

Installation Instructions

7. Fitting of Internal Components

Once the inner box has been installed the internal components can be fitted.

- 7.1 The Firebricks and Baffle bricks are supplied in a box for safe transportation. It is advisable to carefully remove all of the bricks from the container in order to correctly identify the various types.
- 7.2 The baffle components must be fitted before the firebricks.

Baffle

The appliance is fitted with baffles in the top of the firebox to maintain efficient combustion.

- 7.3 Fit the baffle bricks on each side ensuring that they are in the correct orientation. The cut outs on the side baffle bricks must be at the top, see Diagram 30.
- 7.4 Place the two outer bricks in position and use them to support the centre, see Diagram 30.

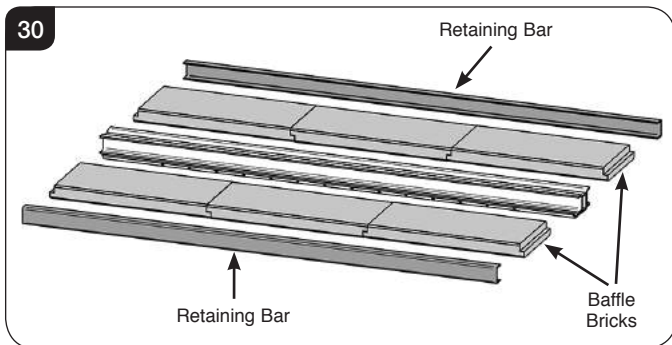

- 7.5 Push all the bricks together to close any gaps and secure with the retaining bars.
- 7.6 Repeat for the other side.
- 7.7 Now fit the firebricks in the correct order, see 7.10.
- 7.8 When finished pull the baffle bricks down so the bars sit flush on the side firebricks.

The baffle system is designed to give safe and efficient operation of the appliance.
Replace damaged baffles immediately.

Do not modify the baffle system.
Do not operate with the baffle system removed.

Firebricks

- 7.9 Once the Baffle has been fitted it is possible to install the Firebricks.
- 7.10 The side bricks have part of the Log bar supports attached. These must be fitted and removed at the same time as the bricks.
- 7.11 Install in the following order, see Diagram 31.
Take care when handling and do not force into position.

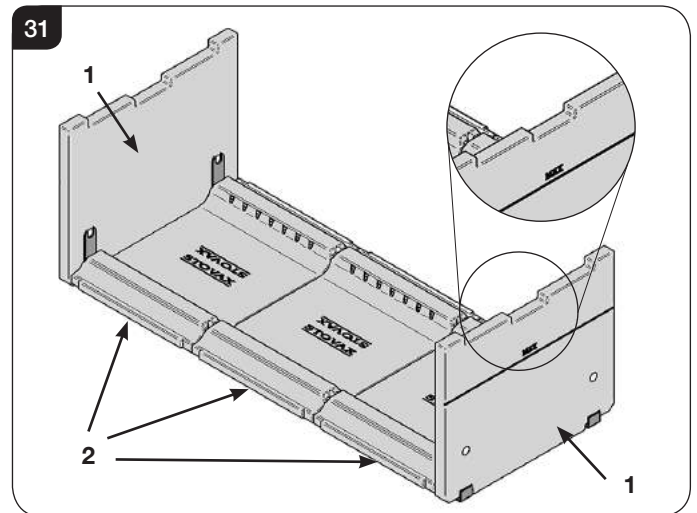

- 7.12 To do this:
 - Fit the side bricks (1) with the Log Guard Supports in place. The Log Bar Support holes can be used as a finger hold.
 - Place the base bricks in the firebox (2). Fit the left and right hand base bricks, then the middle.
- 7.13 Removal is the reverse of this procedure.

Allow the appliance to cool fully before removing baffle system.

Do not modify firebricks.
Do not operate with firebricks removed.

Installation Instructions

Log Guard

7.14 Ensure that the side supports have been fitted at the same time as the side Firebricks, see Diagram 32.

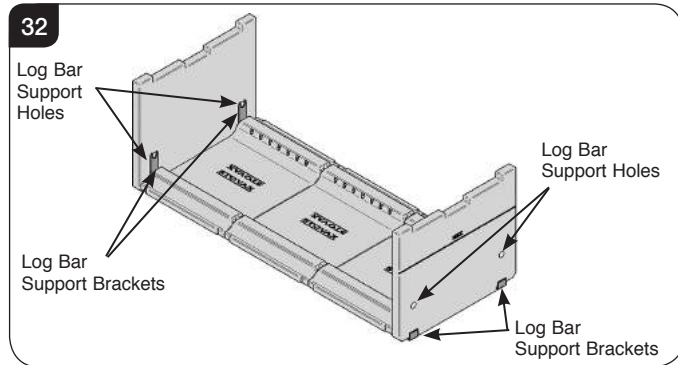

To fit the Log guards:

- Insert the Log Guard through the front of the appliance at an angle and rotate.
- With one end raised place the other end into one of the holes in the side bricks.
- Lower the Log Guard and insert the supports into the gaps between the base bricks and into the retaining brackets, see Diagram 33.

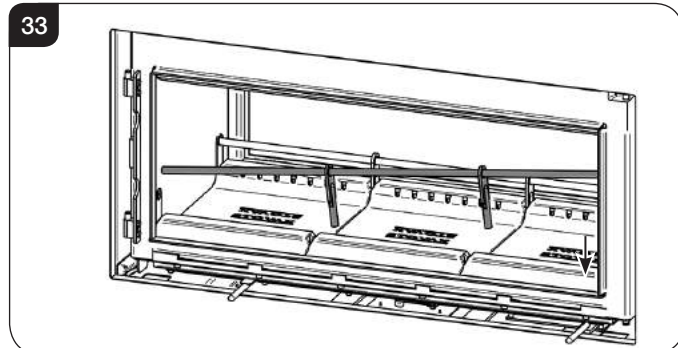

- Slide the Log Guard across so both ends locate evenly in the holes in the side bricks, see Diagram 34.

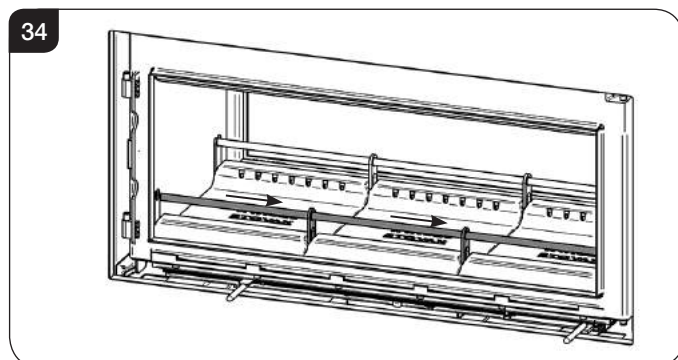

7.15 Repeat on the other side.

Do not use appliance without the log guard in position.

8. CO Alarms

All open flued appliances can be affected by temporary atmospheric conditions which may allow fumes to enter the house. **Building regulations require that whenever a new or replacement fixed solid fuel or wood/biomass appliance is installed in a dwelling a carbon monoxide alarm must be fitted in the same room as the appliance.** Further guidance on the installation of the carbon monoxide alarm is available in the latest edition of BS EN50292 and from the alarm manufacturer's instructions.

HETAS recommend the unit is permanently fixed in accordance with the manufacturer's installation instructions or with the guidance contained in Approved Document J where no other information is available.

Provision of an alarm must not be considered a substitute for either installing the appliance correctly or ensuring regular servicing and maintenance of the appliance and chimney system.

Commissioning

Commissioning

1.1 To commission:

- Replace the internal components
- Check the door alignment and catch operation and adjust if required (see Maintenance and Servicing Sections 4 & 5).
- Check the soundness of door seals, castings and joints.
- Check the operation of the air controls.

1.2 Now carry out a final smoke draw test:

- Warm the flue with a blowlamp, or similar, for about 10 minutes.
- Place a smoke pellet on the centre of the grate, with the air controls open.
- Close the door. Smoke should now be drawn up the flue and be seen to exit from the flue terminal.
- Complete test with all doors and windows closed in the room where the appliance is fitted.
- If there are any extractor fans in adjacent rooms the test must be repeated with the fans running on maximum and with interconnecting doors open.
- Check the effect of ceiling fans during the test.

If the test fails, re-check the suitability of the flue system and ventilation. An inadequate air supply to the room is potentially dangerous.

- Light the appliance and slowly increase the temperature.
- Ensure no combustion products enter the room.
- Open the main fire door when the appliance reaches operating temperature and carry out a spillage test with a smoke match or pellet around the door opening.

1.3 If excessive spillage occurs allow the appliance to cool and re-check the flue system and ventilation.

1.4 Finally:

- Explain to the user the safe operation of the appliance, use of the controls and the importance of only using suitable fuels.
- Ensure that a CO alarm has been fitted and make the user aware of its operation and importance, referring them to the Warning section on page 5 of the User Instructions.
- Explain the cleaning and routine maintenance requirements.
- Explain the requirement to use a suitable fireguard when children, elderly or infirm persons are near the appliance.
- Record retailer/supplier and installer details in Appliance Commissioning Checklist (page 3, Instructions for Use).
- Record serial number in Appliance Commissioning Checklist (page 3, Instructions for Use).

This number is required when ordering spare parts and making warranty claims.

- Give this instruction manual to the customer.

Certificate Of Compliance

Upon completing the installation, the form below must be filled in by your installer to comply with the requirements of HETAS and the building regulations. The installer must give these details, including their HETAS registration number, for the purposes of any insurance details that may change as a result of the appliance being installed.

HETAS LTD - CERTIFICATE OF COMPLIANCE

PLEASE TICK APPROPRIATE BOXES OR ENTER DETAILS IN BOXES BELOW



Record ID (HETAS Use Only)	<input type="text"/>	(*indicates that this data must be given)
Customer Name	*	
Installation Address	*	
Installation Address		
Installation Address		
Installation Address		
Town	*	
Postcode	*	Work Completion Date *
Local Authority Name (*Must be given if no postcode available)		
Installing Company Name	*	Company's HETAS Reg. No. *
Installing Engineer's Name	*	Engineer's HETAS Reg. No. *

Description of Work

Location:
 Lounge Dining Room Kitchen Utility Room Bedroom Other, Specify

Appliance: Dry Open Fire Open Fire with Boiler Dry Cooker Cooker with Boiler
 Dry Roomheater/Stove Roomheater/Stove with Boiler Independent Boiler
 Make Model Heat Output kW

System: New Heating and Hot Water System Updated Existing Heating and Hot Water System Dry System Only

If Wet System: Is the Hot Water System Unvented? Y N

Chimney: New Insulated Factory Made Chimney System Installed

Relining of existing chimney: Twin Wall Flexible Liner (for Class 1 Appliance) Cast In-situ Liner
 Rigid Sectional Liner Metal Rigid Sectional Liner Other

Hearth: New Hearth/Surround fitted Existing Hearth Surround Updated

Additional Information

Connecting fluepipe: Diameter mm Socket joints upward and gas tight

Provision for sweeping chimney/fluepipe: Yes No Chimney Data Plate Location

Air supply: Has a permanently open air vent been fitted: Yes No
 Is vent opening at least 50% of cross sectional area of throat/flue or State total free area of air vent mm²

Confirm an approved Carbon Monoxide alarm has been fitted

Testing & Commissioning to Approved J Appendix E

Confirm you have commissioned and tested the appliance & associated work for safe and efficient operation

Declaration of completion As the competent person responsible for the work described above, I confirm that the appliance and associated work has been installed in accordance with the HETAS rules of registration, and that the work complies with Regulations 4 and 7 of the Building Regulations, and Approved Documents J, G & L as applicable.

Signed: _____ Print name: _____ Date: _____

COPIES OF THIS COMPLETED CERTIFICATE MUST BE (WHITE COPY) SENT TO HETAS LTD AT THE ADDRESS GIVEN BELOW (PINK COPY) GIVEN TO THE CUSTOMER FOR RETENTION (YELLOW COPY) RETAINED BY THE INSTALLING COMPANY

**THIS CERTIFICATE SHOULD BE RETAINED BY THE PROPERTY OWNER
WHO MAY BE REQUIRED TO PRODUCE IT IN ANY FUTURE SALE OF THE PROPERTY.**

Maintenance & Servicing

1. Annual Service

- 1.1 Before the start of the heating season strip, inspect and clean the appliance as detailed:
- Allow appliance to cool.
 - Remove all internal parts: baffle, log guard and firebricks. Take care handling firebricks as they can become fragile after a period of use.
 - Sweep the appliance at this point if necessary.
 - Vacuum clean any remaining ash and debris from the inside of the appliance. Stovax offer a filter/collection attachment for vacuum cleaners to protect them from fire ash: Ash Clean (Stovax Part No. 2091).
 - Check the parts for any damage. Replace any damaged parts using genuine Stovax replacements parts.
 - Check and clean the firebricks with a soft brush. Some surface damage will occur during use. The life of the bricks will depend on the type of fuels burnt and the level of use. **Replace damaged bricks as soon as possible.**
 - Re-fit cleaned internal parts.
 - On appliances with printed glass do not use cleaning agents that have a high alkaline or acidic content, for example Stovax Gel Cleaner, these are aggressive cleaning agents designed to be used with heavily stained clear glass. On printed glass surfaces, use Stovax Glass Cleaner (Stovax No.4103) which is better formulated for this application.**
- Do not use abrasive cleaners to remove tar or soot deposits from the glass.**
- Fit new door rope seal (see Maintenance and Servicing, Section 6).
 - Lightly oil the door catch mechanism and hinge pins. Avoid getting oil onto the door seals and glass.
 - To refresh painted finishes a touch up spray is available. Contact your Stovax retailer quoting the serial number found on the appliance date badge.

- 1.2 Use genuine Stovax replacement parts to keep the appliance in safe, efficient working order. This is a list of the maintenance products that may need be required:

Task	Product name
Preventing build-up of creosote in flue	Protector (15 sachets)
	Protector (1kg tub)
Sealing flue pipe joints	Fire Cement (500g tub)
	Fire Cement (600g cartridge)
Re-painting	Touch Up Aerosol (150ml aerosol)
Protecting your hands	Heat resistant leather gloves
Thermic seal glue	(50ml bottle)
Cleaning Glass	Stovax Glass Cleaner
	Stovax Gel Cleaner
Ash Clean	Vacuum Cleaner Attachment

These products, available online at www.stovax.com or from your local Stovax dealer, along with regular maintenance and use of correct fuels, will keep the appliance in the best possible condition.

- 1.3 For more information about the Stovax Group products please visit our web site at www.stovax.com
- 1.4 Burn at a low temperature for the first day of use after any maintenance. This allows the seals, fixing glues and paint to fully cure.
- 1.5 During this time the appliance may give off some unpleasant odours. Keep the room well ventilated to avoid a build-up of fumes.
- 1.6 Your Stovax dealer can carry out service and maintenance.

2. Removal of Internal Parts

- 2.1 To service and maintain the good working condition of your appliance it will be necessary to remove several internal parts. Consult the installation section for the following:
- Door Assembly** - Pre-Installation Section 2, page 15.
 - Separating the Inner and Outer Box** - Pre-Installation Section 4, page 15.
- 2.2 Reverse the method of installation to remove the **Baffle Bricks, Firebricks** and the **Log Guard** see Installation Section 7.

Maintenance & Servicing

3. Fitting a new Door Seal - Both Sides

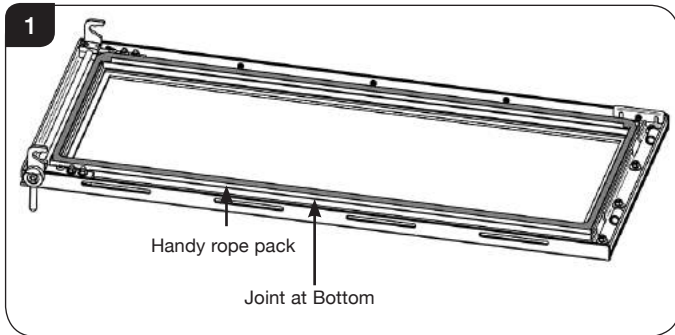

- 3.1 To maintain the safe use of your appliance you need to replace damaged or worn door sealing rope. To complete this operation remove the door see Section 2 Removal of the Door in the pre-Installation section.
- 3.2 Remove the old rope and scrape old glue from the locating groove. Clean the locating groove with a clean dry cloth to remove all old dust and debris.
- 3.3 Squeeze a generous bead of fresh Stovax Thermic Seal glue into the rope locating groove.

Press the new Stovax rope into the locating groove, placing the joint in the middle of the top edge of the door using tape supplied for the ends.
- 3.4 Refit the door and close the door to apply pressure to the new rope.

Leave the appliance closed for at least 12 hours before lighting the appliance and using at a low output for approximately one day.
- 3.5 Using the appliance with a damaged door seal can cause dangerous fumes to enter the room, or the appliance to over fire, resulting in damage.

4. Adjusting Door Hinges - Both Sides

- 4.1 To maintain the safe use of your appliance, you may need to adjust the door hinges to ensure the safe, correct closing of the door. The door must be horizontal/level with the top of the inner box and the door catch engages correctly.
- 4.2 Adjustment is possible in 2 places:
Door Hinge Assembly
Hinge Blocks on Inner Box
- 4.3 Open the door to give access to these 2 positions.

Door Hinge Assembly

- 4.4 Use a 10mm socket to slightly loosen the fixing nuts on the Door Hinge Assembly, see Diagram 2.

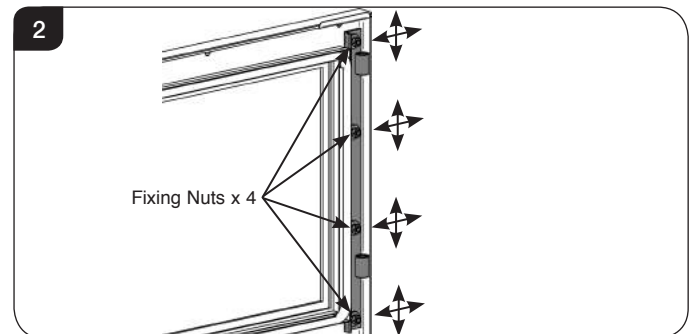

- 4.5 Loosening the Door Hinge Assembly allows for fine vertical and horizontal adjustment of the door position. This may require a trial and error approach to find the correct position. Ensure the door is horizontal before tightening the fixing nuts.

Hinge Blocks on Inner Box

- 4.6 Using a 10mm A/F spanner slightly loosen the fixing nuts inside the stove as shown in Diagram 3. This will give vertical and horizontal adjustment which may need a trial and error approach to find the correct position. The door must be horizontally level.

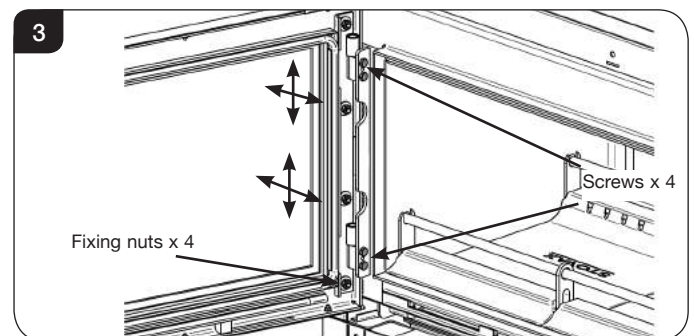

5. Adjusting the Door Catch - Both Sides

- 5.1 To maintain the safe use of your appliance you may need to adjust the door catch to ensure the safe, correct closing of the door. If the door hinges have been adjusted the door catch may need adjustment.
- 5.2 The catches are located at the top and the bottom of the right side of the door.

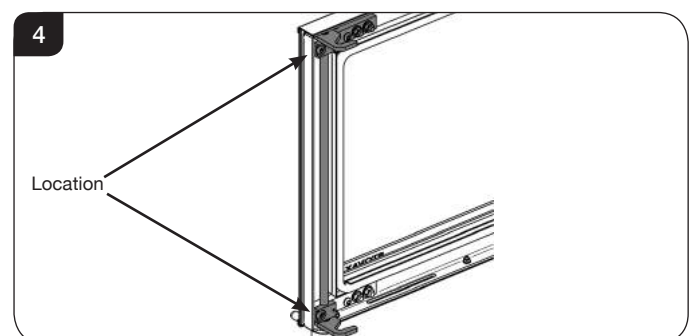

Maintenance & Servicing

- 5.3 The top and bottom catches will need to be adjusted separately and in the same manner. The catch block can move in two directions, see Diagram 5, 6 & 7.

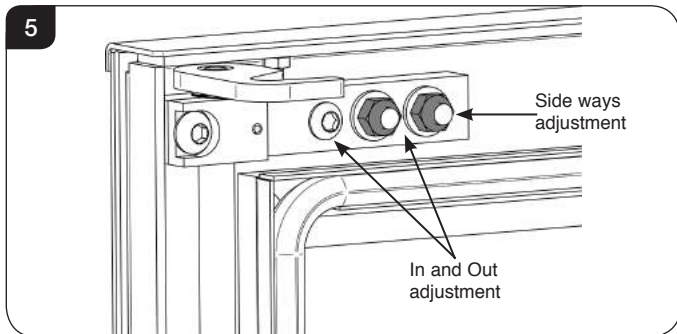

Sideways Adjustment

Using a 10mm A/F Spanner loosen the 2 nuts that hold the catch block to the door.

Do not remove the nuts completely.

This will allow some movement left or right to suit.

Tighten the nuts and recheck the catch operation.

In and Out Adjustment

Loosening or tightening the M6 screw and the nuts on the catch block will cause the catch to move in or out from the door and allow the hook to gain better purchase on the door rollers.

Do not remove screw or nuts completely.

- 5.4 **To move Door Catch in:**

Loosen Nuts 1 & 2.

Wind screw **IN** until the Door Catch is in desired position.

Tighten Nuts 1 & 2 down to Catch Block.

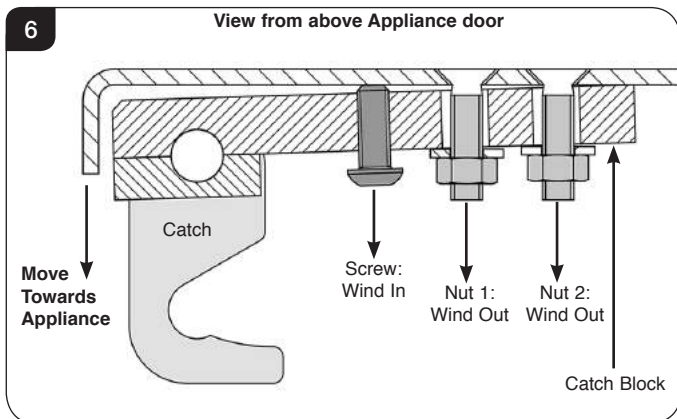

- 5.5 **To move Door Catch out:**

Loosen Nuts 1 & 2.

Wind screw **OUT** until the Door Catch is in desired position.

Tighten Nuts 1 & 2 down to Catch Block.

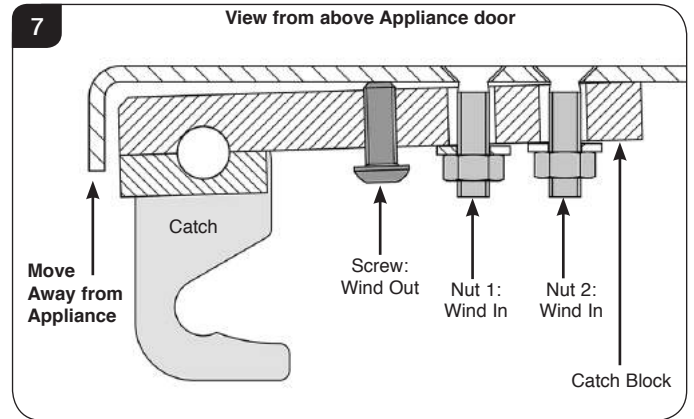

Do a Paper Test

To do a paper test shut a piece of paper in the door at the edges to test how well the rope seal stops the air from entering the appliance. If the paper can be pulled out easily then the seal is not sufficient and the rope must be replaced. Repeat this around all the edges of the appliance.

Technical Appendix - Technical Appendix

Legal Requirements

Before installation and/or use of this appliance please read these instructions carefully to ensure that all requirements are fully understood.

The appliance must be fitted by a registered installer*, or approved by your local building control officer.

It is very important to understand the requirements of the national Building Regulations† and standards‡, along with any local regulations and working practices that may apply. Should any conflict occur between these instructions and these regulations then the regulations must apply.

Your local Building Control Office can advise regarding the requirements of the regulations.

i † England and Wales – Document J / Scotland - Part F/Document J (Republic of Ireland only)
‡ the latest edition of BS 8303, BS EN 15287, BS 7566

*Registered on the Competent Persons Scheme (GB only) see page 34/ INFO (Republic of Ireland).

Works must be carried out with care to meet the requirements of Health and Safety† and comply with the Health and Safety rules**, and any new regulations introduced during the lifetime of these instructions. Particular attention should be drawn to:

- **Handling:** The appliance is heavy. Adequate facilities must be available for loading, unloading and on site handling.
- **Fire Cement:** Some fire cement is caustic and must not come into contact with the skin. Protective gloves must be worn. Wash hands thoroughly with plenty of water after contact with skin.
- **Asbestos:** This appliance contains no asbestos. If there is the possibility of disturbing any asbestos in the course of installation seek specialist guidance and use appropriate equipment.
- **Metal Parts:** Take care when installing or servicing the stove to avoid personal injury.

A faulty installation can cause danger to the inhabitants and structure of the building.

For users of this appliance:

Your building insurance company may require you to inform them that a new heating appliance has been installed on your property. Check that your cover is still valid after installing the appliance.

1. Flue Outlet Positions

These positions are defined by Document J of the Building Regulations.

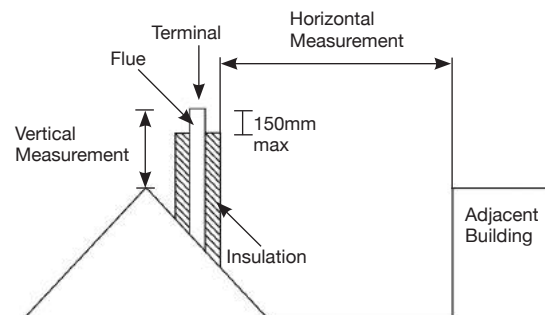
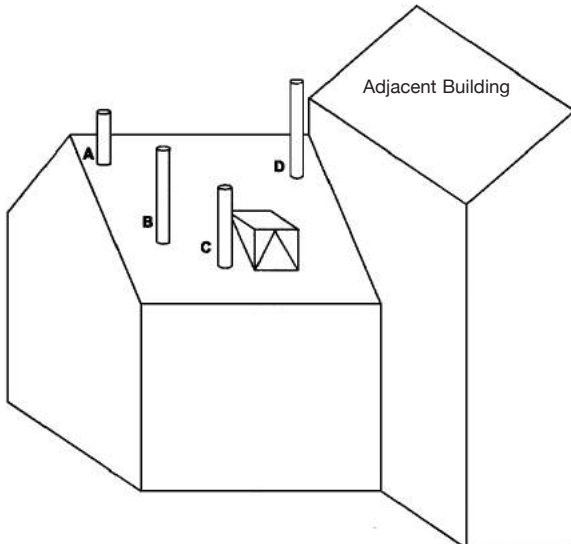

The datum for vertical measurement is the point of discharge of the flue from either the point of discharge of the flue or 150mm above insulation, whichever is the lower.

IMPORTANT: Seek specialist advice if installing in a dwelling with a thatched roof

Point where the flue passes through weather surface (Notes 1 & 2)		Clearances to flue outlet
A	At or within 600mm of the ridge	At least 600mm above ridge
B	Elsewhere on roof (whether pitched or flat)	At least 2300mm horizontally from the nearest point on the weather surface and: a) at least 1000mm above highest point of intersection of the chimney with and the weather surface; or b) at least as high as the ridge
C	Below (on a pitched roof) or within 2300mm horizontally to openable rooflight, dormer window, or other opening (Note 3)	At least 1000mm above the top of opening
D	Within 2300mm of an adjoining or adjacent building, whether or not beyond the boundary (Note 3)	At least 600mm above any part of the adjacent of building within 2300mm

1) The weather surface is the building external surface, such as it's roof tiles or external walls.
2) A flat roof has a pitch less than 10°.
3) The clearance given for A or B, as appropriate, will also apply.
4) A vertical flue fixed to an outside wall should be treated as equivalent to an inside flue emerging at the nearest edge of the roof.

Technical Appendix - Flues

2. Flue or Chimney

- 2.1 The flue or chimney system must be in good condition. It must be inspected by a competent person and passed for use with the appliance before installation.

Products of combustion entering the room can cause serious health risks.

- 2.2 The following must be checked:

— The construction of the masonry chimneys, flue block chimneys and connecting flue pipe system must meet the requirements of the Building Regulations†.

— A flexible flue liner system can be used if certified for use with solid fuel systems and installation complies with manufacturer's instructions and Building Regulations. The flue liner must be replaced when an appliance is replaced, unless proven to be recently installed and in good condition.

— If it is necessary to fit a register plate it must conform to the Building Regulations†.

— The minimum height of the flue or chimney must be 4.5m from the hearth to the top of the flue, with no horizontal sections and a maximum of 4 bends. Bends must have angles of less than 45 degrees from the vertical.

— There should be at least 600mm of vertical flue pipe above the appliance before any bends are introduced.

— Ensure the connecting flue pipe is kept a suitable distance from any combustible material and does not form part of the supporting structure of the building.

— The installer must ensure the flue pipe diameter is not less than the diameter of the outlet of the appliance and does not narrow to less than the size of the outlet at any point in the system.

— Make provision to remove the appliance without the need to dismantle the chimney.

— Any existing flue must be confirmed as suitable for the new intended use as defined in the Building Regulations.

— The flue or chimney systems must be inspected and swept to confirm the system is structurally sound and free from obstructions.

— If the chimney is believed to have previously served an open fire it must be swept a second time within a month of regular use after installation to clear any soot falls that may have occurred due to difference in combustion levels.

— The flue exit from the building must comply with local building control rules†.

— Chimney heights and/or separations may need to be increased in particular cases where wind exposure, surrounding tall buildings, high trees or high ground could have adverse effects on flue draught.

— Do not connect or share the flue or chimney system with another heating appliance.

- 2.3 Do not connect to systems containing large voids or spaces over 230mm square.

- 2.4 Suitable access must be provided to enable the collection and removal of debris.

- 2.5 The flue must be swept and inspected when the appliance is installed.

Flue Draught

The flue draught must be checked with all windows and doors closed and any extraction fans in this, or adjoining rooms, running at maximum speed (see Installation Checklist for ventilation requirements).

Twin Wall Flue System

If this appliance is to be used in conjunction with a twin wall flue system then Stovax recommend the use of their Professional XQ range. Details of this product are available from your Stovax retailer.



In the U.K:

***BS EN 15287-1, and the requirements of Building Regulations**

****This should be done by a NACS registered (UK only)/INFO registered (Eire only) chimney sweep, who will issue you with a certificate.**

† Building Regulations Document J

Flue Plate:

Where a hearth, fireplace, flue or chimney is provided or extended (including cases where a flue is provided as part of refurbishment work), information essential to the correct appliance and use of these should be permanently posted in the building, to meet Requirement J4 of the Building Regulations (England and Wales), F3.12 (Scotland).

Additional:

A new factory made system that complies to EN 1856; Part 1 can be used providing installation is to the requirements of:

- i) BS 7566 Parts 1 -4**
- ii) the manufacturer's instructions**
- iii) Building Regulations.**

For a guide containing information on Chimneys and Flues contact:

**The British Flue & Chimney Manufacturers' Association,
FETA
2 Waltham Court
Milley Lane
Hare Hatch
Reading
Berkshire RG10 9TH**

Tel: 0118 9403416

e-mail: info@feta.co.uk

Ventilation - Technical Appendix

3. Ventilation

- 3.1 Many older buildings are sufficiently ventilated by natural leakage of air to provide suitable air supply for an appliance of 5kW output or less.

Modern building techniques have reduced the amount of air that leaks in or out of a house. A modern construction with an air tightness of less than 5m³ per hour per m² requires an air vent for **ALL** solid fuel appliances including those with a rated heat output of less than 5kW.

NOTE: The air leakage of a modern house is tested at the completion of construction and a certificate issued confirming this.

- 3.2 This appliance requires a constant supply of air to maintain proper combustion and effective flue performance.
- 3.3 An inadequate air supply can result in poor combustion and smoke entering the room which is potentially dangerous.
- 3.4 This supply of air can come from either:
- Purpose provided ventilation.
 - Some Stovax appliances can also be fitted with an optional outdoor air kit which allows air to be drawn in from the outside.
- 3.5 The amount of air required must comply with local building regulations and the rules in force.
- 3.6 If spillage is detected during commissioning then there may be insufficient natural ventilation and an additional air supply will be necessary.
- 3.7 Permanent air vents should be non-adjustable and positioned where they are unlikely to become blocked.
- 3.8 If vents open into adjoining rooms or spaces there must be an air vent of at least the same size direct to the outside.
- 3.9 Site the vents where cold draught is unlikely to cause discomfort. This can be avoided by placing vents near ceilings or close to the appliance (See diagram).
- 3.10 Extractor fans or cooker hoods must not be placed in the same room or space as this can cause the appliance to emit fumes into the room.
- 3.11 Increase air supply provisions where a room contains multiple appliances.
- 3.12 **If any checks reveal problems do not proceed with the fitting of the appliance until they have been rectified.**

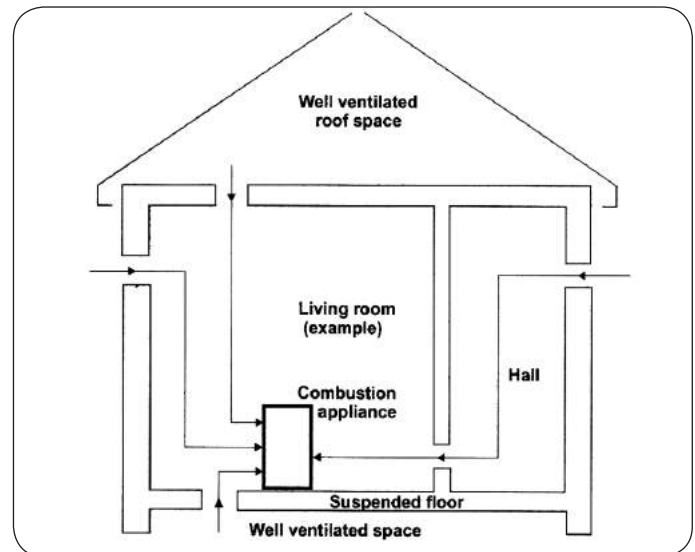

4. Minimum Dimensions - Hearth

- 4.1 The appliance must stand on a non-combustible constructional hearth which is at least 125mm thick with the minimum dimensions as shown in diagram. As this appliance can be installed in an elevated setting it is recommended to increase the 225mm hearth depth to safely contain any falling logs or embers. The higher the appliance is installed the deeper the hearth should be to protect the floor.
- 4.2 The building must have a suitable load-bearing capacity for the hearth and appliance. Consult a structural engineer for advice before proceeding.
- 4.3 When fitting into an existing hearth check that the appliance complies with current construction regulations and is at least the minimum sizes shown.
- 4.4 If there is no existing fireplace or chimney it is possible to construct a suitable non-combustible housing and hearth setting. The flue must be installed in accordance with all local and national regulations and current rules in force.
- 4.5 Check if adding a new chimney to your property requires planning permission.
- 4.6 Some houses are built using a timber frame construction with high levels of thermal insulation. Isolate the appliance from combustible materials, and provide sufficient ventilation to maintain the heating efficiency.

Technical Appendix - Ventilation

5. Builders Opening

Many fireplace openings have a supporting lintel. Remove the covering plaster to identify its position before starting any constructive work. Do not remove constructional lintels without making provision to support the remaining structure of the building. The appliance must not form any part of the supporting structure.

- 5.1 The chimney/flue must have a sealed connection to the appliance flue spigot.
- 5.2 The structure of the builders opening will reach high temperatures. Use insulating blockwork to reduce the heat transfer to the external walls.
- 5.3 Take care when finishing the chimney breast and surrounding area. The conducted and convected heat emitted by the appliance could be high enough to crack normal plaster. Use a high temperature plaster, or face the area with a suitable non combustible board avoiding any joints above the appliance. New plaster should be fully dried before the appliance is used, or cracking could occur.

If you are in any doubt about your ability to produce a safe opening contact your Stovax dealer for professional advice.*

6. Fire Surround Clearances

- 6.1 We recommend you obtain expert advice before proceeding with work of this nature.
- 6.2 Some finishes may discolour with heat and some lower quality products may distort, or crack, when in use.

If stone / granite / marble or any other natural material is used to construct the fire surround, or any part of it, provision should be made for expansion and movement of the parts due to heating and cooling.

If you are in any doubt about the installation requirements, or suitability of fire surrounds contact your Stovax dealer.

- 6.3 All fire surrounds should be suitable for use with solid fuel heating products.

7. Fitting Appliances On A Boat

- 7.1 If an appliance is to be fitted in a boat it must be done in accordance with the latest edition of BS 8511 (Code of Practice for the Installation of Solid Fuel Heating Appliances on Boats). The Code covers the design, installation and operation of solid fuel heating appliances that are suitable for fitting into inland waterway boats, and gives guidance on product selection, design considerations, installation requirements, inspection and testing, as well as maintenance and safe use tips.
- 7.2 Consideration should also be given to the requirements of the Boat Safety Scheme (BSS) to ensure the boat's insurance remains valid.
- 7.3 The appliance should only be installed by a competent person with experience of the latest edition of BS 8511 and the Boat Safety Scheme (BSS).

- 7.4 Secure the product to a suitably constructed non-combustible hearth.
- 7.5 All open flued appliances can be affected by temporary atmospheric conditions which may allow fumes to enter the boat. An electronic carbon monoxide detector conforming to the latest edition of BSEN50292 must be fitted and maintained.
- 7.6 Failure to safely install the appliance could endanger the boat and persons on board.



Organisations authorised to certify competence in the installation of domestic solid fuel appliances (Competent Persons Scheme):

APHC - Association of Plumbing and Heating Contractors (Certification) Ltd.
www.aphc.co.uk

BESCA - Building Engineering Services Competence Accreditation Ltd.
www.besca.org.uk

HETAS - Heating Equipment Testing and Approval Scheme Ltd.
www.hetas.co.uk

NAPIT - National Association of Professional Inspectors and Testers Ltd.
www.napit.org.uk

NICEIC - NICEIC Group Ltd.
www.niceic.org.uk

HETAS Approved Chimney Sweeps:

NACS - The National Association of Chimney Sweeps
www.chimneyworks.co.uk

APICS - The Association of Master Chimney Sweeps Ltd.
www.apics.org

The Guild of Master Chimney Sweeps -
guildofmasterchimneysweeps.co.uk

Basic Spare Parts

RVST-2DSHT RIVA STUDIO DUPLEX

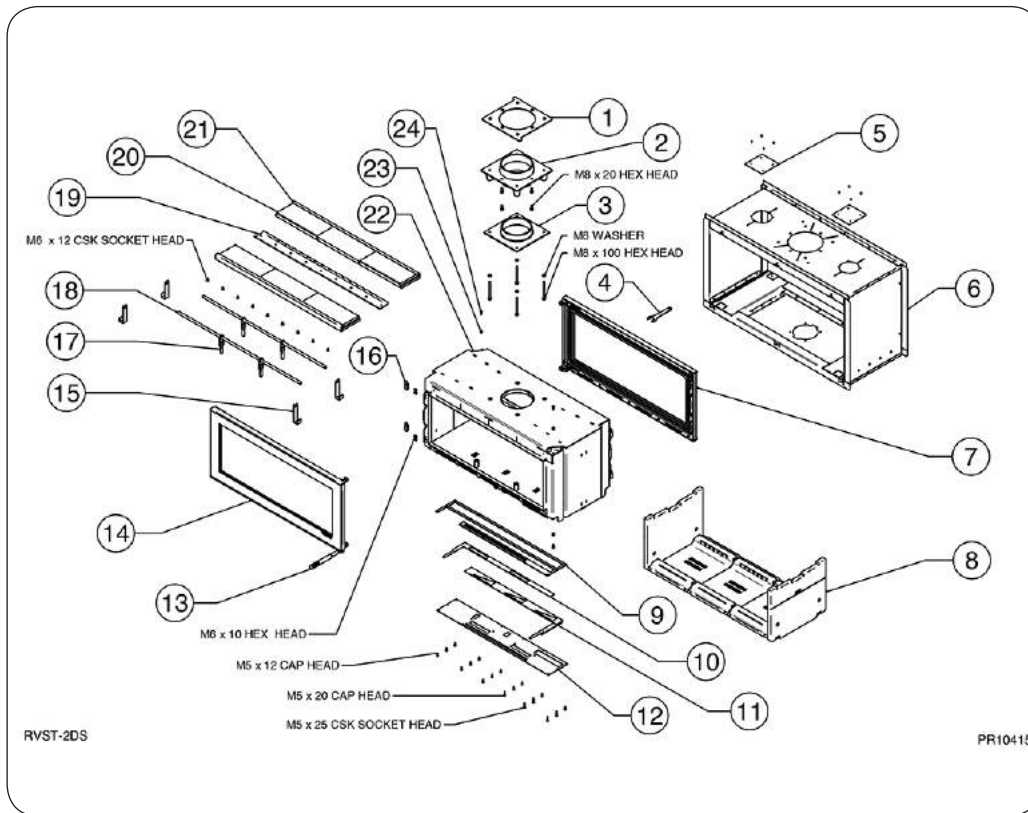

Ref. No.	Description
1	CLAMP RING
2	TOP COLLAR
3	LOWER COLLAR
4	SPANNER
5	CONVECTOR AIR COVER
6	OUTER BOX ASSY
7	DOOR ASSEMBLY CLOSED
8	BRICK ASSEMBLY
9	SLIDER PLATE
10	AIRWASH SLIDER
11	PRIMARY SLIDER ASSY
12	SLIDER PLATE
13	TOOL HANDLE
14	DOOR ASSEMBLY
15	LOG GUARD END SUPPORT
16	HINGE BLOCK ASSEMBLY
17	LOG BAR SUPPORT ASSEMBLY
18	LOG BAR
19	SECONDARY COVER
20	BAFFLE BRICK
21	BAFFLE SUPPORT
22	INNER BOX
23	CATCH ROLLER
24	CATCH ROLLER PIN

BRICK ASSEMBLY

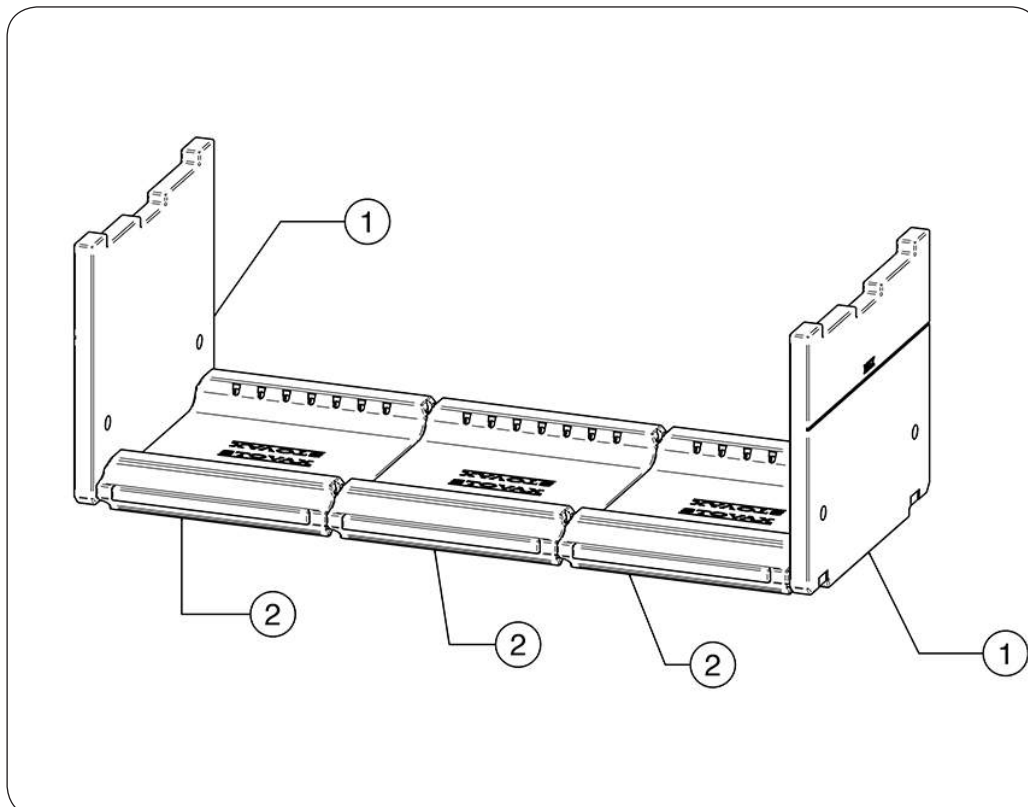

Ref. No.	Description
1	SIDE BRICK
2	BASE BRICK

Due to continual technical improvements please check online at www.stovax.com or with your Stovax retailer for the most up to date parts lists.

Basic Spare Parts

DOOR ASSEMBLY

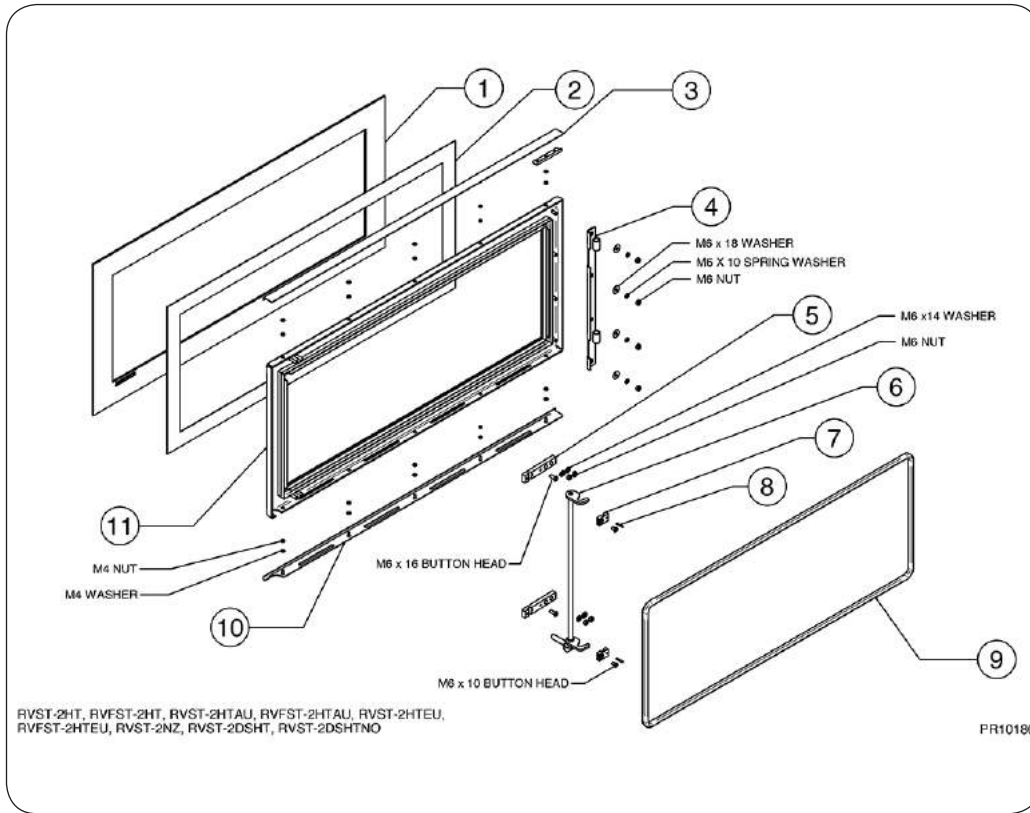

Ref. No.	Description
1	STUDIO 2 DOOR GLASS
2	GLASS ROPE
3	TOP GLASS CLAMP ASSEMBLY
4	HINGE ASSEMBLY
5	LOWER CATCH BLOCK
6	DOOR CATCH ASSEMBLY
7	UPPER CATCH BLOCK
8	SPIROL PIN Ø3 X 18LG
9	DOOR ROPE
10	BOTTOM GLASS CLAMP
11	DOOR FRAME ASSEMBLY

DOOR ASSEMBLY - CLOSED DOOR

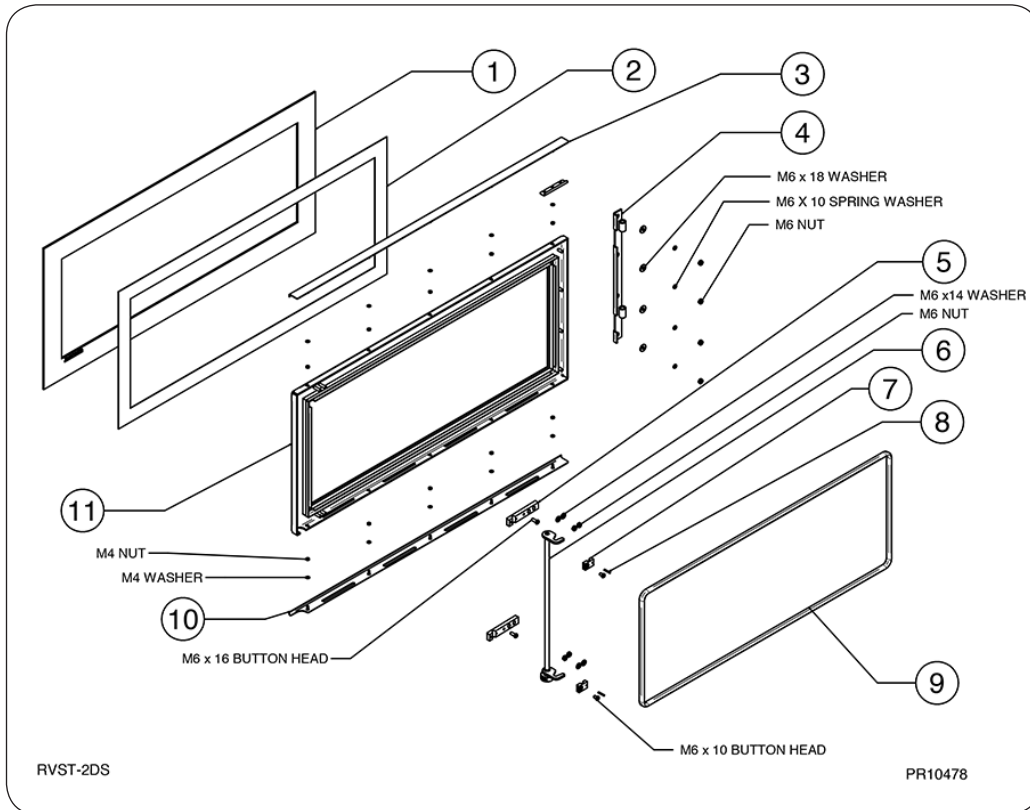

Ref. No.	Description
1	STUDIO 2 DOOR GLASS
2	GLASS ROPE
3	TOP GLASS CLAMP ASSEMBLY
4	HINGE ASSEMBLY
5	UPPER CATCH BLOCK
6	CATCH ASSEMBLY WELDED
7	LOWER CATCH BLOCK
8	SPIROL PIN Ø3 X 18LG
9	DOOR ROPE
10	BOTTOM GLASS CLAMP
11	DOOR FRAME ASSEMBLY

Due to continual technical improvements please check online at www.stovax.com or with your Stovax retailer for the most up to date parts lists.

Service Records

1ST SERVICE

Date of Service:.....

Next Service Due:.....

Signed:.....

Dealer's Stamp/HETAS Registration Number

3RD SERVICE

Date of Service:.....

Next Service Due:.....

Signed:.....

Dealer's Stamp/HETAS Registration Number

5TH SERVICE

Date of Service:.....

Next Service Due:.....

Signed:.....

Dealer's Stamp/HETAS Registration Number

7TH SERVICE

Date of Service:.....

Next Service Due:.....

Signed:.....

Dealer's Stamp/HETAS Registration Number

9TH SERVICE

Date of Service:.....

Next Service Due:.....

Signed:.....

Dealer's Stamp/HETAS Registration Number

2ND SERVICE

Date of Service:.....

Next Service Due:.....

Signed:.....

Dealer's Stamp/HETAS Registration Number

4TH SERVICE

Date of Service:.....

Next Service Due:.....

Signed:.....

Dealer's Stamp/HETAS Registration Number

6TH SERVICE

Date of Service:.....

Next Service Due:.....

Signed:.....

Dealer's Stamp/HETAS Registration Number

8TH SERVICE

Date of Service:.....

Next Service Due:.....

Signed:.....

Dealer's Stamp/HETAS Registration Number

10TH SERVICE

Date of Service:.....

Next Service Due:.....

Signed:.....

Dealer's Stamp/HETAS Registration Number

STOVAX

Stovax Ltd, Falcon Road, Sowton Industrial Estate, Exeter, Devon, England EX2 7LF
Tel: (01392) 474011 Fax: (01392) 219932 E-mail: info@stovax.com www.stovax.com

E & O E