

Uno 1, 2, 4

NO	Monteringsanvisning	2
GB	Installation- and user manual	9
DE	Montageanleitung	16
FR	Manuel d'installation	26

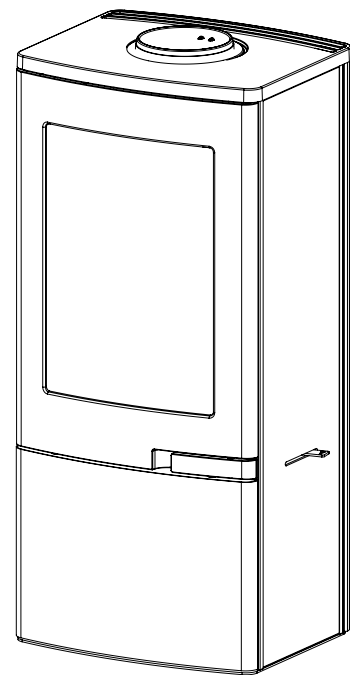

Product no: 46378757/ 46378761/ 46378776
Last updated: 14.05.2013
Sintef nr: 110-0397
RRF nr: 40 13 3258

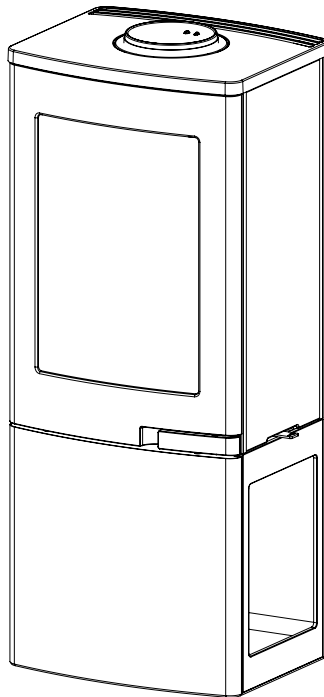
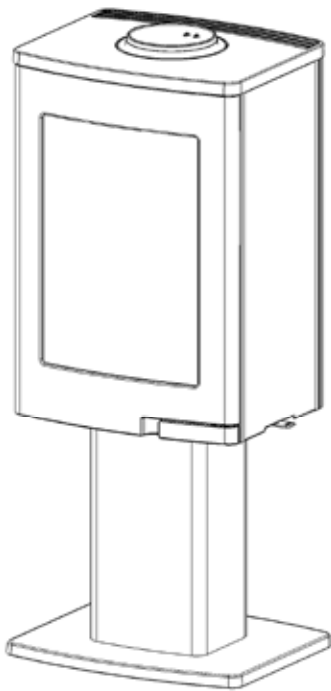

811196

INDEX

1. Before installing a new stove	9
Chimney Draught	9
Air Supply	9
2. Technical information	10
3. Distance to combustible material	10
4. Assembly	10
Releasing the stove from the pallet	10
Operating Control	10
Assembly of Thermotte	10
Adjustment of Legs	11
Flue Outlet Collar	11
Rear connection	11
Connecting the Flue	11
Fresh Air Supply Set	11
Removing the self closing door mechanism	11
Ignition air vent control	11
5. Lighting the fire for the first time	12
6. Maintenance	12
Cleaning and inspection	12
Ashes	12
Thermotte™ Insulating Plates	12
Door and glass	13
7. Warranty	13
8. Advice on lighting a fire	13
Some advice in case of combustion problems	15

1. Before installing a new stove

All our products are tested according to the latest European requirements and also **to the Norwegian standard NS 3058 and NS 3059**, which include particle tests. However, several European countries have local regulations for installation of fireplaces, which change regularly. It is the responsibility of the client that these regulations are complied with in the country/region where the fireplace is installed. Nordpeis AS is not responsible for incorrect installation.

Important to check

(please note that this list is not exhaustive):

- distance from firebox to combustible/flammable materials
- insulation materials/requirements between fireplace surround and back wall
- size of floor plates in front of fireplace if required
- flue connection between firebox and chimney
- insulation requirements if flue passes through a flammable wall

Chimney draught

Compared with older models, the clean burning inserts of today put significantly higher demands on the chimney. Even the best insert will not work properly if the chimney does not have the right dimensions or is not in good working order. The draught is mainly controlled by gas temperature, outside temperature, air supply as well as the height and inner diameter of the chimney. The diameter of the chimney should never be less than that of the flue/chimney collar. For draft requirements at nominal heat output, see technical table

The draught increases when:

- The chimney becomes warmer than the outside air
- The active length of the chimney over the hearth increases
- Good air supply to the combustion

It can be difficult to obtain the right draught conditions in case the chimney is too large relative to the insert, as the chimney does not heat up well enough. In such cases you may want to contact professional for evaluation of possible measures. Draught that is too strong can be controlled with a damper. If necessary, contact a chimney sweeper.

Air supply

A set for fresh air supply is available as an accessory. This will ensure that the air supply to the combustion chamber is less affected by ventilation systems, kitchen fans and other factors which can create a down-draught in the room. In all new constructions, we strongly recommend the product is designed and prepared for direct supply of outside air. In older houses also, the use of fresh air supply set is also recommended. Insufficient air supply can cause poor draught and thereby low combustion efficiency and the problems this entails: soot stains on the glass, inefficient utilisation of the wood and a soot deposits in the chimney.

For your own safety, fully comply with the assembly instructions. All safety distances are minimum distances. Installation of the insert must comply with the current rules and regulations of the country where the product is installed. . Nordpeis AS is not responsible for wrongly assembled stoves.

The illustrations indicate the approximate centre height of the recess for the flue. Consider possible inclination of the flue prior to perforating the chimney. Distortions in floors and walls may also influence the height. Place the stove for accurate height and positioning of the flue/chimney connection.

Subject to errors and changes.

For the latest updated version go to www.nordpeis.com.

2. Technical information

The stoves from Nordpeis all have secondary combustion and are clean burning. The combustion takes place in two phases: first the wood burns and then the gases from the fumes are lit by the hot air. This ensures that these new stoves have minimal emissions of soot particles and un-burnt gases (such as CO) and are thus better for the environment. Clean burning stoves require a small amount of wood in order to obtain a good heat output. Use exclusively clean and dry wood. We recommend seasoned hardwood with a maximum moisture content of 20%.

Material	Sheet steel
Surface treatment	Heat resistant paint
Weight (kg)	
Uno 1	84
Uno 2	92
Uno 4	88
Draught system	Air vent control with start up air setting
Combustion system	Secondary combustion (Clean burn system)
Combustion air consumption (m³/h)	8
Operating range, Clean burn (kW)	3,9 - 6
Heating area (m2)	55 - 90
Maximum fuel length (cm)	30
Flue outlet	Top and rear
Flue (Ø mm)	Outer* 150 *Alternative versions exists due to National requirements
Flue gas temperature at flue connector (°C)	320
Draft at flue connector recommended (Pa)	15 - 25
Data according to EN 13 240	
Nominal heat output (kW)	4
Efficiency (%)	81,8
CO @ 13% O₂ (%)	0,07
Flue gas temperature (°C)	262
Draft (Pa)	12
Fuel recommended	Wood logs
Fuel length recommended (cm)	25
Fuel charge (kg)	0,78
Refueling interval (minutes)	45
Opening of the air vent control (%)	33
Operation	Intermittent*

* Intermittent combustion refers to normal use of a fireplace, i.e. new wood is inserted when the previous load has burned down to ember

3. Distance to combustible material

Ensure that the safety distances are respected (FIG 1).

When connecting a steel chimney to the top outlet use the security distances required from the manufacturer.

4. Assembly

The following tools are necessary:

- 5 mm Allen key (included)
- 10/17 mm wrench (included)
- Screwdriver

Releasing the stove from the pallet:

Uno 1: Remove the screws holding the back cover on the pedestal. Remove the back cover to access the screws holding the stove to the pallet. Remove the screws using a 10mm wrench. Put the back cover back in place and fasten the screw holding it.

Uno 2: The stove is fixed to the pallet both front and rear. Use a 10mm wrench to remove the transport locks fitted through the back plate of the product. To access the screws in front, the panel under the door must be removed. Open the door and pull the lower panel carefully outwards and up. Loosen the screws and push the product forward to release it from the pallet.

Uno 4: Open the door under the combustion chamber. Remove the fitting covering the leg adjustment and the four screws holding the product to the pallet.

Operating control

When the stove is in an upright position, and prior to connecting it, control that all functions are easy to manoeuvre and appear satisfactory.

Door (FIG 2)	
Handle is pulled out	Open
Handle is pushed in	Close

Air vent (FIG 2)	
Forward	Closed
Backward	Open

Disassembling / Assembling Thermotte FIG 11-20

Disassembling the Thermotte

FIG 12. Carefully pull the lower end of the back plate diagonally towards the door. Leave it at an angle as shown in the illustration.

FIG 13. Remove the smoke baffle by moving it carefully to one side and clear of the rail on the other side. Place the smoke baffle at an angle and carefully remove it through the door.

FIG 14. Remove the back plate by tilting it carefully through the door.

FIG 15. Lift the bottom plate up on one side and the the other.

Assembling the Thermotte

FIG 16. Carefully tilt the bottom plate through the door opening. Carefully lower it down on one side before lowering it on the other.

FIG 17. Tilt the back plate through the door and place it at an angle (bottom part towards the door) . Leave the back plate at this angle FIG 18.

FIG 19. Carefully tilt the smoke baffle through the door and place it evenly above the upper rails, one side at the time. Make sure the smoke baffle is centered FIG 19C.

FIG 20. When the smoke baffle is in place, carefully push the bottom of the back plate in place.

Adjustment of legs

Uno 1/2: Do not have adjustable legs

Uno 4

Open the door under the combustion chamber FIG 3. Remove the fitting covering the leg adjustment and adjust the legs with a 17 mm wrench.

In addition, Uno 4 has optional legs sold separately. See manual Uno Legs for details.

Attention! Adjusting the legs affects both the top and rear connection height.

Flue outlet collar

Uno is delivered standard with a top flue outlet collar.

Rear connection FIG 4-10

Remove the top plate and use a 5mm Allen key to release and remove the smoke collar FIG 4.

Loosen the screws holding the brackets for the back plate FIG 5.

Carefully pull the brackets upwards FIG 6A and pull the back plate backwards and off FIG 6B.

Remove the cut out in the back plate FIG 7.

Remove the rear smoke outlet cover FIG 8, and place it over the top outlet FIG 9A. Move the smoke collar on the back of the product and fasten it FIG 9B.

Put the back plate back in place and tighten the screws holding it in place FIG 10.

Adjusting the door under the combustion chamber, Uno 4

The hinges can be adjusted according to FIG 21

Connecting the flue

Please be aware when connecting the 150 mm flue to the smoke dome that the flue is placed outside the flue outlet collar. *Alternative versions exist due to National requirements. For the flue connection to the chimney, follow the recommendations from the chimney manufacturer

Air Supply

For connecting the fresh air supply set see **FIG Uno Air 1, 2 and 4/5.**

Placement of CE mark

The CE-mark which is included should be placed on the stove.

Uno 1: The CE mark should be placed on the back of the pedestal.

Uno 2: The CE badge should be placed on the inside of the panel under the door.

Uno 4: The CE badge should be placed to the right in the compartment under the door.

Removing the self closing mechanism FIG 22

The self closing door mechanism connected to the stove at the bottom left corner. Carefully unhook the spring and remove the small screw holding the arm connected to the door. The self closing mechanism is now deactivated.

Ignition air vent control

As an integrated part of the air vent control, Uno has a ignition air vent control. By pushing the air vent control rod all the way back (max opening), the ignition air vent control will be activated.

Attention! After ignition, pull the control back to normal.

A= Ignition air vent

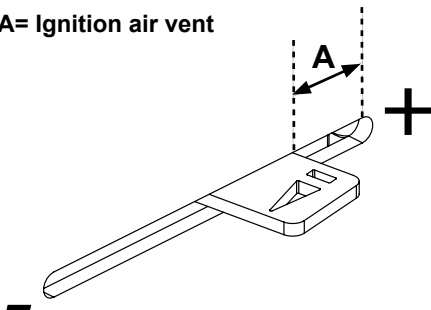

5. Lighting the fire for the first time

When the stove is assembled and all instructions have been observed, a fire can be lit.

Take care when inserting logs into the burn chamber, in order not to damage the Thermotte plates. Please note that there might be some humidity in the insulation plates which can result in a slower burn rate the first few times the insert is used. This will be resolved once the humidity has evaporated. If needed leave the door slightly open the first 2-3 times the insert is used. **It is advisable to ventilate the room well when using for the first time as the varnish on the product may release some smoke or smell.** Both the smoke and smell will disappear and are not hazardous.

Lighting a fire

Insert small, dry pieces of kindling wood, ignite and ensure the flames have established on the wood before closing the door. Open the air vent control (FIG 2) before you close the door. Additional ignition air is obtained by keeping the door slightly open. When the flames are stable and the chimney is warm, the air supply is regulated with the air vent control.

When there is a glowing layer of ash, new wood logs can be inserted. Pull the hot ember to the front of the combustion chamber when inserting new logs so that the wood is ignited from the front. Keep the door slightly open each time new logs are inserted so that the flames get established. The fire should burn with bright and lively flames.

Using the insert with low combustion effect and firing around the clock increase pollution as well as the risk for a fire in the chimney. Never allow the insert or flue to become glowing red. Turn off the air vent control should this happen. Regulation of the air vent control

takes some experience, but after a little while a natural rhythm for the fire will be found.

IMPORTANT! Always remember to open the air vent control (preferably also the door) before new wood logs are inserted into a hot burn chamber. Let the flames get a good grip on the wood before the air control setting is reduced.

When the draught in the chimney is low and the vent is closed, the gas from the firewood can be ignited with a bang. This can cause damage to the product as well as the immediate environment.

6. Maintenance

Cleaning and inspection

The insert should be inspected thoroughly and cleaned at least once per season (possibly in combination with the sweeping of the chimney and chimney pipes). Ensure that all joints are tight and that the gaskets are rightly positioned. Exchange any gaskets that are worn or deformed.

Remember that the insert must always be cold when inspected.

Ashes

The ashes should be removed at regular intervals. Be aware that the ashes can contain hot ember even several days after the fire is finished. Use a container of non-combustible material to remove the ashes. It is recommended to leave a layer of ashes in the bottom as this further insulates the burn chamber. Take care with the Thermotte plates when the ashes are removed, particularly when using an ash shovel, so as not to damage them.

Thermotte™ insulating plates

The insulating plates in the burn chamber (FIG 11) contribute to a high combustion temperature, which leads to cleaner combustion of the wood and a higher rate of efficiency. Any fissures in the plates will not reduce their insulation efficiency.

If new plates are needed, contact your dealer.

- A. Smoke baffle
- B. Backplate
- C. Bottom plate

Please note: Wood logs that are too long can cause strain and crack the plates, due to the tension created between the side plates.

Please also note that the Thermotte plates may release coloured dust when touched. Avoid touching any cast iron parts with dust on your fingers. Any visible dust on cast iron can be brushed off with the glove that is included.

Door and glass

Should there be any soot on the glass it may be necessary to clean it. Use dedicated glass cleaner, as other detergents may damage the glass. (NB! Be careful, even dedicated glass cleaner can damage the varnish on the door frame). A good advice for cleaning the glass is to use a damp cloth or kitchen roll paper and apply some ash from the burn chamber. Rub around the ash on the glass and finish off with a piece of clean and damp kitchen roll paper. NB! Only clean when the glass is cold.

Check regularly that the transition between the glass and the door is completely tight. Possibly tighten the screws that hold the glass in place - but not too hard, as this can cause the glass to crack.

Periodically, it may be necessary to change the gaskets on the door to ensure that the burn chamber is air tight and working optimally. These gaskets can be bought as a set, usually including ceramic glue.



Recycling of the ceramic glass

Ceramic glass cannot be recycled. Old glass, breakage or otherwise unusable ceramic glass must be discarded as residual waste. Ceramic glass has a higher melting temperature, and can therefore not be recycled together with glass. If mixed with ordinary glass, it would damage the raw material and could, in worst case end the recycling of glass. It is an important contribution to the environment to ensure that ceramic glass does not end up with the recycling of ordinary glass.

Packaging recycle

The packaging accompanying the product should be recycled according to national regulations.

7. Warranty

For detailed description of the warranty conditions see the enclosed warranty card or visit our website www.nordpeis.com

8. Advice on lighting a fire

The best way to light a fire is with the use of lightening briquettes and dry kindling wood. Newspapers cause a lot of ash and the ink is damaging for the environment. Advertising flyers, magazines, milk cartons and similar are not suitable for lighting a fire. Good air supply is important at ignition. When the flue is hot the draught increases and door can be closed.

Warning: NEVER use a lighting fuel such as petrol, kerosene, alcohol or similar for lighting a fire. This could cause injury to you as well as damaging the product.

Use clean and dry wood with a maximum moisture content of 20%. The wood should be dried for a minimum of 6 months after it is cut. Humid wood requires a lot of air for the combustion, as extra energy/heat is required for drying the humid wood and the heat effect is therefore minimal. This in addition creates soot in the chimney with the risk of creosote and chimney fire.

Storing of wood

In order to ensure that the wood is dry, the tree should be cut in winter and stored during the summer, covered and in a location with adequate ventilation. The wood pile must never be covered by a tarpaulin lying against the ground as the tarpaulin will then act as a sealed lid that will prevent the wood from drying. Always keep a small amount of wood indoors for a few days before use so that moisture in the surface of the wood can evaporate.

Usage

Not enough air to the combustion may cause the glass to soot. Hence, supply the fire with air just after the wood is added, so that the flames and gases in the combustion chamber are properly burnt. Open the air vent and have the door slightly ajar in order for the flames to establish properly on the wood.

Note that the air supply for the combustion also can be too large and cause an uncontrollable fire that very quickly heats up the whole combustion chamber to an extremely high temperature (when using with a closed or nearly closed door). For this reason you should never fill the combustion chamber completely with wood.

It is recommended to keep an even fire with a small amount of wood. Too many logs put on hot ember, may result in combustion air starvation, and the gases will be released unburnt. For this reason it is important to increase the air supply just after adding logs.

Choice of fuel

All types of wood, such as birch, beech, oak, elm, ash and fruit trees, can be used as fuel in the insert. Wood species have different degrees of density - the more dense the wood is, the higher the energy value. Beech,

oak and birch has the highest density.

Attention! We do not recommend using fuel briquettes/ compact wood in our products. Use of such fuel may cause the product to overheat and exceed the temperatures determined safe. Burning briquettes/ compact wood is done so at your own risk and only small amounts (max 1/3 of normal load) should be used for each load.

Warning:

NEVER use impregnated wood, painted wood, plywood, chipboard, rubbish, milk cartons, printed material or similar. If any of these items are used as fuel the warranty is invalid.

Common to these materials is that during combustion they can form hydrochloric acid and heavy metals that are harmful to the environment, yourself and the insert.

Hydrochloric acid can also corrode the steel in the chimney or masonry in a masonry chimney. Also, avoid burning with bark, sawdust or other extremely fine wood, apart from when lighting a fire. This form of fuel can easily cause a flashover that can lead to temperatures that are too high.

Warning:

Make sure the insert is not overheated - it can cause irreparable damage to the product. Such damage is not covered by the warranty.

Source "Håndbok, effektiv og miljøvennlig vedfyring" by Edvard Karlsvik SINTEF Energy Research AS and Heikki Oravainen, VTT.
<http://www.eufirewood.info>

Some advice in case of combustion problems

Error	Explanation	Solution
No draught	The chimney is blocked	Contact a chimney sweeper / dealer for more information or clean the flue, smoke baffle and burn chamber.
	The flue is sooty or there is accumulated soot on the smoke baffle	
	The smoke baffle is wrongly positioned	Verify the assembly of the smoke baffle - see assembly instructions.
The stove release smoke when lighting the fire and during combustion	Downdraught in the room caused by no draught, that the house is too "air tight".	Light the fire with an open window. If this helps, more/bigger vents must be installed in the room.
	Downdraught in the room – caused by extractor and/or central ventilation system that pulls too much air out of the room.	Turn off/regulate extractor and/or other ventilation. If this helps, more vents must be installed.
	The flues from two fireplaces/stoves are connected to the same chimney at the same height.	One flue must be repositioned. The height difference of the two flue pipes must be of at least 30 cm.
	The flue is in a declining position from the smoke dome to the chimney.	The flue must be moved so that there is an inclination of at least 10° from smoke dome to chimney. Possibly install a smoke suction device*.
	The flue is too far into the chimney.	The flue must be reconnected so that it does not enter into the chimney but ends 5 mm before the chimney inner wall. Possibly install a smoke suction device*.
	Soot hatch in the basement or attic that is open and thus creating a false draught.	Soot hatches must always be closed. Hatches that are not tight or are defected must be changed.
	Damper/top draught vents or doors on fireplaces that are not in use are open and create a false draught.	Close damper, doors and top draught vents on fireplaces that are not in use.
	An open hole in the chimney after that a fireplace has been removed, thus creating a false draught.	Holes must be completely sealed off with masonry.
	Defect masonry in the chimney, e.g. it is not airtight around the flue pipe entry and/or broken partition inside the chimney creating a false draught.	Seal and plaster all cracks and sites that are not tight.
	The cross-section in the chimney is too large which results in no or very low draught.	The chimney must be refitted, possibly install a smoke suction device*.
	The cross-section in the chimney is too small and the chimney cannot carry out all the smoke.	Change to a smaller fireplace or build new chimney with a larger cross section. Possibly install a smoke suction device*.
The chimney is too low and hence a poor draught.	Increase the height of the chimney and/or install a chimney cap/ smoke suction device*.	
The stove releases smoke inside when it is windy outside.	The chimney is too low in relationship to the surrounding terrain, buildings, trees etc.	Increase the height of the chimney and/or install a chimney cap/ smoke suction device*.
	Turbulence around the chimney due to the roof being too flat.	Increase the height of the chimney and/or install a chimney cap/ smoke suction device*.
The stove does not heat sufficiently.	The combustion receives too much oxygen due to a leakage under the lower border of the stove or too strong chimney draught. Difficult to regulate the combustion and the wood burn up too quickly.	Any possible leakage must be sealed off. A draught regulator or possibly a damper can reduce the chimney draught. NB! A leakage of only 5 cm ² is enough for 30% of the heated air to disappear.
Too much draught	The smoke buffer is wrongly positioned.	Verify the positioning of the smoke buffer – see assembly instructions.
	In case of using oven-dried wood, this requires less air supply than when using normal wood.	Turn down the air supply.
	The gaskets around the door are worn and totally flat.	Replace the gaskets, contact your dealer.
	The chimney is too large.	Contact chimneysweeper or other professional for more details.
The glass is sooty	The wood is too wet.	Only use dry wood with a humidity of maximum 20%.
	The air vent control is closed too tightly.	Open the air vent control to add air to the combustion. When new wood logs are inserted all vent controls should be completely opened or the door slightly opened until the flames have a good take on the wood.
White glass	Bad combustion (the temperature is too low)	Follow the guidelines in this user guide for correct combustion.
	Using wrong material for combustion (such as: painted or impregnated wood, plastic laminate, plywood etc)	Ensure to use only dry and clean wood.
Smoke is released when the door is opened	A levelling out of pressure occurs in the burn chamber.	Open the air vent control for about 1 min before opening the door – avoid opening the door too quickly.
	The door is opened when there is a fire in the burn chamber.	Open the door carefully and/or only when there is hot ember.
White smoke	The combustion temperature is too low.	Increase the air supply.
	The wood is humid and contains water damp.	Ensure to use only dry and clean wood.
Black or grey/black smoke	Insufficient combustion.	Increase the air supply.

FIG 1

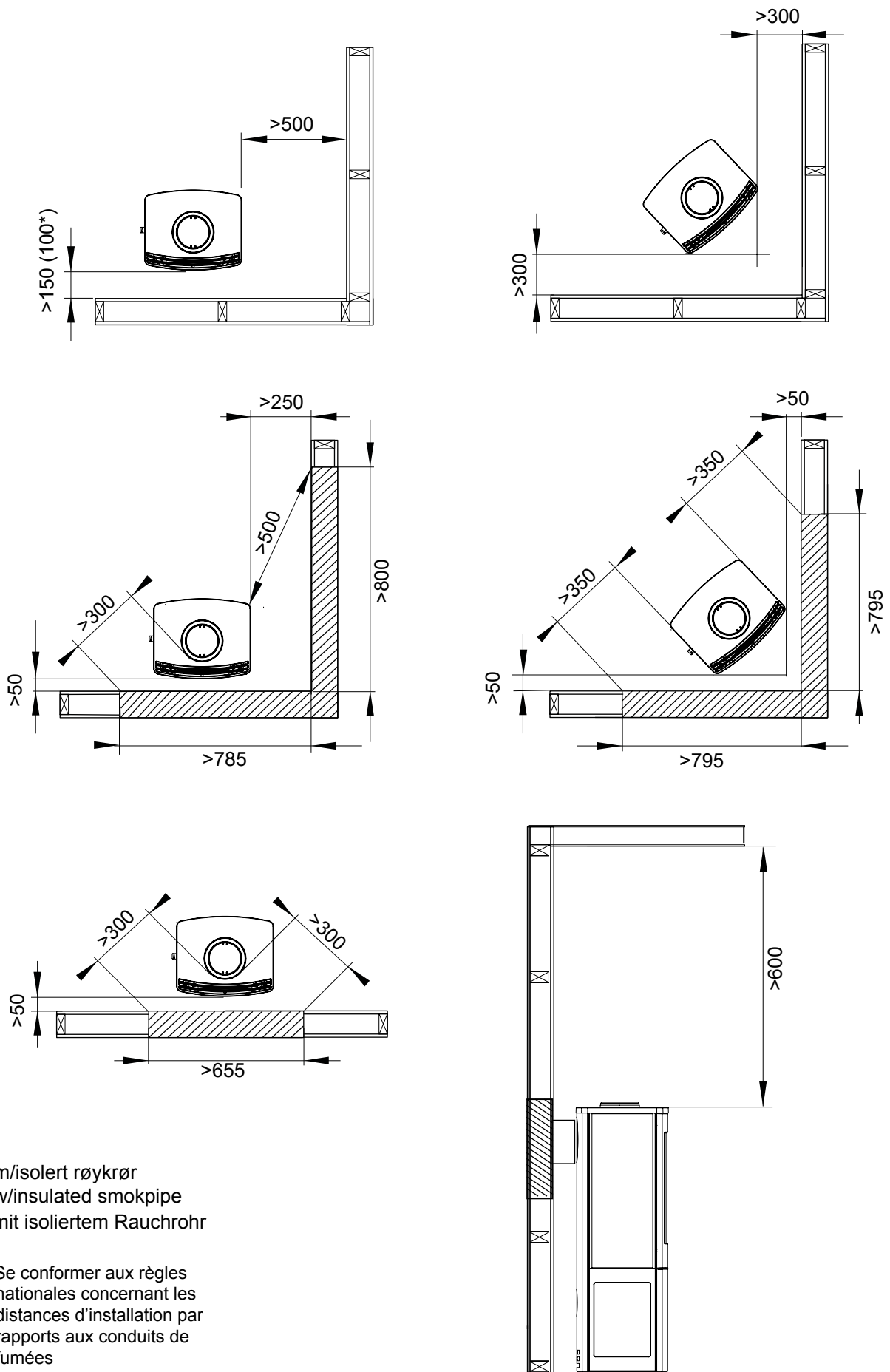

- * m/isolert røykrør
- * w/insulated smokpipe
- * mit isoliertem Rauchrohr

* Se conformer aux règles nationales concernant les distances d'installation par rapports aux conduits de fumées

Uno 1 =mm

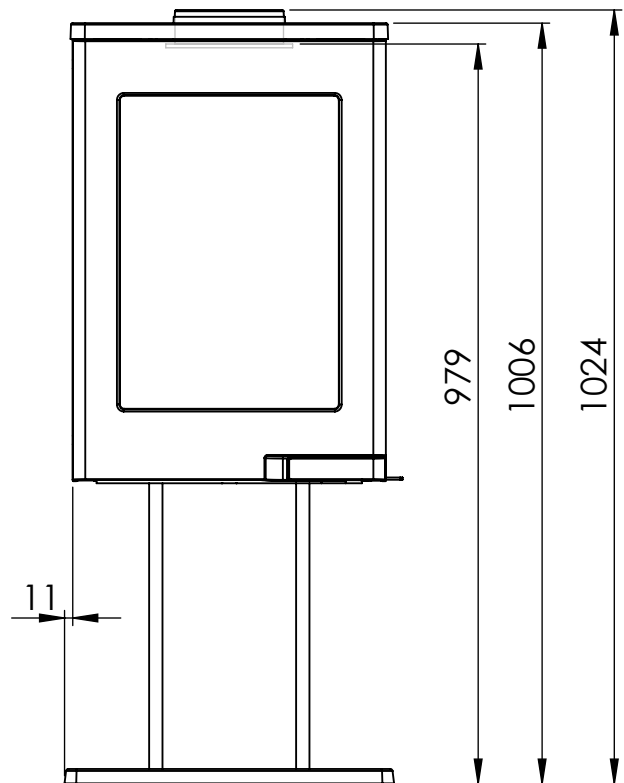
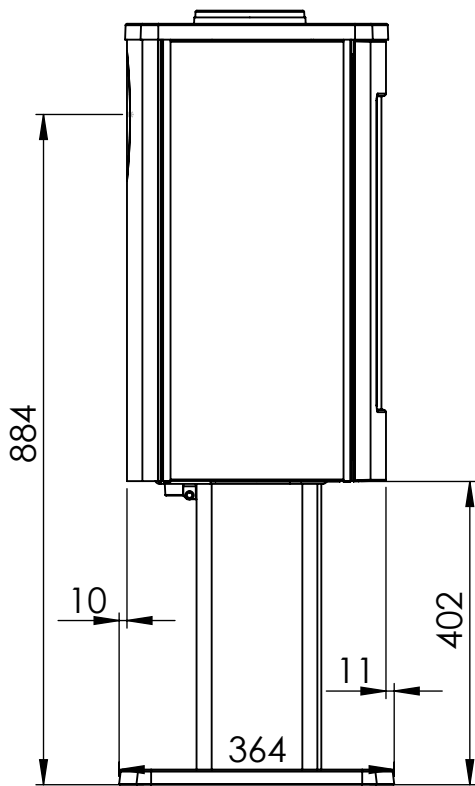
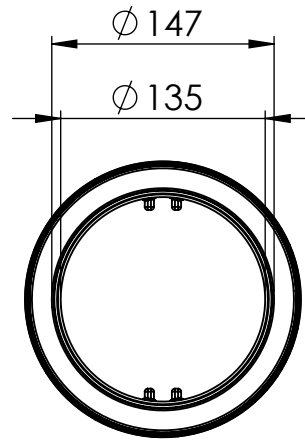
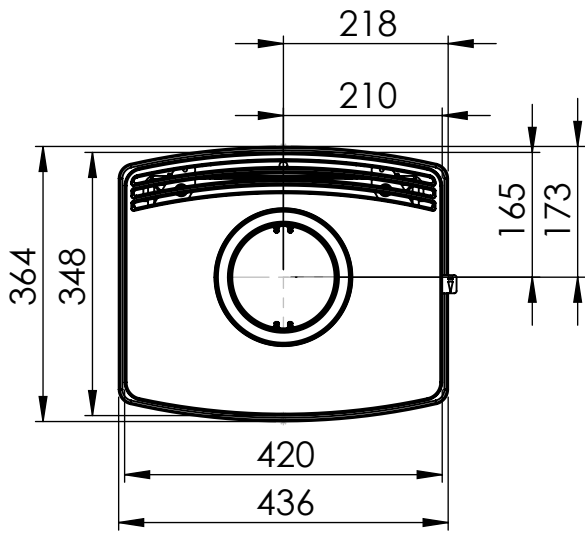

Uno 1 =mm AIR

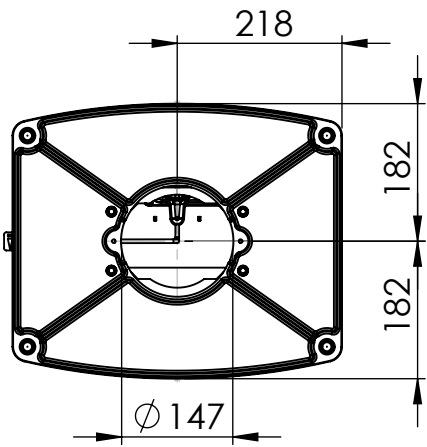
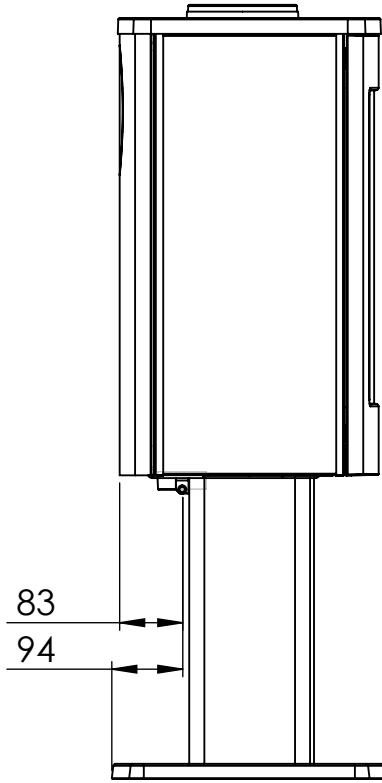
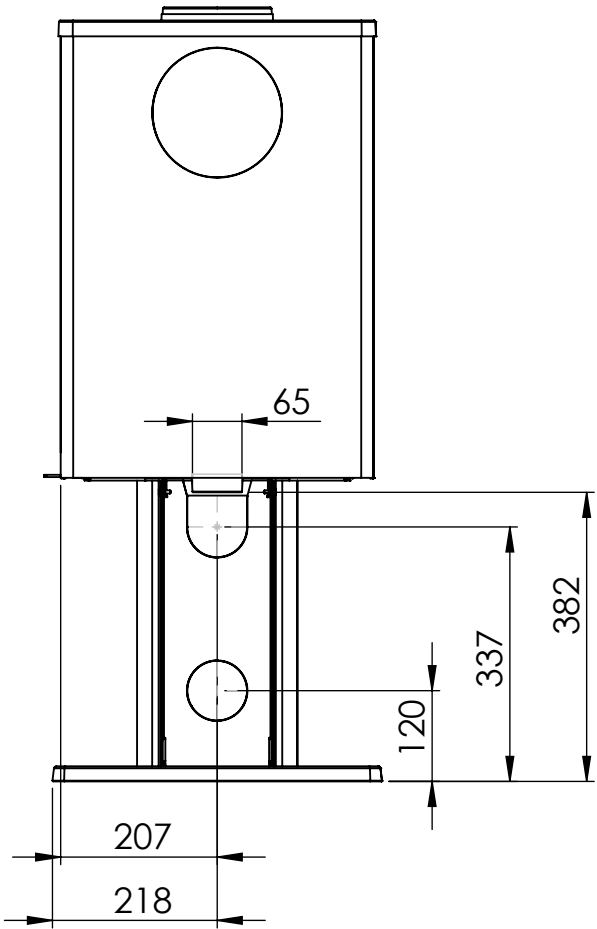

Uno 2 =mm

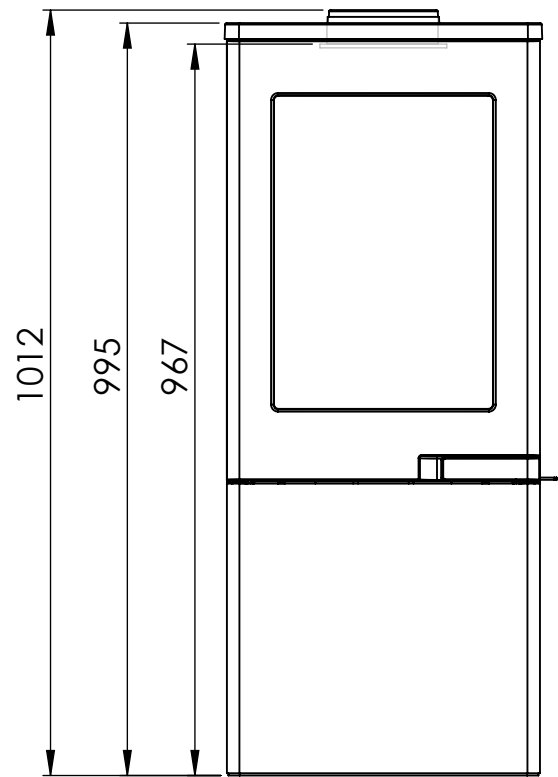
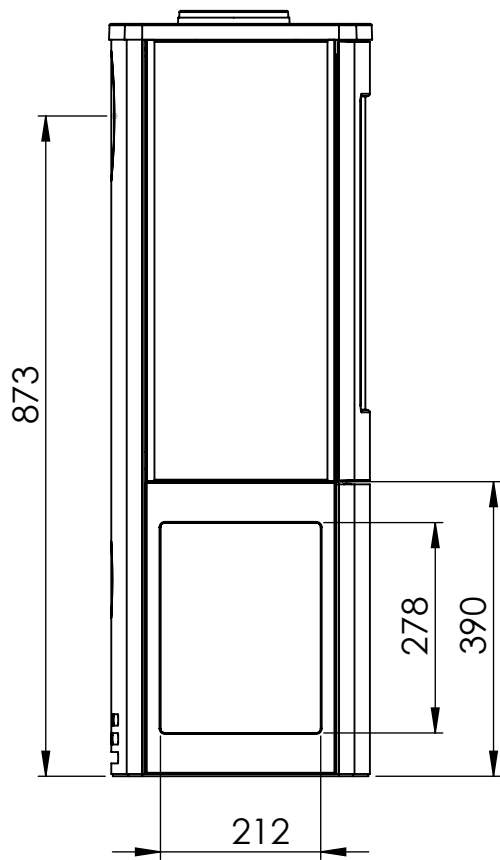
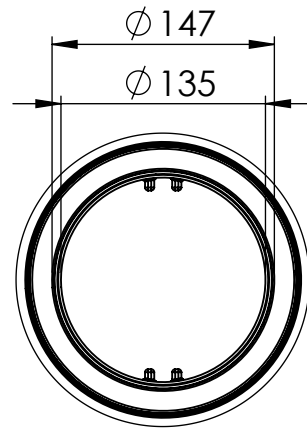
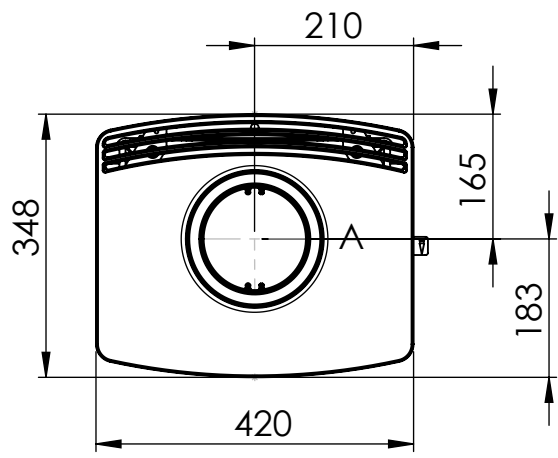

Uno 2 =mm AIR

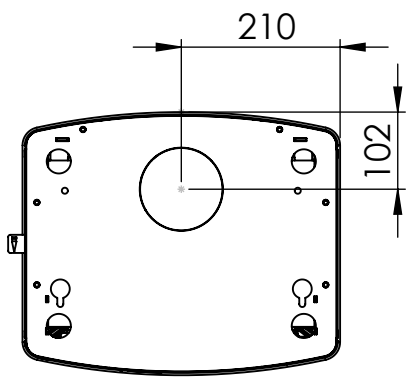
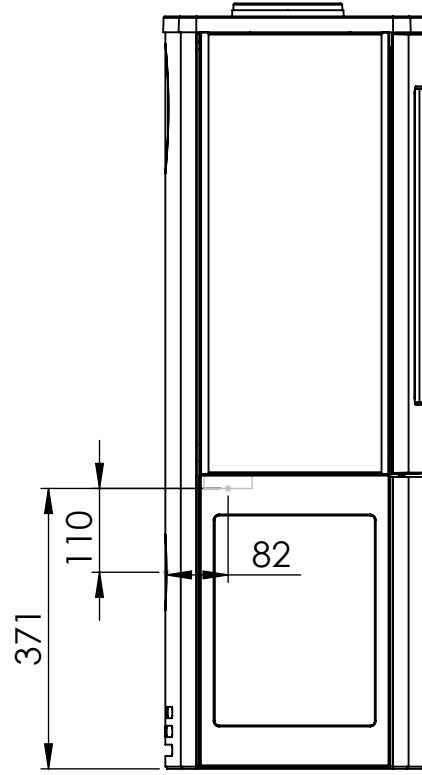
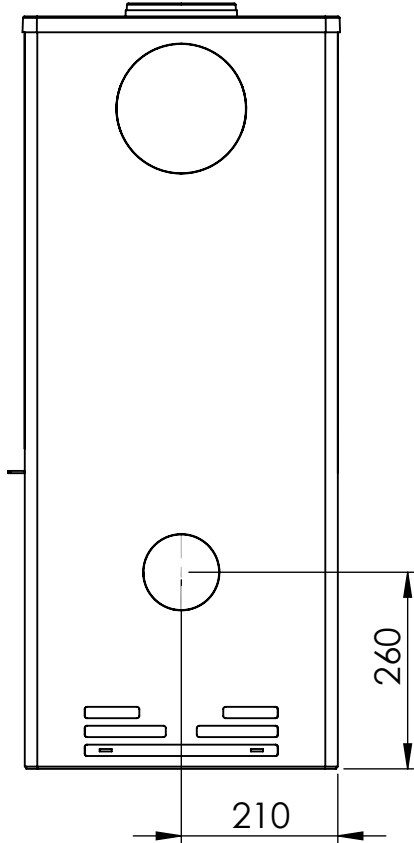

Uno 4 =mm

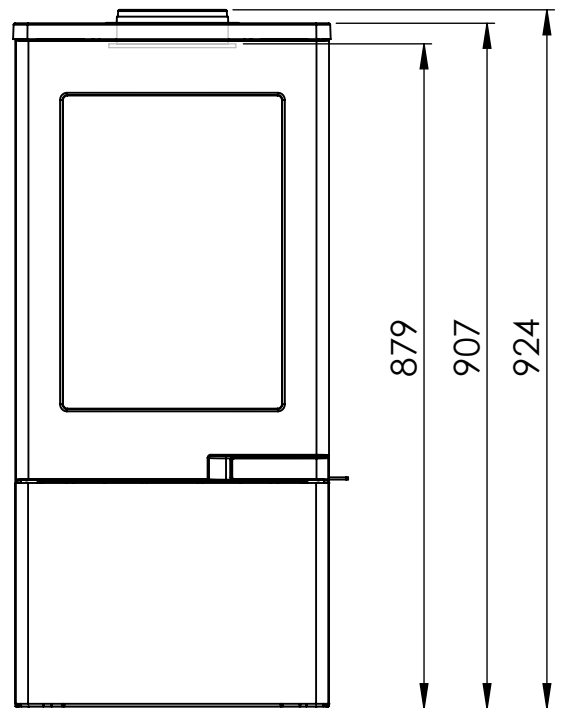
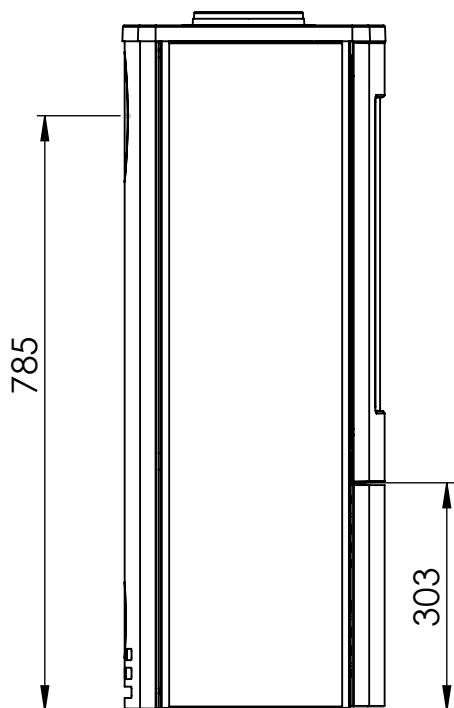
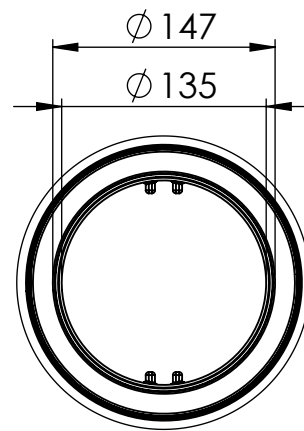
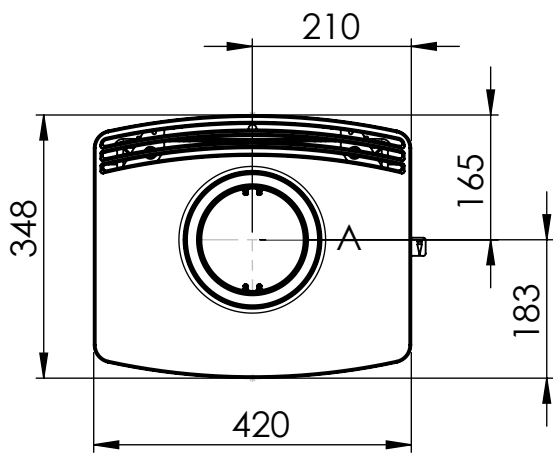

Uno 4 =mm AIR

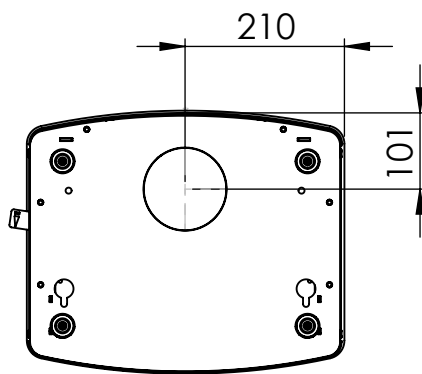
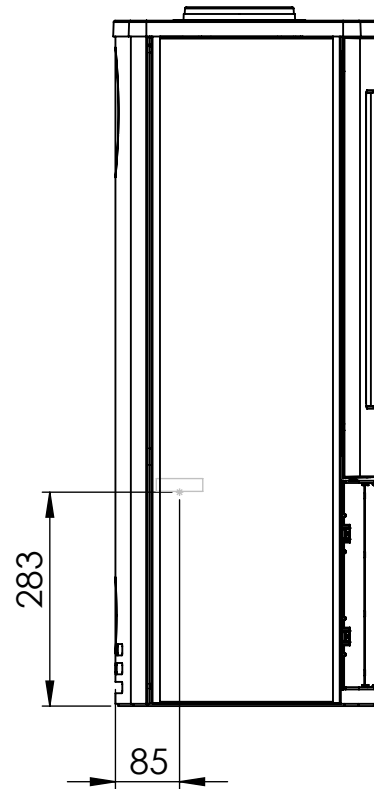
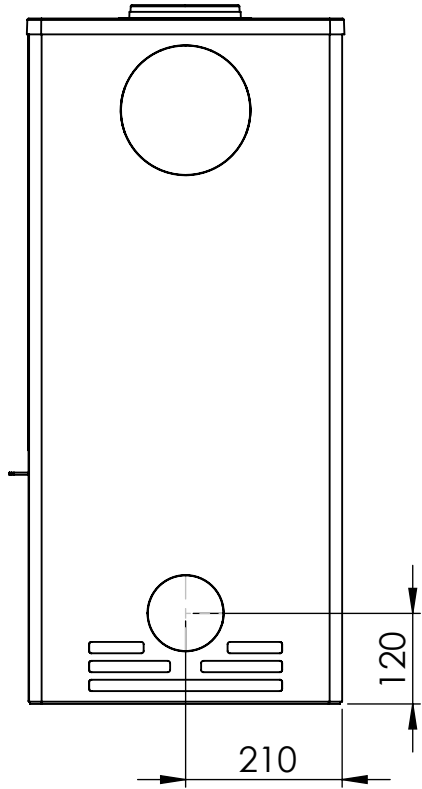

FIG 2

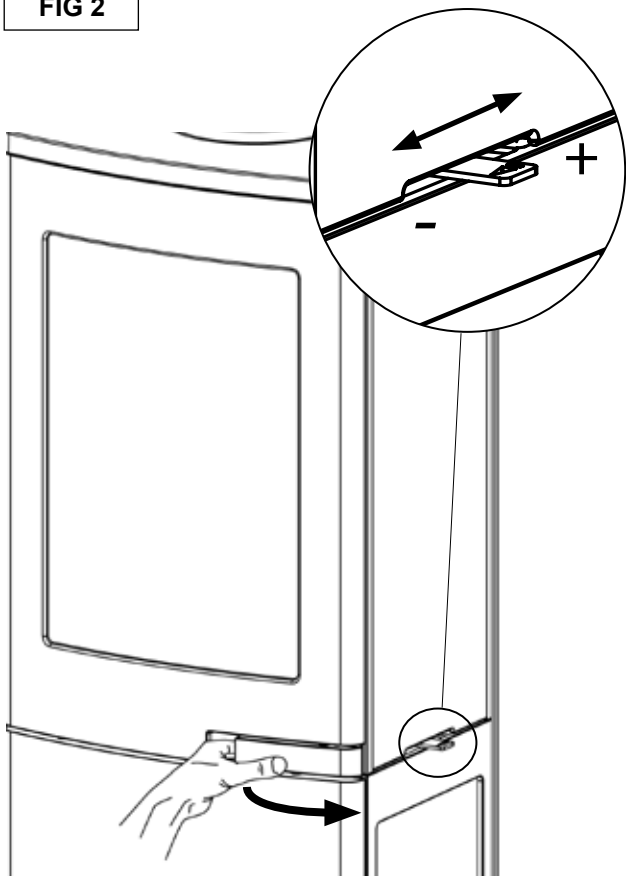

FIG 3

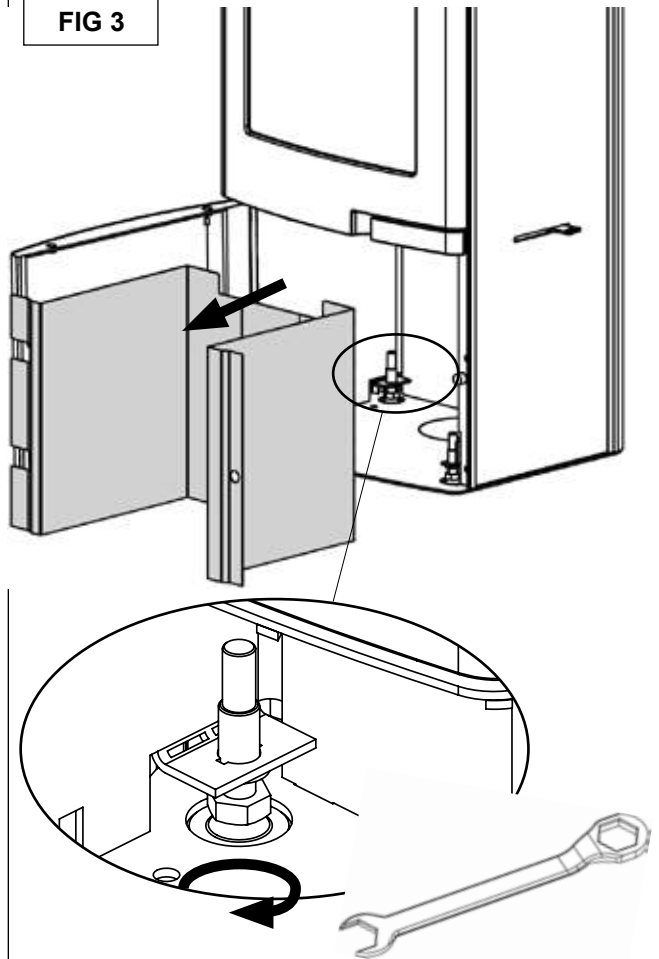

FIG 4

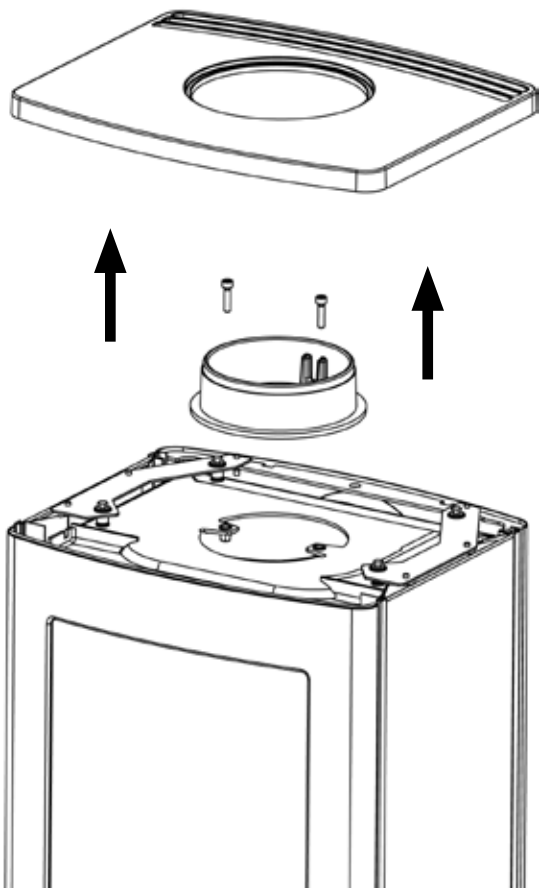

FIG 5

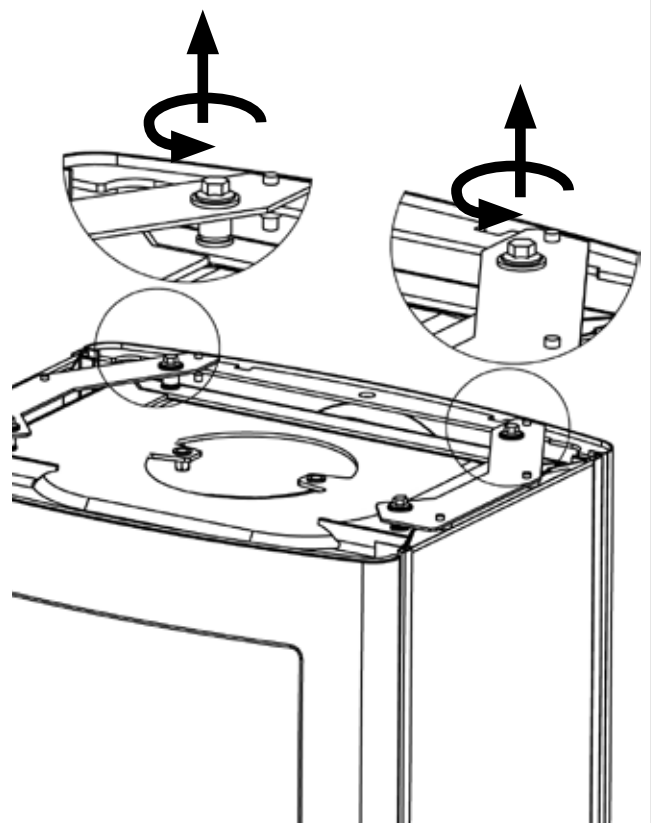

FIG 6

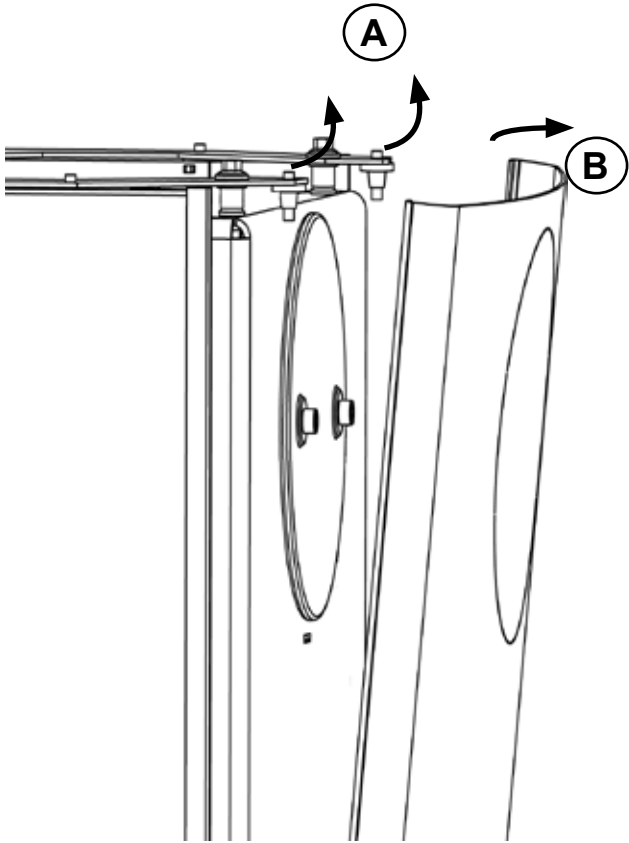

FIG 7

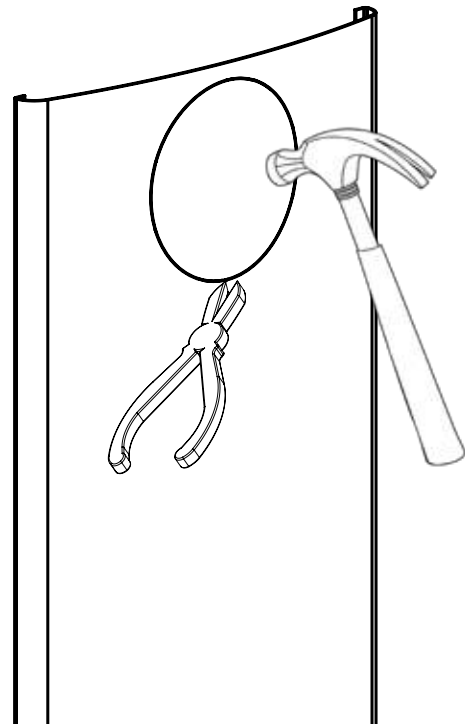

FIG 8

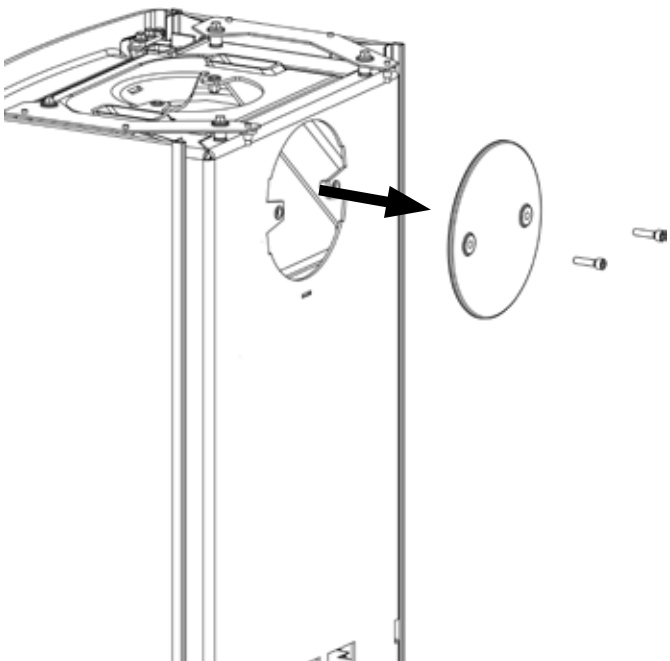

FIG 9

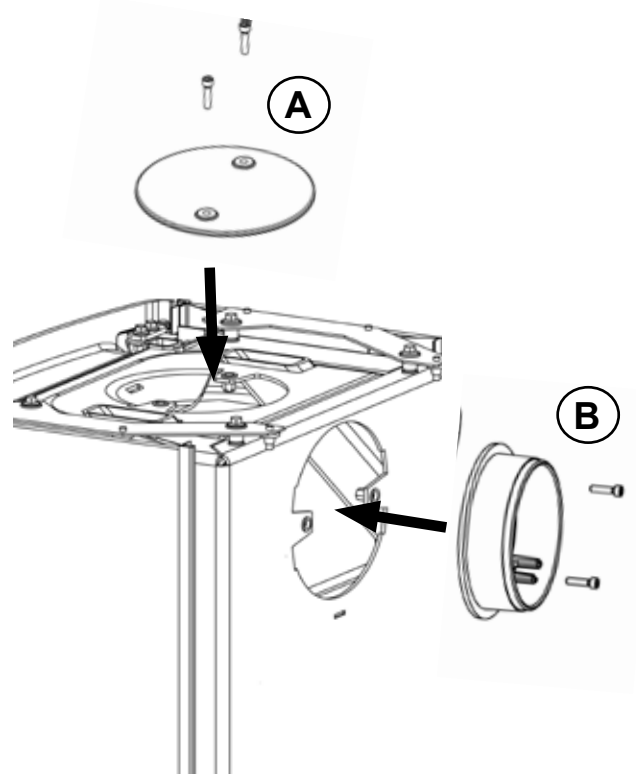

FIG 10

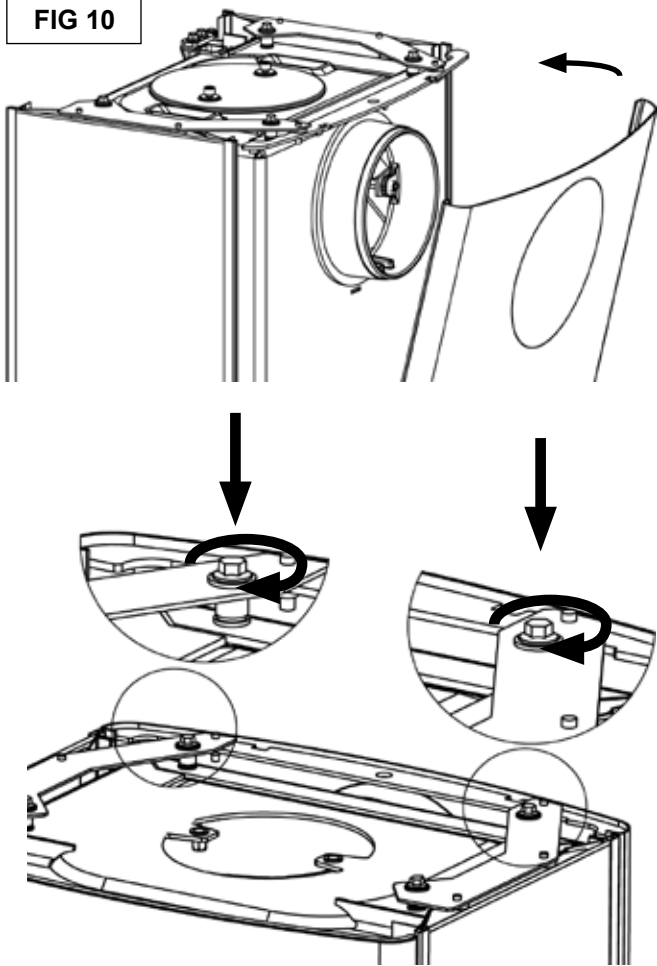

FIG 11

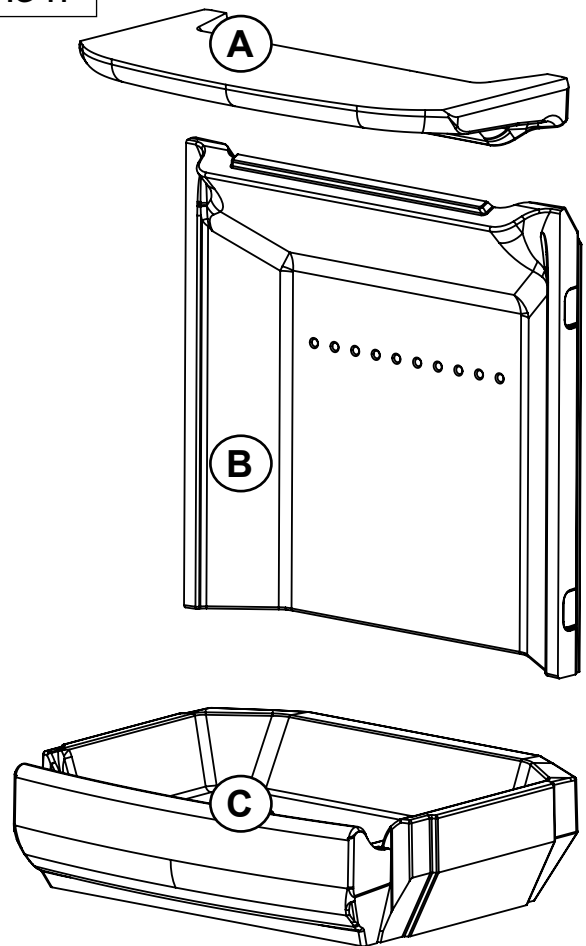

FIG 12

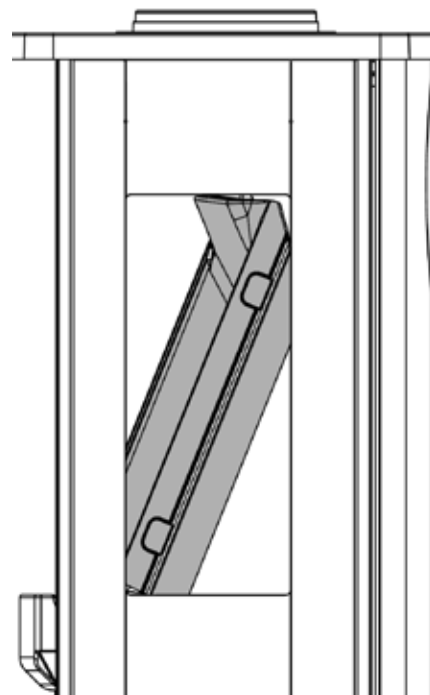
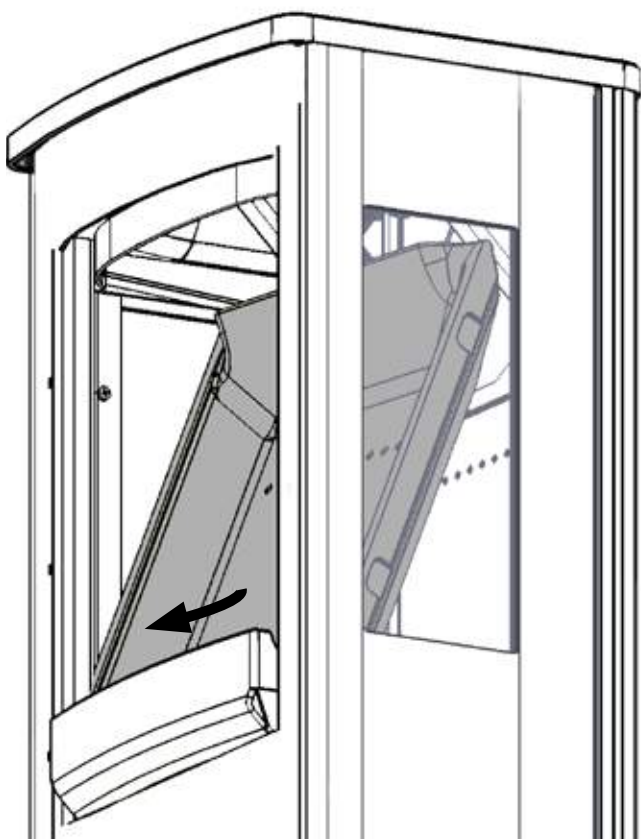

FIG 13

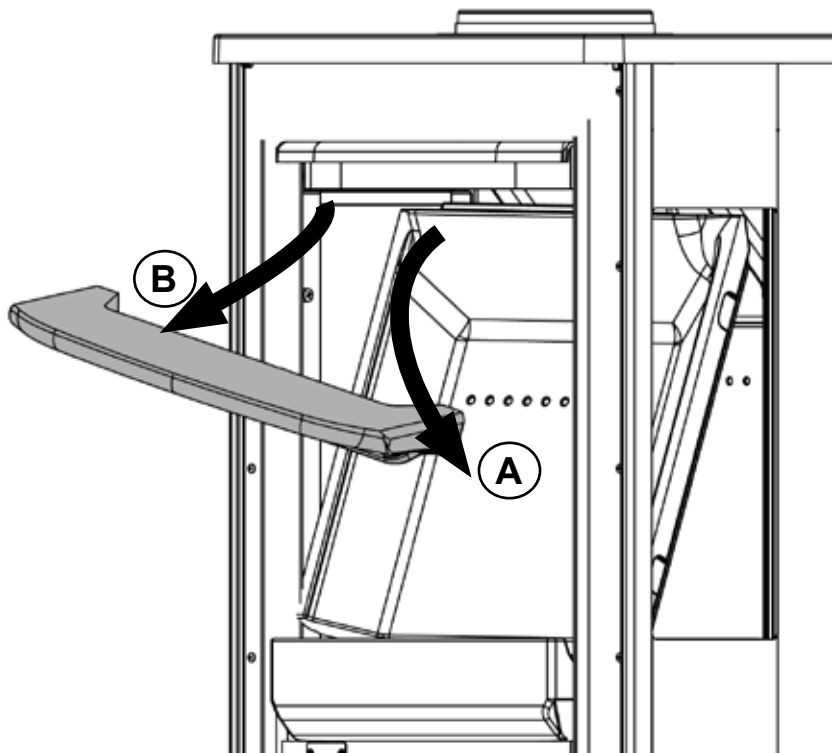

FIG 14

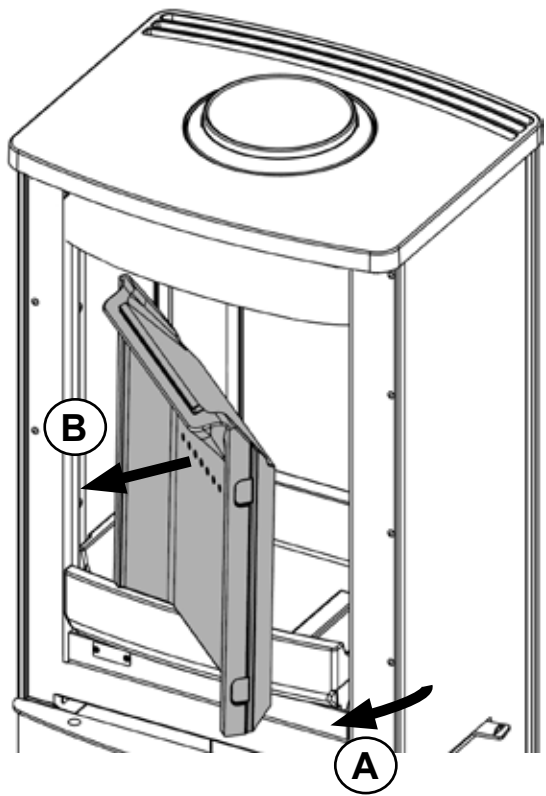

FIG 15

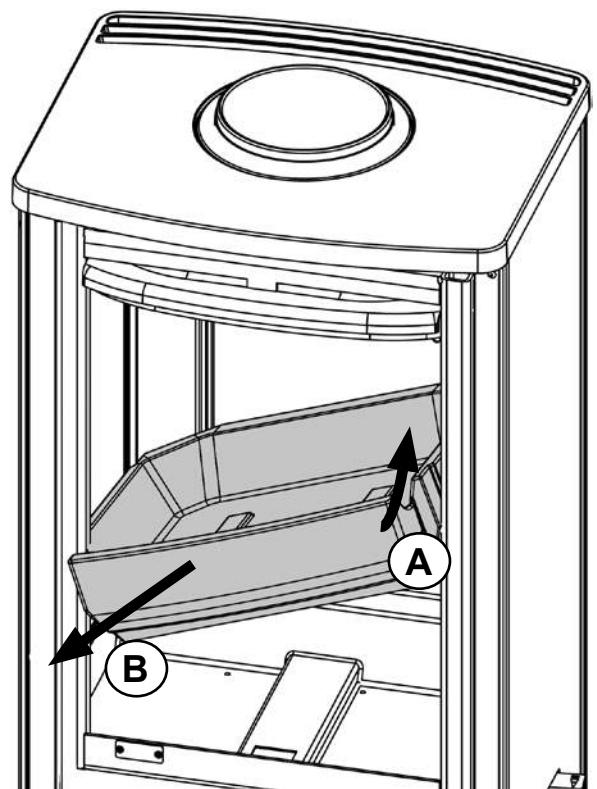

FIG 16

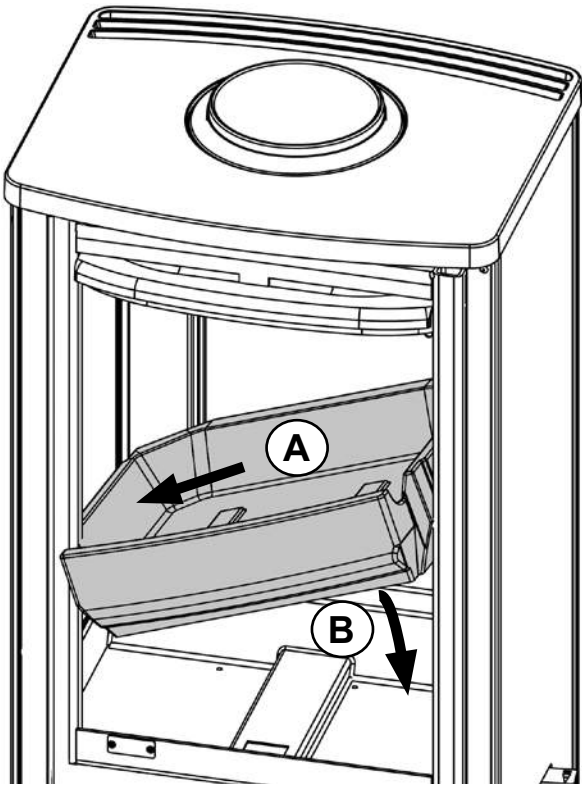

FIG 17

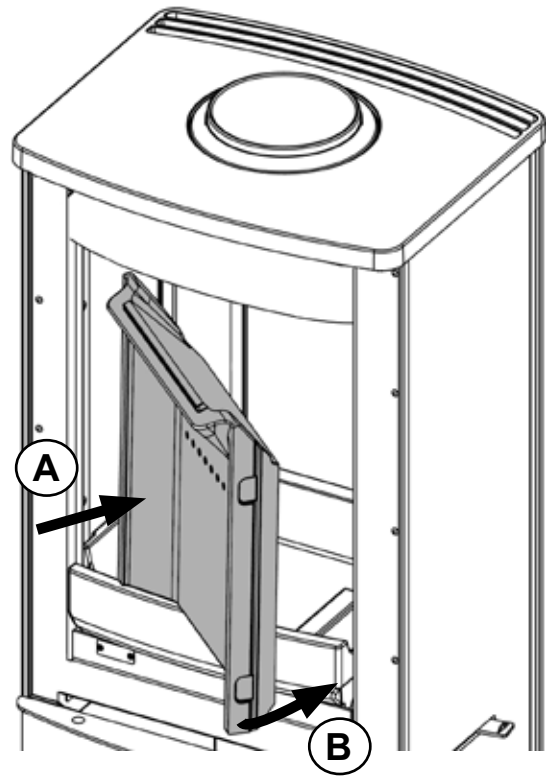

FIG 18

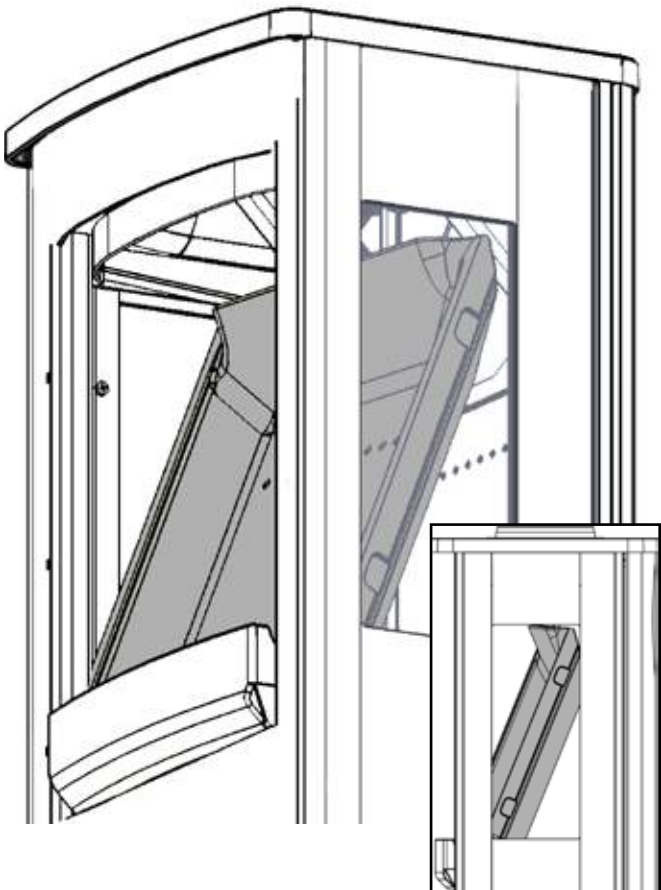

FIG 19

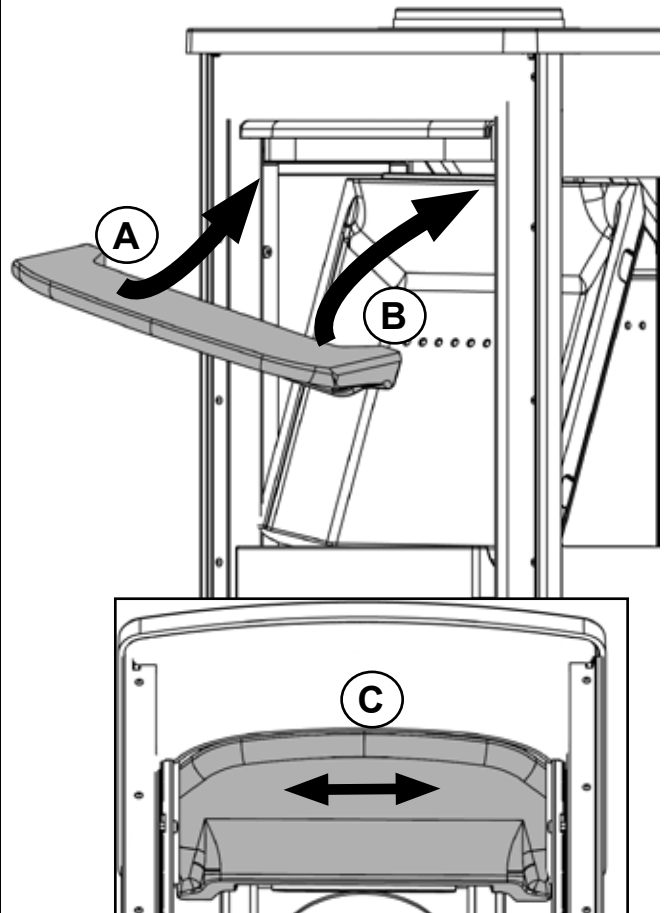

FIG 20

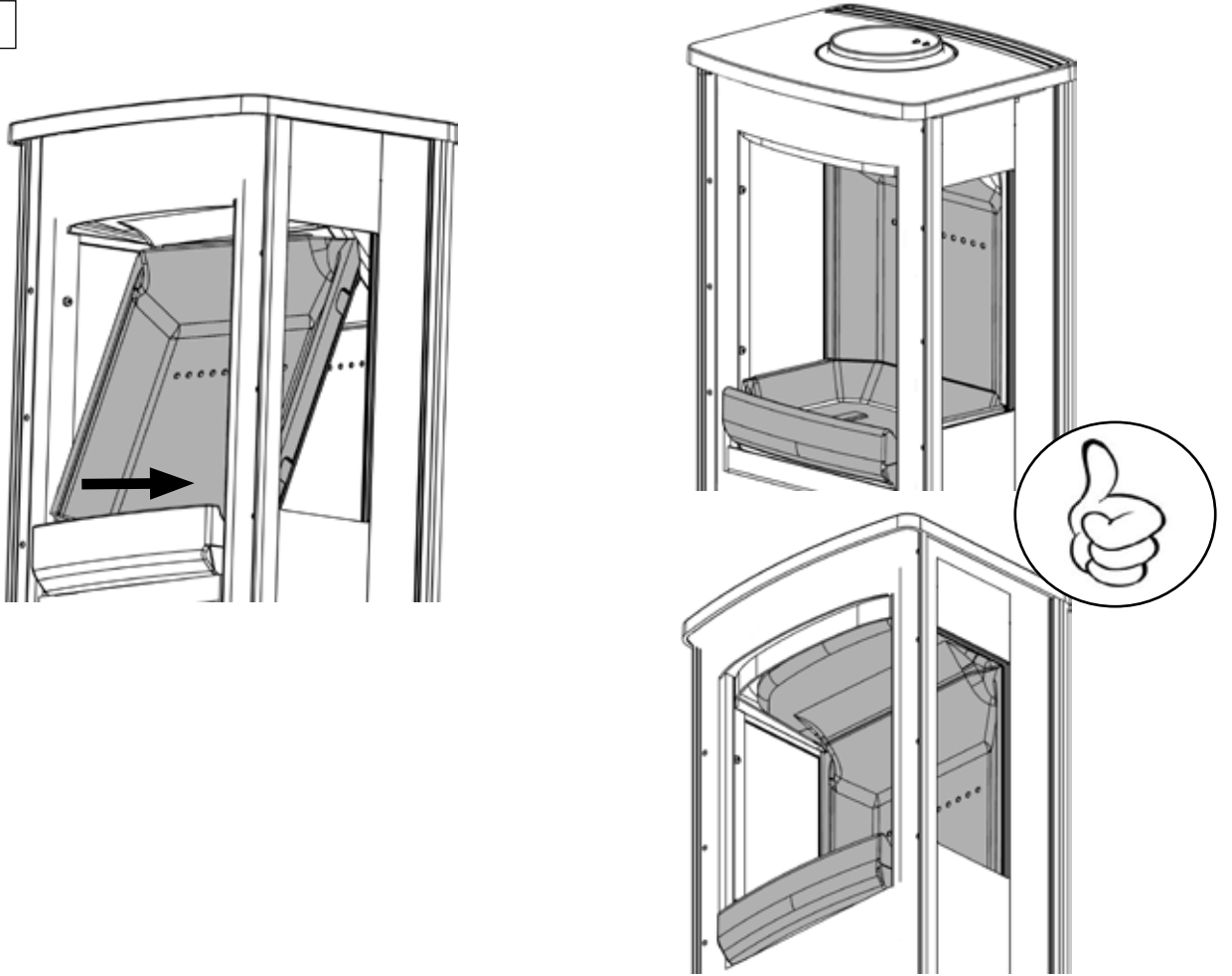

FIG 21

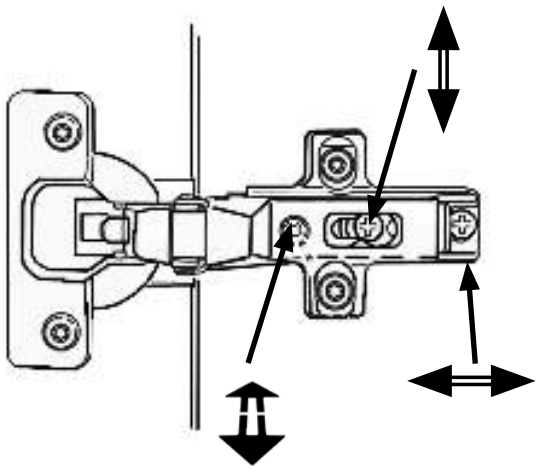
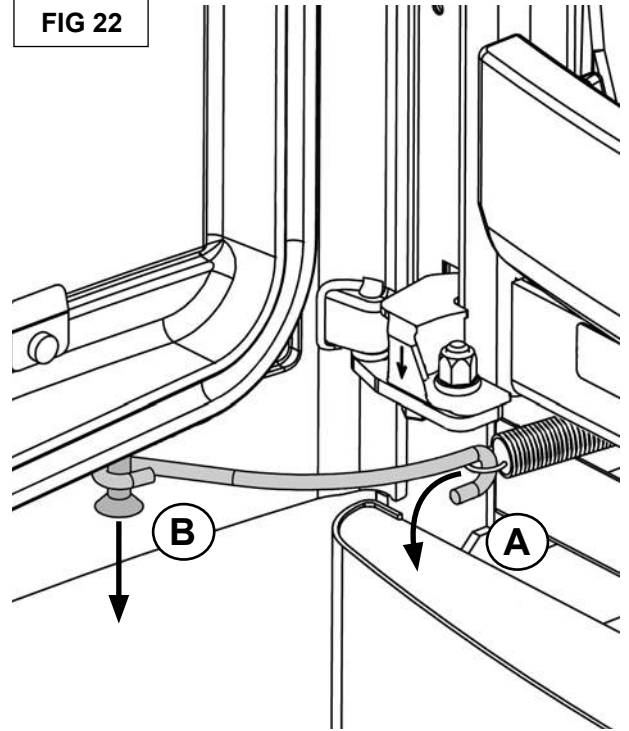

FIG 22



**Nordpeis**

Nordpeis AS, Gjellebekkstubben 11, N-3420 LIERSKOGEN, Norway
www.nordpeis.no