



Fire Your Imagination

Studio Slimline Range

Balanced Flue - Stone Chippings and Log

with Thermostatic Remote Control



IMPORTANT:
FOR EASY TO FOLLOW,
STEP BY STEP VIDEO
INSTRUCTIONS ON HOW TO
OPERATE AND MAINTAIN YOUR
GAZCO REMOTE SYSTEM GO TO
WWW.GAZCO.TV

Instructions for Use, Installation & Servicing

For use in GB & IE (Great Britain & Republic of Ireland).

IMPORTANT

THE OUTER CASING, FRONT AND GLASS PANEL BECOME EXTREMELY HOT DURING OPERATION AND WILL RESULT IN SERIOUS INJURY AND BURNS IF TOUCHED. IT IS THEREFORE RECOMMENDED THAT A FIREGUARD COMPLYING WITH BS 8423:2002 IS USED IN THE PRESENCE OF YOUNG CHILDREN, THE ELDERLY OR INFIRM.

This product contains a heat resistant glass panel. This panel should be checked during Installation and at each servicing interval. If any damage is observed on the front face of the glass panel (scratches, scores, cracks or other surface defects), the glass panel must be replaced and the appliance must not be used until a replacement is installed. Under no circumstances should the appliance be used if any damage is observed, the glass panel is removed or broken.

These Instructions must be left with the appliance for future reference and for consultation when servicing the appliance. Please make the customer aware of the correct operation of the appliance before leaving these instructions with them.

The commissioning sheet found on Page 3 of this Instruction manual must be completed by the Installer prior to leaving the premises.

Contents

Studio Slimline Balanced Flue

Covering the following models:

Model		Studio 1 Slimline	Studio 2 Slimline
Log Effect	Natural Gas	123-191	123-056
	LPG	123-489	-
White Stone Effect	Natural Gas	123-238	123-004
	LPG	123-642	-

Appliance Commissioning Checklist3

User Instructions4

Installation Instructions13

Technical Specifications 13

Site Requirements 16

Installation 19

Commissioning37

Servicing Instructions.....38

Fault Finding..... 38

How To Replace Parts..... 40

Basic Spare Parts List..... 47

Service Records52



If you have purchased your stove or fire from an authorised stockist within our Expert Retailer Network, then automatically your product will carry a 2 year warranty as standard. The 2 year warranty can be further extended to a total warranty period of 5 years by registering your Gazco Stove or Fireplace within one month of the latter of the purchase date or installation date. Accordingly, the start date for the warranty period is the date of purchase. During the registration process, the Expert Retailer details will be required for your Extended Warranty to be activated. Any product purchased outside of our Expert Retailer Network will carry a standard 12 month, non-extendable warranty.

It is a condition of the Extended Warranty that the installation complies with the relevant Building Regulations and is carried out by a suitably trained and qualified individual (GasSafe in the UK or equivalent in other countries) with the certificate of installation and the Commissioning Report on Page 3 completed and retained by the end user.

Full terms and conditions are detailed in the Warranty Statement on the Gazco website www.gazco.com. In the event of any conflict of information the wording on the website shall prevail.

Important Note: Should any problems be experienced with your product, claims must first be submitted to the Expert Retailer where the appliance was purchased from who will offer immediate assistance or contact Gazco on your behalf.



It is a requirement of the Building Regulations 2010 that the installation of this appliance is notified to the Local Authority. It is the responsibility of the GasSafe registered installer to carry out this notification to the Local Authority via the GasSafe register Competent Persons Scheme in England and Wales (different rules apply in Scotland and Northern Ireland).

When the installation has been notified, GasSafe will send a Building Regulations Compliance Certificate to you containing details of the work completed. Please ensure that the person responsible for the installation of this appliance completes this notification and records it in the Appliance Commissioning Checklist on page 3.

IT IS YOUR RESPONSIBILITY TO COMPLY WITH THE BUILDING REGULATIONS AND BE ABLE TO PRODUCE THIS CERTIFICATE SHOULD IT BE REQUIRED IN THE FUTURE.

Appliance Commissioning Checklist

To assist us in any guarantee claim please complete the following information:-

IMPORTANT NOTICE

Explain the operation of the appliance to the end user, hand the completed instructions to them for safe keeping, as the information will be required when making any guaranteed claims.

FLUE CHECK	PASS	FAIL
1. Flue Is correct for appliance		
2. Flue flow Test N/A		
3. Spillage Test N/A		
GAS CHECK	PASS	FAIL
1. Gas soundness & let by test		
2. Standing gas pressure	mb	
3. Appliance working pressure (on High Setting) NB All other gas appliances must be operating on full	mb	
4. Gas rate	m ³ /h	
5. Does Ventilation meet appliance requirements N/A		
BUILDING CONTROL NOTIFICATION	YES	NO
1. Installer notified GasSafe/Local Authority of installation via Competent Persons Scheme?		

RETAILER AND INSTALLER INFORMATION

Retailer	Installation Company
.....
.....
Contact No.	Engineer
.....
Date of Purchase	Contact No.
.....
Model No.	Gas Safe Reg No.
.....
Serial No.	Date of Installation
.....
Gas Type	

User Instructions

Welcome

Congratulations on purchasing your Studio fire, if installed correctly Gazco hope it will give you many years of warmth and pleasure for which it was designed.

The purpose of this manual is to familiarise you with your appliance, and give guidelines for its installation, operation and maintenance. If, after reading, you need further information, please do not hesitate to contact your Gazco retailer.

WARNING



In the event of a gas escape or if you can smell gas, please take the following steps:

- **Immediately turn off the gas supply at the meter/emergency control valve**
- **Extinguish all sources of ignition**
- **Do not smoke**
- **Do not operate any electrical light or power switches (On or Off)**
- **Ventilate the building(s) by opening doors and windows**
- **Ensure access to the premises can be made**

Please report the incident immediately to the National Gas Emergency Service Call Centre on 0800 111 999 (England, Scotland and Wales) , 0800 002 001 (N. Ireland) or in the case of LPG, the gas supplier whose details can be found on the bulk storage vessel or cylinder.

The gas supply must not be used until remedial action has been taken to correct the defect and the installation has been recommissioned by a competent person.

1. General

- 1.1 Installation and servicing must only be carried out by a competent person whose name appears on the Gas Safe register. To ensure the engineer is registered with Gas Safe they should possess an ID Card carrying the following logo:



- 1.2 In all correspondence, please quote the appliance type and serial number, which can be found on the data badge located on a plate under the Main Burner.

- 1.3 **Do not** place curtains above the appliance: You must have 300mm (1') clearance between the appliance and any curtains at either side.
- 1.4 No furnishings or other objects should be placed within 1 metre of the front of the appliance.
- 1.5 If a shelf is fitted, a distance of 400mm above the appliance is required.
- 1.6 If any cracks appear in the glass panel do not use the appliance until the panel has been replaced.
- 1.7 Do not obstruct the flue terminal in any way, i.e. by planting flowers, trees, shrubs etc. in the near vicinity, or by leaning objects against the terminal guard.
- 1.8 Do not put any objects on the terminal guard; it will lose its shape.
- 1.9 If you use a garden sprinkler, do not let quantities of water into the flue terminal.
- 1.10 This product is guaranteed for 5 years from the date of installation, as set out in the terms and conditions of sale between Gazco and your local Gazco retailer. Please consult with your local Gazco retailer if you have any questions. In all correspondence always quote the Model Number and Serial Number.



IMPORTANT: NEVER position a television or screen above this appliance.

2. Operating the Appliance

The appliance is operated by thermostatic remote control.

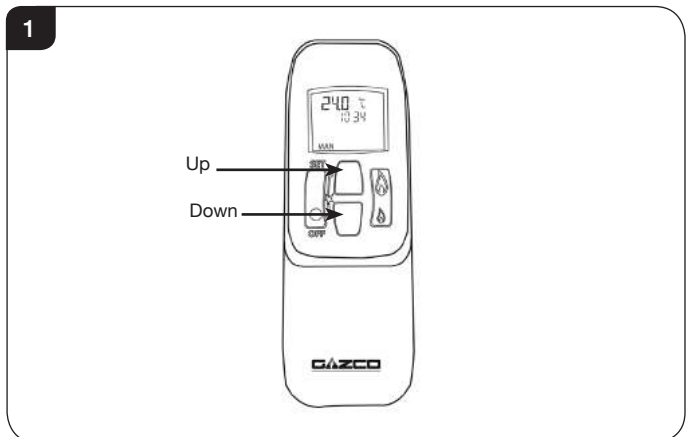

- 2.1 **Turning the appliance On**
Your remote can control the gas fire from pilot ignition through to shut down.
- To turn the fire on press the OFF button and the UP button simultaneously. You hear several short signals.
The pilot and main burner ignite and the remote is now in Manual Mode:

User Instructions

i **IMPORTANT: YELLOW FLAMES TYPICALLY APPEAR WHEN THE APPLIANCE HAS REACHED NORMAL OPERATING TEMPERATURE. THIS CAN TAKE UP TO 30 MINUTES.**

! **WARNING: IF THE APPLIANCE FAILS TO LIGHT OR BECOMES EXTINGUISHED IN USE, WAIT 3 MINUTES BEFORE ATTEMPTING TO RELIGHT.**

2.2 There are 3 different modes available for controlling and operating the appliance:

1. Manual Mode
2. Temp Mode (Automatic)
3. Timer Mode (Automatic)

2.3 In **MANUAL MODE** you can:

- turn on the main burner using the UP button.
- regulate the flame from high to low and back.
- turn off the burner leaving just the pilot burning.

In **TEMP MODE (Automatic)** you can:

- set the room temperature so the thermostat in the remote automatically maintains that temperature.

In **TIMER MODE (Automatic)** the fire:

- turns on and off according to the set time periods.
- automatically regulates the room temperature during the set periods.

i **NOTE: When operating the fire in Temp or Timer mode, the pilot remains lit and the fire then automatically switches on at programmed times to bring the room to the set temperature whether or not you are in the room. NEVER LEAVE ANY COMBUSTIBLE MATERIALS WITHIN 1 METRE OF THE FRONT OF THE APPLIANCE.**

Switching Between Modes

2.4 Press the SET button to change to Temperature Mode. Press again to change to Timer Mode. Keep pressing to run through all operating modes. These are:

- MAN
- DAY TEMP
- NIGHT TEMP
- TIMER
- and back to MAN

NOTE: MAN mode can also be reached by pressing either the UP or DOWN button.

Manual Mode

2.5 Press the OFF button and the UP button simultaneously. You hear several clicks and audible beeps as the fire begins the ignition process, (up to 30 seconds).

Turning the appliance Off:

Press the OFF button to turn the appliance off.

FOR SAFETY, YOU MUST WAIT 30 SECONDS BEFORE LIGHTING THE FIRE AGAIN.

Increasing the Flame Height:

Press the UP button once to increase flame height one stage. Press and hold the UP button to increase to maximum.

Decreasing the Flame Height:

Press the DOWN button once to decrease flame height one stage. Press and hold the DOWN button to decrease to minimum. At the lowest point the fire goes to 'Standby Mode' (Only Pilot lit).

i **NOTE: While pressing a button a symbol indicating transmission appears on the display. The receiver confirms transmission with a sound signal.**

Temp Mode (Automatic)

2.6 The display shows the current **room** temperature.

To increase or decrease the fire's output:

Press the SET button to select either the DAY TEMP or the NIGHT TEMP mode by briefly pressing the SET button.

Hold the SET button until the TEMP display flashes and then let go.

Set the desired temperature with the UP and DOWN arrows. (Minimum temperature 5C, maximum 40C or 40F to 99F when Fahrenheit is the preferred option)

Press the OFF button to stop the display flashing or wait to return to TEMP mode.

i **NOTE: If you set a temperature that is beneath the current room temperature, the fire automatically switches to PILOT (Stand by).**

If you would like the Night temperature control to turn off then decrease the temperature until [--] is displayed.

Timer Mode (Automatic)

2.7 There are two programmable settings you can make over a 24 hour period, P1 and P2. These are normally used to provide an early morning and evening setting for each working week:

- P1 + ● = Start Timed Setting 1
- P1 + ☺ = End of Timed Setting 1
- P2 + ● = Start Timed Setting 2
- P2 + ☺ = End of Timed Setting 2

User Instructions

2.8 P1 - Program 1 for a Timed Setting

Press the SET button until the TIMER mode is displayed.

Hold the SET button. The display flashes the current time for P1. **While the time displayed is flashing you can alter the hours and minutes set.**

To set the time your fire first lights, change P1 ●

- Press the UP button to alter the hour.
- Press the DOWN button to alter the minutes in 10 minute increments.

Press SET again to move to the end setting for P1 ➔ This is the time your Studio first shuts down:

- Press the UP button to alter the hour.
- Press the DOWN button to alter the minutes.

2.9 P2 - Program 2 for a Timed Setting

Use the same steps outlined in 2.8 to change the setting for P2.
If you have already set P1 and want to alter the setting for P2 only:

- Press the SET button until TIMER mode is displayed.
- Hold the SET button **until the display flashes the current time** for P1 ● .
- Press the SET button once again to scroll past the settings for P1 ● and P1.

With the time still flashing:

- Press the UP button to alter the hour.
- Press the DOWN button to alter the minutes.

Once all four times are set press the OFF button.

2.10 To view existing settings:

- Select Timer Mode.
- Press and briefly hold the SET button you see the start time for P1.
- Repeat the above step for the start and end of each program.

Low Battery

"BATT" is displayed on the remote when its batteries need replacement.

Setting the time

Simultaneously press the up and down buttons.

Press the up button to set the hour and the down button to set the minutes.

Press OFF to return to the manual mode or simply wait.

Setting the °C/24 Hour or °F/12 Hour clock

Press OFF and the down arrow until the display changes from °C/24 hour clock to °F/12 hour clock and vice versa.

i If the remote is removed, lost or damaged, signals transmitted to the receiver cease. Your fire will go to standby (pilot) mode after 6 hours.

3. Changing the Appliance Batteries

The appliance batteries are located behind the wall plate.

- 3.1 Undo the two screws securing the wall plate and remove, see Diagram 2.

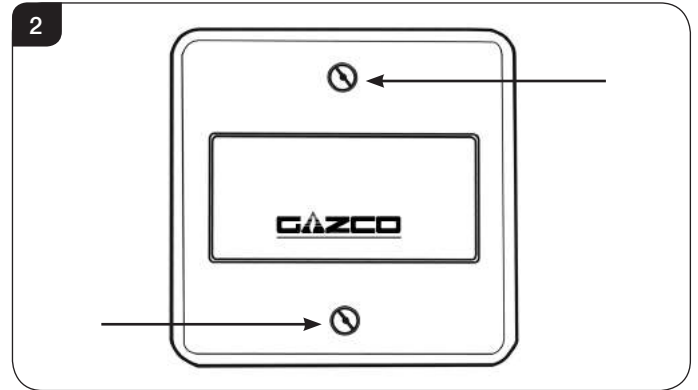

- 3.2 Unclip the battery holder from the wall plate and remove the old batteries.
- 3.3 Correctly position the four new AA size batteries into the battery holder. Re-assemble the battery holder as shown in Diagram 3.

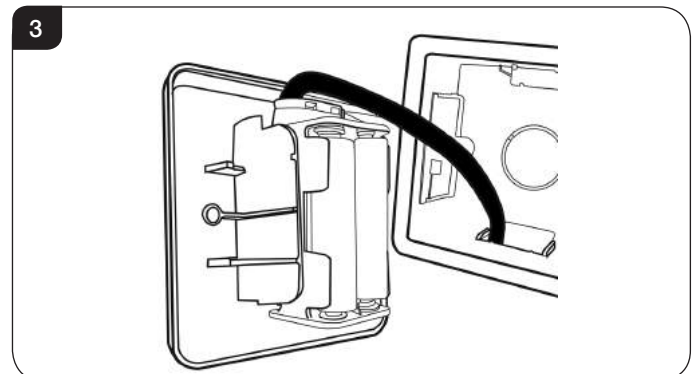

! PLEASE ENSURE NO WIRES ARE TRAPPED BEFORE REPLACING THE WALL PLATE. THE TOUCH PAD LEAD IS EASILY DAMAGED.

User Instructions

4. Cleaning the Appliance

4.1 Make sure the appliance and surrounds are cool before cleaning.

4.2 Use:

- A dry cloth or stainless steel product to clean the polished plate.
- A damp cloth for the painted frame.
- A damp cloth to clean the granite/enamelled inner panels.
- Soap and water to clean the glass.

Opening the Glass Window:

4.3 **Steel, Verve or Glass Frame**

If fitted with a Steel, Verve or Glass Frame, this needs to be removed first:

4.4 Lift the frame upwards off its four support brackets, see Diagram 4.

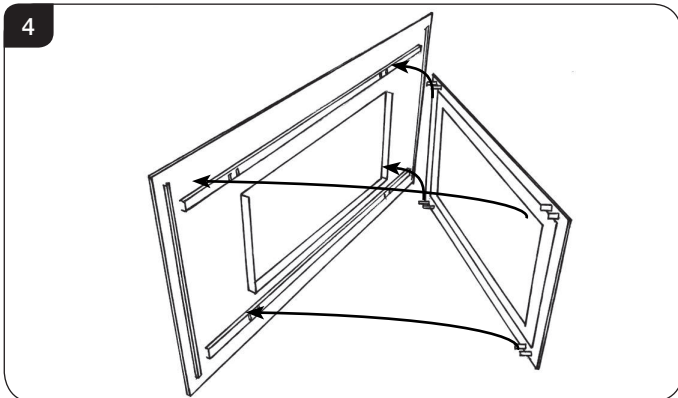

All models

4.5 Using the hexagon key provided release the window locks at the top of the glass door, see Diagram 5.

4.6 The locks move from shut to open towards the outer edges of the glass door, see Diagram 5.

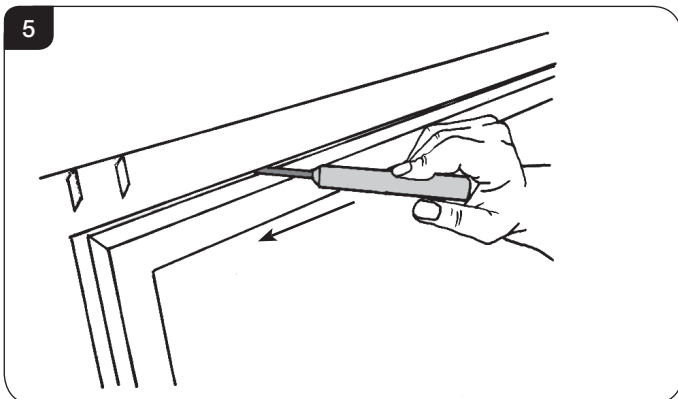

4.7 Support the frame and let it fall gently forward.

4.8 Open it down to its natural stop position. Note the door does not open flat.

4.9 **When closing the window ensure the window catches are fully engaged.**



UNDER NO CIRCUMSTANCES SHOULD THE APPLIANCE BE USED WITHOUT THE CATCHES HOLDING THE DOOR IN PLACE.

5. Arrangement of the fuel bed

Advice on handling and disposal of fire ceramics



The fuel effect and liners of this appliance are made from Refractory Ceramic Fibre (RCF), a material which is commonly used for this application.

Protective clothing is not required when handling these articles, but we recommend you follow normal hygiene rules of not smoking, eating or drinking in the work area and always wash your hands before eating or drinking.

To ensure that the release of RCF fibres are kept to a minimum, during installation and servicing a HEPA filtered vacuum is recommended to remove any dust accumulated in and around the appliance before and after working on it. When servicing the appliance it is recommended that the replaced items are not broken up, but are sealed within heavy duty polythene bags and labelled as RCF waste.

RCF waste is classed as stable, non-reactive hazardous waste and may be disposed of at a licensed landfill site.

Excessive exposure to these materials may cause temporary irritation to eyes, skin and respiratory tract; wash hands thoroughly after handling the material.

User Instructions

6. Log Layout

LOGS MUST BE POSITIONED ACCORDING TO THE FOLLOWING INSTRUCTIONS TO GIVE THE CORRECT FLAME EFFECT

Studio 1 Layout

- 6.1 Ensure the burner tray is clean and free from any debris.
- 6.2 All logs can be identified by a letter (A - D) on their underside.

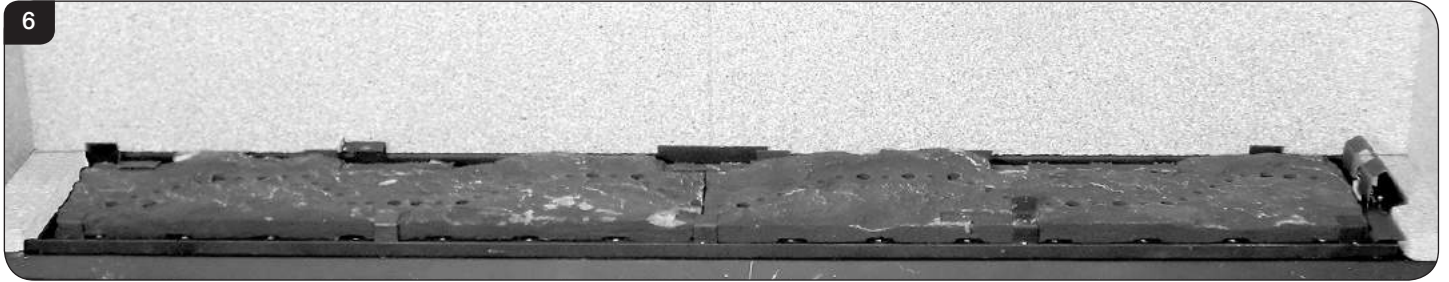

- 6.3 Position Log A between the two tabs at the back of the burner tray, see Diagram 7. The left hand side should rest on the tab at the back of the burner tray and be pushed up to the supporting lip, see Diagram 7 Detail.

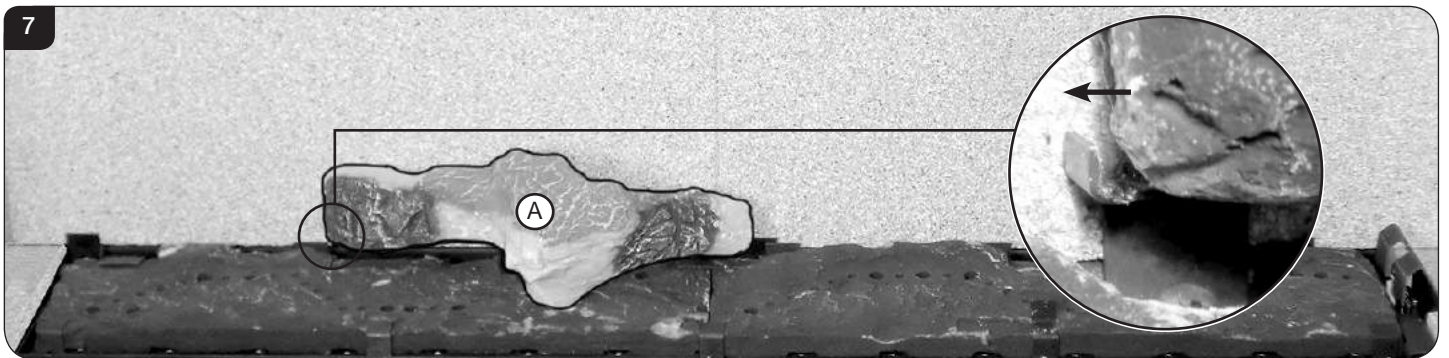

- 6.4 Place the left hand end of Log B against the back right tab on the burner tray, see Diagram 8. Ensure that the front branch is in line with the front of the burner tray.

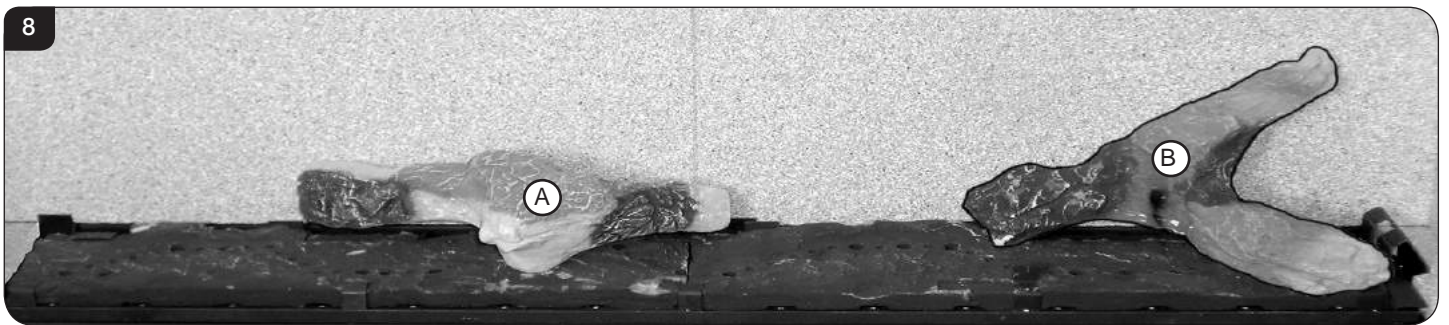

- 6.5 Rest the left end of Log C on the bottom left vermiculite panel in the back left corner, see Diagram 9. The right end of Log C rests across Log A with the small front branch resting on the burner tray.

User Instructions

- 6.6 Engage the left hand end of Log D with the right hand end of Log A.
The right hand end of Log D fits in front of the metal stop on the front of the burner tray.

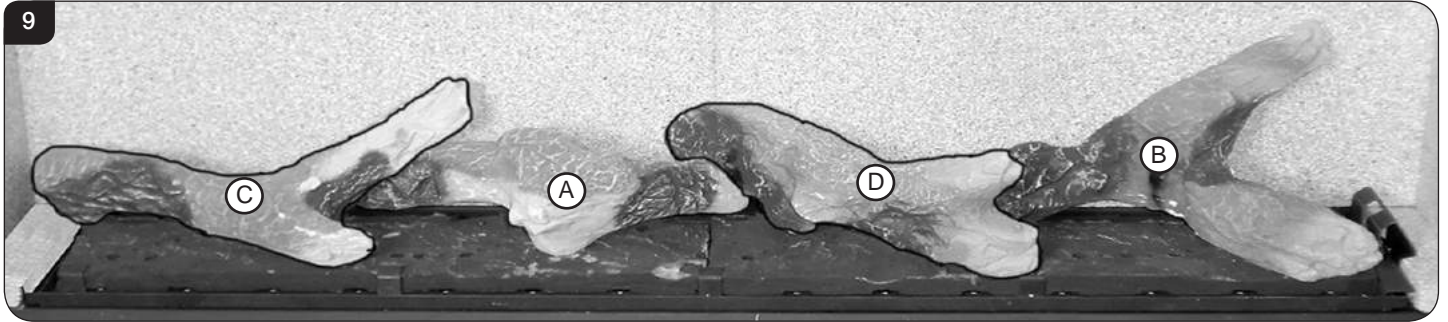

- 6.7 Separate the Embaglow material into smaller pieces and pull into shape to create a fine layer.
6.8 Place the pieces of Embaglow between the logs in the highlighted areas shown in Diagram 10. Ensure the material is placed loosely between the logs to create a random glow.

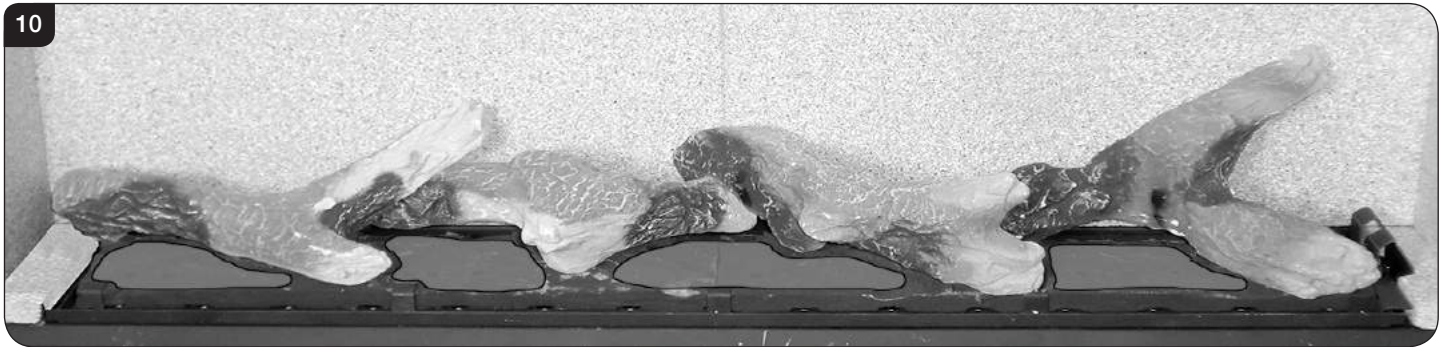

Studio 2 Layout

- 6.9 Ensure the burner tray is clean and free from any debris.
6.10 All logs can be identified by a letter (A, B, C, 2 x D, E) on their underside.

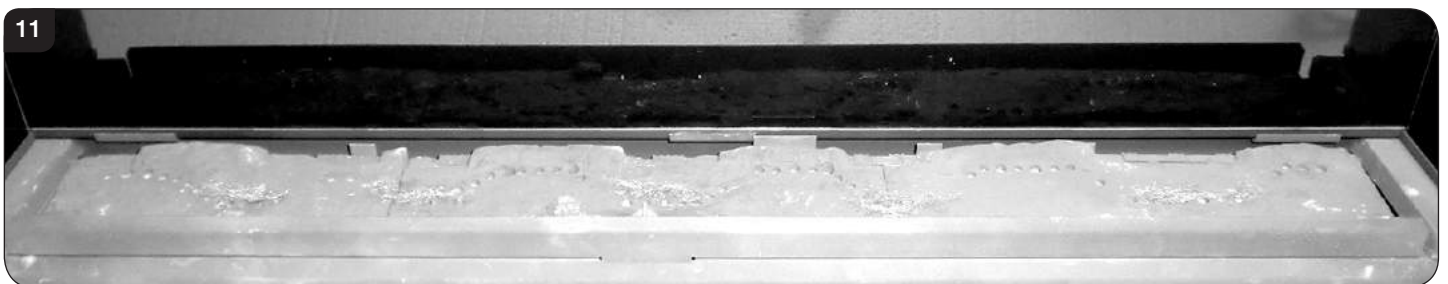

- 6.11 Position Log A between the two tabs at the back of the burner tray, see Diagram 12. Ensure that it is pushed up against the back panel and the end of Log A is on the raised section of the burner.

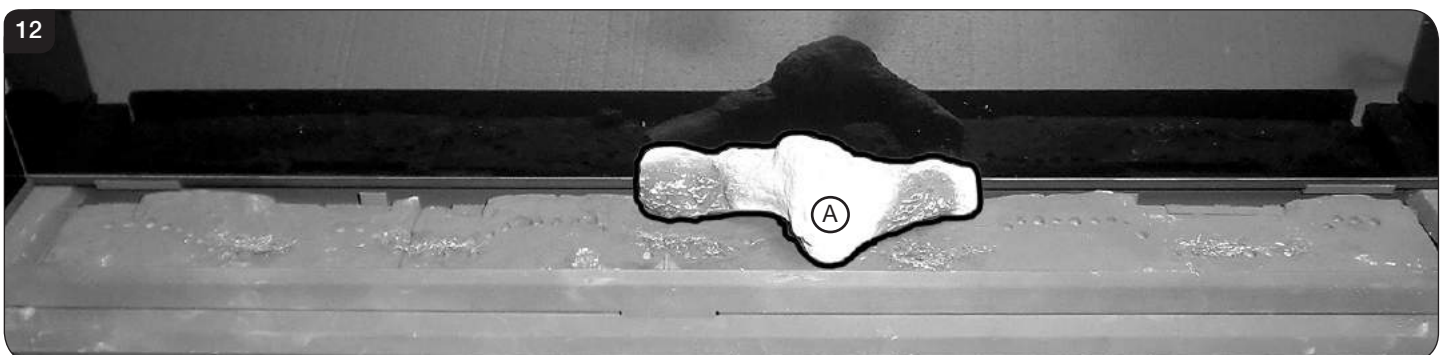

User Instructions

- 6.12 Place the left hand end of Log B against the back right tab on the burner tray, see Diagram 13. Ensure that the front branch is in line with the front of the burner tray.

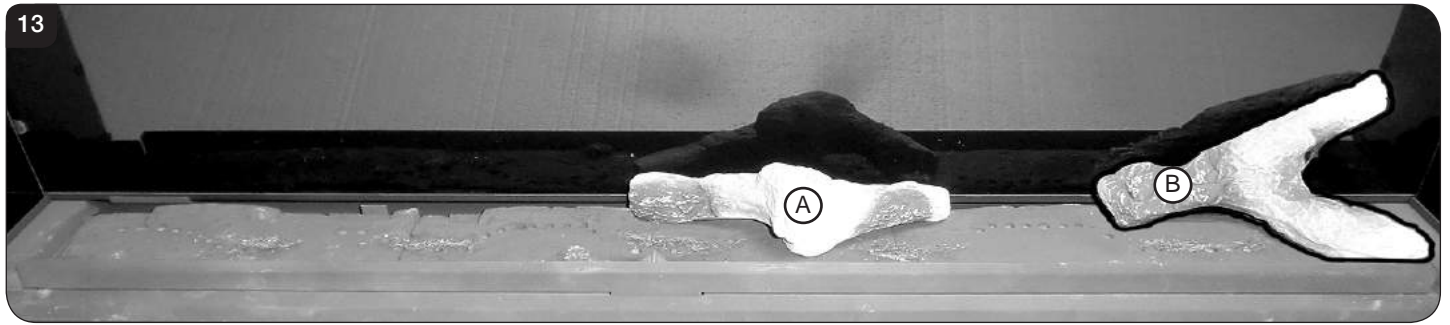

- 6.13 Rest the left end of Log D on the bottom left vermiculite panel in the back left corner, see Diagram 14. The right end of Log D should be touching the rear liner.

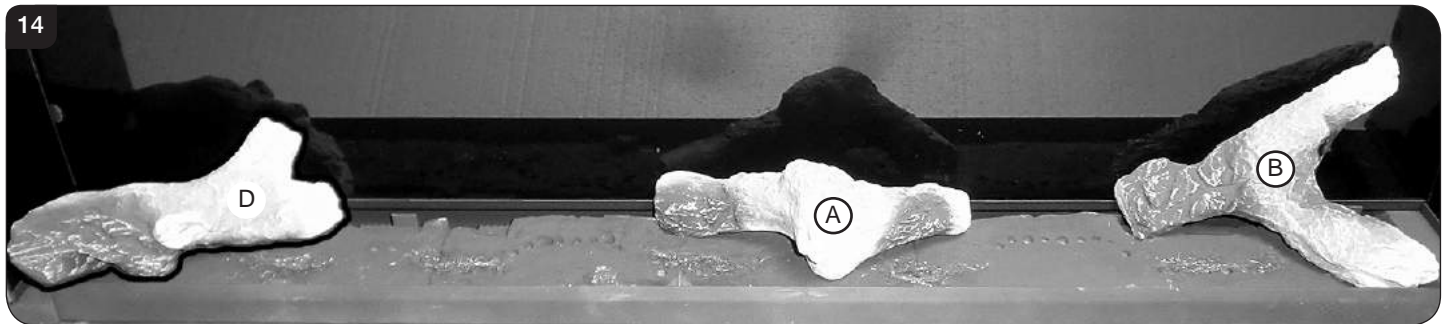

- 6.14 Engage the left hand end of Log D with the right hand end of Log A. The right hand end of Log D fits in front of the metal stop on the front of the burner tray.

- 6.15 Place the left hand side of Log C to the rear of the burner tray against the tab and the right hand side at the front of the burner with the rear section resting on Log A.

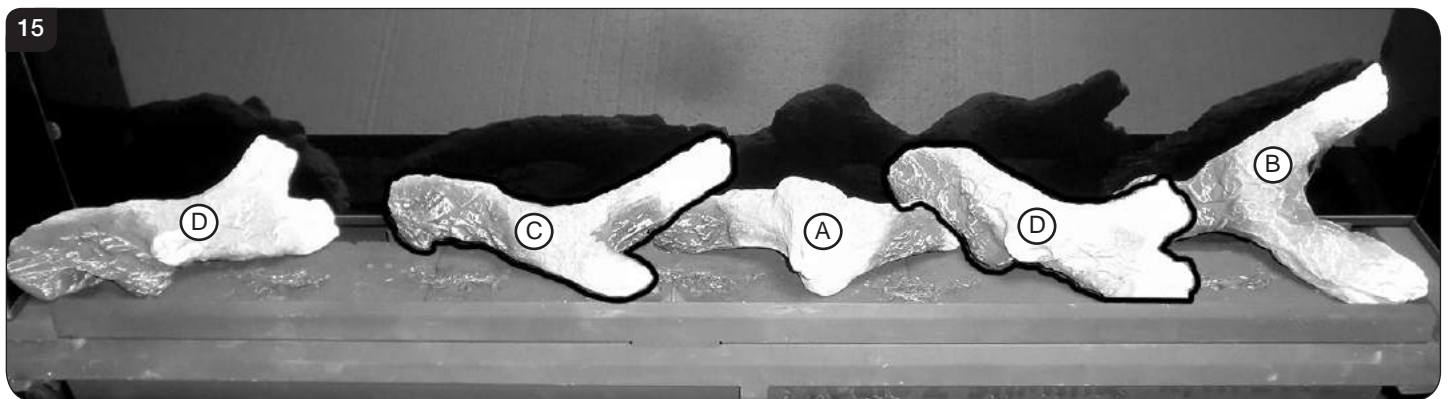

- 6.16 Log E rests against logs C and D with the lower end located in the cutout in the burner, see Diagram 16.

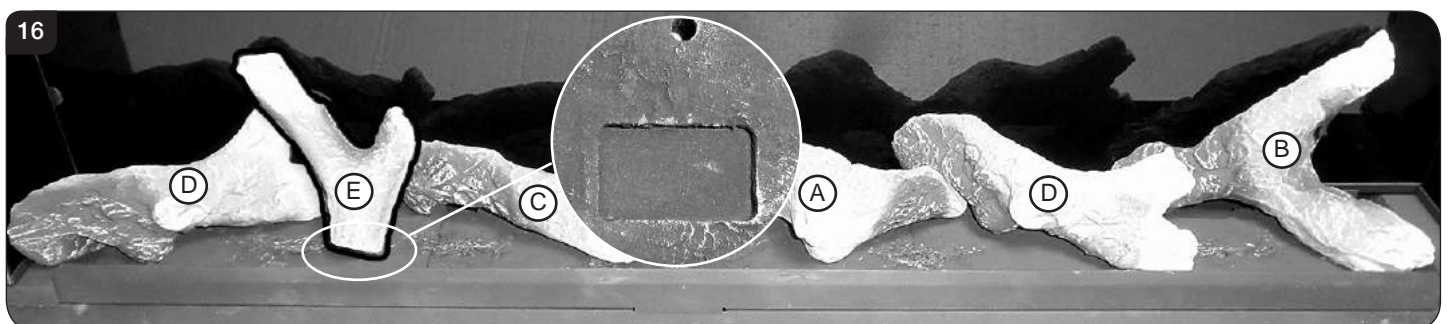

User Instructions

- 6.17 Separate the Embaglow material into smaller pieces and pull into shape to create a fine layer.
- 6.18 Place the pieces of Embaglow between the logs in the highlighted areas shown in Diagram 17. Ensure the material is placed loosely between the logs to create a random glow.
IMPORTANT EMBAGLOW MUST BE KEPT AWAY FROM THE PILOT.

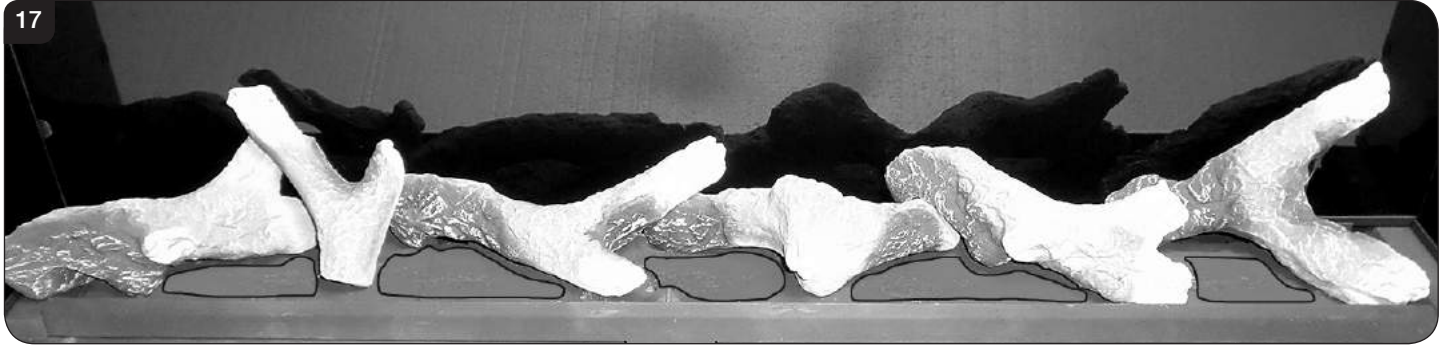

7. Stone/ Glass Fuel Effect Layout

- 7.1 To use the white stone or glass granule fuel effect, apply according to the following instructions to give the correct flame effect.
- 7.2 Ensure the burner tray is clean and free from any debris, see Diagram 18.

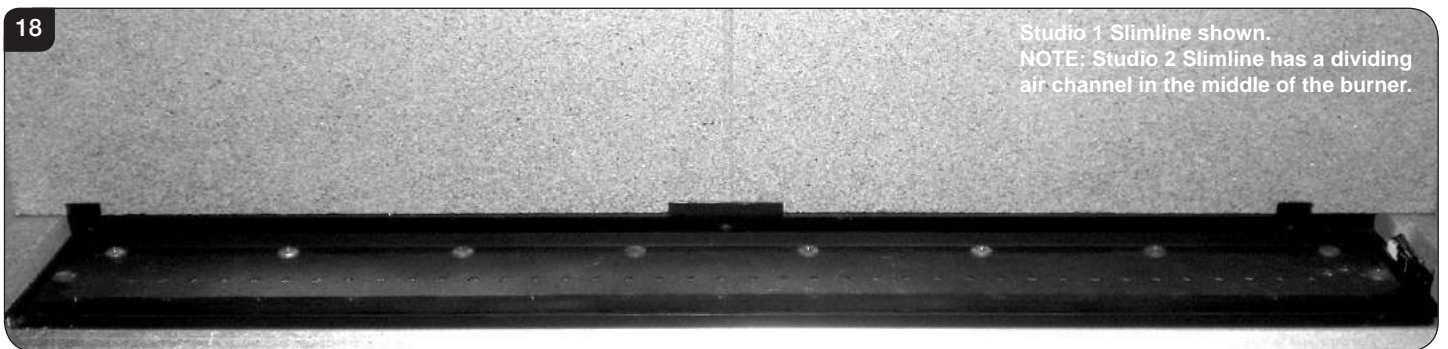

- 7.3 Fill the tray making sure the effect is flattened so it is level with the rim of the tray. **DO NOT OVERFILL THE BURNER TRAY.**
TAKE CARE NOT TO SPILL EFFECT INTO THE PILOT AREA FRONT CHANNEL OR GAP AT REAR OF TRAY (ALL MODELS) AND THE DIVIDING AIR CHANNEL (STUDIO 2 ONLY) see Diagram 19 & 20.
ONLY GENUINE GAZCO PARTS CAN BE USED IN THIS APPLIANCE.

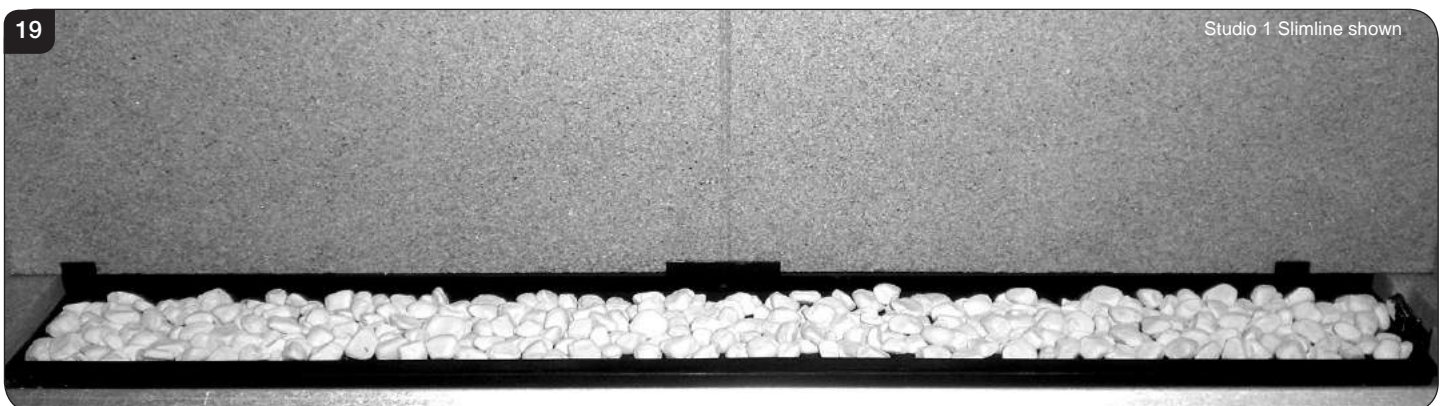

User Instructions



8. Flame Failure Device

- 8.1 This is a safety feature incorporated on this appliance which automatically switches off the gas supply if the pilot goes out and fails to heat the thermocouple.

IF THIS OCCURS DO NOT ATTEMPT TO RELIGHT THE APPLIANCE FOR 3 MINUTES.

9. Running In

- 9.1 During initial use of a new GAZCO appliance a strong odour will be encountered as various surface coatings become hot for the first time. Although these odours are harmless it is recommended that the appliance is operated on maximum for 4 to 8 hours in order to fully burn off these coatings. After this period the odours should then disappear.

If the odours persists, please contact your installer for advice.

- 9.2 During the first few hours of burning there may be discolouration of the flames. This will also disappear after a short period of use.

10. Servicing

- 10.1 The appliance must be serviced every 12 months by a qualified Gas Engineer. In all correspondence always quote the Model number and the Serial number which may be found on the Commissioning Checklist (Page 3).

11. Ventilation

- 11.1 This appliance requires no additional ventilation.

12. Installation Details

- 12.1 Your installer should have completed the commissioning sheet at the front of this book. This records the essential installation details of the appliance. In all correspondence always quote the Model number and Serial number.

13. Hot Surfaces

- 13.1 Parts of this appliance become hot during normal use.
13.2 Regard all parts of the appliance as a working surface.
13.3 Provide a suitable fire guard to protect young children and the infirm.

14. Appliance will not light

If you cannot light the appliance:

- 14.1 Check and change the batteries in the remote handset.
14.2 Check and change the wall plate batteries (see Section 3).
14.3 Consult your Gazco retailer or installer if the Studio still does not light.

Installation Instructions

Technical Specification

Covering the following models:

Model		Studio 1 Slimline	Studio 2 Slimline
Log Effect	Natural Gas	123-191	123-056
	LPG	123-489	-
White Stone Effect	Natural Gas	123-238	123-004
	LPG	123-642	-

Model	Gas CAT.	Gas Type	Working Pressure	Aeration	Injector	Gas Rate m ³ /h	Input kW (Gross)		Country
							High	Low	
Studio Slimline 1 Log Effect	I ₂ H	Natural (G20)	20mbar	2 x 6.5mm	170	0.492	5.2	3.5	GB, IE
	I ₃ P	Propane (G31)	37mbar	2 x (25x15)	150	0.188	5.1	3.4	
Studio Slimline 1 Stone Effect	I ₂ H	Natural (G20)	20mbar	2 x 8mm	170	0.492	5.2	3.5	
	I ₃ P	Propane (G31)	37mbar	2 x (25x15)	150	0.188	5.1	3.4	
Studio Slimline 2 Log Effect	I ₂ H	Natural (G20)	20mbar	2 x 6.5mm	184	0.58	6.1	3.2	
Studio Slimline 2 Stone Effect	I ₂ H	Natural (G20)	20mbar	2 x 7mm	184	0.58	6.1	3.2	
Efficiency Class 1 - 82% / NO_x Class 4									
Flue Outlet Size Ø 100mm									
Flue Inlet Size Ø 150mm									
Gas Inlet Connection Size Ø 8mm									

i The net efficiency of this appliance has been measured as specified in EN613:2001 and the result after conversion to gross using the appropriate factor from Table E4 of SAP 2009 is 75%. The test data has been certified by Kiwa Nederland BV. The gross efficiency value may be used in the UK Government's Standard Assessment Procedure (SAP) for energy rating of dwellings.

Installation Instructions

Technical Specification

This appliance has been certified for use in countries other than those stated. To install this appliance in these countries, it is essential to obtain the translated instructions and in some cases the appliance will require modification. Contact Gazco for further information.

PACKING CHECKLIST

Qty Description	Fixing Kit containing:
For Stone Chippings Layout	1 x Instruction Manual
1 White Stone Chippings	6 x Wood Screws
1 Liner Set	6 x Wall Plugs
	1 x Handset
	4 x AA cell batteries
For Log Layout	1 x 9v cell batteries
1 Log Set	1 x Wall box
1 Liner Set	1 x Wall plate
1 Bag Embaglow material	1 x Battery holder

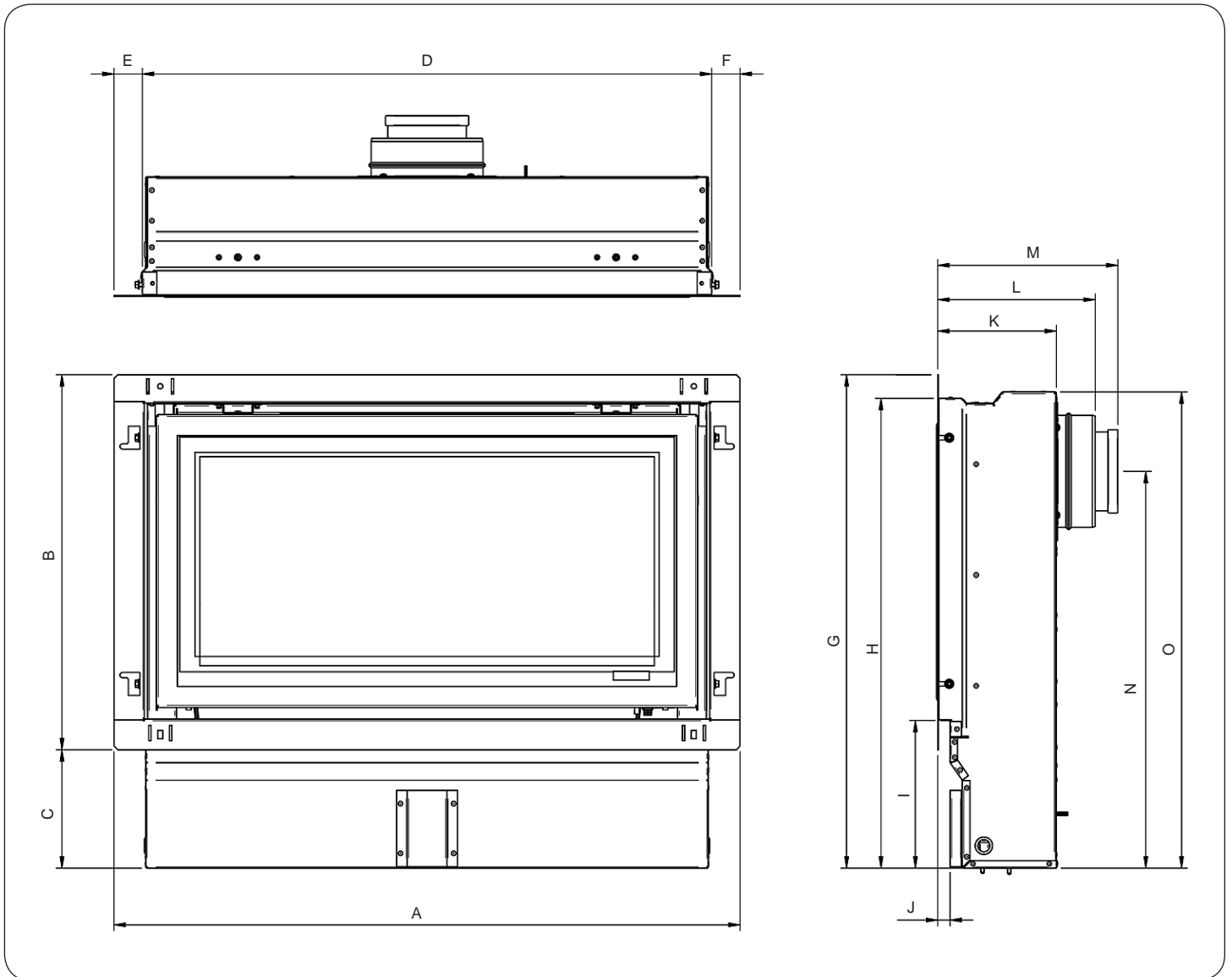

Model	A	B	C	D	E	F	G	H	I	J	K	L	M	N	O
Slimline 1	820	491	155	746	37	37	645	614	193	16	155	206	236	519	623
Slimline 2	1020	491	155	946	37	37	645	614	193	16	155	206	236	519	623

Installation Instructions

Technical Specification

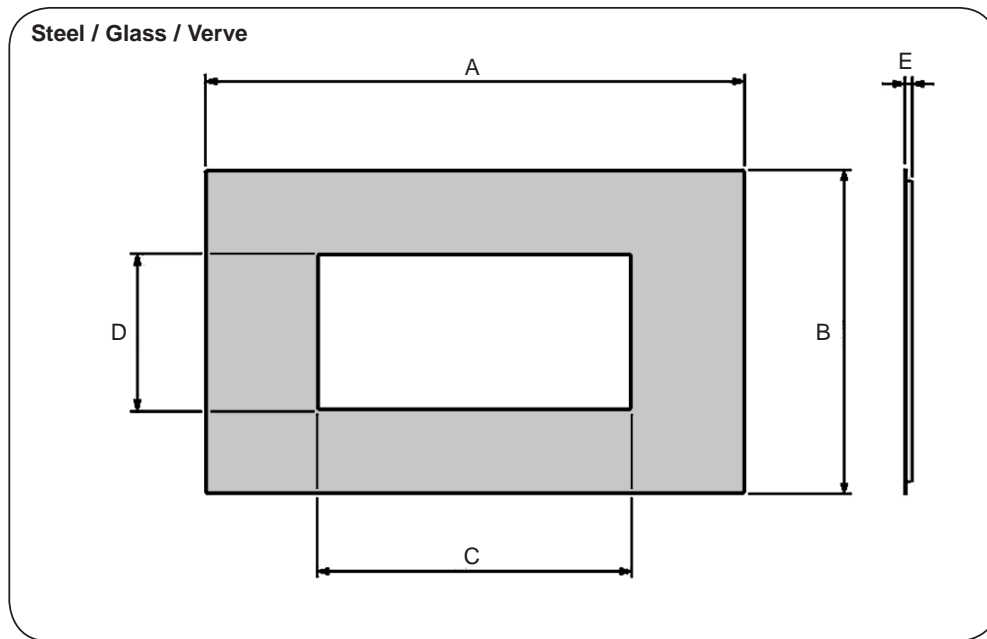

Steel / Glass / Verve Fronts

Front	A		B		C		D		E	
	Studio 1	Studio 2	Studio 1	Studio 2	Studio 1	Studio 2	Studio 1	Studio 2	Studio 1	Studio 2
Steel	1264	1500	528	528	646	846	320	320	27	27
Glass	1264	1500	528	528	650	852	324	324	29	29
Verve	1264	1500	528	528	650	850	324	324	53	53

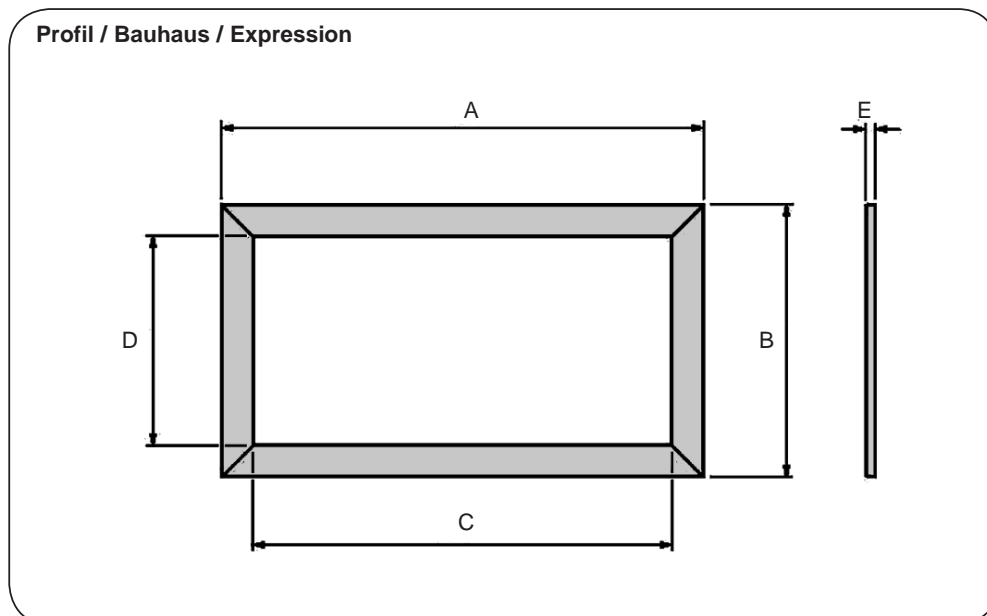

Profil / Bauhaus Expression Frames

Frame	A		B		C		D		E	
	Studio 1	Studio 2	Studio 1	Studio 2	Studio 1	Studio 2	Studio 1	Studio 2	Studio 1	Studio 2
Profil	836	1036	510	510	740	740	414	414	12.5	12.5
Bauhaus	850	1050	524	524	740	740	414	414	28	28
Expression	940	1140	614	614	740	740	414	414	40	40

Installation Instructions

Site Requirements

1. Flue & Chimney Requirements

Note: This appliance must only be installed with the flue supplied.

You must adhere to the following:

- 1.1 The flue must be sited in accordance with BS5440: Part 1 (latest edition), see Diagram 1.
- 1.2 Fit a guard to protect people from any terminal less than 2 metres above any access such as level ground, a balcony or above a flat roof.
- 1.3 All horizontal flues must be securely fixed and fire precautions followed in accordance with local and national codes of practice.
- 1.4 To measure for a horizontal terminal decide on the terminal position.

- 1.5 Measure the height from the top of the appliance to the centre of the required outlet.
- 1.6 For minimum and maximum flue dimensions see Section 2.
- 1.7 Support the opening of a masonry installation with a lintel.
- 1.8 Only the horizontal terminal section can be reduced in size.

1 UK Dimensions

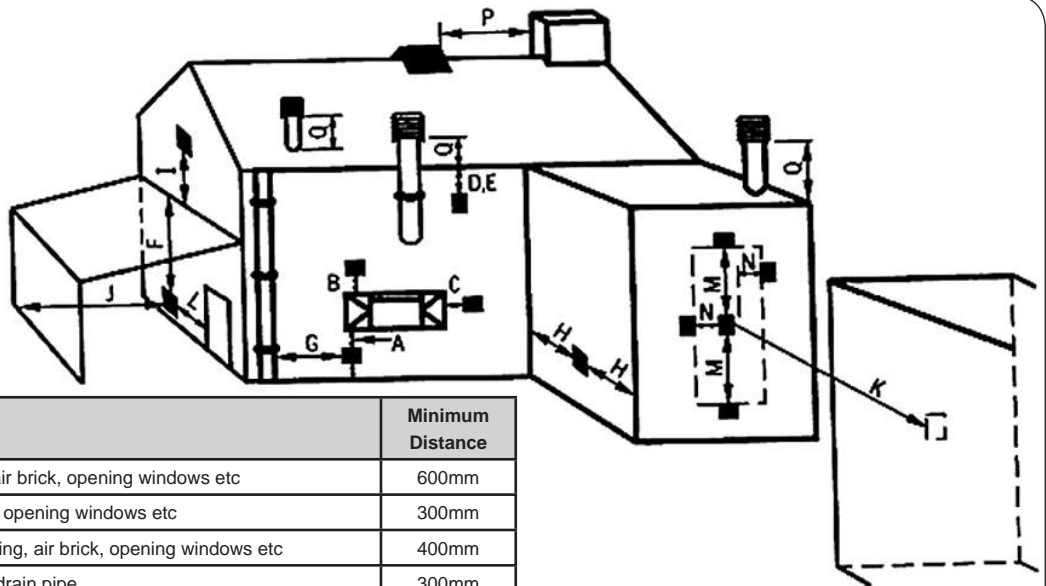

Dimension	Terminal Position	Minimum Distance
A	Directly below an opening, air brick, opening windows etc	600mm
B	Above an opening, air brick, opening windows etc	300mm
C	Horizontally next to an opening, air brick, opening windows etc	400mm
D	Below gutters, soil pipes or drain pipe	300mm
E	Below eaves	300mm
F	Below balcony or car port roof	600mm
G	From a vertical drain pipe or soil pipe	300mm
H	From an internal or external corner	600mm
I	Above group roof or balcony level	300mm
J	From a surface facing the terminal	600mm
K	From a terminal facing the terminal	600mm
L	From an opening in the car port (e.g. door, window) into the dwelling	1200mm
M	Vertically from a terminal on the same wall	1500mm
N	Horizontally from a terminal on the same wall	300mm
O	From the wall on which the terminal is mounted	N/A
P	From a vertical structure on the roof	600mm
Q	Above intersection with roof	300mm

* In addition, the terminal should not be nearer than 300mm to an opening in the building fabric formed for the purpose of accommodating a built-in element such as a window frame.

Installation Instructions

Site Requirements

2. Rear Flue

2

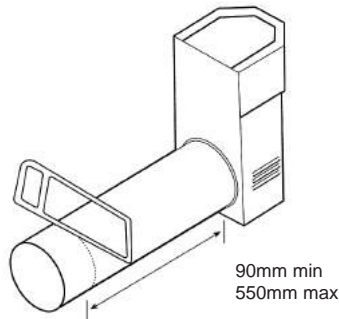

Terminal dimensions:
395 x 200 x 200 mm (H x W x D)
Guard supplied
Cut to length as required on site.

- 2.1 Decide on the terminal position.
- 2.2 Measure the height from the finished hearth level/ base of the appliance to the centre of the required hole.
- 2.3 A masonry installation requires the addition of a suitable lintel to support the opening. Refer to Installation Instructions, Technical Information for details of the flue length.

NOTE - Carefully consider:

- a) Terminal positions
- b) Flue supports
- c) Weatherproofing
- d) Fire precautions

For all the above options, you must conform to local and national codes of practice.

- 2.4 **Use only Gazco supplied flue on this appliance.**
- 2.5 **A guard (supplied) must be fitted to any terminal less than 2 metres above any access such as level ground, a balcony or above a flat roof.**

Timber Framed Buildings

- 2.6 It will be necessary to provide additional clearance when the flue passes through a wall containing any combustible materials so as to prevent a fire hazard.
- 2.7 The hole through which the flue will pass, must have a steel sleeve which is positioned so that an air gap of at least 25mm is maintained between the outer surface of the flue, and any part of the sleeve.
- 2.8 For further guidance on the installation of gas appliances in timber framed buildings, contact your local buildings control authority.

3. Gas Supply

THIS APPLIANCE IS INTENDED FOR USE ON A GAS INSTALLATION WITH A GOVERNED METER.

- 3.1 Before installation, ensure that the local distribution conditions (identification of the type of gas and pressure) and the adjustment of the appliance are compatible.
- 3.2 Ensure the gas supply delivers the required amount of gas and is in accordance with the rules in force.
- 3.3 Soft copper tubing can be used on the installation and soft soldered joints outside the appliance.
- 3.4 If it is intended to conceal the gas supply within the wall cavity, there must be no joints in any part of the supply that are not readily accessible when the appliance has been installed.
- 3.5 A factory fitted isolation device is part of the inlet connection; no further isolation device is required.
- 3.6 All supply gas pipes must be purged of any debris that may have entered prior to connection to the appliance.
- 3.7 The gas supply enters through the silicone panel located on the LEFT-HAND rear or base of the outer box. Slit with a sharp knife before passing the supply pipe through.
- 3.8 The gas supply must be installed in a way that does not restrict the removal of the appliance for servicing and inspection.
- 3.9 The supply pipe may be installed in several ways.
 - 1) By drilling a hole straight through the outside wall. There is a cutout in the back panel of the appliance to allow the pipe to be concealed within the appliance.
 - 2) The gas pipe can be concealed by cutting a channel in the wall. All current regulations must be adhered to and no pipe joint must be concealed in the wall.

4. Ventilation

- 4.1 This appliance requires no additional ventilation.

Installation Instructions

Site Requirements

5. Appliance Location

i NOTE: THIS APPLIANCE HAS BEEN PRIMARILY DESIGNED TO BE RECESSED INTO THE INTERNAL BRICKWORK OF A STANDARD CAVITY WALL. HOWEVER, IT IS ALSO POSSIBLE TO INSTALL THE APPLIANCE INTO A FALSE CHIMNEY BREAST CONSTRUCTED OF STUDWORK AND HEAT RESISTANT CLADDING.

- 5.1 If this appliance is fitted at floor level (giving a visible opening located 193mm from the floor) then it will require a hearth to protect the floor. The hearth should have a minimum non combustible thickness of 12mm, projecting 300mm in front and 150mm either side of the base of the appliance.

The three methods of studwork installation are:

Frame (see Installation Instructions, Section 5).
Edge (see Installation Instructions, Section 6).
Cool Wall (see Installation Instructions, Section 7).

- 5.2 This appliance must stand on a non-combustible platform that is at least 12mm thick.

! NOTE: WHEN INSTALLING THIS APPLIANCE USING THE 'EDGE' OPTION IT IS RECOMMENDED THAT THE WALL IS FINISHED WITH EITHER SLIPS OR TILES MANUFACTURED FROM STONE OR SIMILAR NATURAL MATERIALS. IF SUCH MATERIALS ARE USED IT IS RECOMMENDED THAT THEY ARE CUT INTO FOUR OR MORE SECTIONS TO PREVENT CRACKING.

RESIN BASED MATERIALS (EG MICRO MARBLE) ARE NOT USUALLY RECOMMENDED DUE TO THE EFFECT OF HEAT ON RESINS. HOWEVER THEY CAN BE USED IF THEY HAVE BEEN MANUFACTURED FOR USE AT ELEVATED TEMPERATURES WITHOUT PRODUCING ANY ODOURS OR STAINING.

- 5.3 A combustible shelf must be:
- Maximum 150mm in depth.
 - Minimum 400mm high above the appliance.
- A combustible side wall must be a minimum of 150mm from the appliance.

- 5.4 This appliance is not suitable for installation onto or against a combustible wall. Remove all combustible material from the area shown, see Diagrams 3 and 4.

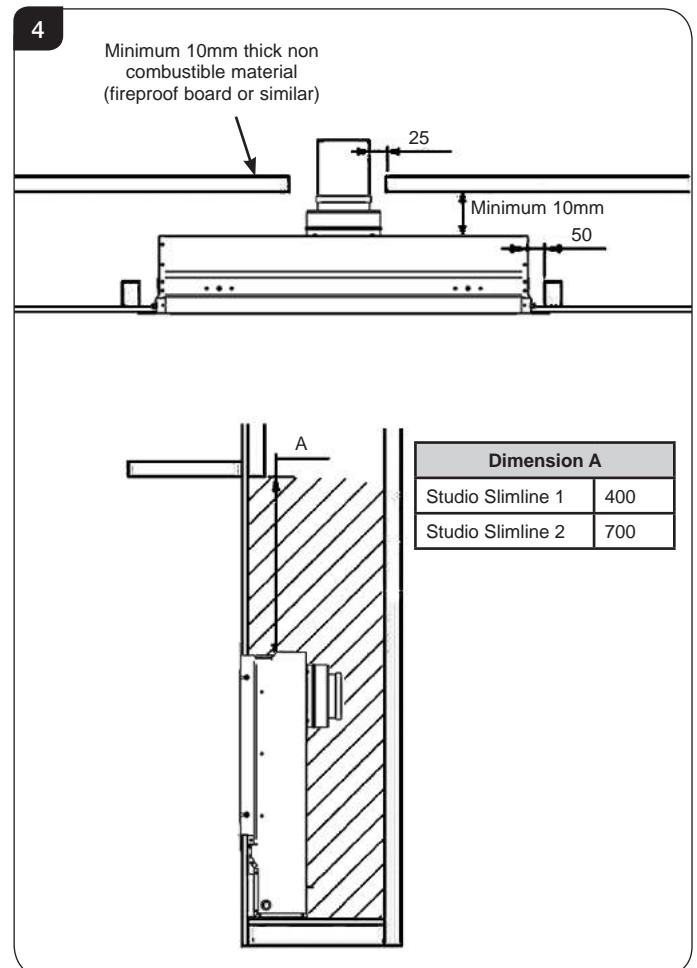
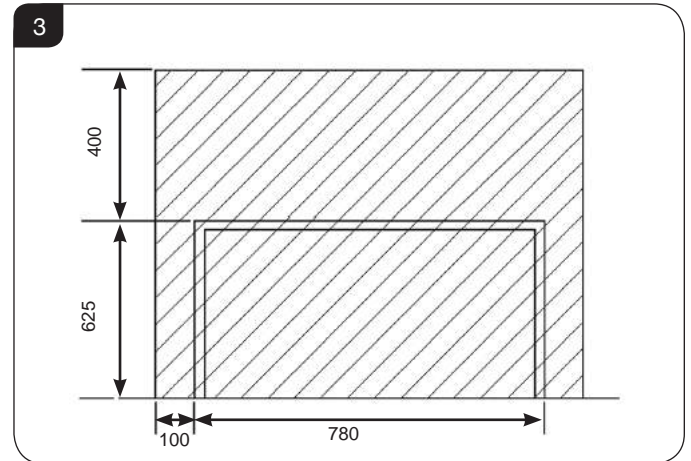

Installation Instructions

1. Safety Precautions

- 1.1 For your own and other's safety, you must install this appliance according to local and national codes of practice. Failure to install the appliance correctly could lead to prosecution. **Read these instructions before installing and using this appliance.**
- 1.2 These instructions must be left intact with the user.
- 1.3 Do not attempt to burn rubbish on this appliance.
- 1.4 Keep all plastic bags away from young children.
- 1.5 Do not place any object on or near to the appliance and allow adequate clearance above the appliance.

IF THE APPLIANCE IS EXTINGUISHED OR GOES OUT IN USE, WAIT 3 MINUTES BEFORE ATTEMPTING TO RELIGHT THE APPLIANCE.

i **IMPORTANT: REFER TO DATA BADGE AND TECHNICAL SPECIFICATION AT THE FRONT OF THE MANUAL TO ENSURE THE APPLIANCE IS CORRECTLY ADJUSTED FOR THE GAS TYPE AND CATEGORY APPLICABLE IN THE COUNTRY OF USE.**

FOR DETAILS OF CHANGING BETWEEN GAS TYPES REFER TO SERVICING, SECTION 15, REPLACING PARTS.

Unpacking

- 1.6 Remove the appliance from its packaging, and check that it is complete and undamaged.

Put the loose ceramic parts to one side so that they are not damaged during installation.

2. Installation of the Appliance

i **Note: This appliance has been designed to fit a masonry opening, however a studwork installation is possible if required.**

- 2.1 To open the glass door, use the hexagon key provided:
- 2.2 Release the window locks moving each from shut to open towards the outer edge of the glass door, see Diagram 1.

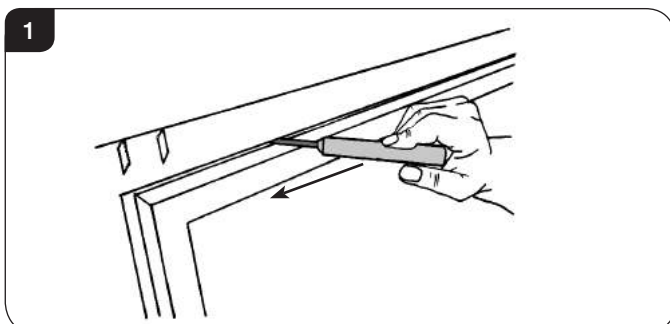

For ease of installation it is advisable to completely remove the glass front:

- 2.3 Remove the securing spring clip from the bottom-right of the window frame, see Diagram 2.

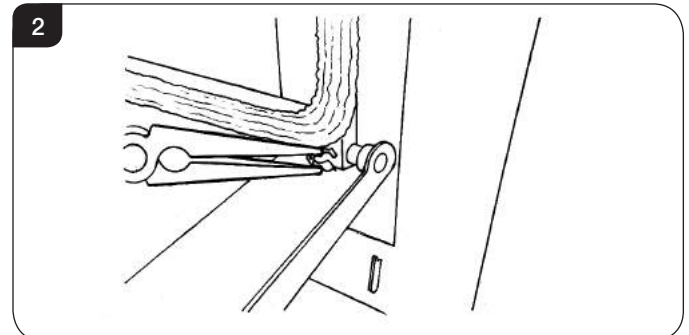

- 2.4 With the window frame in an upright position slide the frame to the left so that it comes off the left hinge pin.
- 2.5 Still keeping the frame upright drop the left side down and forward slightly, see Diagram 3.

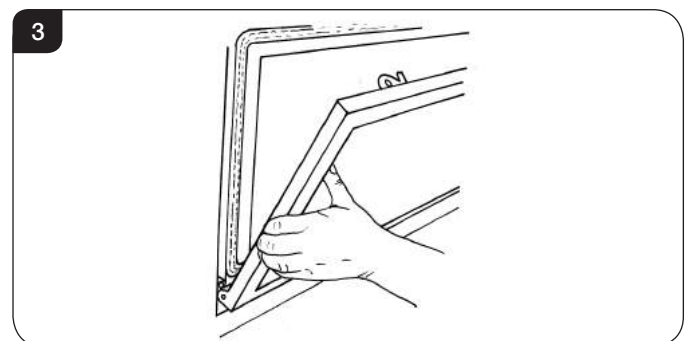

- 2.6 Slide the frame to the right so it comes off the **right** (all models) **and middle** (Studio 2 only) hinge pins. The window frame should now be free.
- 2.7 Place carefully to one side.
- 2.8 Remove all the liners, see Replacing Parts, Section 5.
- 2.9 Remove the Main Burner, see Replacing Parts, Section 6.
- 2.10 Remove the Main Control Assembly, see Replacing Parts, Section 7.
- 2.11 The gas supply enters the appliance through a silicon panel either on the floor or in the back panel under the access panel, see Diagram 4.

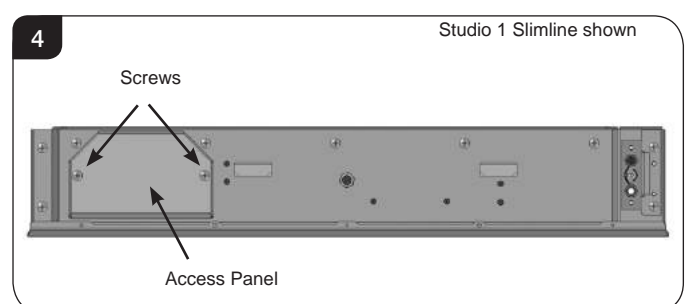

- 2.12 Slit with a sharp knife before bringing through the supply pipe.

Installation Instructions

3. Masonry Installation

This method of installation requires structural alteration to the intended location. A suitable supporting lintel must be installed to maintain the structural integrity of the surrounding blockwork.

There are two types of Masonry Installation:
Finishing with a Decorative Frame.
Using an Edge kit to create a flush finish.

Both these installations will require the same preparation and similar fitting methods. Carefully read and understand the relevant installation section before proceeding.

- 3.1 Mark the position of the lintel so that it sits centrally over the intended installation. Remove the blockwork and install the lintel using mortar to ensure a strong bond with the surrounding wall, see Diagram 5.

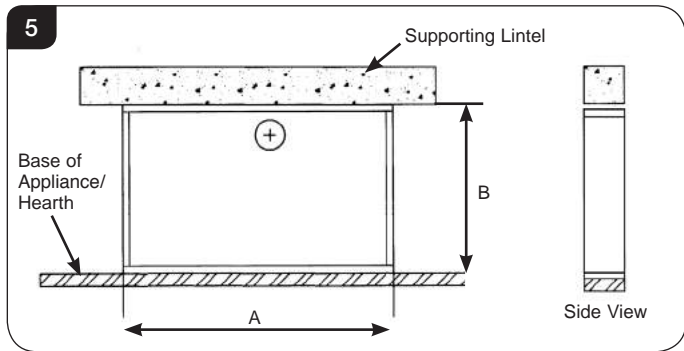

Model	Studio 1 Slimline	Studio 2 Slimline
A	780	980
B	655	655

- 3.2 With the lintel in position mark the width of the aperture and remove the blockwork.
- 3.3 Remove wall finish (eg plaster) from the area shown in Diagram 6 to the size of the appliance and minimum non-combustible clearances in all directions.

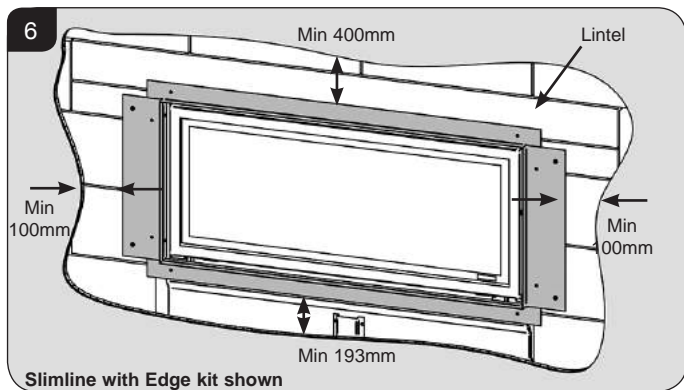

- 3.4 Ensure that there is a minimum of 10mm gap left between the back of the appliance and the outer wall. **There must be no combustible materials behind this appliance.**
- 3.5 Consider the final flue position ensuring that all required clearances are complied with, see Site Requirements Section 1.
- 3.6 Mark the position of the flue on the wall by measuring from the top of the finished hearth level/ base of the appliance, see Diagram 7.

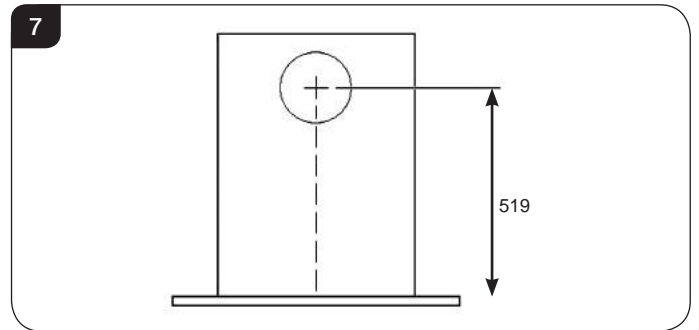

- 3.7 A 152mm (6") diameter hole is required to install the flue. This can be achieved by either:
 a) Core drill
 b) Hammer and chisel
 It is advisable to drill small holes around the circumference when using method b. Make good both ends of the hole.
- 3.8 Line the sides, top and bottom of the opening with non-combustible board to prevent heat entering the cavity.
- 3.9 Prepare gas supply and cable. If installing into a cavity, no joints should be within the cavity and the pipe must be sleeved. Refer to gas installation requirements.
- 3.10 Install the battery cable and wall plate box. Gazco recommend that the cable is installed through conduit or similar to give protection and allow for future servicing.

When deciding the route of the cables consideration must be given to avoid contact with the appliance and the flue system.

! IMPORTANT - Do not run the battery cable up the side of the appliance outer casing.

See Section 9 for wall box and batteries installation.

i The wall box must be installed using a non-metallic mounting box, please ensure that the plastic dry lining box is used where possible. For masonry installation it is possible to drill through the rear of the box and secure in position using wall plugs and screws although a small amount of finishing work will be required to cover the plastic side securing tags. Alternatively a standard 45mm (or greater) deep pattress box can be used to surface mount the wall plate.

Installation Instructions

Finishing with a Decorative Frame - step 1

- 3.11 Position the appliance minus the subframe in the aperture, ensure that the appliance is level and that the front edge aligns with the proposed front face of the wall.
- 3.12 Mark the fixing holes in the base of the appliance.
- 3.13 Remove the appliance then drill and plug the holes.
- 3.14 Position the appliance in the aperture. It will be necessary to pass the gas supply pipe with the elbow through the silicone panel and the battery cable through the left or right hand rubber grommit.
- 3.15 Secure the appliance through the fixing holes in the base and check the appliance is level, see Diagram 8.

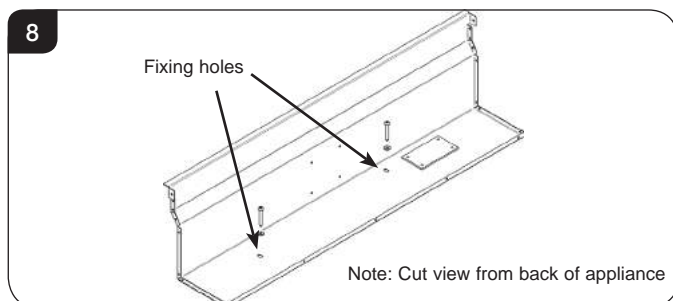

Proceed to Section 3.20 or 3.23 depending on how the wall is to be finished.
Note: the Decorative frame will require an additional step following the finishing of the wall.

Creating an Edge finish



NOTE: WHEN INSTALLING THIS APPLIANCE USING THE 'EDGE' OPTION IT IS RECOMMENDED THAT THE WALL IS FINISHED WITH EITHER SLIPS OR TILES MANUFACTURED FROM STONE OR SIMILAR NATURAL MATERIALS. IF SUCH MATERIALS ARE USED IT IS RECOMMENDED THAT THEY ARE CUT INTO FOUR OR MORE SECTIONS TO PREVENT CRACKING.

RESIN BASED MATERIALS (EG MICRO MARBLE) ARE NOT USUALLY RECOMMENDED DUE TO THE EFFECT OF HEAT ON RESINS. HOWEVER THEY CAN BE USED IF THEY HAVE BEEN MANUFACTURED FOR USE AT ELEVATED TEMPERATURES WITHOUT PRODUCING ANY ODOURS OR STRAINING.

There is an optional Studio Edge Installation Kit available for installing the appliance without a frame.

Using the installation kit:

- 3.16 With the sub-frame already secured to the appliance, fit the 4 metal brackets of the kit to the sub-frame and secure using the supplied fixings, see Diagram 9.

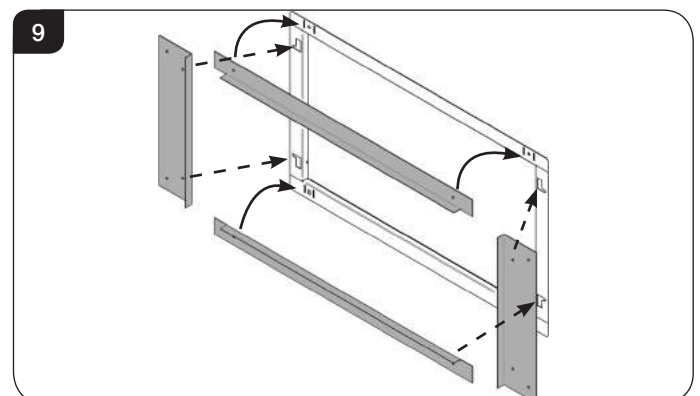

- 3.17 Fix foam seal to the rear of the outer flange of the appliance, see Diagram 10.

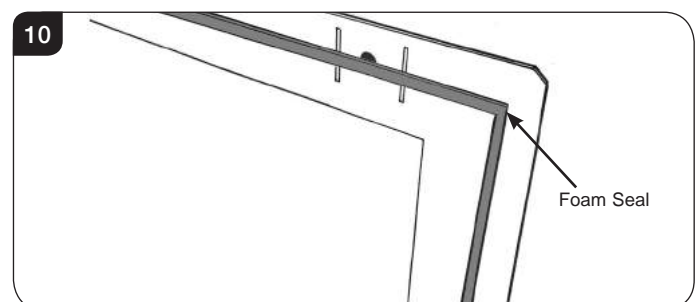

- 3.19 Secure the appliance to the wall through the holes in the Edge kit with the screws provided.

Installation Instructions

All Installations



IMPORTANT:

Once the appliance is in position there are 2 methods of finishing the wall.

A) Lining with heat resistant board which is then finished with a heat resistant plaster skim and decorated as required.

B) Reinstating the removed wall finish using a heat resistant render which is finished with a heat resistant plaster skim and decorated as required.

Finishing Method A

- 3.20 Fit non-combustible board to the wall around the appliance. This should extend a minimum of 400mm above the appliance and 100mm at the sides, but ideally should cover a greater area to prevent cracking of the finished wall see Diagram 12.

Cut notches into the board to allow clearance for the subframe fixings.

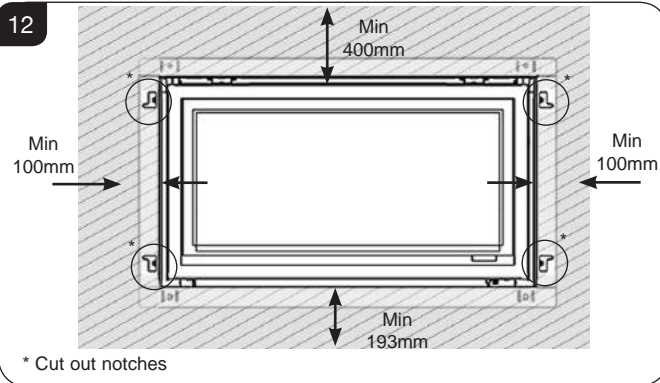

- 3.21 Fit plasterboard to the remaining chimney breast front.
- 3.22 After taking the normal steps to join the heat resistant board and plasterboard correctly, finish the whole area with a heat resistant plaster skim in the area directly around the appliance, see Diagram 13a or 13b.

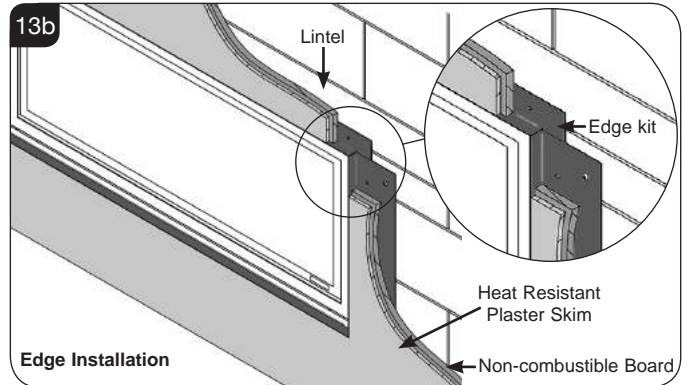
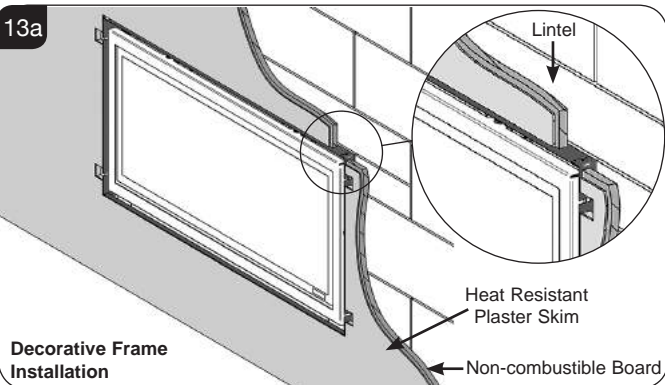

Finishing Method B

- 3.23 Apply a render to the exposed wall using the Edge Frame as a guide. The render should finish 3-5mm shy of the finished wall face to allow for a final finish in Heat Resistant plaster skim to be applied.
- 3.24 Reinstall the remaining removed wall finish using a heat resistant render and finish with a heat resistant plaster skim.

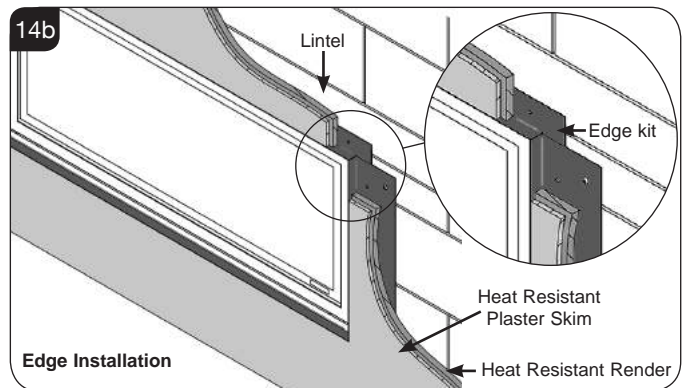
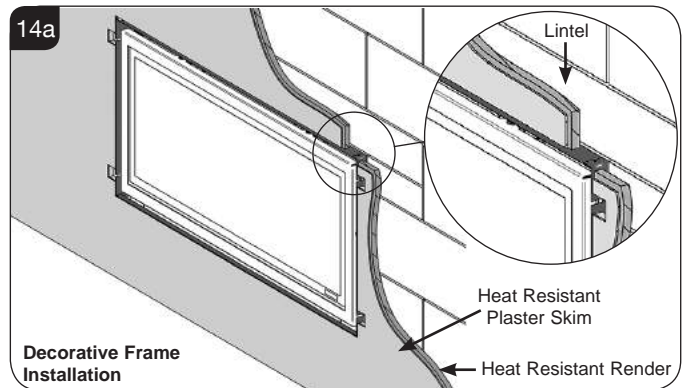

- 3.25 **Decorated as required.**
Note there are no more steps required for a seamless Edge finish.

Finishing with a Decorative Frame - step 2

- 3.26 Attach the 4 x frame fixing brackets to the sub-frame, see Diagram 15.

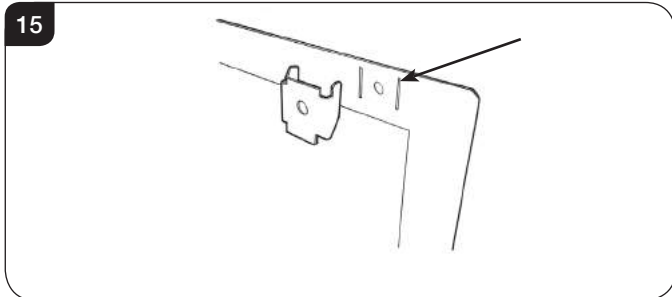

- 3.27 Fix foam seal to the rear of the outer flange of the appliance, see Diagram 16.

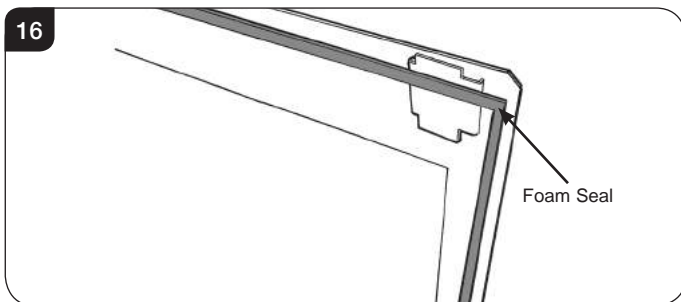

- 3.28 Fit the sub-frame to the appliance and ensure the returns of the sub-frame fit internally into the main outer box with the studs and securing nuts passing through the side slots. Secure by tightening the 4 nuts, see Diagram 17.

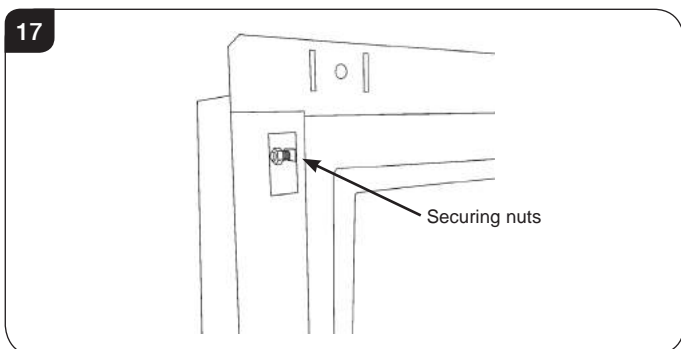

- 3.29 Secure the appliance and sub-frame to wall through the holes in the sub-frame with the screws provided.

Installation Instructions

- 3.30 If the finished wall does not line up with the top fixing holes in the sub-frame then the side holes can be used to fix the frame back to the wall. However, the frame fixing brackets **must** be fixed to the sub-frame.

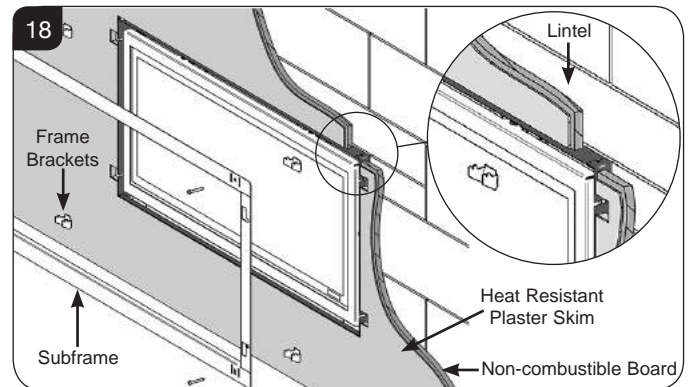

- 3.31 Screw the lower frame fixings through the sub-frame at the base of the appliance.

- 3.32 Fit the decorative front referring to individual installation instructions.

Installation Instructions

4. Studwork Installation

THERE ARE THREE TYPES OF INSTALLATION INTO STUDWORK DESCRIBED IN THE FOLLOWING PAGES:

- 1) FOR STUDIO SLIMLINE WITH DECORATIVE FRONT (SEE SECTION 5).
- 2) FOR AN INSTALLATION WHERE THE STUDIO SLIMLINE SITS FLUSH TO THE FINISHED 'EDGE' OF THE WALL (SEE SECTION 6).
- 3) FOR A FURTHER 'EDGE' INSTALLATION PROVIDING A COOL WALL ABOVE THE APPLIANCE TO ALLOW CUSTOMERS TO HANG PICTURES ETC. (SEE SECTION 7).

i **IMPORTANT: NEVER position a television or screen above this appliance.**

4.1 DISTANCE TO COMBUSTIBLE MATERIAL

COMBUSTIBLE PARTS OF THE STUDWORK MUST BE KEPT BEYOND THE MINIMUM DIMENSIONS SHOWN IN DIAGRAM 19. EVEN IF THE FRAMEWORK IS PROTECTED BY NON-COMBUSTIBLE MATERIAL, YOU MUST MAINTAIN THESE DIMENSIONS, SEE DIAGRAM 19.

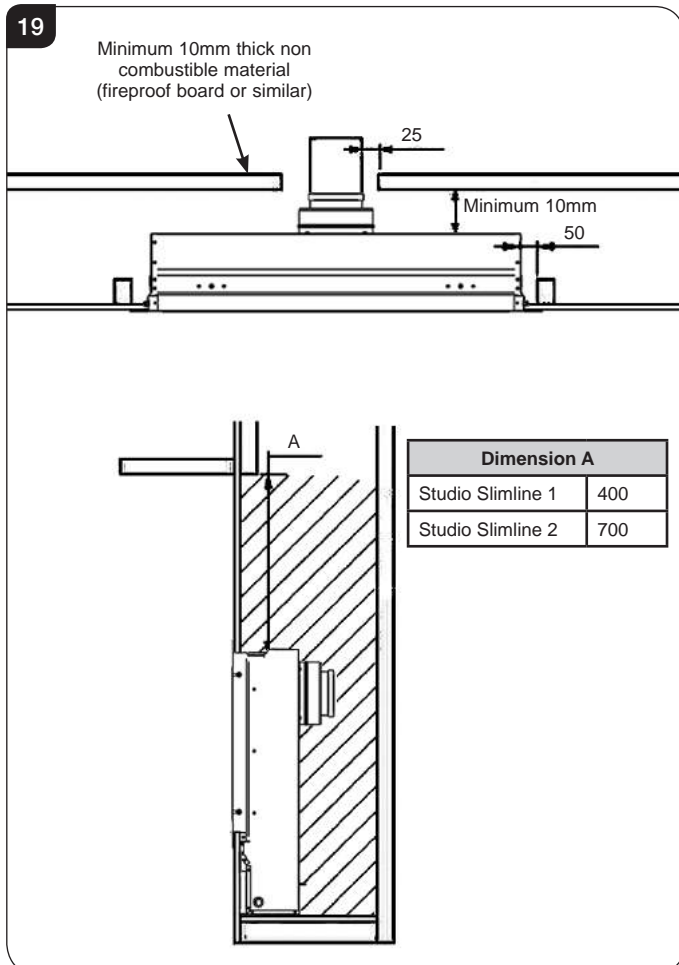

- 4.2 DO NOT PACK THE VOID AROUND OR ABOVE THE APPLIANCE WITH INSULATION MATERIALS SUCH AS MINERAL WOOL.
- 4.3 THE VOID BUILT FOR THE CASSETTE MUST BE VENTILATED TO PREVENT A BUILD-UP OF HEAT. IF THE VOID IS SEALED, THEN YOU MUST FIT VENTS AT BOTH LOW AND HIGH LEVELS OF APPROXIMATELY 50CM² EACH. THESE VENTS MUST TAKE COLD AIR FROM THE ROOM AND RETURN WARM AIR BACK INTO THE ROOM.
- 4.4 AN ACCESS HATCH MUST BE LEFT IN THE SIDE OF THE CHIMNEY BREAST FOR FUTURE SERVICING AND INSPECTION OF THE FLUE AND APPLIANCE.

5. Studwork Installation for Studio with frames

- 5.1 Build the studwork chimney breast and enclosures to the desired size to include the protected platform at the required height.
- 5.2 Line the aperture for the appliance with 12mm thick non-combustible material as shown, see Diagram 20.

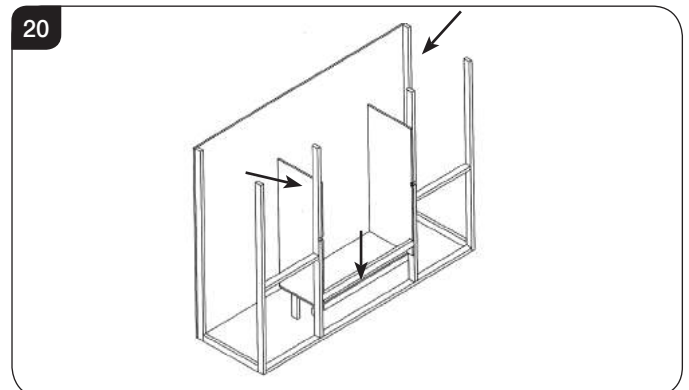

- 5.3 Ensure the clearances are maintained, see Diagram 19.
- 5.4 Site the appliance and decide on flue requirements.
- 5.5 Cut a hole for the flue exit, see Installation Instructions, Section 4.
- 5.6 Provide gas services into the cassette void on the left-hand side.

Because no combustible material can be used above the appliance, we provide a support bar:

Installation Instructions

- 5.7 Mark out the position to fit the supplied top support bar into the studwork at the correct height. This bar needs to be recessed into the studwork, see Diagram 21.

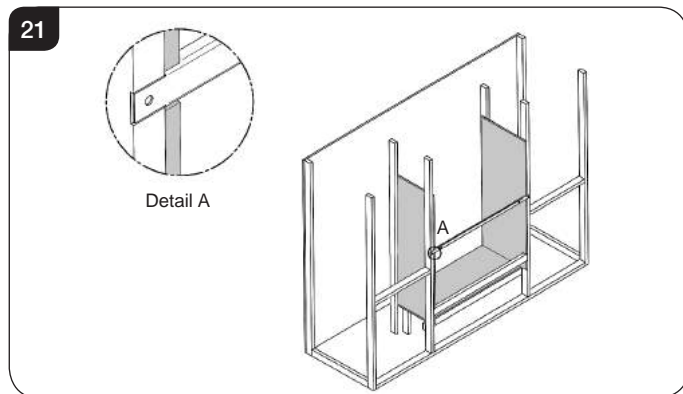

- 5.8 Fit the support bar into the studwork at the correct height, see Diagram 22.

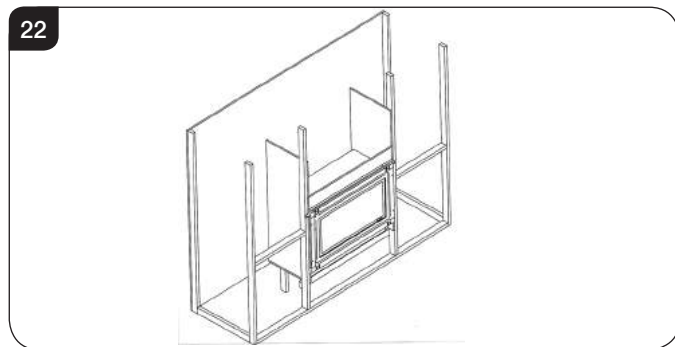

- 5.9 Position the appliance in the aperture, ensure that the appliance is level and that the front edge aligns with the proposed front edge of the wall.
- 5.10 Secure the appliance to the base of the studwork plinth using the fixing screws supplied, see Diagram 23.

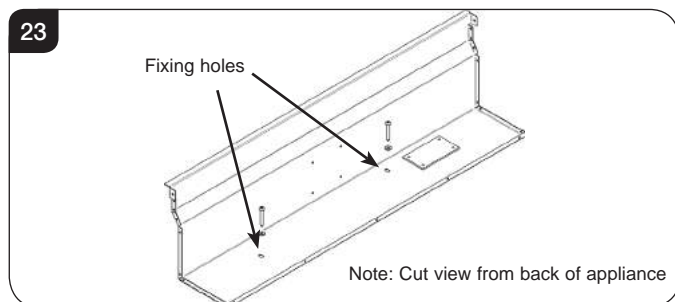

- 5.11 Fit non-combustible board to the studwork around the appliance. This should extend a minimum of 400mm above and at least 100mm to the sides of the appliance, leaving a minimum of 15mm gap either side of the appliance to allow clearance for the sub frame fixings, see Diagram 24.

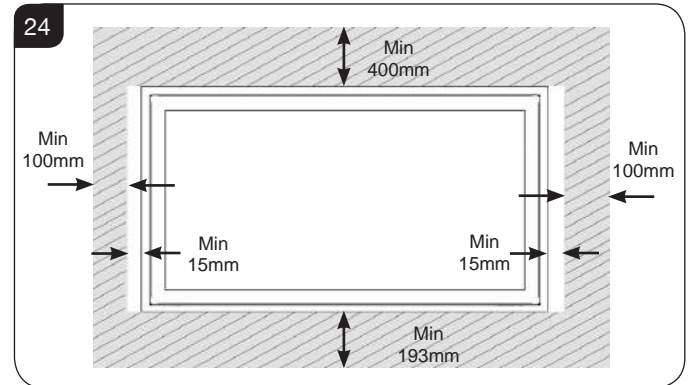

- 5.12 Apply plasterboard to the remainder of the studwork.
- 5.13 Apply a plaster finish to the front of the chimney breast, ensuring that heat resistant plaster is used in the areas shown in Diagram 24.
- 5.14 Attach the 4 x frame fixing brackets to the sub-frame, see Diagram 25.

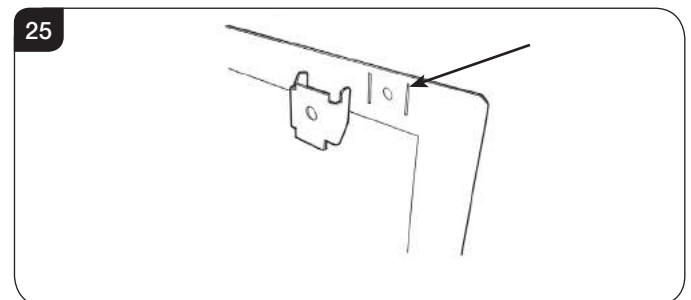

- 5.15 Fix foam seal to the rear of the outer flange of the appliance, see Diagram 26.

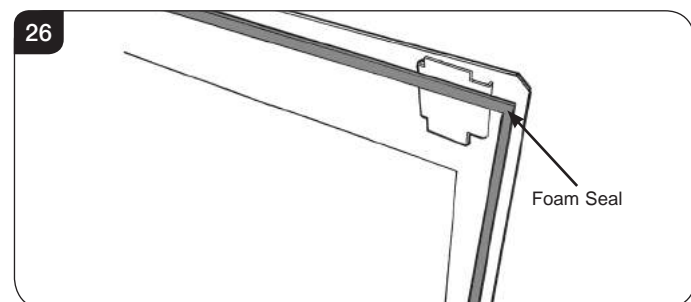

Installation Instructions

- 5.16 Fit the sub-frame to the appliance and ensure the returns of the sub-frame fit internally into the main outer box with the studs and securing nuts passing through the side slots. Secure by tightening the 4 nuts, see Diagram 27.

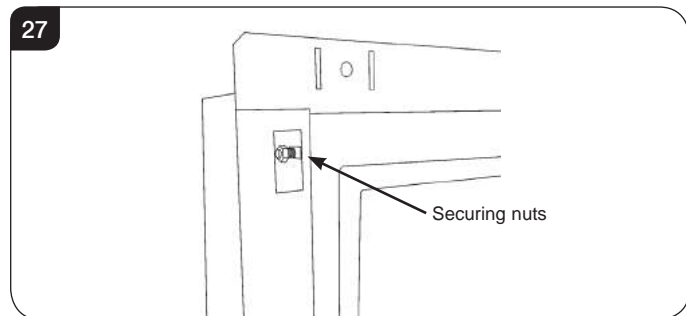

- 5.17 Secure the appliance to the studwork using four screws through flange, bracket and support bar.

Slips

Because of the high temperatures this appliance achieves, it is advisable to use marble slips or similar material between the appliance and the plasterboard.

Never use a one-piece slip as expansion (even cracking) can occur.

Note: If a slip is used, longer screws are needed to secure the appliance.

To finish this installation:

- 5.18 Connect the wall box and batteries following the instructions in Section 11.
- 5.19 Connect:
- The flue system, see Installation, Section 9.
 - Gas services, see Installation, Section 2, using the opening in the side of the chimney breast for access.

After commissioning:

- 5.20 Finish the sides of the chimney breast, see Diagram 28.

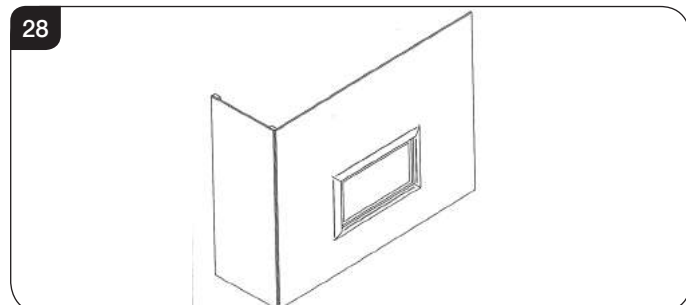

6. Studwork for Edge installation kit

There is an optional Studio Edge Installation Kit available for installing the appliance without a frame: Studio Code No. 8727BF EK01.

Using the installation kit:

- 6.1 Fit the four metal brackets of the kit to the sub-frame, see Diagram 29.

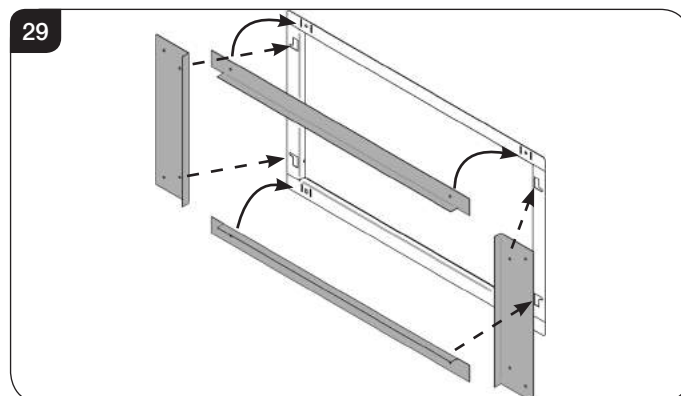

- 6.2 Fix foam seal to the rear of the outer flange of the appliance, see Diagram 30.

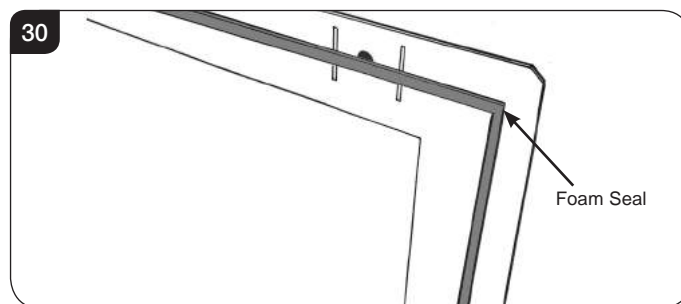

- 6.3 Fit the sub-frame to the appliance and ensure the returns of the sub-frame fit internally into the main outer box with the studs and securing nuts passing through the side slots. Secure by tightening the 4 nuts, see Diagram 31.

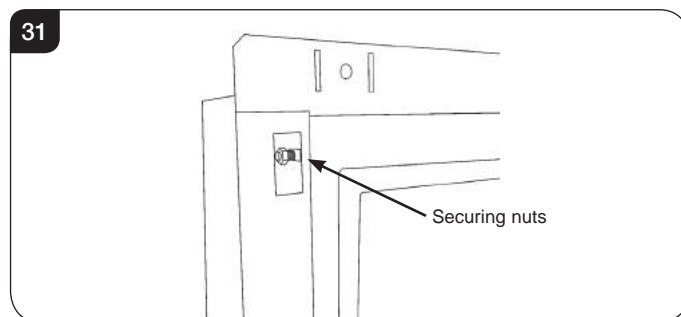

- 6.4 Build the studwork chimney breast to the desired size.
- 6.5 Ensure all clearances to combustible material are maintained, see Section 4.
- 6.6 Put vertical studwork at minimum clearance to the side of the appliance (50mm).
- 6.7 Decide on flue requirements.

Installation Instructions

- 6.8 Cut a hole for the flue exit, see Installation Instructions, Section 32.

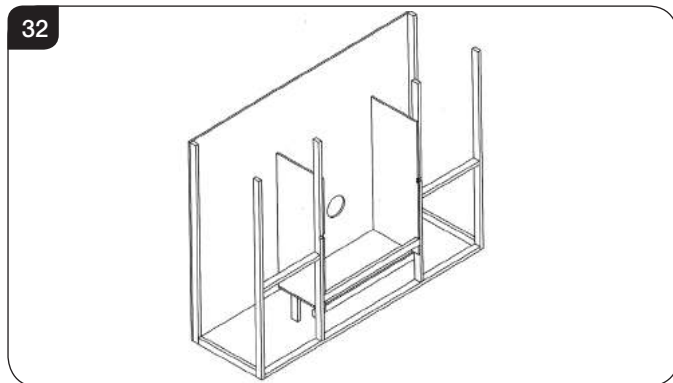

- 6.9 Secure to the vertical studwork through the holes in the metal brackets fitted to the appliance.
- 6.10 The kit has been designed so that non-combustible board can be taken right up to the edge of the four brackets, see Diagrams 33 & 34.

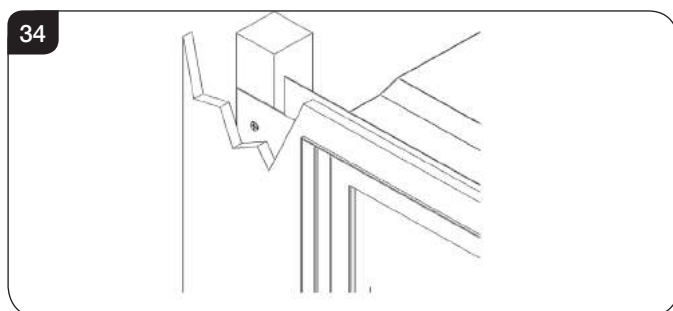
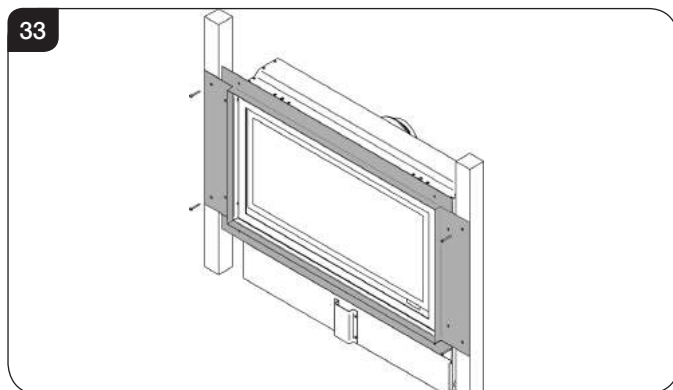

- 6.11 Fit non-combustible board to the studwork above the appliance. This should extend a minimum of 400mm above the appliance and 100mm to the sides, see Diagram 35.

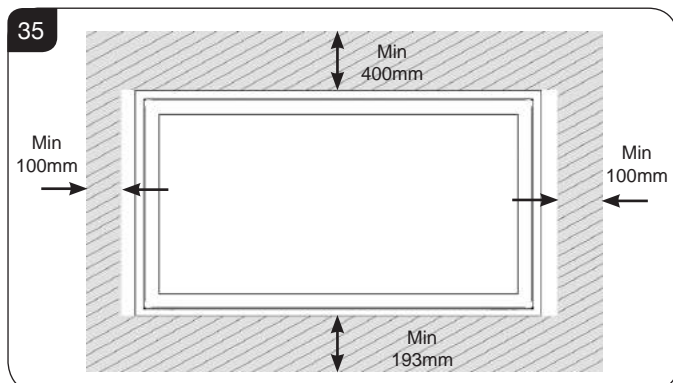

- 6.12 Fit plasterboard to the remaining chimney breast front.
- 6.13 Connect the flue system and gas services using the opening in the side of the chimney breast for access.
- 6.14 After commissioning, finish the sides of the chimney breast, see Diagram 36.

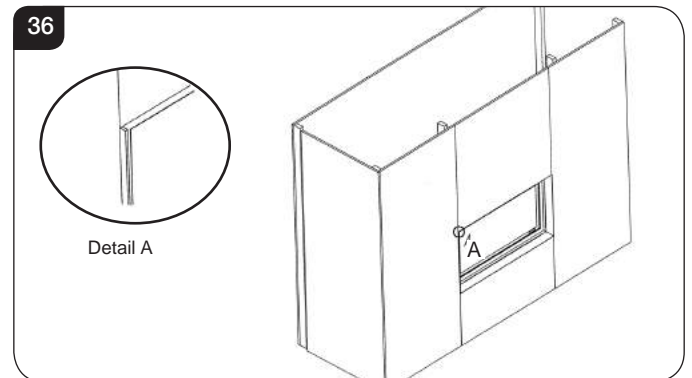

- 6.15 Apply a plaster finish to the chimney breast using heat resistant plaster in the area directly around the appliance, see Diagram 36.

7. Studwork for Cool Wall installation kit

For this cool-wall installation, the convected heat produced by the appliance is channelled into the chimney cavity and vented at the top.

The cool wall installation kit is provided unfinished. This allows the kit to be finished to match the front face decor.

There is an optional Studio Cool Wall Installation Kit available for installing the appliance without a frame.

Using the fixing kit:

- 7.1 Fit the four metal brackets of the kit to the sub-frame, see Diagram 37. There is a deliberate gap at the top for convected heat.

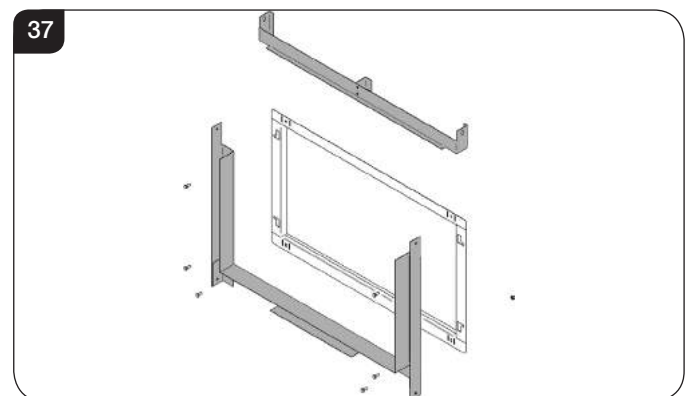

Installation Instructions

- 7.2 Fit the sub-frame to the appliance and ensure the returns of the sub-frame fit internally into the main outer box with the studs and securing nuts passing through the side slots. Secure by tightening the 4 nuts, see Diagram 38.

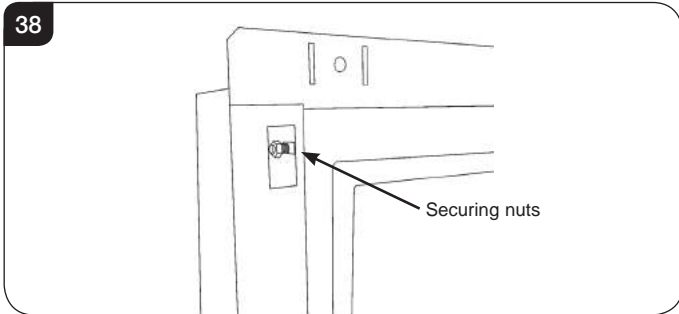

- 7.3 This now determines the width of your two vertical studwork supports. The kit has been designed so that non-combustible board can be taken right up to the edge of the four brackets, see Diagrams 39 & 40.

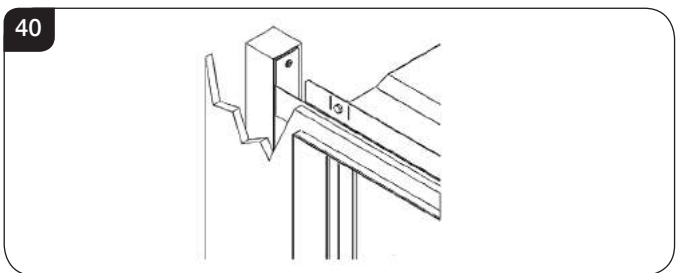
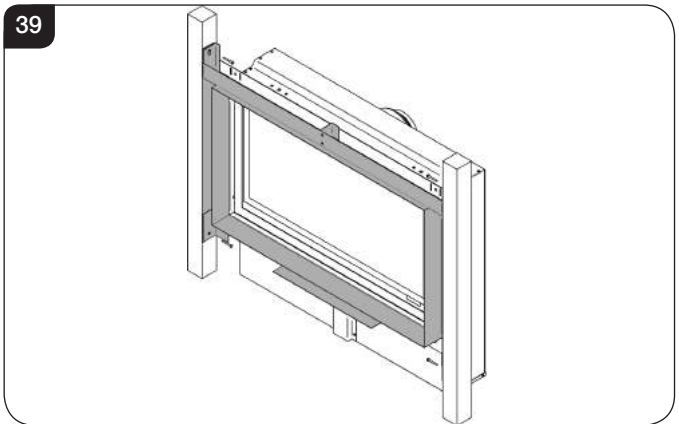

- 7.4 Fix the left and right metal brackets into the studwork. Build the studwork chimney breast to the desired size.
- 7.5 Ensure all clearances to combustible material are maintained, see Section 4.
- 7.6 Decide on flue requirements.

- 7.7 Cut a hole for the flue exit, see Installation Instructions, Section 8.

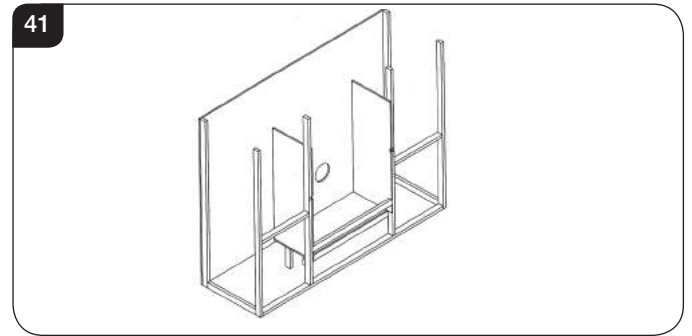

- 7.8 Fit non-combustible board to the studwork above the appliance. This should extend a minimum of 400mm above the appliance and 100mm to the sides, see Diagram 41.
- 7.9 Fit plasterboard to the remaining chimney breast front.
- 7.10 Connect the flue system and gas services using the opening in the side of the chimney breast for access.
- 7.11 After commissioning, finish the sides of the chimney breast, see Diagram 42.

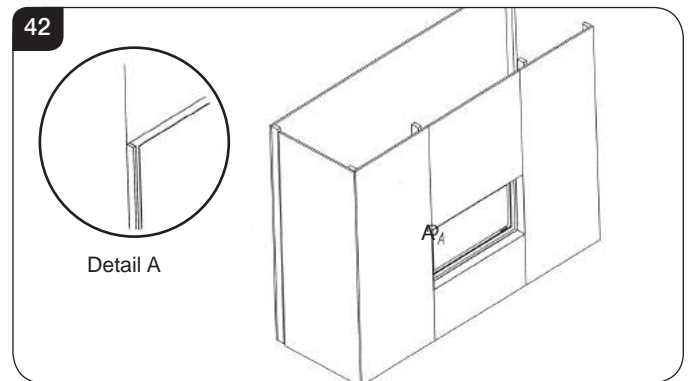

- 7.12 **The top of the chimney breast must have a minimum 200cm² vent.**
- 7.13 Apply a plaster finish to the chimney breast using heat resistant plaster in the area directly around the appliance, see Diagram 43.

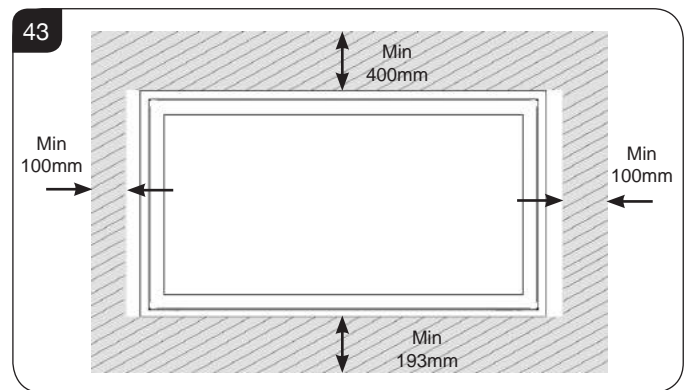

Installation Instructions

8. Flue Assembly

- 8.1 **FLUE LENGTH:** **MIN = 90mm**
 MAX = 550mm
- 8.2 Unpack the flue assembly and terminal guard.
- 8.3 Do not lose the fixings.
- 8.4 Consider the final appliance position ensuring you comply with clearances required for the external flue, see Site Requirements, Section 1.
- 8.5 Mark the vertical centre-line of the appliance on the wall, see Diagram 19, A.
- 8.6 Mark the height from the top of the hearth/ base of appliance to the centre of the flue, see Diagram 19, B.

TAKE CARE TO MARK OUT THE FLUE CORRECTLY. IT IS DIFFICULT TO MOVE AFTER INSTALLATION.

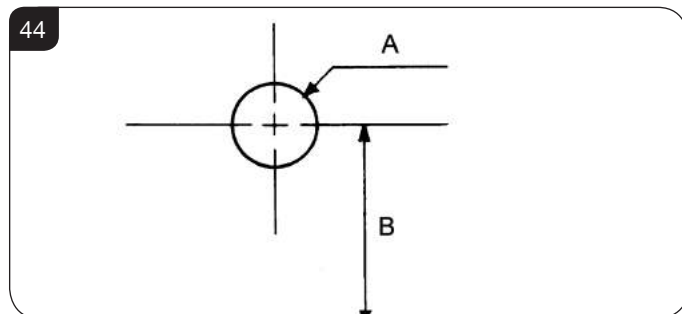

Flue Length

- 8.7 With the appliance secured in place, (minimum 10mm gap between the back of appliance and the wall) measure the distance from the back of the appliance to the outside face of the wall. Deduct 18mm from this measurement.
- 8.8 Insert the square cardboard sleeve into the flue to support the inner tube.
- 8.9 Cut through the flue and sleeve, see Diagram 45.

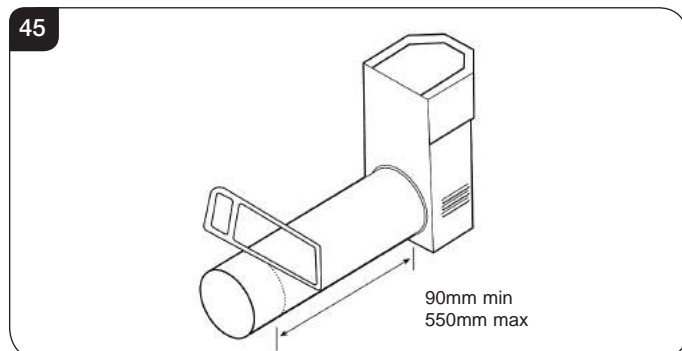

- 8.10 **REMOVE THE CARDBOARD REMNANTS FROM THE FLUE.**
- 8.11 File the cut edges smooth.

Terminal

On the outside wall:

- 8.12 Position the flue assembly into the hole. The terminal should be flat against the wall.
- 8.13 Make sure the terminal is vertical, see Diagram 46
- 8.14 Mark the 4 fixing holes.
- 8.15 Remove the terminal to drill the holes.
- 8.16 Insert wall plugs supplied.

DO NOT FIX THE FLUE AT THIS STAGE.

Flue and Appliance Fixings

- 8.17 Position the appliance observing appropriate clearances.
- 8.18 Apply a bead of suitable weatherproof sealant (silicone or similar) to perimeter of back face of terminal, see Diagram 21.

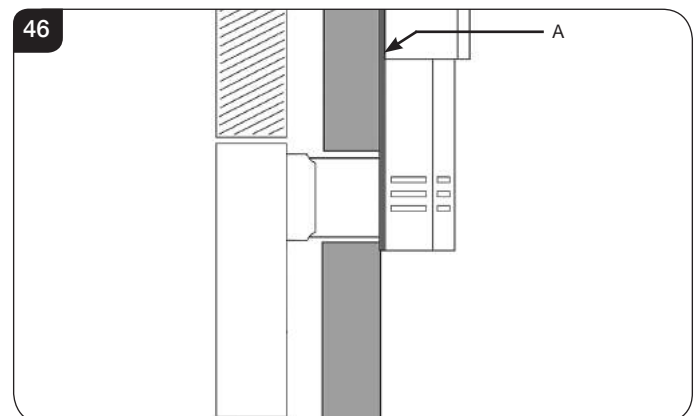

- 8.19 Feed the flue through the wall, making sure it runs smoothly.
- 8.20 Engage the flue in the inner and outer spigots.
- 8.21 Make sure rubber seal on the inner spigot is not damaged, it may be necessary to lubricate the seals with washing up liquid (or similar) to ease assembly.

Installation Instructions

i To ensure a successful installation take out the baffle plate by removing the 8 fixing screws, see Diagram 47.

It is now possible to view if the end of the flue is located correctly, see Diagram 48.

Note: Studio 1 Slimline shown in diagram but fixing points are the same for all models.

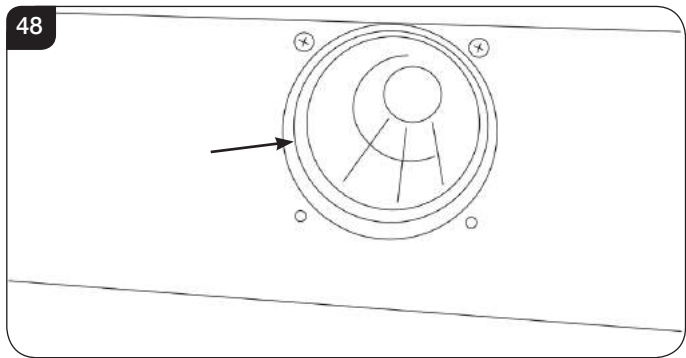
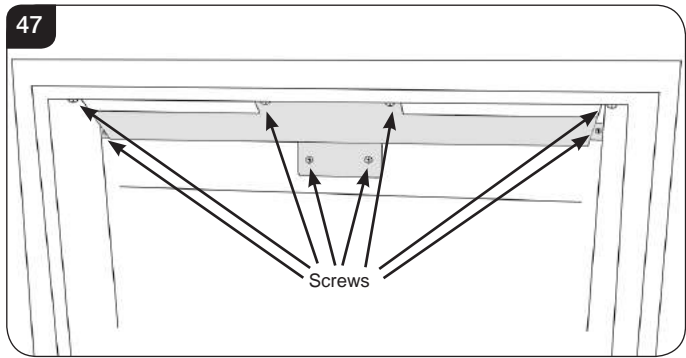

- 8.22 Insert 4 screws in the flanges of the flue terminal.
- 8.23 Check sealant has formed a water-tight joint to the wall.
- 8.24 Any terminal less than 2m above any access (level ground, balcony or flat roof with access) must be fitted with the guard supplied, see Diagram 49.

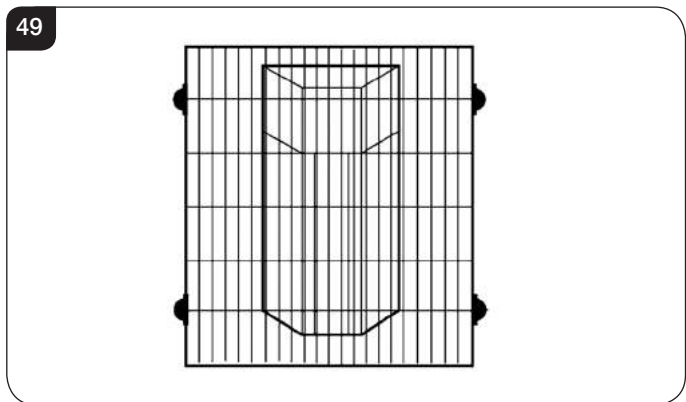

9. All types of Installation - Wall Box & Batteries

i **Please note: As an optional extra Gazco can provide a mains adapter to supply constant power to the appliance control box instead of the battery pack.**

If installing an appliance with the adapter make provision for a mains power socket within 1.5m of the control box and follow the instructions provided.

When installing the wall box allow at least 100mm of slack wire in the battery lead where it enters the appliance on the right hand side. This allows the removal of the control assembly during servicing.

- 9.1 Decide on the position for the wall box containing the batteries and wall plate and cut the necessary hole.
- A battery power supply cable is supplied and pre-fitted to the appliance control. Provision is made for the cable to exit either the left or right of the appliance through the grommet. The cable is 3 metres long.
- 9.2 Connect the wire from the appliance to the battery pack, see Diagram 50.

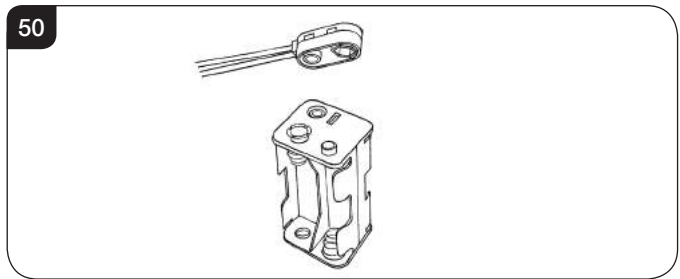

- 9.3 Correctly position the four new AA size batteries and re-assemble the battery holder as shown, see Diagram 51.

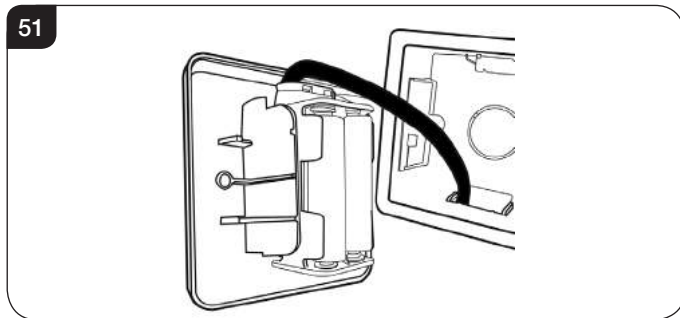

Installation Instructions

- 9.4 Secure the wall plate to the wall box using the two fixing screws, see Diagram 52.

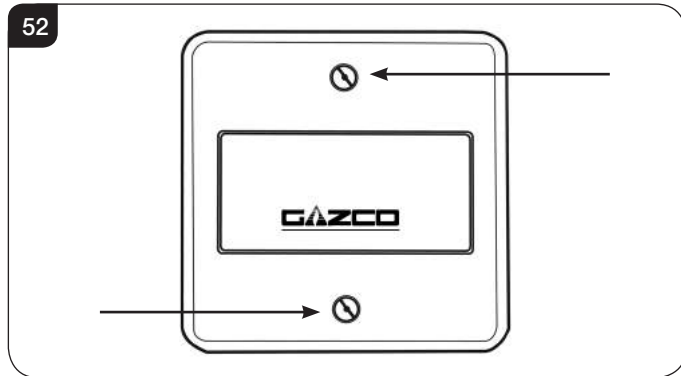

i **IMPORTANT**
The wall plate must be installed using a non-metallic mounting box, please ensure that the plastic dry lining box is used wherever possible. If it is intended to install the wall plate into masonry it is possible to drill through the rear of this box and secure in position using wall plugs and screws although a small amount of finishing work will be required to cover the plastic side securing tags. Alternatively a standard 47mm deep pattress box can be used to surface mount the wall plate.

PLEASE ENSURE NO WIRES ARE TRAPPED BEFORE REPLACING THE WALL PLATE. THE LEAD IS EASILY DAMAGED.

10. Assembling the Appliance

LINERS

- 10.1 The Slimline Studio appliance has the option of three different liner finishes:
Vermiculite
Black Reeded
Brick Effect
- 10.2 There are two clips at the top of the firebox that are used to secure the back panel in position. These must be removed before fitting the liners, see Diagram 53.

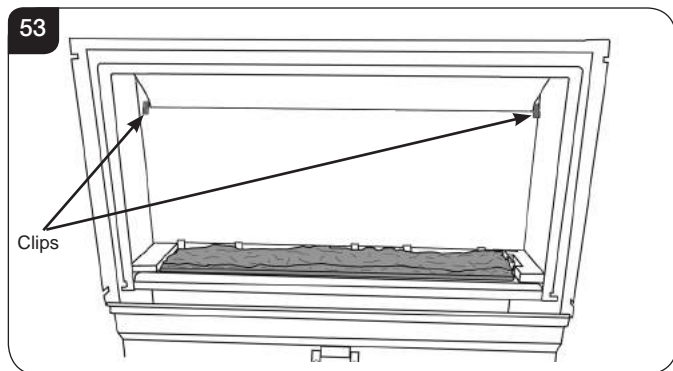

- 10.3 Place the Bottom Side Liners against the side and back of the firebox, then fit back liner panel into position against the back of the appliance, see Diagram 54.

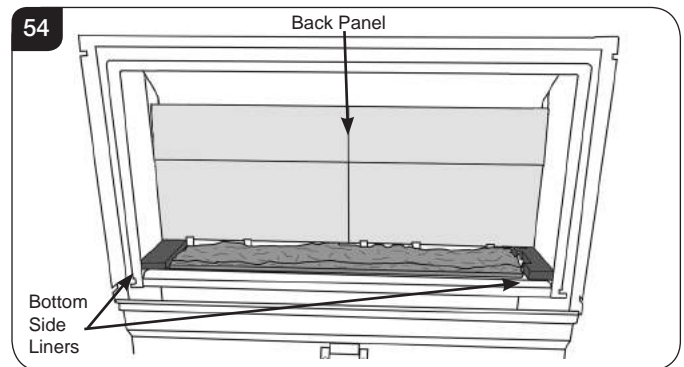

- 10.4 Reattach the two clips to hold the back panel in place, see Diagram 55.

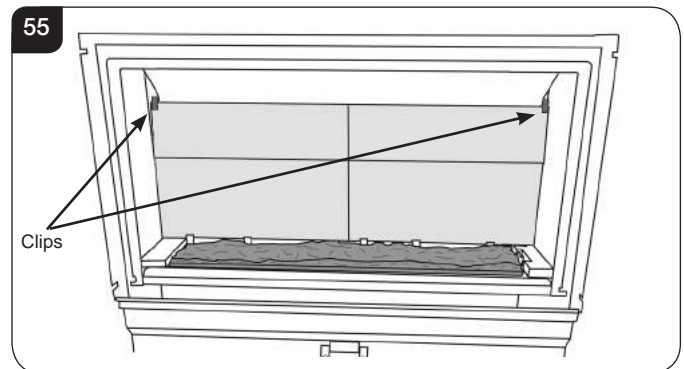

- 10.5 Slide the two side liners into place to finish, see Diagram 56.

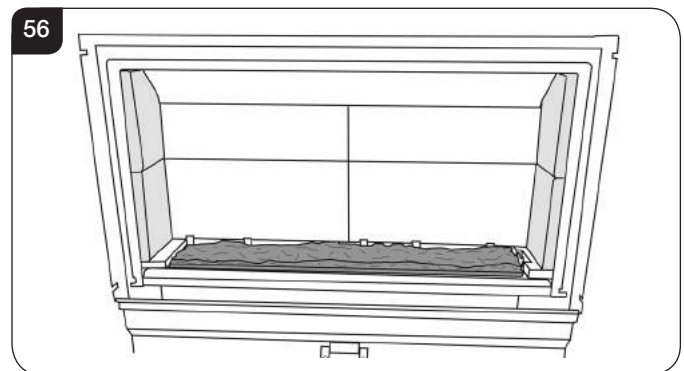

- 10.6 Removal of the liners is the reverse of this process.

Installation Instructions

11. Arrangement of the fuel bed

Advice on handling and disposal of fire ceramics



The fuel effect and liners of this appliance are made from Refractory Ceramic Fibre (RCF), a material which is commonly used for this application.

Protective clothing is not required when handling these articles, but we recommend you follow normal hygiene rules of not smoking, eating or drinking in the work area and always wash your hands before eating or drinking.

To ensure that the release of RCF fibres are kept to a minimum, during installation and servicing a HEPA filtered vacuum is recommended to remove any dust accumulated in and around the appliance before and after working on it. When servicing the appliance it is recommended that the replaced items are not broken up, but are sealed within heavy duty polythene bags and labelled as RCF waste.

RCF waste is classed as stable, non-reactive hazardous waste and may be disposed of at a licensed landfill site.

Excessive exposure to these materials may cause temporary irritation to eyes, skin and respiratory tract; wash hands thoroughly after handling the material.

12. Log Layout

LOGS MUST BE POSITIONED ACCORDING TO THE FOLLOWING INSTRUCTIONS TO GIVE THE CORRECT FLAME EFFECT

Studio 1 Layout

- 12.1 Ensure the burner tray is clean and free from any debris.
- 12.2 All logs can be identified by a letter (A - D) on their underside.

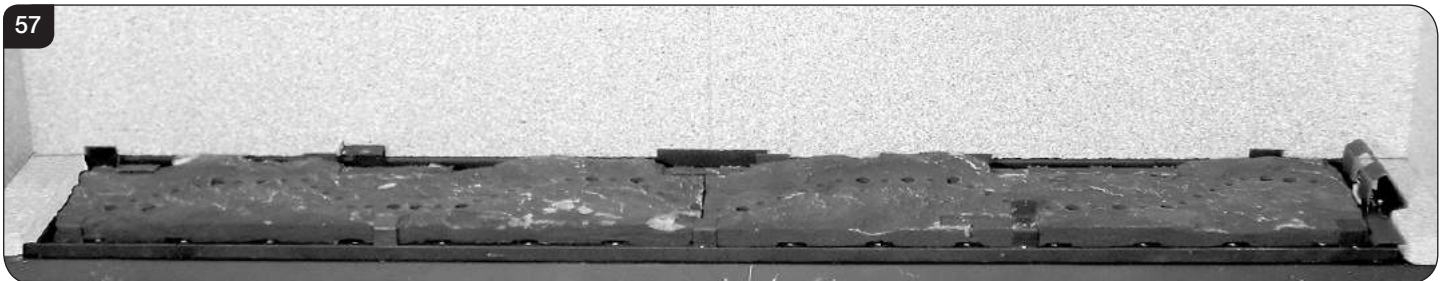

Installation Instructions

- 12.3 Position Log A between the two tabs at the back of the burner tray, see Diagram 58. The left hand side should rest on the tab at the back of the burner tray and be pushed up to the supporting lip, see Diagram 58 Detail.

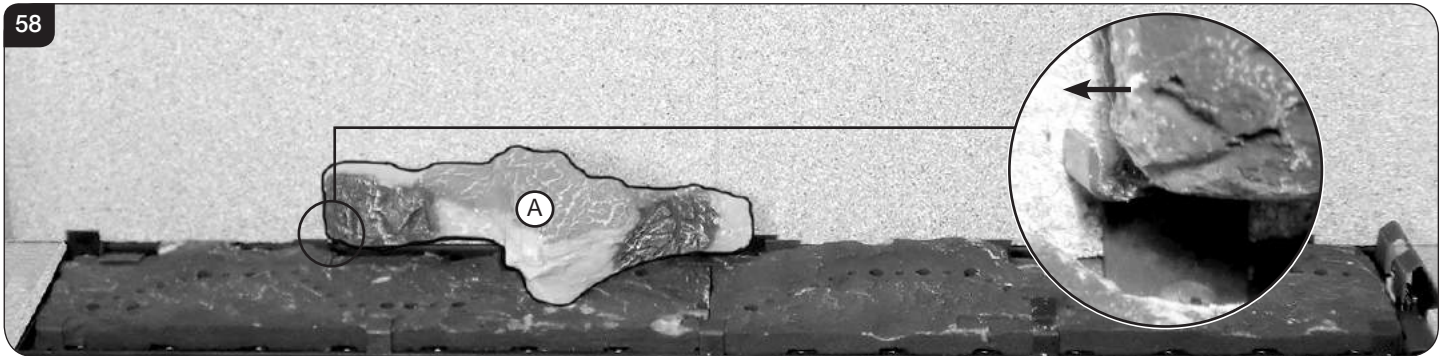

- 12.4 Place the left hand end of Log B against the back right tab on the burner tray, see Diagram 59. Ensure that the front branch is in line with the front of the burner tray.

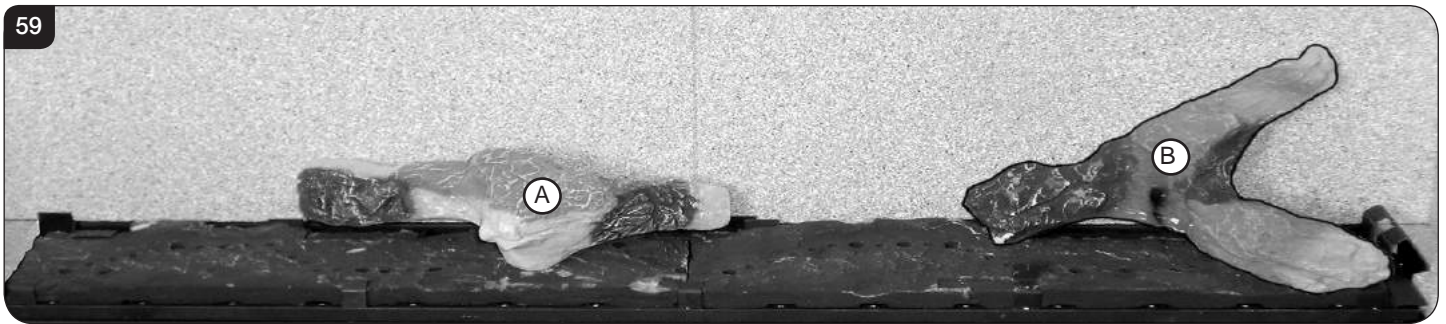

- 12.5 Rest the left end of Log C on the bottom left vermiculite panel in the back left corner, see Diagram 60. The right end of Log C rests across Log A with the small front branch resting on the burner tray.

- 12.6 Engage the left hand end of Log D with the right hand end of Log A. The right hand end of Log D fits in front of the metal stop on the front of the burner tray.

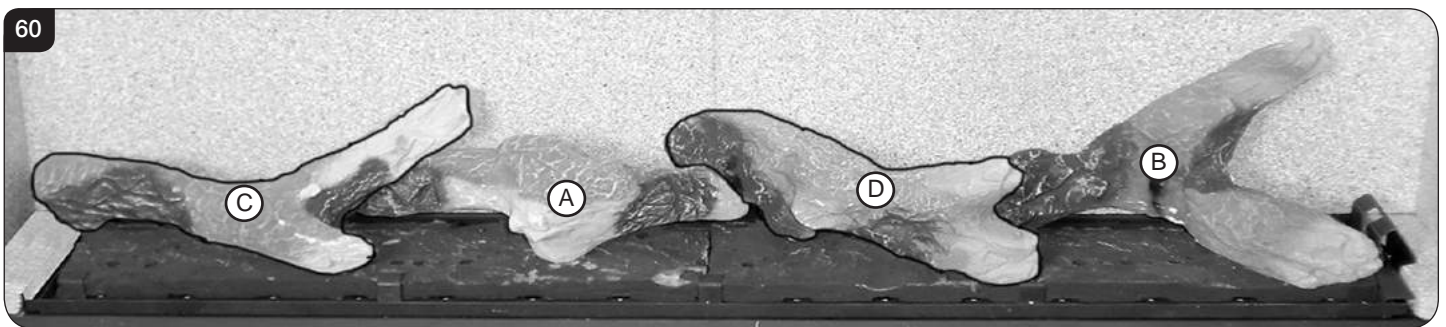

- 12.7 Separate the Embaglow material into smaller pieces and pull into shape to create a fine layer.

- 12.8 Place the pieces of Embaglow between the logs in the highlighted areas shown in Diagram 61. Ensure the material is placed loosely between the logs to create a random glow.

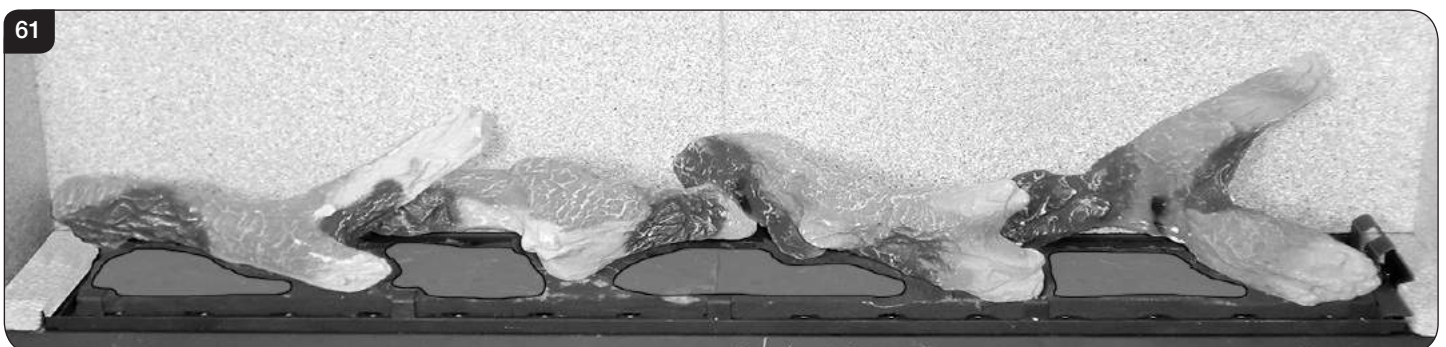

Installation Instructions

Studio 2 Layout

12.9 Ensure the burner tray is clean and free from any debris.

12.10 All logs can be identified by a letter (A , B, C, 2 x D, E) on their underside.

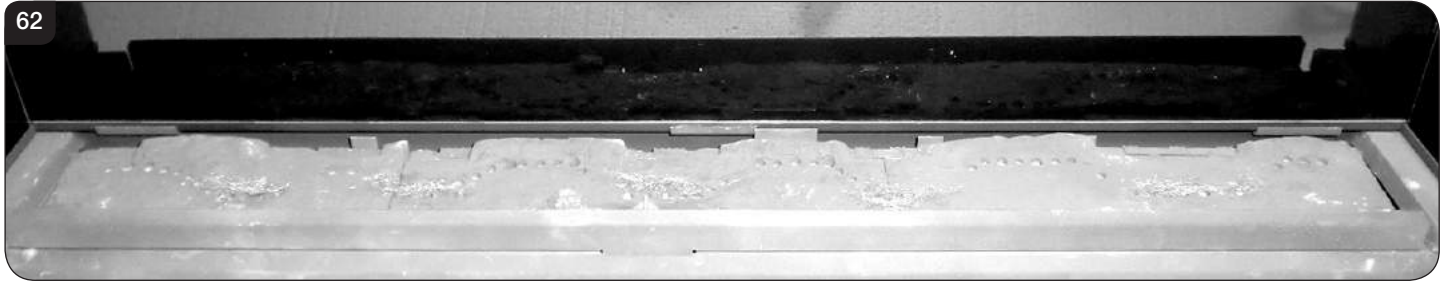

12.11 Position Log A between the two tabs at the back of the burner tray, see Diagram 63. Ensure that it is pushed up against the back panel and the end of Log A is on the raised section of the burner.

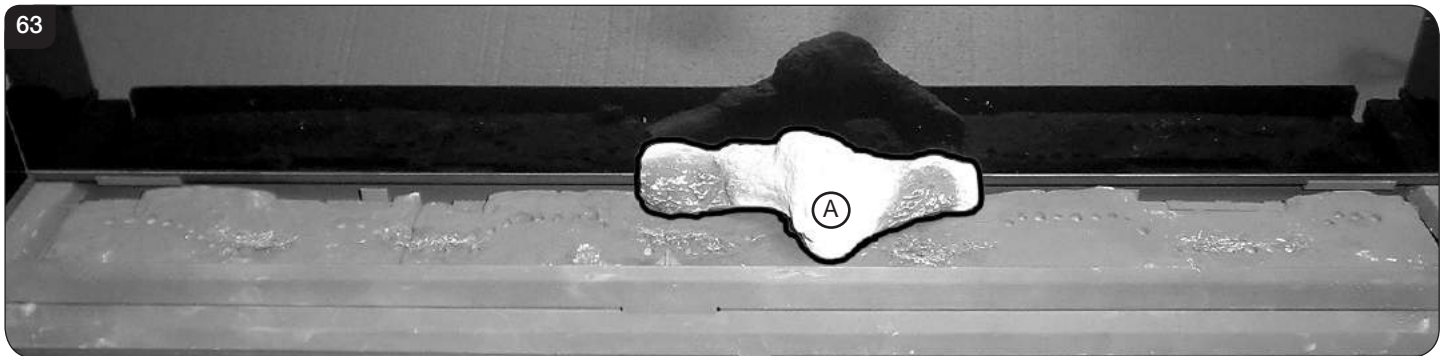

12.12 Place the left hand end of Log B against the back right tab on the burner tray, see Diagram 64. Ensure that the front branch is in line with the front of the burner tray.

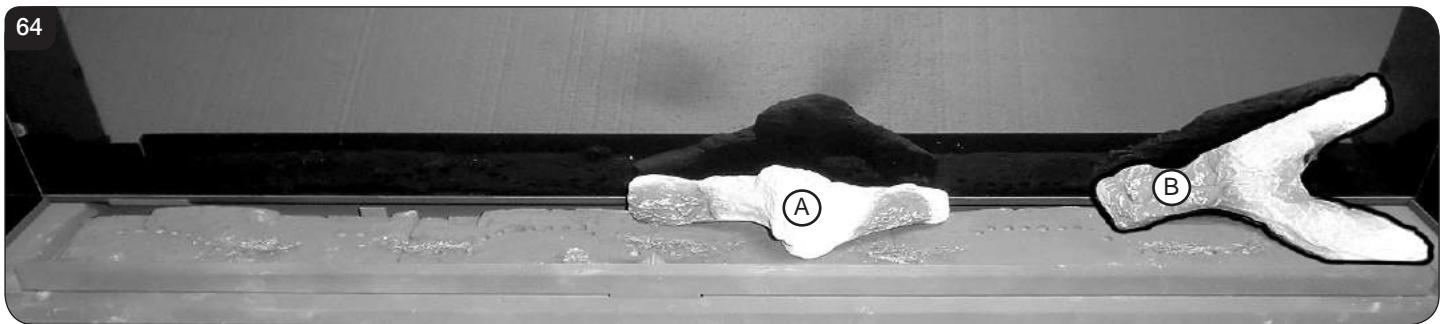

12.13 Rest the left end of Log D on the bottom left vermiculite panel in the back left corner, see Diagram 65. The right end of Log D should be touching the rear liner.

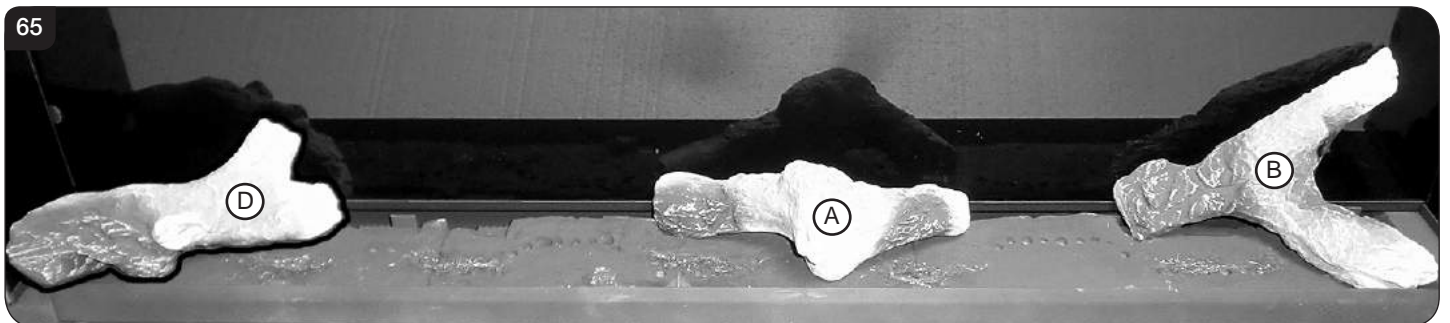

Installation Instructions

12.14 Engage the left hand end of Log D with the right hand end of Log A.
The right hand end of Log D fits in front of the metal stop on the front of the burner tray.

12.15 Place the left hand side of Log C to the rear of the burner tray against the tab and the right hand side at the front of the burner with the rear section resting on Log A.

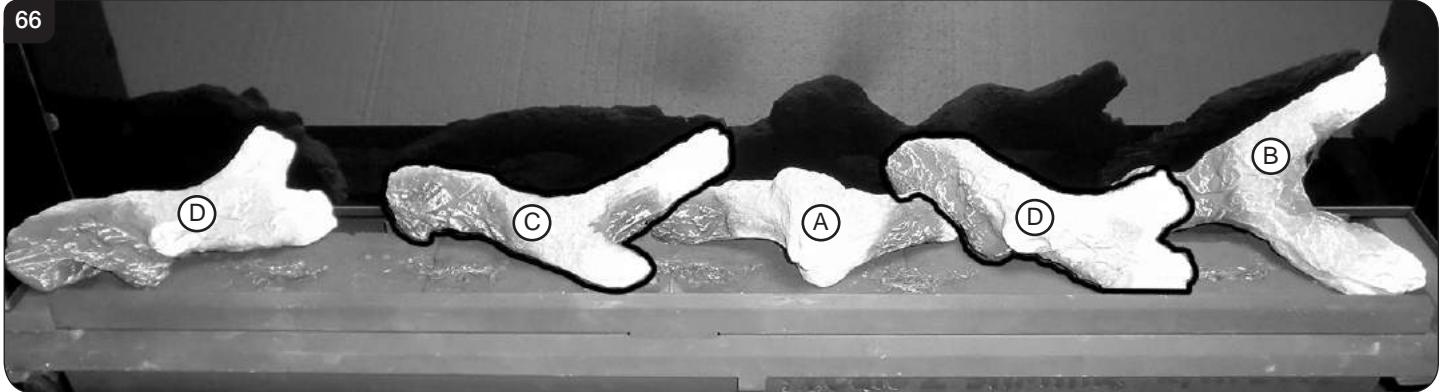

12.16 Log E rests against logs C and D with the lower end located in the cutout in the burner, see Diagram 67.

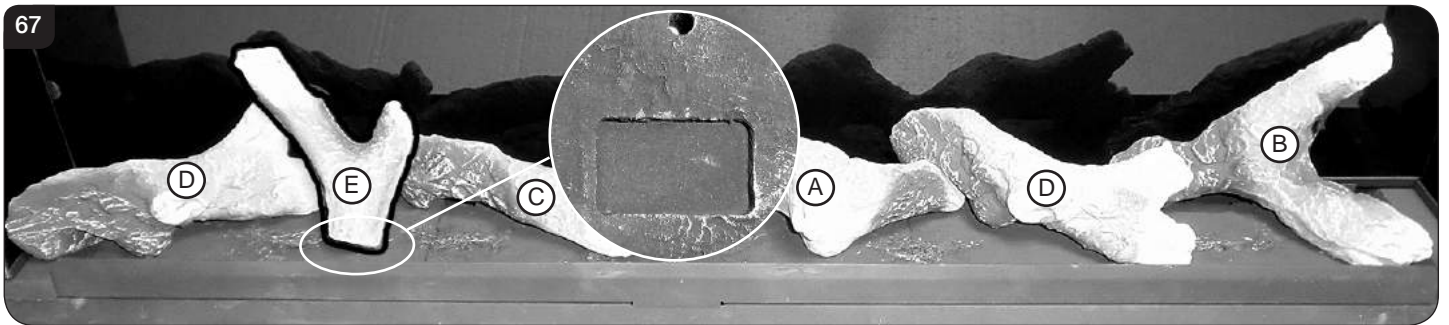

12.17 Separate the Embaglow material into smaller pieces and pull into shape to create a fine layer.

12.18 Place the pieces of Embaglow between the logs in the highlighted areas shown in Diagram 68. Ensure the material is placed loosely between the logs to create a random glow.

IMPORTANT EMBAGLOW MUST BE KEPT AWAY FROM THE PILOT.



Installation Instructions

13. Stone/ Glass Fuel Effect Layout

- 13.1 To use the white stone or glass granule fuel effect, apply according to the following instructions to give the correct flame effect.
- 13.2 Ensure the burner tray is clean and free from any debris, see Diagram 69.



- 13.3 Fill the tray making sure the effect is flattened so it is level with the rim of the tray. **DO NOT OVERFILL THE BURNER TRAY.**
TAKE CARE NOT TO SPILL EFFECT INTO THE PILOT AREA FRONT CHANNEL OR GAP AT REAR OF TRAY (ALL MODELS) AND THE DIVIDING AIR CHANNEL (STUDIO 2 ONLY) see Diagram 70 & 71.
ONLY GENUINE GAZCO PARTS CAN BE USED IN THIS APPLIANCE.

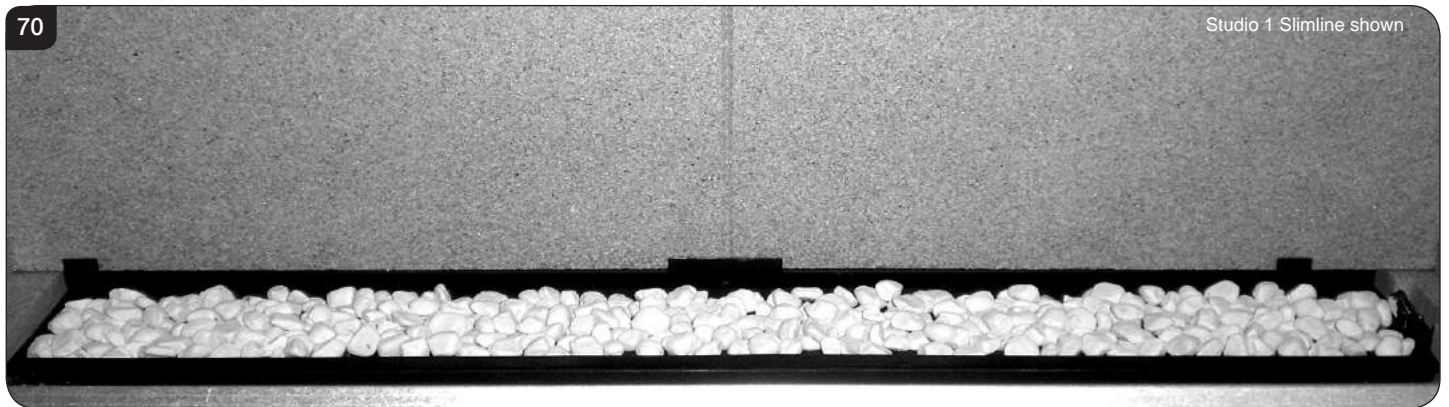

Installation Instructions

14. Completion of assembly

- 14.1 To fit the window frame keep the frame in the upright position with the locks uppermost.
- 14.2 Offer the frame to the foot of the opening.
- 14.3 Slide the frame to the right to locate the right hinge pin.
- 14.4 Manoeuvre the frame up towards the left side to locate the middle and left hinge pins.
- 14.5 Slide onto the hinge with a right movement.
- 14.6 Secure in place with a spring clip at the right hinge pin, see Diagram 72.

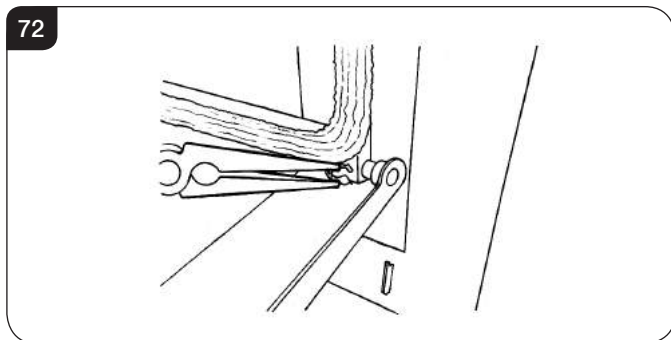

- 14.7 Close the window.
- 14.8 Using the hexagon key provided close the window locks by moving from open to shut towards the window centre, see Diagram 73.

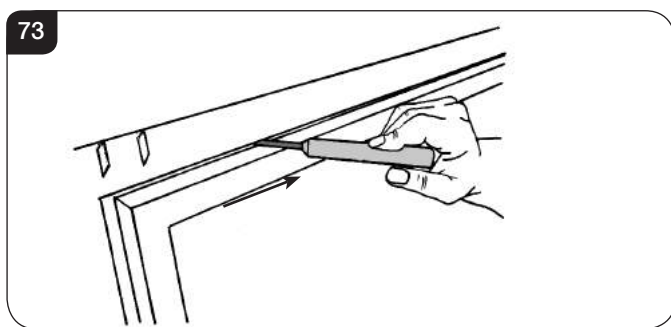

- 14.9 When closing the door ensure the door catches are fully engaged.

! UNDER NO CIRCUMSTANCES SHOULD THE APPLIANCE BE USED WITHOUT THE CATCHES HOLDING THE DOOR IN PLACE.

15. Lighting the Appliance

The appliance is operated by thermostatic remote control.

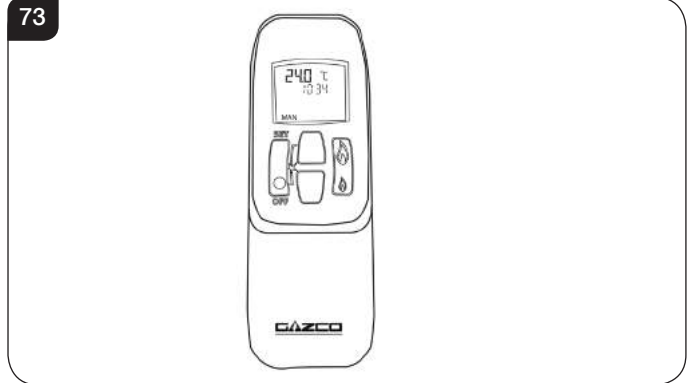

This remote controls the appliance from pilot ignition through to shut down.

In 'MANUAL MODE' you can:

- light the pilot.
- turn on the main burner.
- regulate the flame from low to high and back.
- turn off the burner leaving just the pilot burning.

In 'TEMP MODE' you can:

- set the room temperature so the stove automatically maintains that temperature.

In 'TIMER MODE' the fire:

- turns on and off according to the set time periods.
- automatically regulates the room temperature during the set periods.

15.1 Turning the appliance On

Your remote can control the gas fire from pilot ignition through to shut down.

To turn the fire on press the OFF button and the UP button simultaneously. You hear several short signals.

The pilot and main burner ignite and the remote is now in Manual Mode:

Turning the appliance Off:

Press the OFF button to turn the appliance off
FOR SAFETY, YOU MUST WAIT 30 SECONDS BEFORE LIGHTING THE FIRE AGAIN.

i IMPORTANT: YELLOW FLAMES TYPICALLY APPEAR WHEN THE APPLIANCE HAS REACHED NORMAL OPERATING TEMPERATURE. THIS CAN TAKE UP TO 30 MINUTES.

! WARNING: IF THE APPLIANCE FAILS TO LIGHT OR BECOMES EXTINGUISHED IN USE, WAIT 3 MINUTES BEFORE ATTEMPTING TO RELIGHT.

FOR FULL OPERATING INSTRUCTIONS AND TROUBLESHOOTING SEE USER SECTION.

Commissioning

1. Commissioning

- 1.1 Complete the Commissioning Checklist at the front of this manual covering:
- Flue checks
 - Gas checks
 - Log layout - flame picture
- For working pressure test, use the access panel at the gas connection ensuring the burner is in position. Refer to Replacement Parts, Section 16.
- 1.2 Ensure all safety checks listed in the Commissioning Section are completed, paying particular attention to the glass panel checks and securing of the glass frame.
- 1.3 Upon completion of the commissioning and testing of the installation and correct operation of the appliance, the installer must instruct the user how to operate the appliance.
- 1.4 Guide the user through the User Instructions paying particular attention to:
- a) Regular servicing (Section 10 of the User Instructions).
 - b) Ventilation (Section 11 of the User Instructions) - point out the ventilation positions where applicable.
 - c) Hot surfaces (Section 13 of the User Instructions).
 - d) How the appliance works with the remote control handset and the modes of operation (Section 2 of the User Instructions).
 - e) How to change settings in the auto mode and program modes of operation.
 - f) What to do if the appliance fails to operate (Section 14 of the User Instructions).

Reprogramming handset/Control box

To access the control box see Servicing Instructions, Section 7 - Main Control Assembly.

- Press and hold the reset button on the control box until you hear two signals. After the second longer signal:
- Release the reset button and within 20 seconds:
- Press the DOWN button on the handset until you hear two additional short signals confirming the new code is set. If there is a single long signal the code learning sequence has failed or the wiring is incorrect.

Servicing Instructions

Servicing/Fault Finding Charts

1. Servicing Requirements

IMPORTANT – The glass panel on this appliance should be checked for any signs of damage on the front face of the glass panel (scratches, scores, cracks or other surface defects). If damage is observed, the glass panel must be replaced and the appliance must not be used until a replacement is installed. Under no circumstances should the appliance be used if any damage is observed. Please isolate the appliance until a replacement glass panel has been obtained and installed. Replacement glass panels can be purchased from Gazco via the retailer from which the appliance was purchased or any other Gazco distributor.

This appliance must be serviced at least once a year by a competent person.

All tests must be carried out in accordance with the current Gas Safe recommendations.

1.1 Before Testing:

- Conduct a gas soundness test for the property ensuring there are no leaks before servicing.
- Check the operation of the appliance before testing.

1.2 Special checks:

- Clean the burner using a vacuum cleaner with a soft brush attachment. Ensure all debris is removed from the burner ports.

- Clean away lint or fluff from the pilot.
- Clean away lint or fluff from under the burner.
- Check the spark gap on the pilot is correct.

1.3 Correct any faults found during the initial test.

1.4 Re-commission the appliance in accordance with Commissioning Procedures of these instructions.

1.5 Advise the customer of any remedial work undertaken.

REPLACE BATTERIES BEFORE ATTEMPTING TO RECTIFY ANY FAULTS.

ELECTRONIC CONTROL VALVE FAULT ANALYSIS

Symptom	Cause	Remedy
3 Short beeps from control	Batteries low in appliance	Replace appliance batteries
No ignition, 5 second continuous tone (there may be several short beeps before)	Loose/damaged wire	Check interrupter block and wires
No ignition, no tone, motor turns slightly when operated	Receiver board damaged	Replace receiver
No pilot flame and control continues to spark	Thermocouple circuit wired incorrectly	Correct wiring
Pilot lights, control continues to spark, valve shuts down after 10 - 30 seconds	1. No spark at pilot burner 2. Loose/damaged wire	1. Rectify spark at pilot burner 2. Check interrupter and wires

IGNITION FUNCTIONAL CHECK 1

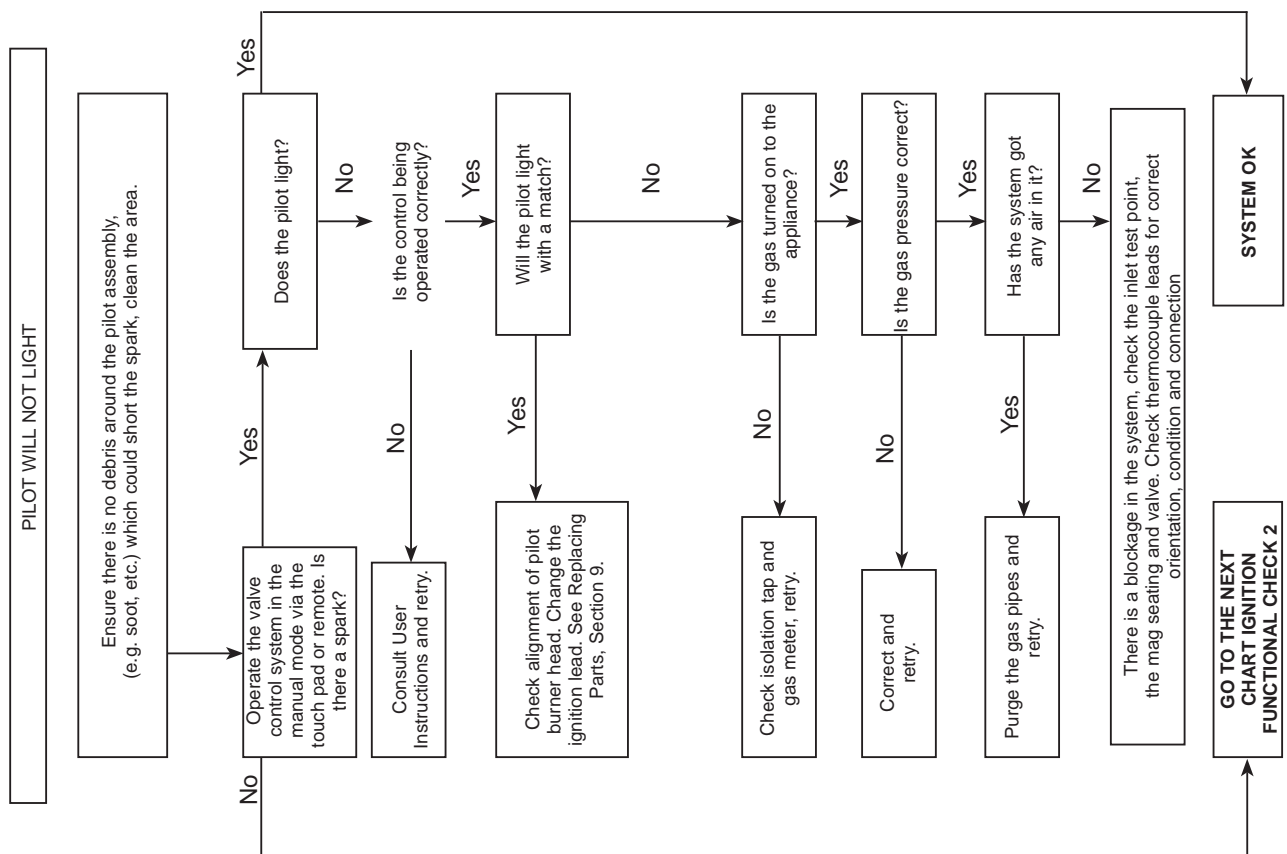

Servicing Instructions

Fault Finding Charts

FLAME FAILURE FUNCTIONAL CHECK 3

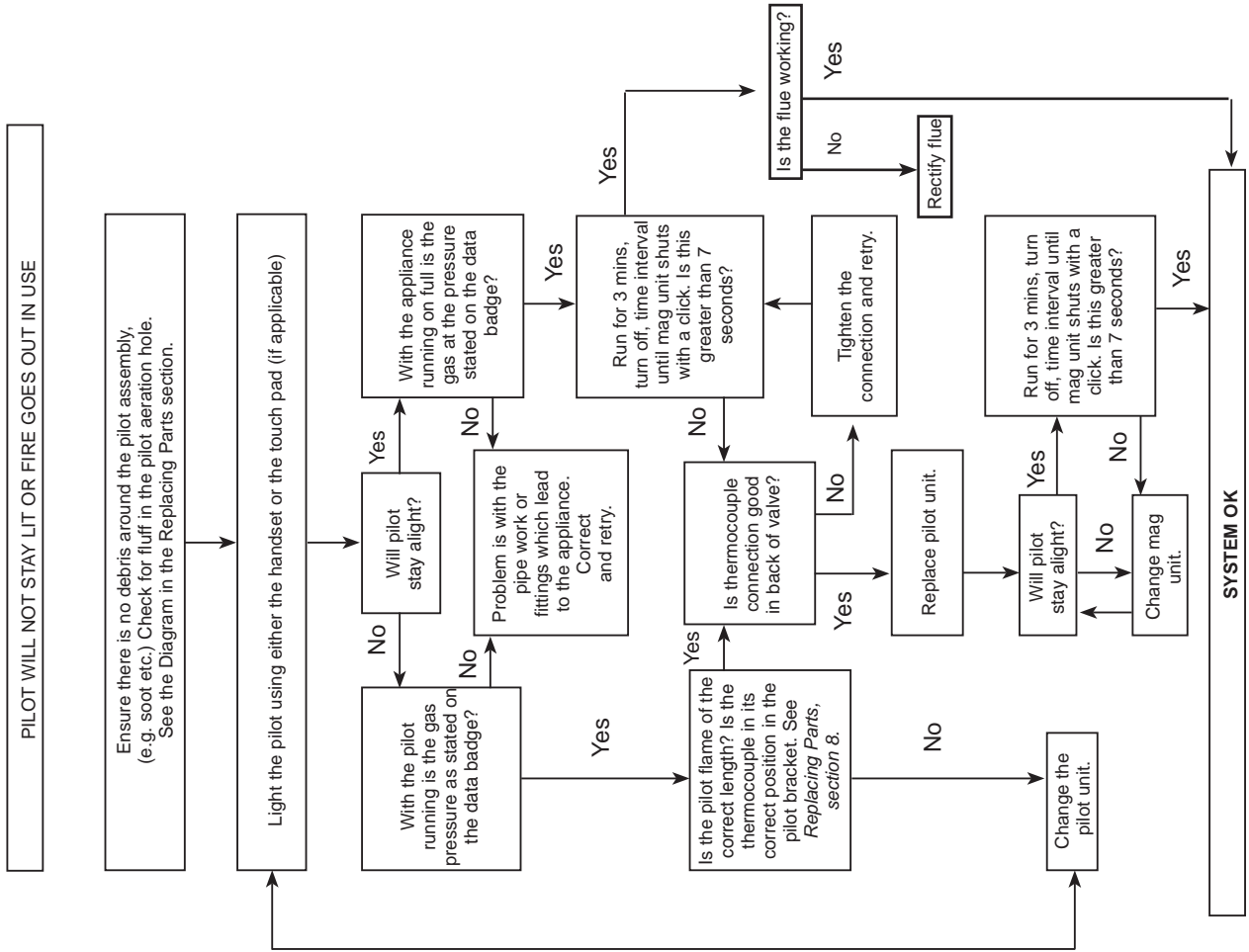

IGNITION FUNCTIONAL CHECK 2

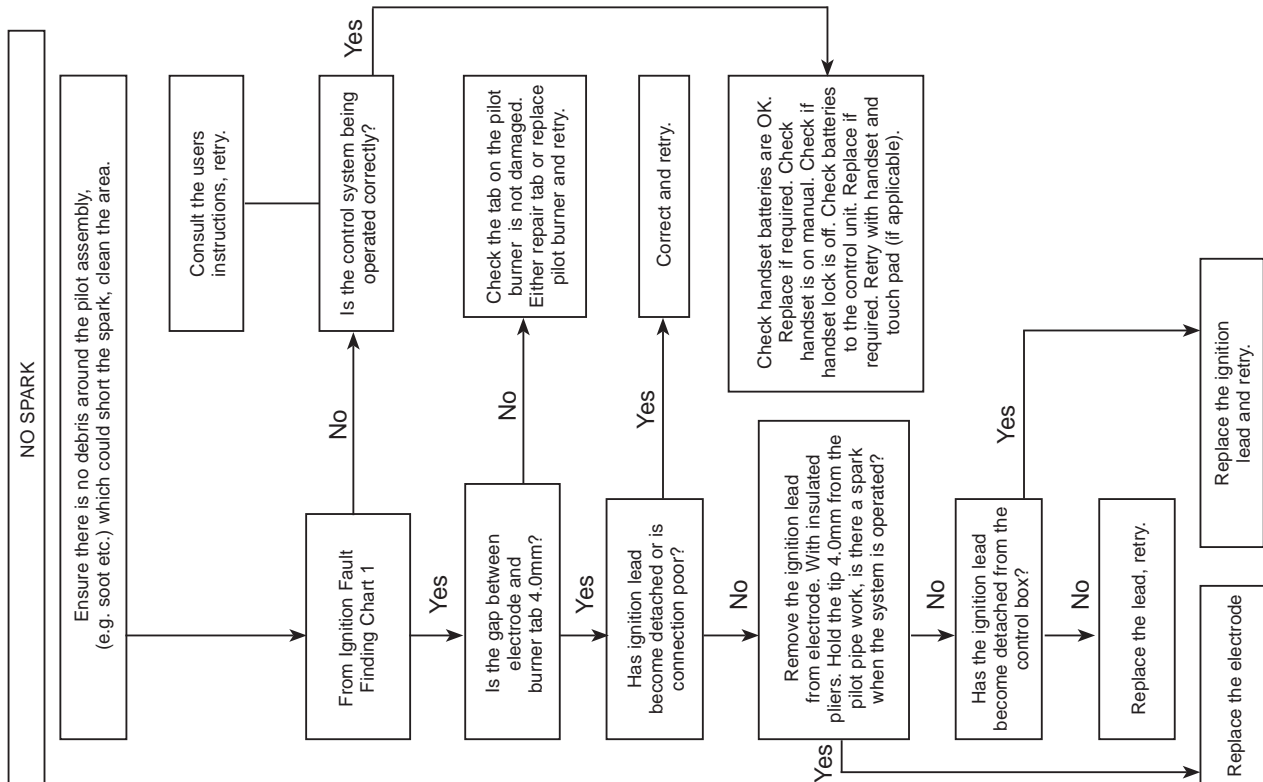

Servicing Instructions - Replacing Parts

1. General

- 1.1 All main components can be replaced without removing the appliance from its installation.

IT IS ESSENTIAL THAT THE GAS SUPPLY TO THE APPLIANCE IS TURNED OFF AT THE ISOLATION DEVICE BEFORE PROCEEDING FURTHER.

- 1.2 **DISCONNECT BATTERIES BEFORE SERVICING THE APPLIANCE.**

Removal of Flue

- 1.3 **If, for any reason, the flue has to be removed from the appliance, the seal must be replaced in the inner spigot.**
- 1.4 Access to the controls is restricted and the whole control assembly must be removed as one unit, see Section 8.

2. Decorative Frame

The same method is used to remove each frame.

- 2.1 Lift the frame upwards off the four support brackets, see Diagram 1.

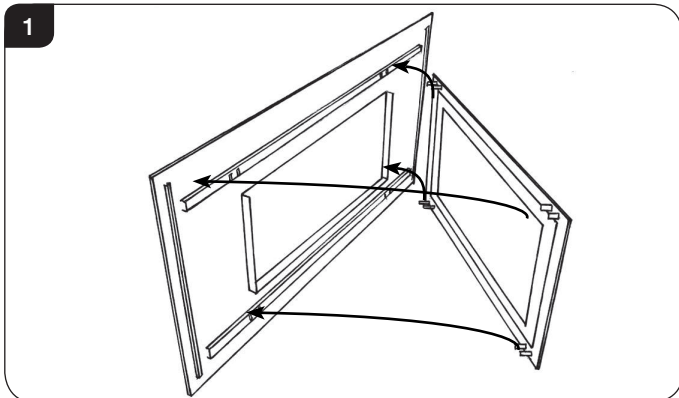

NOTE: THE STEEL FRAME IS HEAVY. TAKE CARE WHEN LIFTING.

3. Window Frame Assembly

- 3.1 To open the glass door use the hexagon key provided.
- 3.2 Release the window locks by moving them from shut to open towards the outer edges, see Diagram 2.

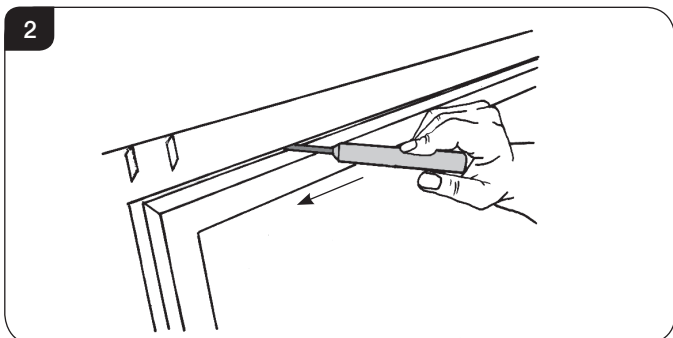

To completely remove the glass front:

- 3.3 Remove the securing spring clip from the bottom-right of the window frame, see Diagram 3.

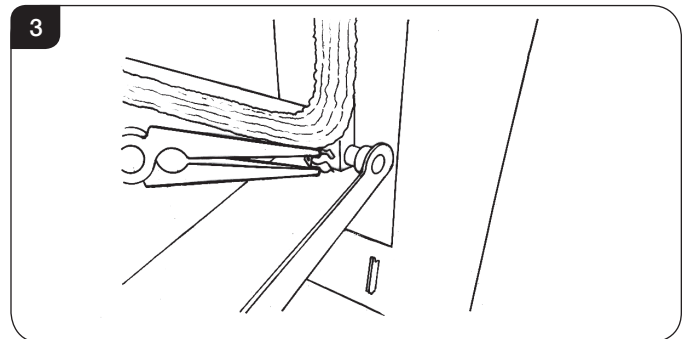

- 3.4 With the window frame in an upright position slide the frame to the left so that it comes off the left hinge pin.

- 3.5 Still keeping the frame upright drop the left side down and forward slightly, see Diagram 4.

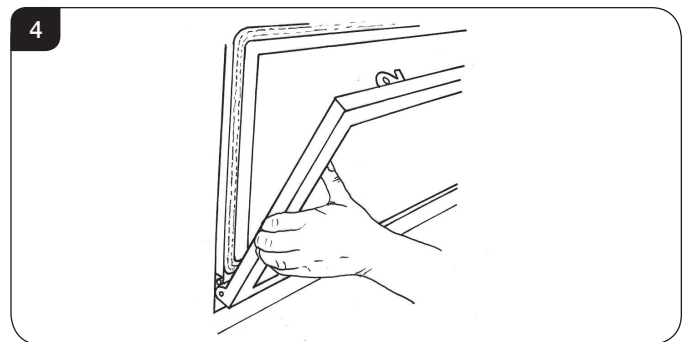

- 3.6 Slide the frame to the right so it comes off the right hinge pin. The window frame should now be free.

- 3.7 Refit in reverse order.

- 3.8 **When closing the door ensure the door catches are fully engaged.**



UNDER NO CIRCUMSTANCES SHOULD THE APPLIANCE BE USED WITHOUT THE CATCHES HOLDING THE DOOR IN PLACE.

Servicing Instructions - Replacing Parts

4. Glass Window

- 4.1 Remove the two clips and brackets from either side of the frame, see Diagram 5.

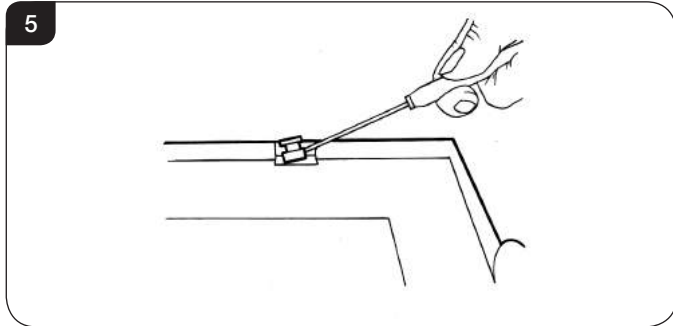

- 4.2 Lift the glass clear from the lock bracket at the top of the frame and slide out.

5. Removal & Fitting of the Liners

- 5.1 The Slimline Studio appliance comes with 3 optional liner finishes:

Vermiculite
Black Reeded
Brick Effect

- 5.2 Slide the two side liners forward until clear of the appliance, see Diagram 6.

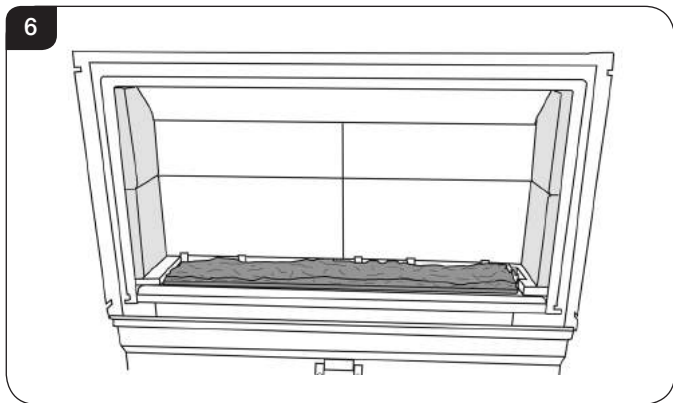

- 5.3 Remove the two clips holding the back panel in place, see Diagram 7.

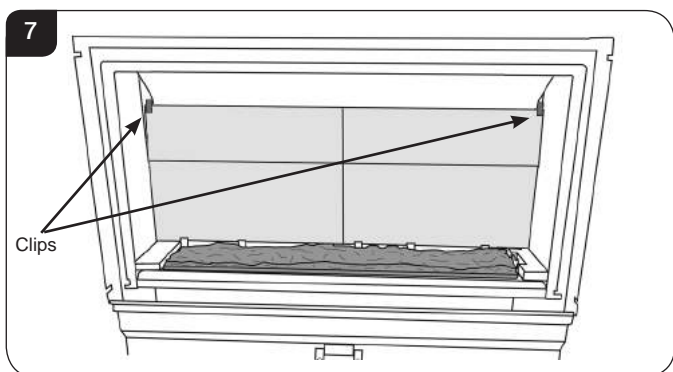

- 5.4 Remove the back panel then the two Bottom Side Liners, see Diagram 8.

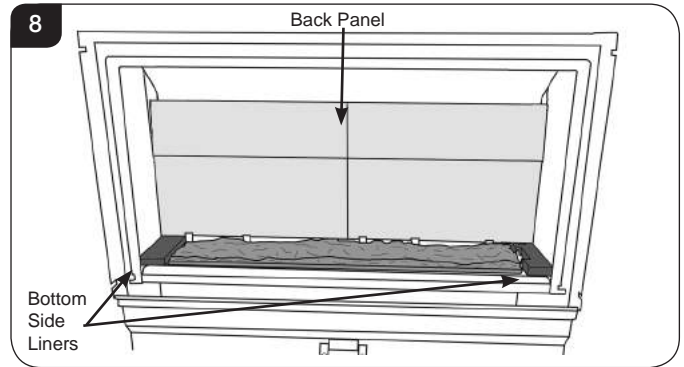

- 5.5 Replace the liners in reverse order.

6. Main Burner

To replace the main burner:

- 6.1 Remove the fuel effect from the burner.
6.2 Remove the 3 burner securing screws and clips from the front of the burner, see Diagram 9.
Note: Studio 2 Slimline - only remove the right hand clip next to the pilot bracket.

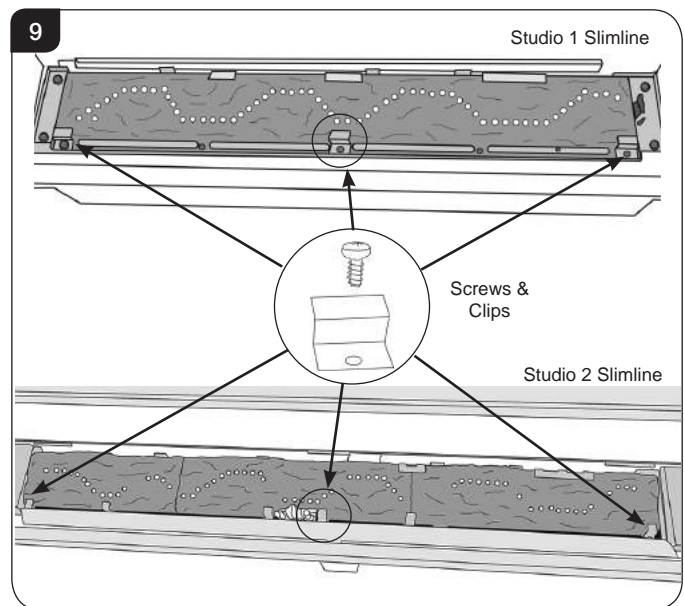

IMPORTANT

When replacing the main burner make sure that the clips are replaced with screws.

- 6.3 Lift the burner up and out of the appliance.
6.4 Refit in reverse order, ensuring the venturi engages with the main injector.
6.5 When refilling the stone chippings, fill to the level of the rim of the burner tray and flatten level.

Ensure no stone chippings fall into the air slots at the front of the burner.

Servicing Instructions - Replacing Parts

7. Main Control Assembly

7.1 To access the main control assembly first remove:

- The decorative frame
- Window frame
- Liners
- Main burner

To remove the access panel:

7.2 Undo the two screws, see Diagram 10.

7.3 **Note the orientation of the access panel with the return edges facing forward.**

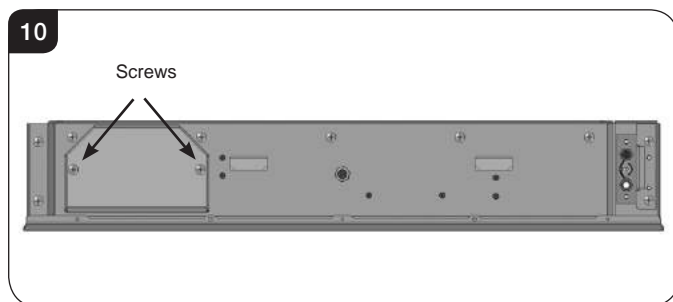

7.4 Isolate the gas supply at the isolation device and disconnect the gas inlet, see Diagram 11.

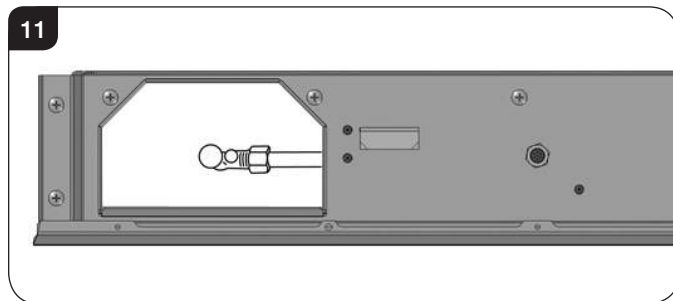

7.5 Remove the 9 (Studio Slimline 1) or 11 (Studio Slimline 2) screws securing the control assembly, see Diagram 12.

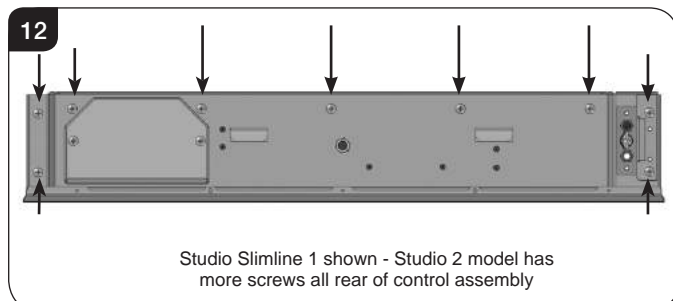

7.6 The control assembly can now be lifted up and out of the appliance.

7.7 Disconnect the battery supply cable from the control unit.

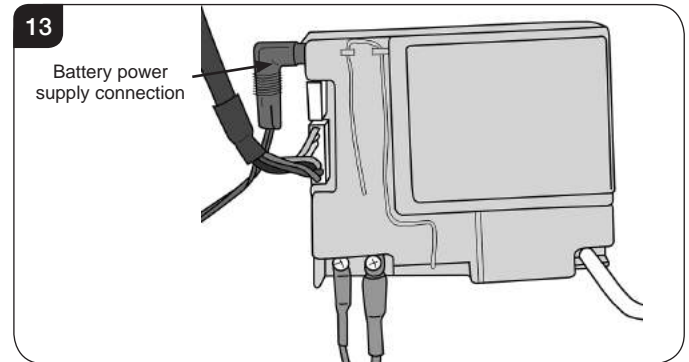

7.8 Reassemble in reverse order.

Note: Ensure no wires are trapped when replacing the assembly and that the foam seal is fully intact.

Replace the front two screws first, finger tight.

IMPORTANT: DO NOT CROSS THREAD.

It may be necessary to place a screwdriver through one of the central holes in order to align the fixing holes.

8. Pilot Unit Assembly

The pilot assembly consists of four components which can be individually changed:

- 8a) Pilot burner bracket.
- 8b) Electode
- 8c) Pilot Injector
- 8d) Thermocouple.

8.1 Before commencing work on the pilot the Main Control Assembly must be removed, see Section 7.

8a Pilot Burner Bracket

To remove the Pilot Burner Bracket:

8.2 **First remove the electrode, pilot pipe and thermocouple see Sections 8b, 8c & 8d.**

8.3 Remove the two screws securing the bracket. The pilot burner bracket can now be removed.

8.4 Check the pilot gasket and if damaged, replace with a new one.

8.5 Replace in reverse order.

Servicing Instructions - Replacing Parts

8b Electrode

- 8.6 Pull the ignition lead off the electrode and undo the retaining nut, see Diagram 14.

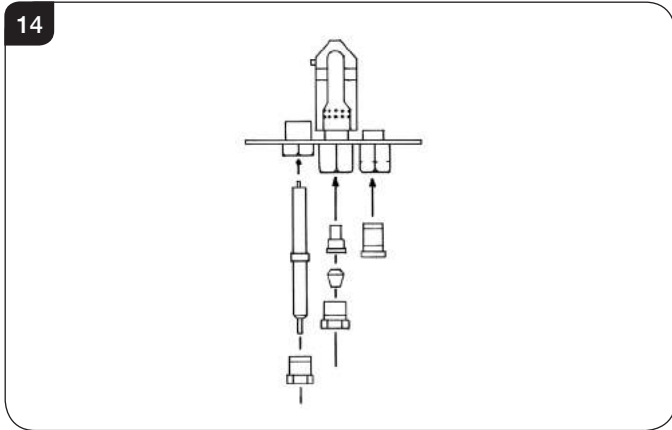

- 8.7 Replace with a new electrode. Do not over-tighten the nut; this could break the component.
- 8.8 Replace the ignition lead.

8c Pilot Injector

- 8.9 Undo the pilot pipe from the gas valve and from the underside of the pilot burner, see Diagram 15.

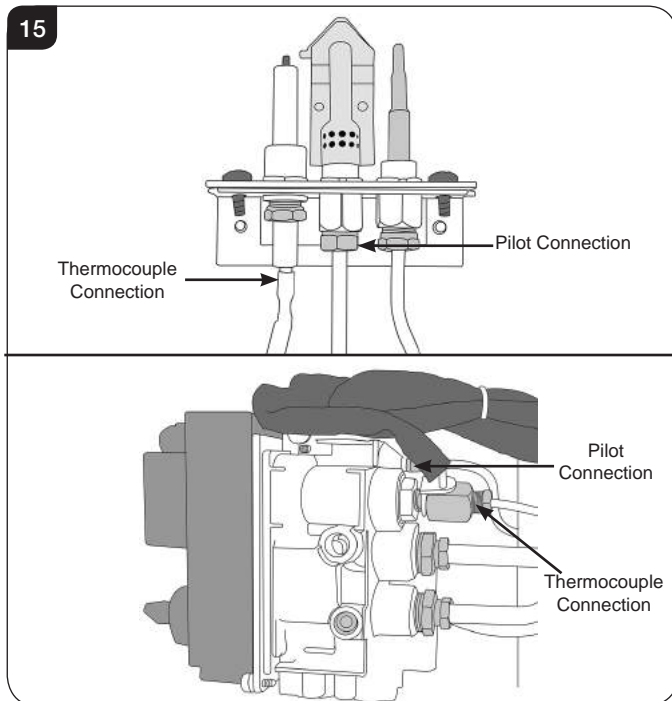

- 8.10 Remove the pipe and the injector drops out from the burner.

8d Thermocouple

- 8.11 Disconnect the thermocouple from the gas valve/interrupter, see Diagram 15.
- 8.12 Note the position of the interrupter leads. The lead with the blue tag **MUST** be placed furthest away from the gas valve.
- 8.13 Undo the thermocouple nut in the back of the pilot bracket half a turn, see Diagram 15. This releases the thermocouple.

Studio Slimline 2 only

This model has a U shaped bracket that secures the cables as they pass through the bulkhead. This is held in place by a single screw. Remove the screw and clean away any sealant. The cables can now be withdrawn.

When replacing the cables apply fresh sealant and secure in place with the bracket.

All Models

- 8.14 When replacing with a new thermocouple, take care to bend the new component to the same shape as the thermocouple just removed.
- 8.15 To refit the thermocouple into the pilot bracket, ensure it is pushed fully into the hole. There is a stop on the thermocouple to set the height.
- 8.16 Lock the retaining nut just enough to grip the thermocouple.
- 8.17 Connect the thermocouple to the valve/interrupter **taking care not to over-tighten.**

Servicing Instructions - Replacing Parts

9. Ignition Lead

To replace the ignition lead:

- 9.1 Remove the Main Control Assembly, see Section 7.
- 9.2 Remove the ignition lead from the control box, see Diagram 16.

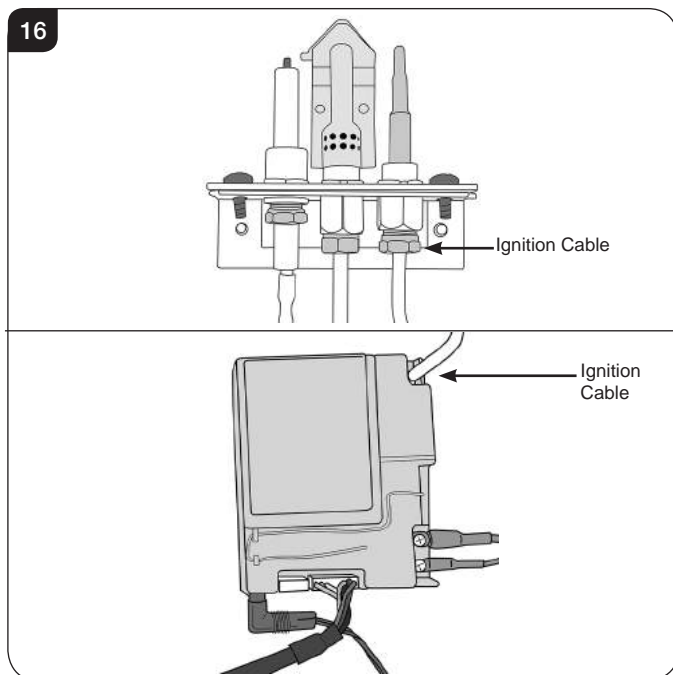

- 9.3 Remove the ignition lead from the electrode, see Diagram 16, remove cable ties where necessary.
- 9.4 **Note the direction of the lead. The new lead must follow exactly the same route. Replace cable ties where necessary.**

10. Gas Valve

To change the gas valve:

- 10.1 Remove the Main Burner, see Section 6.
- 10.2 Release the gas inlet pipe, see Diagram 17, Arrow A.

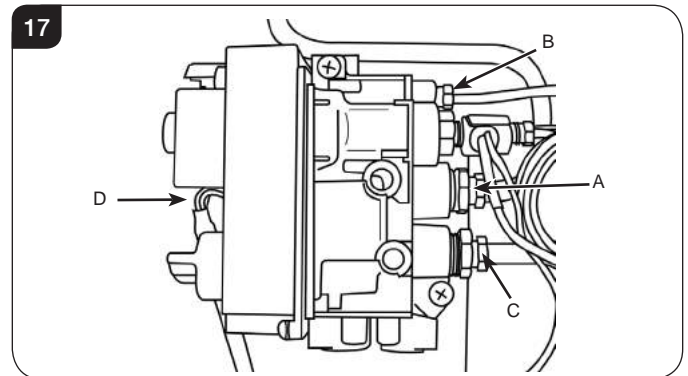

- 10.3 Remove the thermocouple from the interrupter block.
- 10.4 Release the pilot pipe, see Diagram 17, Arrow B.
- 10.5 Release the gas outlet pipe, see Diagram 17, Arrow C.
- 10.6 Remove the eight wire loom, see Diagram 17, Arrow D.
- 10.7 Remove the two screws securing the valve to the support bracket and withdraw the valve.
- 10.8 Replace in reverse order.

11. Magnetic Safety Valve

To replace the magnetic safety valve:

- 11.1 Remove the Main Control Assembly.
- 11.2 Undo the thermocouple from the interrupter block and remove the two interrupter leads.
- 11.3 Unscrew the interrupter block from the back of the valve.
- 11.4 Undo the silver magnetic valve retaining nut on the back of the valve.
- 11.5 Gently tap out the mag valve.
- 11.6 Replace with a new unit.
- 11.7 Reassemble in reverse order ensuring that the interrupter leads are connected correctly with the blue tag lead furthest away from the gas valve body.

Servicing Instructions - Replacing Parts

12. Control Box

- 12.1 To replace the control box first remove the main control assembly, See Section 7.
- 12.2 Remove the two thermocurrent cables by removing the two screws, Diagram 18.
- 12.3 Remove the ignition lead, Diagram 18.
- 12.4 Remove the eight wire loom from the control box.
- 12.5 Remove the battery extension cable, Diagram 18.

The control box can now be replaced.

When replacing the sealing plate on the rear of the control cover use a suitable silicone sealant.

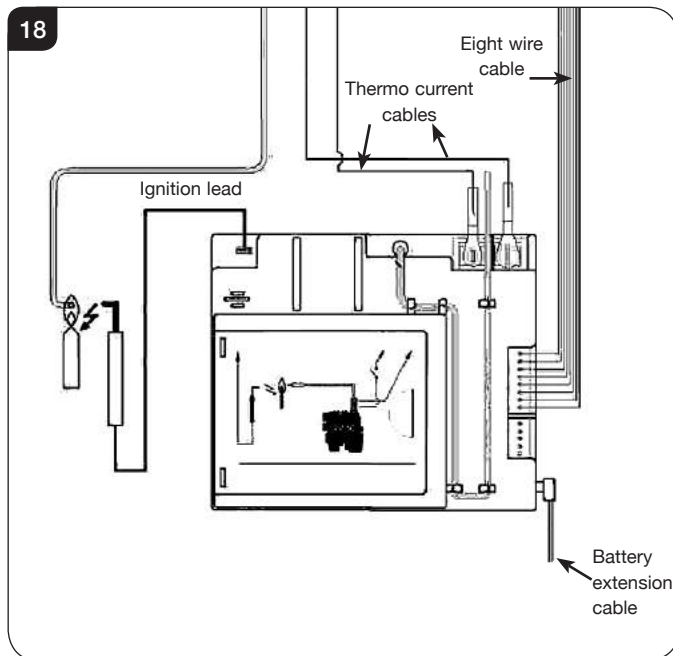

- 12.6 After replacing the control box you may need to reprogram the handset.
 - Press and hold the reset button on the control box until you hear two signals. After the second longer signal:
 - Release the reset button and within 20 seconds:
 - Press the DOWN button on the handset until you hear two additional short signals confirming the new code is set. If there is a single long signal the code learning sequence has failed or the wiring is incorrect.

13. Main Injector

To change the main injector:

- 13.1 Remove the Main Control Assembly.
- 13.2 Undo the injector feed pipe.
- 13.3 Undo the lock nut from the injector.

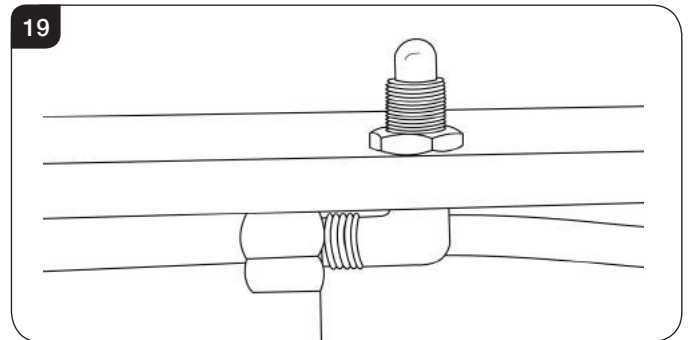

- 13.4 Replace with the correct size injector.

14. Primary Aeration Plate

The Aeration Plate is attached to the main burner unit and can not be replaced individually, see Diagram 20.

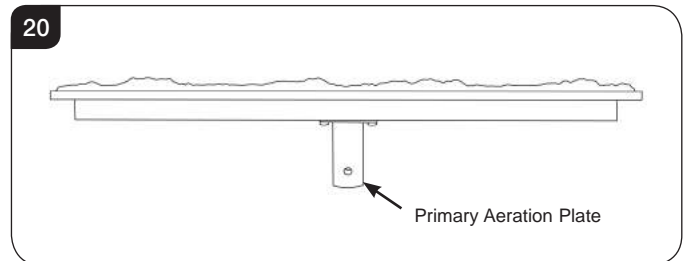

15. Changing Between Gas Types

In order to change between gas types it will be necessary to change both the burner assembly and the complete control assembly.

Contact your Gazco retailer for further information.

A kit of parts is available for this. Always quote the Model number and Serial number when ordering any spare parts.

Servicing Instructions - Replacing Parts

16. Pressure and leak testing the appliance

- 16.1 To gain access to the pressure test point, see Diagram 21 and follow Section 7, Main Control Assembly.

21

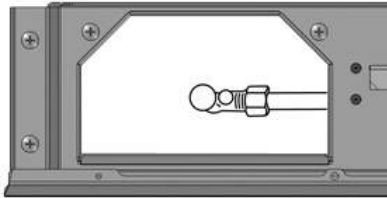

- 16.2 To leak test any gas joints on the appliance the control assembly must be undone and removed, see Section 7.5, Diagram 12.
- 16.3 Because there is now no burner fitted to perform a leak test, place a manometer tube over the injector tip.
- 16.4 Light the appliance and spray any joints with leak detector fluid.
- 16.5 Tighten joints or replace as required.
- 16.6 To check the inlet working pressure, replace the control assembly and connect a manometer to the pressure test point as depicted in Diagram 21.
- 16.7 Replace the burner and relight the appliance.
- 16.8 Operate the appliance at highest flame setting and check that the inlet pressure is in accordance with specifications detailed on pages 11.

Servicing Instructions - Replacing Parts

18. Spare Parts List - Studio Slimline 1

WHITE STONE VERSION

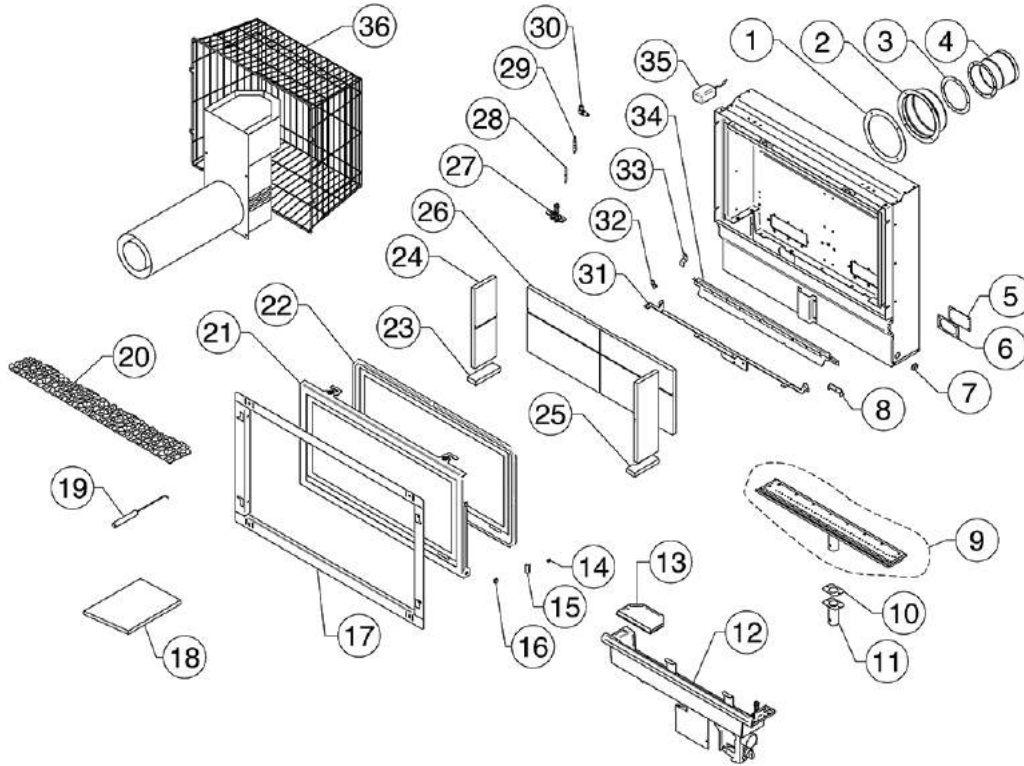

No.	Component	Part Code		Quantity
		Natural Gas	LPG	
1	Outer Flue Gasket	CE0211		1
2	Outer Flue Spigot	MEC0269		1
3	Inner Flue Gasket	CE0210		1
4	Inner Flue Spigot	MEC0275		1
5	Inlet Silicone Seal	FA0354		2
6	Gasket Plate	ME3746		2
7	Grommet	EL0022		2
8	Rear Lining Retaining Bracket	GZ10481		1
9	Burner Assembly	GZ10550	GZ10551	1
10	Venturi Gasket	CE0209		1
11	Venturi Assembly	GZ10579	GZ5217	1
12	Full Control Assembly	GZ11866N	GZ11866P	1
13	Access Hatch Assembly	GZ9914		1
14	Tool Clip	FA0522		1
15	Glass Clip Bracket	GZ6361		2
16	Steel Edge Clip	FA0523		2
17	Installation Frame Assembly	GZ9892		1
18	Instruction Fixing Kit	GZ11923		Kit
19	Door Tool	GZ6690		1
20	White Stones	CE1094		1
21	Door Assembly	GZ10488		1
22	Glass & Rope Seal Assembly	GZ10549		1

No.	Component	Part Code		Quantity
		Natural Gas	LPG	
23	LH Base - Vermiculite	CE1076		1
23	LH Base - Black Reed	CE1198		1
23	LH Base - Brick Effect	CE1198		1
24	Side Lining LH & RH Vermiculite	CE1075		2
24	Side Lining LH & RH Black Reed	CE1205		2
24	Side Lining LH & RH Brick Effect	CE1197		2
25	RH Base - Vermiculite	CE1077		1
25	RH Base - Black Reed	CE1199		1
25	RH Base - Brick Effect	CE1199		1
26	Rear Lining - Vermiculite	CE1074		1
26	Rear Lining - Black Reed	CE1204		1
26	Rear Lining - Brick Effect	CE1196		1
27	Pilot	PI0069		1
28	Electrode	PI0075		1
29	Thermocouple	PI0074		1
30	Injector - Size 170	IN0053		1
31	Top Baffle	GZ9880		1
32	Rear Lining Restraint Bracket	GZ10521		2
33	Upper Lining Restraint Bracket	GZ10786		2
34	Rear Lining Support Bracket	GZ9923		1
35	Mains Adaptor - Mertik	999-620		1
36	Rear Exit BF Termination Kit	8526		1

Servicing Instructions - Replacing Parts

18. Spare Parts List - Studio Slimline 1

LOG VERSION

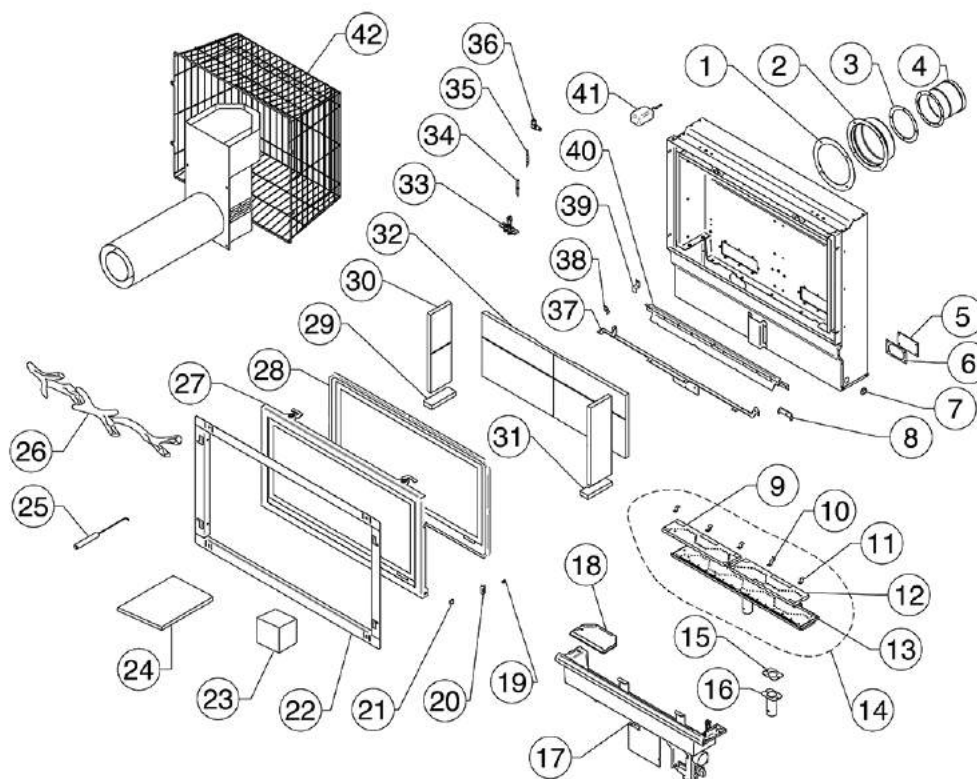

No.	Component	Part Code		Quantity
		Natural Gas	LPG	
1	Outer Flue Gasket	CE0211		1
2	Outer Flue Spigot	MEC0269		1
3	Inner Flue Gasket	CE0210	GZ7452	1
4	Inner Flue Spigot	MEC0275		1
5	Inlet Silicone Seal	FA0354		2
6	Gasket Plate	ME3746	GZ7702	2
7	Grommet	EL0022		2
8	Rear Lining Retain Bracket	GZ10481		1
9	LH Plaque	CE1192	CE1194	1
10	Log Support Clip	GZ10576		1
11	Burner Fuel Bed Clamp	GZ10522		1
12	RH Plaque	CE1193	CE1195	1
13	Full Burner Assembly	GZ9867	GZ10524	2
14	Complete Burner Assembly	GZ10991	GZ10992	2
15	Venturi Gasket	CE0209		1
16	Venturi Assembly	GZ10578	GZ5217	1
17	Full Control Assembly	GZ11866N	GZ11866P	1
18	Access Hatch Assembly	GZ9914		1
19	Tool Clip	FA0522		1
20	Glass Clip Bracket	GZ6361		2
21	Steel Edge Clip	FA0522		2
22	Installation Frame Assembly	GZ9892		1
23	Embaglow	GZ8471		1
24	Instruction Fixing Kit	GZ11923		Kit
25	Door Tool	GZ6690		1

No.	Component	Part Code		Quantity
		Natural Gas	LPG	
26	Log Set	CE1187		1
27	Door Assembly	GZ10488		1
28	Glass and Rope Seal Assembly	GZ10549		1
29	LH Base - Vermiculite	CE1076		1
29	LH Base - Black Reed	CE1198		1
29	LH Base - Brick Effect	CE1198		1
30	Side Lining RH & LH - Vermiculite	CE1075		2
30	Side Lining RH & LH - Black Reed	CE1205		2
30	Side Lining - Brick Effect	CE1197		2
31	RH Base - Black Reed	CE1199		1
31	RH Base - Vermiculite	CE1077		1
31	RH Base - Brick Effect	CE1199		1
32	Rear Lining - Black Reed	CE1204		1
32	Rear Lining - Vermiculite	CE1074		1
32	Rear Lining - Brick Effect	CE1196		1
33	Pilot	PI0069	PI0070	1
34	Electrode	PI0075		1
35	Thermocouple	PI0074		1
36	Injector	IN0053 - Size 170	IN0031 - Size 150	1
37	Top Baffle	GZ9880		1
38	Rear Lining Restraint Bracket	GZ10521		2
39	Upper Lining Restraint Bracket	GZ10786		2
40	Rear Lining Support Bracket	GZ9923		1
41	Mains Adaptor- Mertik	999-620		1
42	Rear Exit Termination Kit	8526		1

Servicing Instructions - Replacing Parts

18. Spare Parts List - Studio Slimline 2

WHITE STONE VERSION

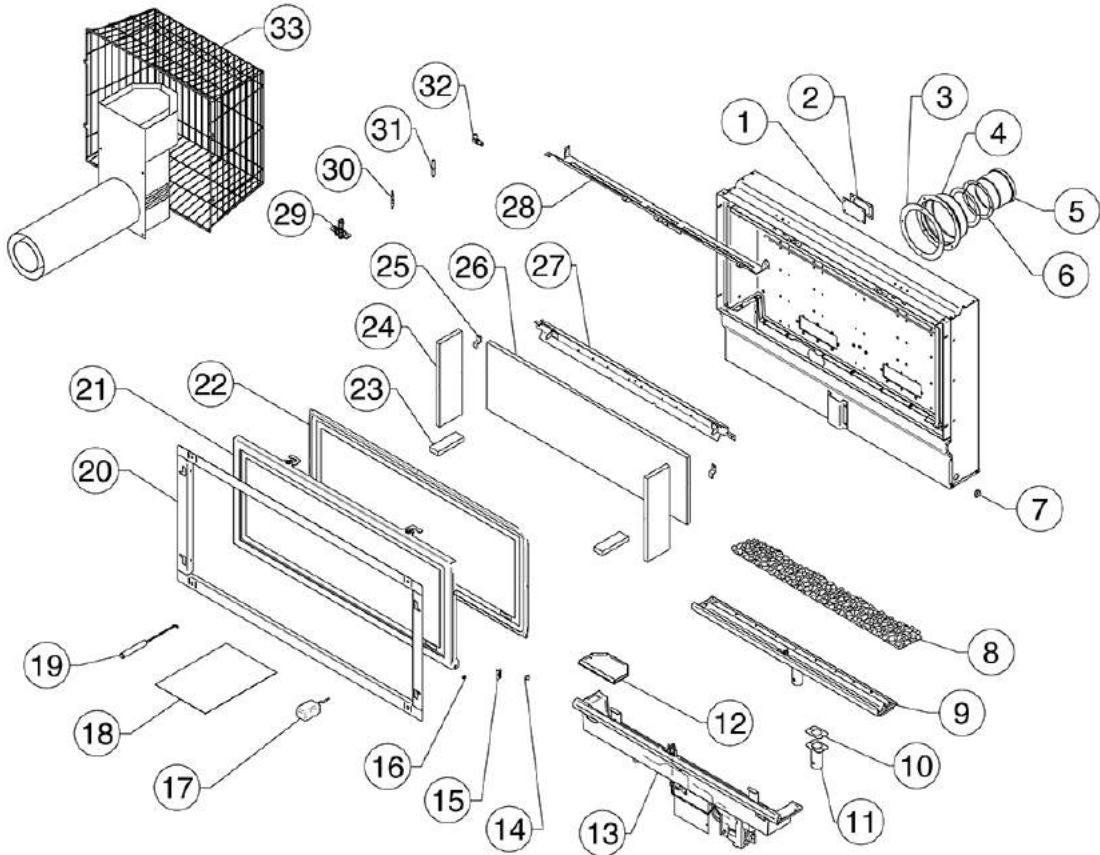

No.	Component	Part Code		Quantity
		Natural Gas	LPG	
1	Silicone Seal	FA0354		2
2	Gasket Plate	ME3746		2
3	Outer Flue Spigot Gasket	CE0211		1
4	Outer Flue Spigot	MEC0269		1
5	Inner Flue Spigot	MEC0275		1
6	Inner Flue Spigot Gasket	CE0210		1
7	Grommet	EL0022		2
8	White Stones	CE1094		1
9	Burner Assembly	GZ12137		1
10	Venturi Gasket	CE0209		1
11	Venturi	GZ10578		1
12	Access Hatch Assembly	GZ9914		1
13	Full Control Assembly	GZ11916		1
14	Steel Edge Clip	FA0523		1
15	Glass Clip Assembly	GZ6361		1
16	Tool Clip	FA0522		1
17	Mains Adapter	999-620		1
18	Instructions/Fixing Kit	GZ11923		1
19	Door Tool	GZ6690		1

No.	Component	Part Code		Quantity
		Natural Gas	LPG	
20	Installation Frame	GZ11647		1
21	Door Assembly	GZ11650		1
22	Glass Assembly	GZ7353		1
23	Base Side Piece - Black Reed & Brick Effect	CE1198		2
23	Base Side Piece - Vermiculite	CE1076		2
24	Side Lining LH & RH - Black Reed	CE1205		2
24	Side Lining LH & RH - Brick Effect	CE1197		2
24	Side Lining LH & RH - Vermiculite	CE1075		2
25	Lining Restraint Bracket	GZ10786		2
26	Rear Lining - Black Reed	CE1464		1
26	Rear Lining - Brick Effect	CE1466		1
26	Rear Lining - Vermiculite	CE1465		1
27	Rear Lining Support Bracket	GZ11645		1
28	Top Baffle	GZ11661		1
29	Pilot	PI0069		1
30	Thermocouple	PI0074		1
31	Electrode	PI0075		1
32	Injector - Size 184	IN0061		1
33	Rear Exit BF Termination Kit	8526		1

Servicing Instructions - Replacing Parts

18. Spare Parts List - Studio Slimline 2

LOG VERSION

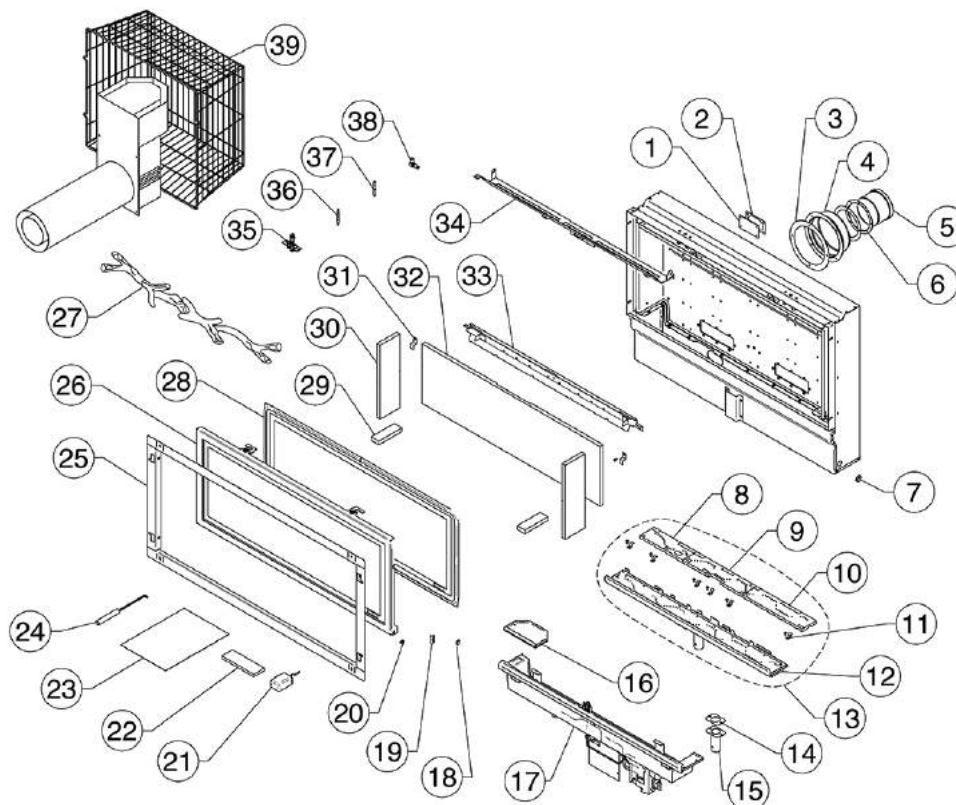

No.	Component	Part Code		Quantity
		Natural Gas	LPG	
1	Silicone Seal	FA0354		2
2	Gasket Plate	ME3746		2
3	Outer Flue Spigot Gasket	CE0211		1
4	Outer Flue Spigot	MEC0269		1
5	Inner Flue Spigot	MEC0275		1
6	Inner Flue Spigot Gasket	CE0210		1
7	Grommet	EL0022		2
8	LH Ceramic Plaque	CE1467		1
9	Centre Ceramic Plaque	CE1416		
10	RH Ceramic Plaque	CE1417		
11	Burner Fuel Bed Clamp	GZ10522		
12	Burner Assembly	GZ12137		1
13	Complete Burner Assembly	GZ13009		
14	Venturi Gasket	CE0209		1
15	Venturi	GZ10578		1
16	Access Hatch Assembly	GZ9914		1
17	Full Control Assembly	GZ11916		1
18	Steel Edge Clip	FA0523		1
19	Glass Clip Assembly	GZ6361		1
20	Tool Clip	FA0522		1
21	Mains Adapter	999-620		1
22	Embaglow	GZ8471		
23	Instructions/Fixing Kit	GZ11923		1

No.	Component	Part Code		Quantity
		Natural Gas	LPG	
24	Door Tool	GZ6690		1
25	Installation Frame	GZ11647		1
26	Door Assembly	GZ11650		1
27	Log Set	CE1423		
28	Glass Assembly	GZ7353		1
29	Base Side Piece - Black Reed & Brick Effect	CE1198		2
29	Base Side Piece - Vermiculite	CE1076		2
30	Side Lining LH & RH - Black Reed	CE1205		2
30	Side Lining LH & RH - Brick Effect	CE1197		2
30	Side Lining LH & RH - Vermiculite	CE1075		2
31	Lining Restraint Bracket	GZ10786		2
32	Rear Lining - Black Reed	CE1464		1
32	Rear Lining - Brick Effect	CE1466		1
32	Rear Lining - Vermiculite	CE1465		1
33	Rear Lining Support Bracket	GZ11645		1
34	Top Baffle	GZ11661		1
35	Pilot	PI0069		1
36	Thermocouple	PI0074		1
37	Electrode	PI0075		1
38	Injector - Size 184	IN0061		1
39	Rear Exit BF Termination Kit	8526		1

Servicing Instructions - Replacing Parts

18. Spares List - Control Assembly (All Models)

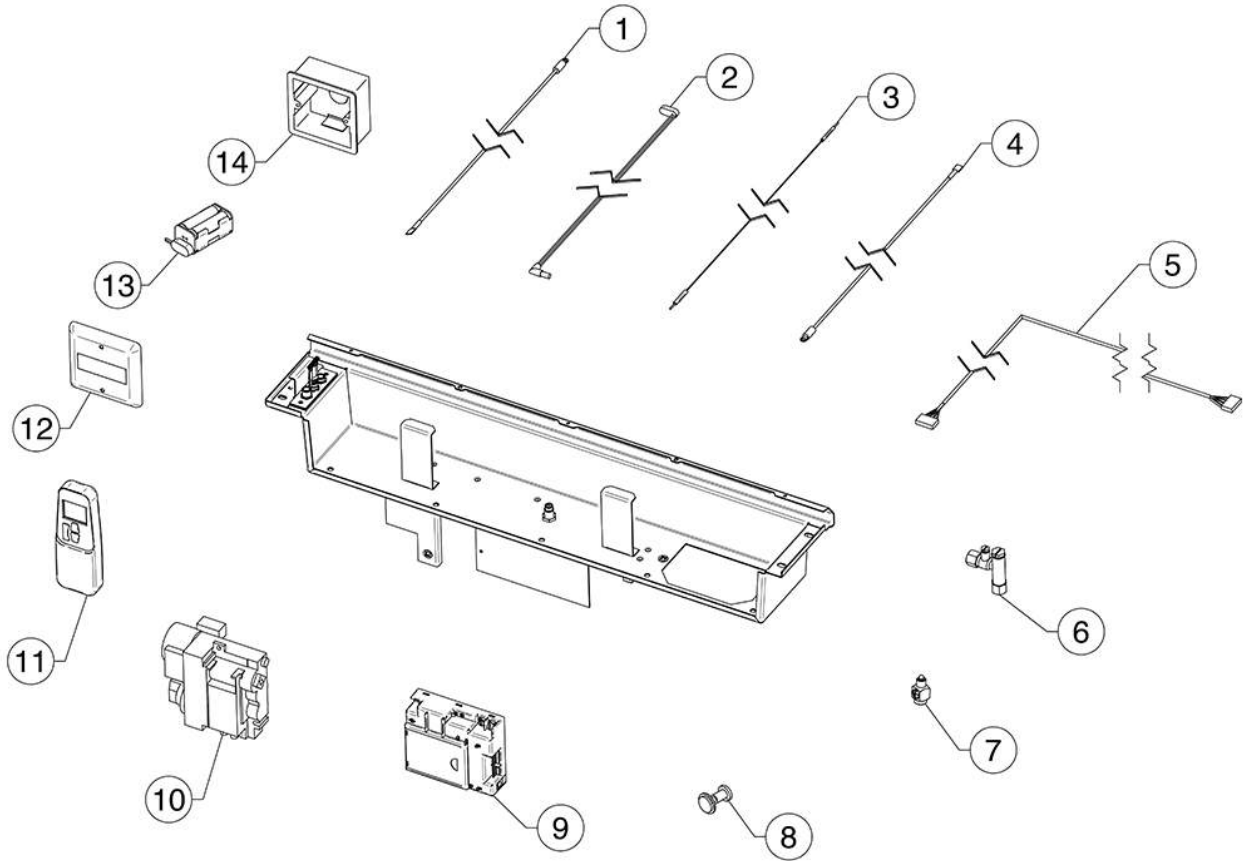

No.	Component	Part Code		Quantity
		Studio 1	Studio 2	
1	Thermocurrent Cable	EL0590		-
2	3m Battery Cable	GC0138		1
3	Ignition Cable	GC0125		1
4	Thermocurrent Cable	GC0136		-
5	350mm Connection Cable	GC0133		1
6	Pressure Test Restrictor Elbow	GC0095		1
7	Interrupter Block	EL0124		1
8	Magnetic Unit	GC0166		1
9	Bulkhead Fitting	N/A	FA0270	1
10	Receiver	GC0589		1
11	Control Valve	GC0123K		1
12	Thermostatic Handset	EL0571		1
13	Battery Access Cover	EL0591		1
14	Battery Holder	EL0410		1
15	Wall Box	EL0409		1

Service Records

1ST SERVICE

Date of Service:.....
Next Service Due:.....
Signed:.....
Retailer's Stamp/Gas Safe Registration Number

3RD SERVICE

Date of Service:.....
Next Service Due:.....
Signed:.....
Retailer's Stamp/Gas Safe Registration Number

5TH SERVICE

Date of Service:.....
Next Service Due:.....
Signed:.....
Retailer's Stamp/Gas Safe Registration Number

7TH SERVICE

Date of Service:.....
Next Service Due:.....
Signed:.....
Retailer's Stamp/Gas Safe Registration Number

9TH SERVICE

Date of Service:.....
Next Service Due:.....
Signed:.....
Retailer's Stamp/Gas Safe Registration Number

2ND SERVICE

Date of Service:.....
Next Service Due:.....
Signed:.....
Retailer's Stamp/Gas Safe Registration Number

4TH SERVICE

Date of Service:.....
Next Service Due:.....
Signed:.....
Retailer's Stamp/Gas Safe Registration Number

6TH SERVICE

Date of Service:.....
Next Service Due:.....
Signed:.....
Retailer's Stamp/Gas Safe Registration Number

8TH SERVICE

Date of Service:.....
Next Service Due:.....
Signed:.....
Retailer's Stamp/Gas Safe Registration Number

10TH SERVICE

Date of Service:.....
Next Service Due:.....
Signed:.....
Retailer's Stamp/Gas Safe Registration Number

Gazco Limited, Osprey Road, Sowton Industrial Estate, Exeter, Devon, England EX2 7JG
Technical Customer Services: (01392) 261950 Fax: (01392) 261951
E-mail: technicalservices@gazco.com

A member of the Stovax Group

E & O E