



Arundel

Multi-Fuel Stove, Model No. FCMSB Installation and Operating Instructions

**Read these Instructions and
use only the recommended fuels**

**Leave this manual with the householder
following installation**

To find a qualified installer, fuel supplier or chimney sweep please contact :-

UK - The Solid Fuel Association
7 Swanwick Court
Alfreton
Derbyshire
DE55 7AS
Tel : (0845) 601 4406
www.solidfuel.co.uk

R.O.I. - Irish Nationwide Fireplace Organisation
162 Capel Street
Dublin
Tel (01) 801 5959
www.fireplace.ie

This Flavel Arundel Stove may be used in smoke control areas when operated strictly in accordance with these instructions and with Soliftec Smoke Advice Sheet No. 1 (www.soliftec.com/smokeadvice.htm) when burning :
UK : Untreated wood logs or authorised smokeless fuels (exempted from s20 of the clean air act 1993)
ROI : Wood logs, smokeless fuels or peat briquettes, but not petroleum coke (Control of Atmospheric Pollution Regulations, 1970)

Contents	Description	Page Number
Section 1	Stove Information	3
Section 2	Stove Installation Requirements & Smoke Control Appliance Exemption.	4-6
Section 3	Stove Flue Connection to Chimney	7-8
Section 4	Suitable Wood Fuel	9
Section 5	Suitable Mineral Fuel	9
Section 6.1	Operation of the Flavel Arundel Stove	10
Section 6.2	Lighting the Stove - Installer Instruction	11
Section 6.3	Break in Fires - User Instruction	11
Section 6.4	Lighting the Stove - User Instruction	11
Section 6.5	Re-fuelling the Fire - User Instruction	12
Section 6.6	Maintenance	12
Section 7	Troubleshooting	13
Section 8	Removal & Re-Fitting the Stove Throat Plate	14
Section 9	Removal & Re-Fitting the Stove Smoke Stop	15
Section 10	Spare Parts	16

Section 1 - Stove Information

- 1.1 This Flavel Arundel multi-fuel stove meets the safety and performance requirements of European Standard EN 13420 for intermittent burning solid fuel roomheaters for installation in a dedicated chimney when operated in accordance with these instructions. Independently tested by BSRIA laboratory, Berkshire, UK.
- 1.2 Stove Dimensions - see figure 1 below.

Fig. 1

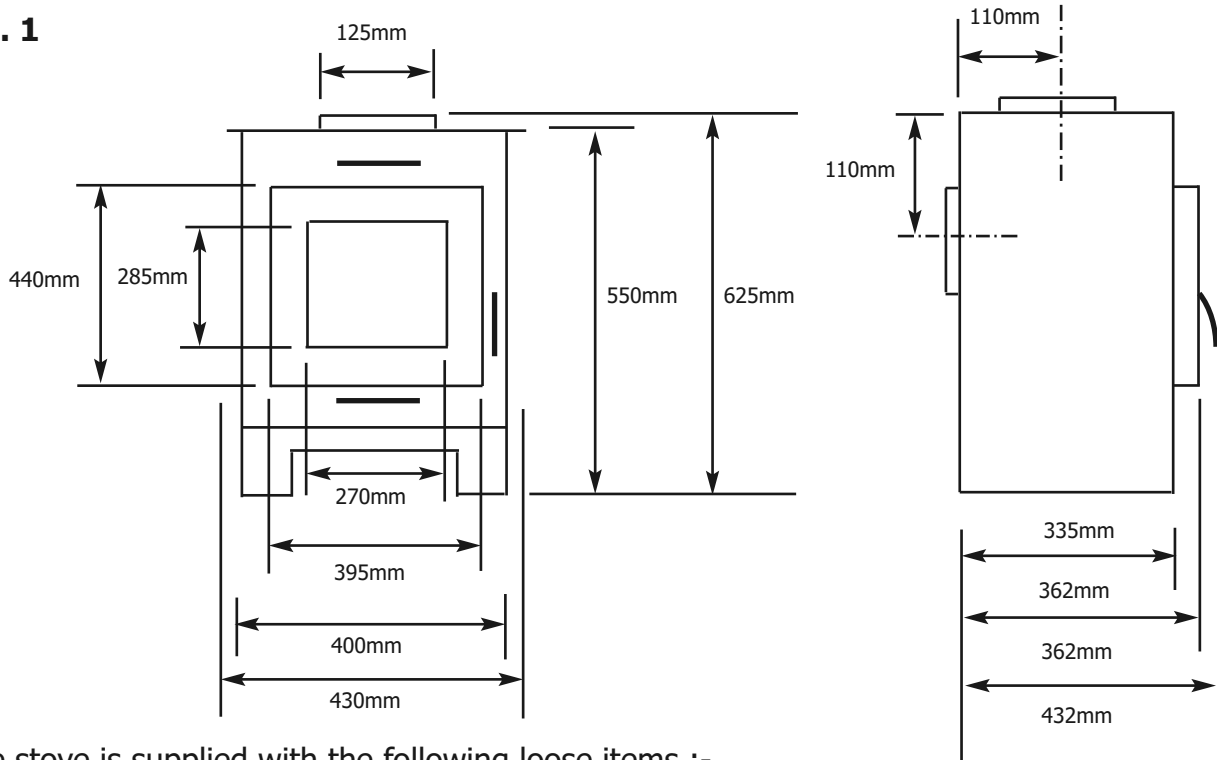

The stove is supplied with the following loose items :-

- 1 off ashpan, 1 off ashpan handle / riddling mechanism tool & 1 off stove glove.

Section 2 - Stove Performance Data

Fuel	Wood (Beech)	Mineral Fuel (Ancit)
Test standard	EN 13240 : 2001 + A2 2004	EN 13240 : 2001 + A2 2004
Re-fuelling Interval	1.0hrs	2.0hrs
Settings	10% primary, 50% secondary	50% primary, 0% secondary
Flue draught (Pa) (ins WG)	12 (0.05)	12 (0.05)
Efficiency	76.3%	78.4%
Recommended output (kW)	4.9	4.8
Mean flue gas temperature (°C)	212	218
Minimum air entry requirement	2700mm ²	2700mm ²
Minimum clearance to combustible surfaces	350mm Rear 375mm Side	350mm Rear 375mm Side
Emissions if O₂ = 13%		
NO _x mg/m ³	88	165
CO %	0.24	0.27
C _x H _y mg/m ³	690	736
Gas flow g/sec	6.6	5.1
Smoke emission rate g/hr	3.10 (High) 2.53 (Low)	N/A

Section 2 - Stove Installation Requirements

- 2.1 **WARNING** - Installing a stove is a controlled service, the law requires that the installation is completed by a qualified installer or that the building inspector is informed. Check with your local authority.
- 2.2 **ASBESTOS** - This Flavel stove does not contain asbestos, but asbestos material may be encountered during installation of the stove. If in doubt contact a suitably qualified professional to deal with Asbestos or material suspected to be asbestos.
- 2.3 **WEIGHT** - Your stove is heavy 64kg Net (70kg packed) - take care when moving it and ensure that the fireplace to which you are attempting to install it can take the weight - consider the use of a load distribution plate.
- 2.4 **FIREGUARD** - This stove becomes extremely hot in use, therefore a fireguard should be used if children, the elderly or infirm are present.
- 2.5 **FIREPLACE** - Stoves become extremely hot within use, therefore the fireplace to which the stove is installed must be made from durable fireproof materials. Thin stone slabs (less than 50mm) risk cracking unless cut into sections to allow for expansion and backed by heat resistant concrete. Even beyond the safety clearances stated items subjected to radiant heat from the stove can still become extremely hot, therefore please take care when siting items such as fuel, paper etc.
- 2.6 **AIR SUPPLY** - Your stove needs air to breathe and therefore perform correctly. There must be a permanent fresh air supply into the space to which it is installed equal to 550mm² for each kW of output. This can often be provided by air leaking around door frames etc. It is commonly accepted that this level of adventitious ventilation alone may suffice for stoves of output less than 5kW but in the case of any doubt, fit a purpose made air vent. If an extractor fan is fitted in the room, any interconnecting room or room in the vicinity can detrimentally affect the performance of the stove so please check stove performance with these extraction fans in operation. Where there are additional combustion appliances within the property please ensure that the relevant requirements of Approved Document J of the Building Regulations are complied with.
When air inlet grills are positioned to provide combustion air they must not be liable to blockage. Regular checks should be made to ensure that any air inlet grill is not obstructed.
- 2.7 **REGULATIONS** : All local regulations including those referring to National and European standards need to be complied with when installing this appliance.

- 2.8 **CHIMNEY** - The chimney must conform to the following requirements :-
- 2.8.1 Generate a draught when in use of minimum 12 Pa (0.05 ins WG).
 - 2.8.2 Have a minimum internal cross section equivalent to not less than 125mm diameter. (12,272mm²)
 - 2.8.3 Be capable of withstanding the flue gas temperatures generated by the stove.
 - 2.8.4 Terminating at least 1 metre above the ridge.
 - 2.8.5 Be free from any cracks or sources of leakage and be sealed throughout its entire length to prevent leakage of products of combustion into the property.
 - 2.8.6 Have no bends greater than 45 degrees.
 - 2.8.7 Have no obstructions and having been swept throughout its entire length.
 - 2.8.8 Being connected only to this Flavel stove.
 - 2.8.9 Conforming to local building regulations and rules in force.
 - 2.8.10 Being adequately insulated.
 - 2.8.11 Where the flue passes through timber or thatch or vulnerable materials specialist advice must be sought.

2.9 **APPLIANCE EXEMPTION UNDER SECTION 21 OF THE CLEAN AIR ACT 1993 AND SMOKE CONTROL AREAS**

- 2.9.1 The Flavel Arundel multi-fuel free-standing stove, model number FCMSB has been exempted under the Clean Air Act 1993 for use in smoke control areas when burning wood logs when it is fitted with the smoke control stop (part number F-176950)

The Clean Air Act 1993 and Smoke Control Area's

- 2.9.2 Under the Clean Air Act local authorities may declare the whole or part of the district of the authority to be a smoke control area. It is an offence to emit smoke from a chimney of a building, from a furnace or from any fixed boiler if located in a designated smoke control area. It is also an offence to acquire an "unauthorised fuel" for use within a smoke control area unless it is used in an "exempt" appliance ("exempted" from the controls which generally apply in a smoke control area).
- 2.9.3 The Secretary of State for Environment, Food and Rural Affairs has powers under the Act to authorise smokeless fuels or exempt appliances for use in smoke control areas in England. In Scotland and Wales this power rests with Ministers in the devolved administrations for those countries. Separate legislation, the Clean Air (Northern Ireland) Order 1981, applies in Northern Ireland. Therefore it is a requirement that fuels burnt or obtained for use in smoke control areas have been "authorised" in Regulations and that appliances used to burn solid fuel in those areas (other than "authorised" fuels) have been exempted by an Order made and signed by the Secretary of State or Minister in the devolved administrations.

Further information on the requirements of the Clean Air Act can be found here :
<http://smokecontrol.defra.gov.uk>

Your local authority is responsible for implementing the Clean Air Act 1993 including designation and supervision of smoke control areas and you can contact them for details of Clean Air Act requirements

2.9 **APPLIANCE EXEMPTION UNDER SECTION 21 OF THE CLEAN AIR ACT 1993 AND SMOKE CONTROL AREAS (CONTINUED).**

2.9.4 **Refuelling on to a low fire bed**

If there is insufficient burning material in the fire bed to light a new fuel charge, excessive smoke emission can occur. Refuelling must be carried out onto a sufficient quantity of glowing embers and ash that the new fuel charge will ignite. If the fire bed is too low or cool, suitable kindling must be used to re-light fires.

2.9.5 **Fuel overloading**

The maximum amount of fuel specified in this manual must not be exceeded, overloading can cause excessive smoke.

2.9.6 **Operation with door left open**

Operation with the door left open can cause excessive smoke. The appliance must not be operated with the door left open except as directed in the instructions.

2.9.7 **Dampers left open**

Operation with the air controls or dampers can cause excessive smoke. The appliance must not be operated with the air controls or dampers left open except as directed in the instructions.

Section 3 - Stove Flue Connection to the Chimney

3.1 The flue can be connected to the stove via either the top or the rear outlet. The stove can then be sealed to the chimney using a short length of uninsulated flue pipe as shown below and overpage in figures 2, 3 & 4.

3.1.1 Top flue outlet into existing chimney - figure 2

Fig. 2

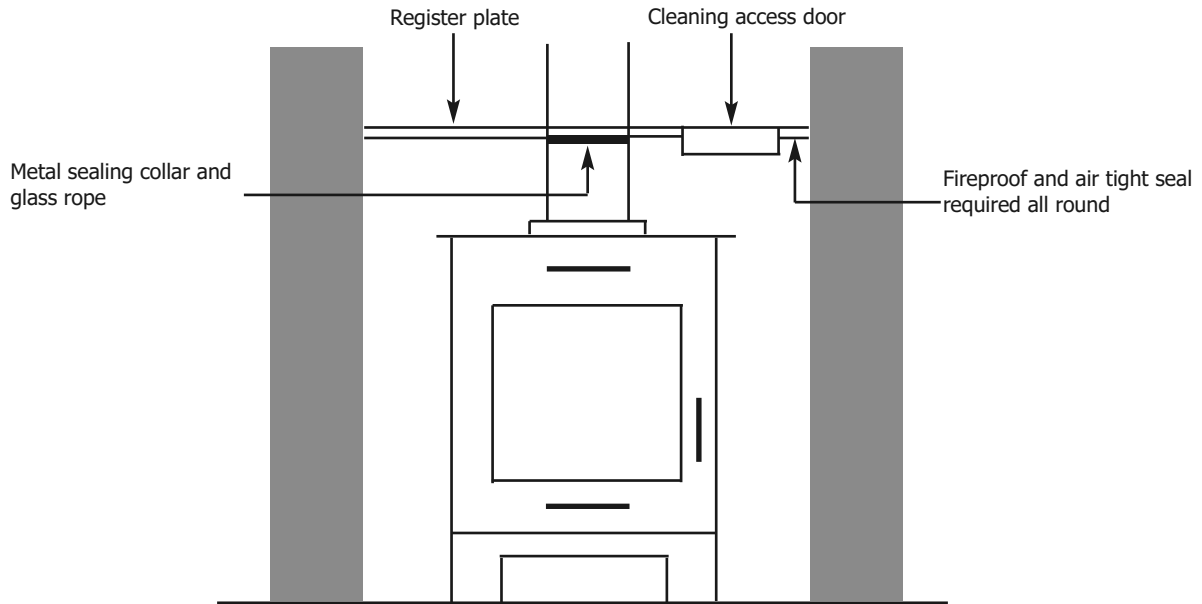

3.1.2 Top flue outlet sleeved through wall into external insulated flue - figure 3

Fig. 3

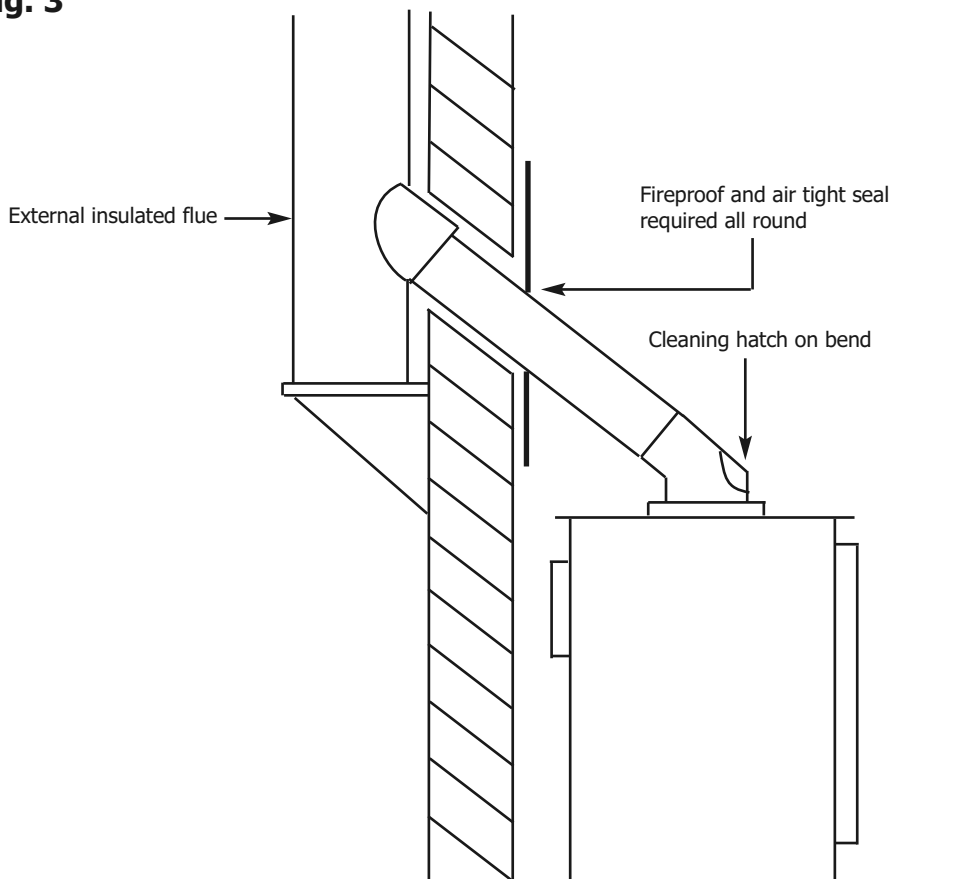

3.1.3 Rear flue outlet into chimney with sealing collar - figure 4

Fig. 4

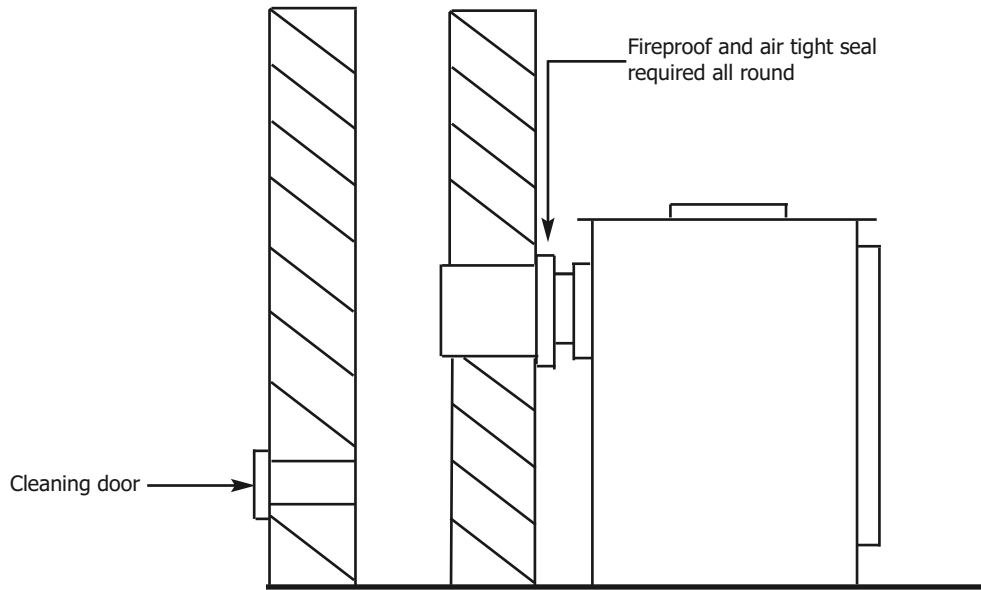

3.1.4 Rear outlet by "tee" piece with cleaning door - figure 5

Fig. 5

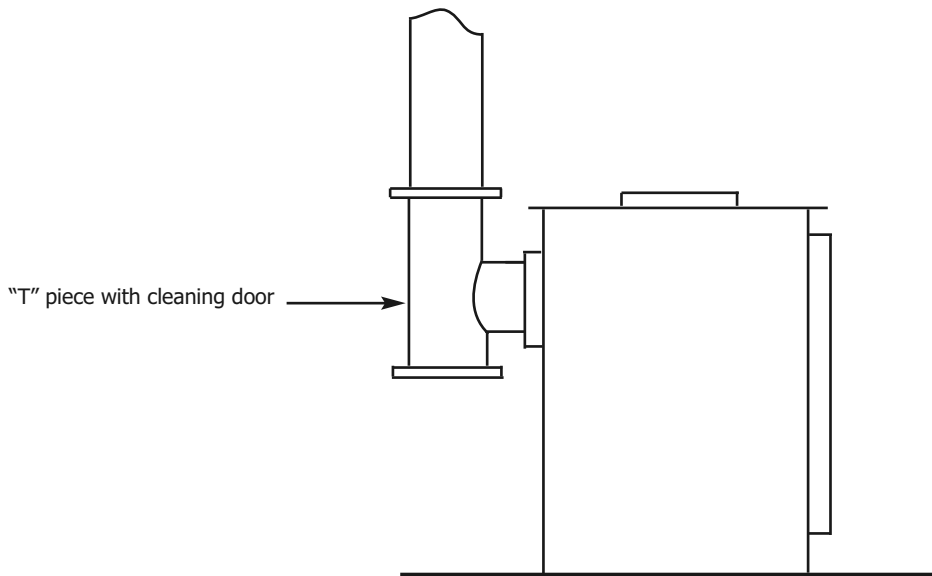

3.1.5 **IMPORTANT INFORMATION** - whichever method is used it is imperative that the route from the stove to the chimney terminal is completely air-tight, even very small air gaps can adversely affect the flue draught. Seal all joints with fireproof cement and / or heatproof rope. The entire construction should be made of durable fireproof materials.

Section 4 - Suitable Wood fuel for the Flavel Arundel Stove - User instruction

- 4.1 SMOKE CONTROL - In certain areas special rules apply regarding the use of some fuels, please ensure that you check with your local authority. This Flavel Arundel stove may be used in smoke control area's when operated strictly in accordance with these instructions and with Soliftec Smoke Advice sheet No. 1, see front cover of this manual for further details.
- 4.2 WOOD TYPES - All types of wood are suitable providing they are well seasoned, untreated and have a moisture level of between 12% & 20%. For softwoods they will need to have been left in storage for 9 months in order for the moisture to be evaporated. For hardwoods this could take in excess of 18 months for the wood to season. If you are unsure of the moisture content of your logs it is recommended that you purchase a suitable moisture meter which will allow you to measure the moisture content of the wood you are planning to use.
- 4.3 WOOD SIZE - It is recommended that logs should be no greater than 5" / 125mm in diameter and a maximum of 250mm in length. The logs must be dry with a moisture content no greater than 20%.
- 4.4 WET TIMBER WARNING - Wet timber and logs must not be used as this will create excess tar deposits in the chimney and the stove and could considerably increase the possibility of a chimney fire. Wet timber and wood also increases emissions, creates more smoke and will reduce the lifespan of the stove.
- 4.5 JOINERY WASTE - Burning joinery waste is acceptable, providing the wood is untreated and dry. Joinery waste generally is softwood and hence will not burn as cleanly or for as long as hardwood logs.

Section 5 - Suitable Mineral fuel for the Flavel Arundel Stove - User instruction

- 5.1 ANTHRACITE - (Smokeless) is a natural hard, shiny form of coal. Slow to light it can burn for very long periods with great heat. Use the "small" size of this fuel.
- 5.2 BRIQUETTES - Compressed blocks of fuel, generally able to burn for long periods. Trade names for these fuels include "Homefire" and "Phurnacite".
- 5.3 PETROLEUM COKE - THIS FUEL IS NOT SUITABLE FOR USE WITH THIS STOVE. If used, "Petcoke" (also known as "Longbeach") will rapidly degrade the interior of the stove.
- 5.4 HOUSECOAL OR BITUMOUS COAL - THIS FUEL IS NOT SUITABLE FOR USE WITH THIS STOVE. This fuel is designed for use in open fires, it makes tarry smoke flammable gas which makes it difficult to control in a closed fire such as a stove.

IMPORTANT NOTE : DO NOT BURN ANY FORM OF HOUSEHOLD WASTE WITH THIS STOVE AND NEVER USE ANY FORM OF LIQUID FUEL ON THE STOVE.

Section 6 - Operation of the Flavel Arundel Stove - User Instruction

- 6.1 There are 3 main controls on your stove as shown below in figure 6, namely the primary air control, the secondary air control and the riddling mechanism. The stove is also supplied with a glove and an ashpan handle to be used as described in this section.

Fig. 6

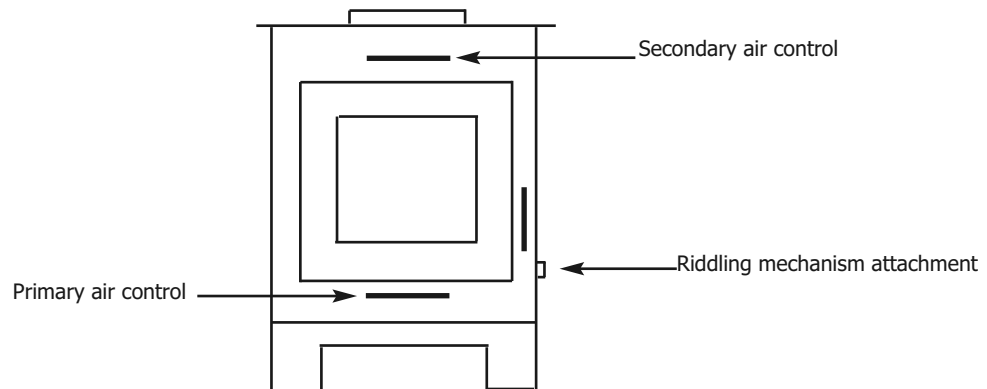

- 6.1.1 **Primary air control** - This is located at the bottom of the stove door. The primary air control allows air into the stove and under the grate area. Keeping this vent open on start up and when refuelling will allow the fire to get up to temperature quickly.
- 6.1.2 **Secondary air control** - This is located above the stove door in the centre. The secondary air control provides an air wash facility to keep the stove glass clean.
- 6.1.3 **Riddle mechanism** - This is located on the right hand side of the stove at low level. A tool is supplied to operate the riddle mechanism. Align the square cut out in the tool with the riddling mechanism and move backwards and forwards to operate. When there is a build up of ash on the grate of the stove, actuate the riddle mechanism to remove the ash from the grate into the ashpan. Use the riddle mechanism each time fuel is loaded into the stove.
- 6.14 **Hand glove** - a glove is provided with the stove to adjust the air controls, actuate the riddle mechanism and open / close the door when the stove is hot. Please note all parts of the stove will become hot in use and care needs to be taken to avoid injury through burning.
- 6.1.5 **Ashpan handle** - a ashpan handle is supplied for use with the stove, please use this in conjunction with the glove and be aware that ash and embers in the ashpan will be extremely hot. Take care when discarding hot embers.
- 6.1.6 **Smoke Stop** - To make sure your stove always receives enough air to burn away the smoke produced when burning wood, a smoke stop is fitted to prevent the secondary air control from being fully closed. The smoke stop must always be in place when burning wood in smoke control areas of the United Kingdom.

Section 6.2 - Lighting the stove - Installer instruction

- 6.2 Prior to first lighting the stove ensure that the following is complete :-
 - 6.2.1 Installation of the stove and relevant building work is completed.
 - 6.2.2 The chimney is suitable, sound and free from obstruction.
 - 6.2.3 Adequate ventilation and provision for combustion air has been made.
 - 6.2.4 The installation is compliant with building regulations and local authority regulations as applicable.
 - 6.2.5 The chimney pull is a minimum of 12 Pa
 - 6.2.6 The fuels that are planning to be burnt comply with those listed as suitable in section 5 of this manual.

Section 6.3 - Break-in fires - User instruction

- 6.3 When the stove is new, for the first 20 hours burning only use gentle small controlled wood fires (NO COAL) during which the first three fires must be small kindling wood fires only. This is required to correctly adhere the paintwork on the stove. After the first three fires gently increase the size of the fuel and duration of the burn time. **Failure to adhere to this instruction will result in likely damage to the paintwork on the stove. In addition, during the "break in fires" do not touch the paintwork on the stove as during this period the paintwork will be relatively soft and will mark easily.**

Section 6.4 - Lighting the stove - User instruction

- 6.4 When first lighting the stove comply with the following :-
 - 6.4.1 Ensure that the ashpan is in place
 - 6.4.2 Ensure that both primary and secondary air controls are in the fully open position (to the left hand side when viewed from the front).
 - 6.4.3 Construct a pile of kindling in the centre of the grate using approximately 1kg of kindling wood.
 - 6.4.4 Use a single chemical firelighter in the base of the kindling and light with an appropriate ignition source. Leave the door partially open but do not leave the area of the stove.
 - 6.4.5 As soon as the fire is established in the kindling, shut the door of the stove.
 - 6.4.6 After 5 minutes or as soon as the kindling is well lit, add a further 3 small pieces of wood of approximate weight 1kg.
 - 6.4.7 Once these logs are lit, after a further 5 minutes add a further 3 logs weighing approximately 1.5kg.
 - 6.4.8 Once these logs are lit, reduce the settings on the primary and secondary air controls to a suitable level to suit your requirements.
 - 6.4.9 Re-fuel as per section 6.5 as and when required.
 - 6.4.10 **DO NOT OPERATE THE STOVE WITH THE DOOR PERMANENTLY OPEN.**
 - 6.4.11 This stove is not suitable for connection to a central heating system.
 - 6.4.12 **THIS STOVE MUST NOT BE USED AS AN INCINERATOR AND ONLY USE RECOMMENDED FUELS.**
 - 6.4.13 **IF BURNING WOOD IN SMOKE CONTROL AREAS PLEASE READ AND COMPLY WITH THE REQUIREMENTS OF SECTION 2.9**

Section 6.5 - Re-fuelling the fire - User instruction

- 6.4 When refuelling the stove, follow the procedure as detailed below :-
 - 6.4.1 Open the primary air vent to the fully open position.
 - 6.4.2 Add up to 1.5kg of wood or mineral fuel.
 - 6.4.3 After approximately 2 minutes or when the flames from the fresh fuel are fully established, close the primary air vent.
 - 6.4.4 At high power output your stove will require re-fuelling approximately every hour.
 - 6.4.5 Do not leave the stove until the newly added fuel is well established.
 - 6.4.6 Always refuel onto hot embers and riddle at each refuel.
 - 6.4.7 If the fire has died out at the point of refuelling use kindling to re-establish the fire.
 - 6.4.8 **DO NOT OVERLOAD THE STOVE WITH FUEL.**
 - 6.4.9 Reduced burn rates can be achieved via use of the primary and secondary air controls.
 - 6.4.10 This stove is suitable for intermittent burning and should not be used constantly for extended periods. Not suitable for overnight burning.
 - 6.4.11 During certain atmospheric conditions it may be difficult to achieve the required flue draught. If such conditions occur it may require a specialist cowl on the chimney to achieve the correct flue draught to ensure correct operation of the stove. In such circumstances do not use the stove and obtain expert advice.
 - 6.4.12 In the event of a chimney fire, close the primary and secondary air controls to the stove, evacuate the building and call the fire brigade.

Section 6.6 - Maintenance - If in doubt contact a competent person

- 6.6 Regular cleaning and maintenance of the stove is essential for safety and efficiency. Flavel recommend a suitably qualified (HETAS) registered engineer is used for servicing purposes. Ensure the following steps are completed regularly :-
 - 6.6.1 The ashpan should be emptied after every use and during use when refuelling as required.
 - 6.6.2 When the stove is cold, clean out any build of ash or unburnt fuel from the grate, around the ashpan and in any nooks or crannies of the stove. Complete monthly as a minimum, including on top of the stove throat plate, see section 8.
 - 6.6.3 The flue, flue pipe and chimney will require regular sweeping to minimise the build up of soot and tar, annually as a minimum. The stove should of been installed with suitable access doors in the flueway to achieve this. However in the event that suitable access doors have not been installed access to the flue can be achieved by removal of the throat plate in the stove itself, see section 8.
 - 6.6.4 If the stove door glass is stained, it may be that the secondary air control may need to be opened up during use, this is dependent upon many factors such as flue pull etc. In the event of excessive staining use a ceramic glass cleaner to remove the marks when the stove is completely cool.
 - 6.6.5 Note that the internal boards of the stove will craze with normal use, this is not a fault of the boards. Cracks will not adversely affect the stove's performance providing the boards remain in position. If pieces break from the boards then replace the boards as necessary. You can significantly increase the life of the boards by burning the correct fuels in the stove as detailed in section 4 for wood fuels and section 5 for mineral fuels.

Section 7 - Troubleshooting

7.1 In the unlikely event of experiencing problems with your stove, please consult the following :-

7.1.1 **Smoke from the chimney** - a little smoke will be emitted from the chimney when the fire is cold. Ensure the correct, dry wood or smokeless fuels to prevent smoke emissions.

7.1.2 **Poor heat output** - this Flavel Arundel stove will generally heat a room of 12m³ room volume per kW of heat output, so if operating at 5kW output it could heat a room of 12m³ x 5 = 60m³ or 5 metres square. The actual size depends upon factors such as insulation and air change within the room. To attempt to use too smaller stove to heat too larger room will result in overheating the stove and potentially damaging it.

7.1.3 **Lack of controllability** - some fuels may burn excessively until the gases in them have been used up, you can reduce this effect by using the air controls on the stove.

7.1.4 **Difficulty burning for extended periods** - If the fire goes out with plenty of fuel in the stove, try leaving the air controls open a little more. Check the door seal is sound and that there are no gaps or cracks in the flue or flue joints. For longer burn periods use mineral fuels such as "anthracite".

7.1.5 **Overfiring** - If the stove is left with the air controls in the open position for too long this will result in overfiring, excessive chimney temperatures and risk of component failure and chimney fires. Use a stove thermometer, available from your Flavel stockist can help to obtain a satisfactory burn temperature.

7.1.6 **Smoke coming into the room** - Product of combustion (fumes) are poisonous and hence smoke emission must never be tolerated. If smoke comes back into the room when the stove is lit the cause must be fully investigated to ascertain the problem and rectified before using the stove. Check for build up of ash on the throat plate, the condition of the door seals, the condition of the seal between flue and chimney and any air ventilation into the room is not blocked. If the symptoms persist, consult a suitably qualified person, such as a HETAS registered engineer to further investigate and resolve the problem.

Section 8 - Removal & re-fitting the stove throat plate

If in doubt contact a competent person

- 8.1 Ensure that the stove is cool.
- 8.2 Open the stove door.
- 8.3 As shown in figure 7 below remove the throat plate from the stove, clean off any fly ash etc. If using throat plate removal as a form of access to the chimney please ensure any debris that comes from the chimney is fully removed from the stove before attempting to refit the throat plate.
- 8.4 Replace in reverse order.
- 8.5 Check the stove for correct performance and flue products clearance.

Fig. 7

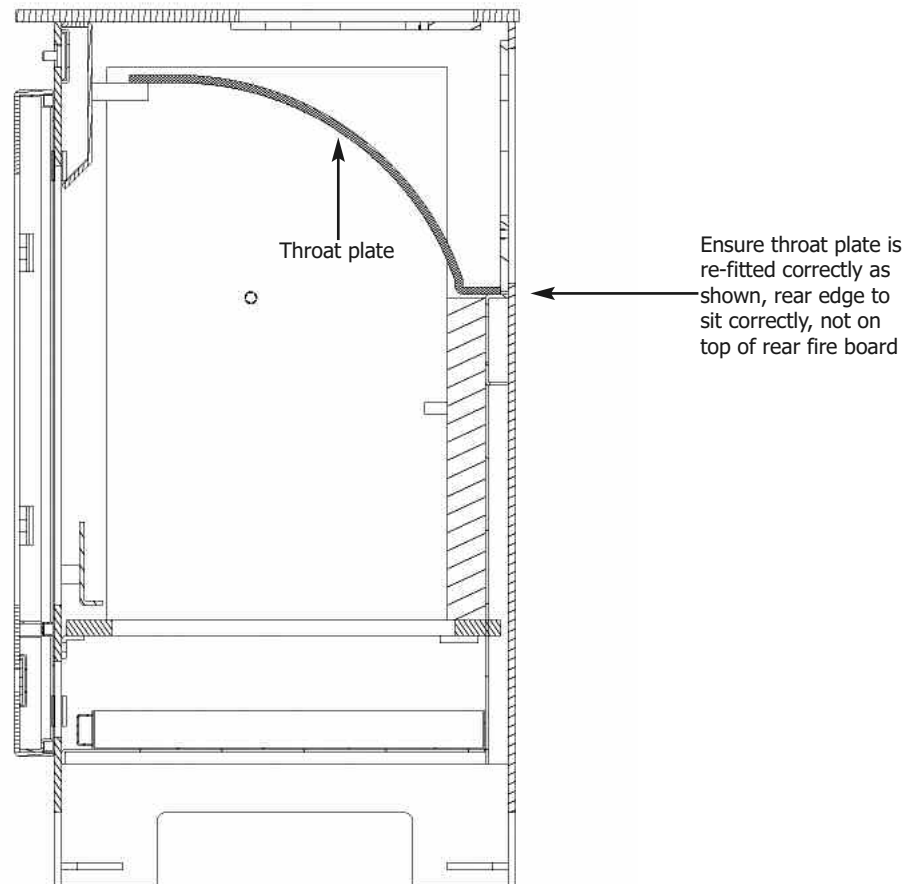

Section 9 - Removal & re-fitting the smoke stop

If in doubt contact a competent person

- 9.1 **WARNING :** The smoke stop is fitted to ensure that your stove receives enough air to burn away the smoke when burning wood. The smoke stop is fitted to prevent the secondary air control being fully closed. If, and only if smoke is not a concern you may unscrew and remove the smoke stop that was fitted during the manufacture of your Flavel Arundel stove. Controllability and burn times may be improved, but more smoke may also be emitted. The smoke stops must always remain in place when burning wood in smoke control area's of the United Kingdom. Failure to do so invalidates the DEFRA approval of the stove.
- 9.2 To remove the smoke stop, firstly ensure that the stove is cool.
- 9.3 Locate the smoke stop on the secondary air control as shown below in figure 8.

Fig. 8

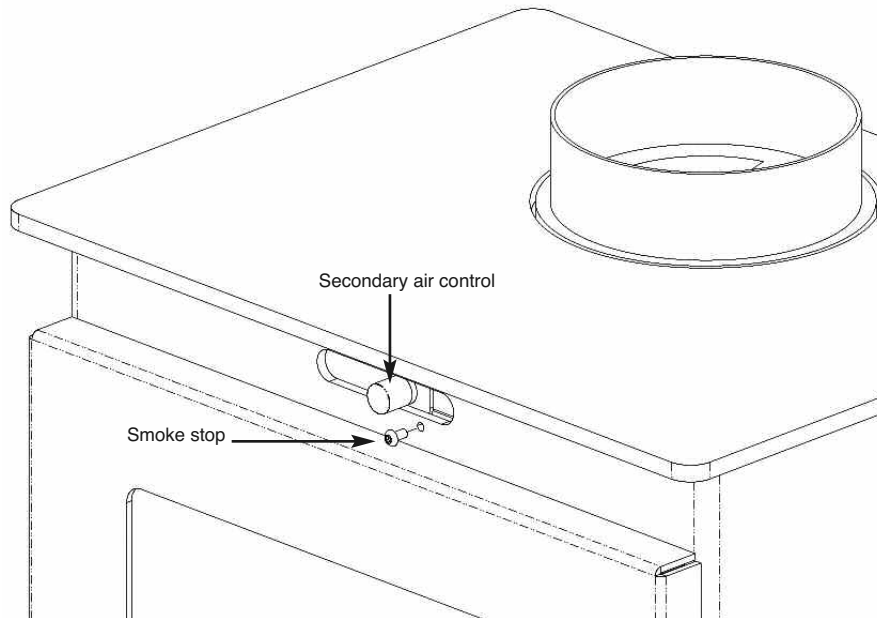

- 9.4 Remove the smoke stop by unscrewing in a anti-clockwise direction.
- 9.5 Keep the smoke stop in a safe place for future use.
- 9.6 Re-fit in reverse order if necessary.

Section 10 - Spare Parts

IMPORTANT : Only genuine Flavel spare parts should be used with this stove and no unauthorised modifications to this stove are permitted.

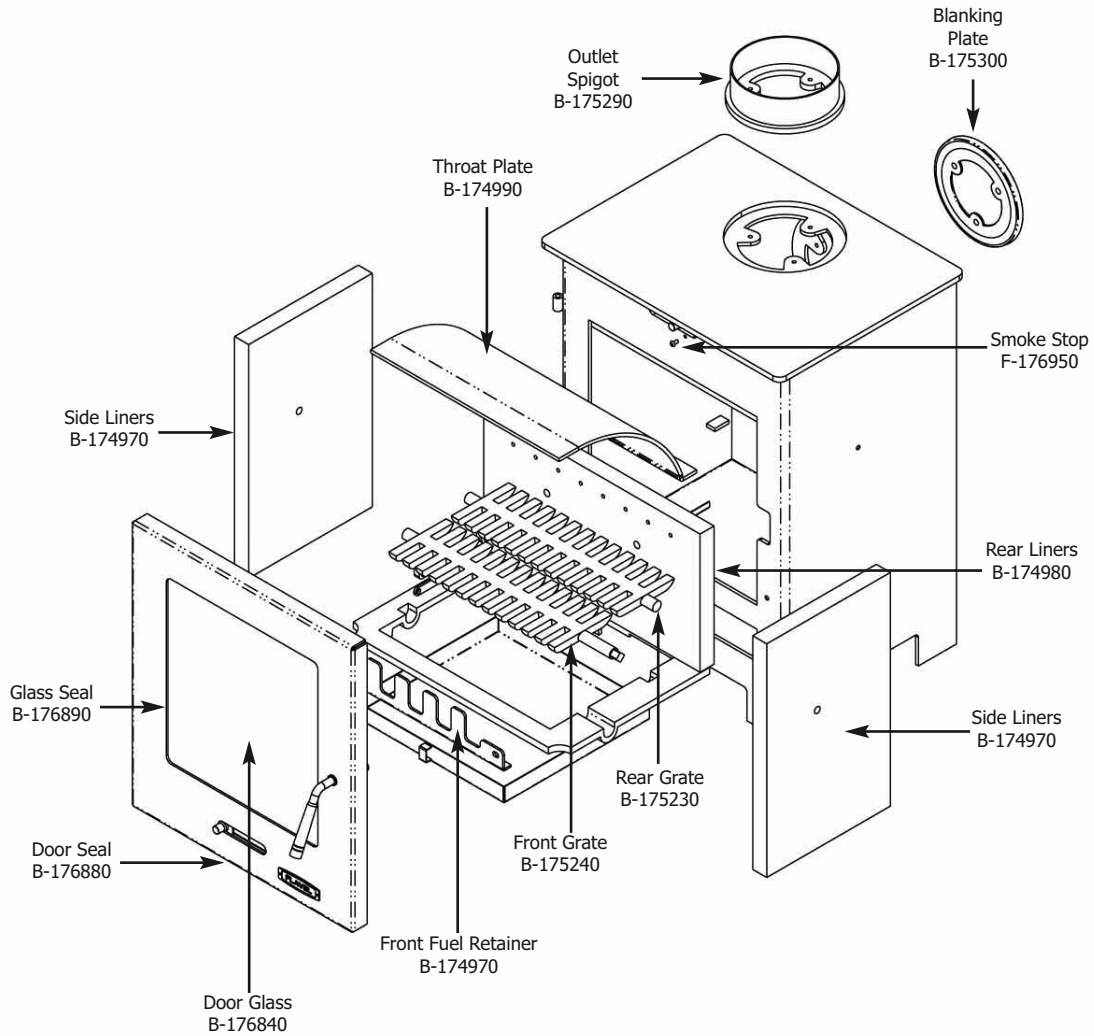

Due to our policy of continual improvement and development the exact accuracy of illustrations and descriptions contained in this book cannot be guaranteed.

B-176820

**Issue 1
19th November 2014**



BFM Europe Ltd.
Trentham Lakes
Stoke-on-Trent
Staffordshire
ST4 4TJ

www.bfm-europe.com

Telephone - General Enquiries :
Telephone - Service :

(01782) 339000
(0844) 7700169 or (01782) 339008