

Dovre 425

Conventional Flue Log Effect Stove

With Upgradeable Control Valve



Instructions for Use, Installation and Servicing

For use in GB, IE (Great Britain and Republic of Ireland)

IMPORTANT

THE OUTER CASING, FRONT AND GLASS PANEL BECOME EXTREMELY HOT DURING OPERATION AND WILL RESULT IN SERIOUS INJURY AND BURNS IF TOUCHED. IT IS THEREFORE RECOMMENDED THAT A FIREGUARD COMPLYING WITH BS 8423 (LATEST EDITION) IS USED IN THE PRESENCE OF YOUNG CHILDREN, THE ELDERLY OR INFIRM.

ENSURE THAT ALL COMBUSTIBLE MATERIALS ARE NOT POSITIONED ABOVE OR NEAR TO THE APPLIANCE OUTER CASING.

This product contains a heat resistant glass panel. This panel should be checked during Installation and at each servicing interval. If any damage is observed on the front face of the glass panel (scratches, scores, cracks or other surface defects), the glass panel must be replaced and the appliance must not be used until a replacement is installed. Under no circumstances should the appliance be used if any damage is observed, the glass panel is removed or broken.

It is essential that ALL of the screws that retain the glass frame are replaced and tightened correctly. Under no circumstances should the appliance be operated if any of these screws are loose or missing.

These Instructions must be left with the appliance for future reference and for consultation when servicing the appliance. Please make the customer aware of the correct operation of the appliance before leaving these instructions with them.

The commissioning sheet found on Page 3 of this Instruction manual must be completed by the Installer prior to leaving the premises.



Contents

Covering the following models:

Model	NATURAL GAS	LPG
Dovre 425	DV541-124	DV541-447

Appliance Commissioning Checklist	3
User Instructions.....	4
Installation Instructions.....	10
Technical Specifications	10
Site Requirements.....	12
Installation	14
Commissioning	19
Servicing Requirements	20
Fault Finding.....	20
How to replace parts	22
Spare parts list	28
Service Records	31
Information Requirement - Gas Heaters	32



It is a requirement of the Building Regulations 2010 that the installation of this appliance is notified to the Local Authority. It is the responsibility of the GasSafe registered installer to carry out this notification to the Local Authority via the GasSafe register Competent Persons Scheme in England and Wales (different rules apply in Scotland and Northern Ireland).

When the installation has been notified, GasSafe will send a Building Regulations Compliance Certificate to you containing details of the work completed. Please ensure that the person responsible for the installation of this appliance completes this notification and records it in the Appliance Commissioning Checklist on page 3.

IT IS YOUR RESPONSIBILITY TO COMPLY WITH THE BUILDING REGULATIONS AND BE ABLE TO PRODUCE THIS CERTIFICATE SHOULD IT BE REQUIRED IN THE FUTURE.



Appliance Commissioning Checklist

To assist us in any guarantee claim please complete the following information:-

IMPORTANT NOTICE

Explain the operation of the appliance to the end user, hand the completed instructions to them for safe keeping, as the information will be required when making any guaranteed claims.

FLUE CHECK	PASS	FAIL	
1. Flue Is correct for appliance			
2. Flue flow Test			
3. Spillage Test			
GAS CHECK			
1. Gas soundness & let by test			
2. Standing gas pressure	mb		
3. Appliance working pressure (on High Setting) NB All other gas appliances must be operating on full	mb		
4. Gas rate	m ³ /h		
5. Does Ventilation meet appliance requirements			
6. Have controls been upgraded (Upgradeable models only)	8455 Standard	YES	NO
	8456 Programmable Thermostatic and Timer	YES	NO
SAFETY CHECK			
1. Glass checked to ensure no damage, scratches, scores or cracks			
2. Door secured correctly and all screws replaced			
BUILDING CONTROL NOTIFICATION	YES	NO	
1. Installer notified GasSafe/Local Authority of installation via Competent Persons Scheme?			

RETAILER AND INSTALLER INFORMATION

Retailer	Installation Company
.....
.....
Contact No.	Engineer
.....
Date of Purchase	Contact No.
.....
Model No.	GasSafe Reg No.
.....
Serial No.	Date of Installation
.....
Gas Type	

User Instructions

Welcome

Congratulations on purchasing your Dovre 425 stove, if installed correctly Dovre hope it will give you many years of warmth and pleasure for which it was designed.

The purpose of this manual is to familiarise you with your appliance, and give guidelines for its installation, operation and maintenance. If, after reading, you need further information, please do not hesitate to contact your Dovre retailer.

WARNING



In the event of a gas escape or if you can smell gas, please take the following steps:

- **Immediately turn off the gas supply at the meter/emergency control valve**
- **Extinguish all sources of ignition**
- **Do not smoke**
- **Do not operate any electrical light or power switches (On or Off)**
- **Ventilate the building(s) by opening doors and windows**
- **Ensure access to the premises can be made**

Please report the incident immediately to the National Gas Emergency Service Call Centre on 0800 111 999 (England, Scotland and Wales) , 0800 002 001 (N. Ireland) or in the case of LPG, the gas supplier whose details can be found on the bulk storage vessel or cylinder.

The gas supply must not be used until remedial action has been taken to correct the defect and the installation has been recommissioned by a competent person.

1. General

- 1.1 Installation and servicing must only be carried out by a competent person whose name appears on the GasSafe register. To ensure the engineer is registered with GasSafe they should possess an ID Card carrying the following logo:



- 1.2 In all correspondence, please quote the appliance type and serial number, which can be found on the data badge accessed from the rear of the appliance or on the Commissioning Checklist Page 3.
- 1.3 **Do not** place curtains above the appliance: You must have 300mm clearance between the appliance and any curtains at either side.

- 1.4 The manufacturer considers the full outer casing of this stove to be a working surface and it will become hot whilst in operation. A suitable guard is recommended to protect young children, the aged and the infirm.
- 1.5 No furnishings or other objects should be placed within 1 metre of the front of the appliance.
- 1.6 If a shelf is fitted, a distance of 225mm above the appliance is required.
- 1.7 Do not attempt to burn rubbish in this stove.
- 1.8 This appliance must only be operated with the door secured firmly in position. If any cracks appear in the glass the appliance must not be used until the glass panel is replaced.
- 1.9 This product is guaranteed for 2 years from the date of installation, as set out in the terms and conditions of sale between Dovre and your local Dovre retailer. Please consult with your local Dovre retailer if you have any questions. In all correspondence always quote the Model Number and Serial Number.

2. Operating the Appliance

- 2.1 The control valve is at the foot on the right-hand side of the appliance. It has two controls, Diagram 1:
1. The right-hand knob controls the pilot ignition
 2. The left-hand knob controls the main burner

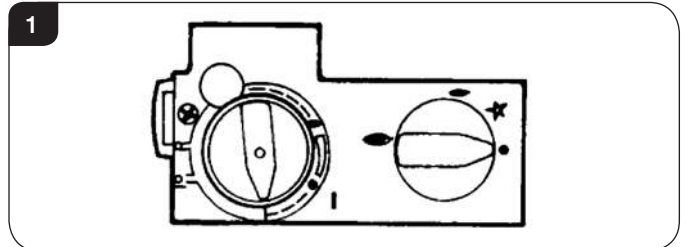

- 2.2 Refer to separate instructions if your appliance is upgraded to include battery remote control. The instructions below apply whether or not you have the remote upgrade.

Lighting the Pilot

- 2.3 To start the left-hand and right-hand control knobs must both point to off (●):
- 2.4 Press in the right-hand control knob and rotate anti-clockwise until a click is heard. Continue to press in. The knob points to the pilot (←).

The pilot is lit.

- 2.5 Keep the knob depressed for 10 seconds before releasing. The pilot remains lit.

Repeat the above steps if the pilot does not stay lit.

NOTE: If the pilot goes out, the Interlock system prevents you lighting again for a short period.

- 2.6 If, after repeating the above steps the pilot does not light, contact your Retailer or Installer.
- 2.7 Turn the right-hand knob to the left to main burner setting (◀).

User Instructions

Adjusting the Flame height

- 2.8 You can now adjust the flame height and temperature using the left-hand control knob.
- 2.9 Turn the left-hand knob anti-clockwise to increase the flame height.
- 2.10 Turn clockwise to decrease the height.

i **IMPORTANT: YELLOW FLAMES TYPICALLY APPEAR WHEN THE APPLIANCE HAS REACHED NORMAL OPERATING TEMPERATURE. THIS CAN TAKE UP TO 30 MINUTES.**

! **WARNING: IF THE APPLIANCE FAILS TO LIGHT OR BECOMES EXTINGUISHED IN USE, WAIT 3 MINUTES BEFORE ATTEMPTING TO RELIGHT.**

3. Turning OFF the Appliance

- 3.1 To turn the main burner off turn the left-hand knob until it points to off (●). Just the pilot remains lit.
- 3.2 Press in and turn the right-hand knob until it points to off (●). The pilot goes out.

4. Upgrading the Appliance

- 4.1 The appliance is fitted with a control valve that can easily be upgraded to battery powered remote control. There are two versions of this control which can be obtained through your local Dovre retailer. There is no requirement for this upgrade to be carried out by an approved GasSafe engineer. However Dovre recommend that this task is undertaken by a suitably competent person.
- 4.2 This upgrade can be fitted before or after installation but if side clearances are limited then it will be easier to upgrade the appliance before installation. Full instructions are included with the kit.

Standard Remote Control (PART NUMBER 8455)

- 4.3 This remote control can control the gas appliance after the pilot has been lit. It can turn the main burner on and regulate it from low through to high and back again. It can turn the main burner off leaving the pilot burning.

Thermostatic and Timer Remote Control (PART NUMBER 8456)

- 4.4 This remote control can control the gas appliance after the pilot has been lit.

MANUAL MODE

Can be used to turn the main burner on and manually regulate it from low through to high and back again. It can also be used to turn the main burner off leaving the pilot burning.

AUTO MODE

Will automatically regulate the room to a pre-set temperature.

TIMER MODE

Will turn the appliance on and off according to a pre-set programme and automatically regulate the room temperature during the two on periods.

5. Cleaning the Appliance

! **WARNING: NEVER CLEAN THE APPLIANCE WHILE IT'S HOT. THE APPLIANCE STAYS HOT FOR A LONG TIME AFTER SHUTDOWN.**

IMPORTANT: THE OUTER PANNELLING OF THE APPLIANCE IS MADE FROM CAST IRON. USE CAUTION WHEN INSTALLING, REMOVING AND STORING AS THE COMPONENTS ARE HEAVY AND SHOULD BE HANDLED CAREFULLY.

- 5.1 Make sure the appliance and surrounds are cool before cleaning.

REMOVING THE DOOR

- 5.2 For rear flue exit lift the top of the appliance off and put to one side.
- 5.3 For top flue exit lift and support the top to give clearance, see Diagram 2.

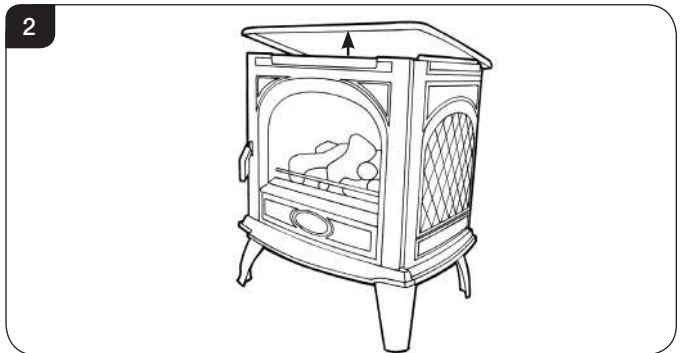

- 5.4 Lift the front upwards until it is clear of the slots and pull away from the appliance, see Diagram 3.

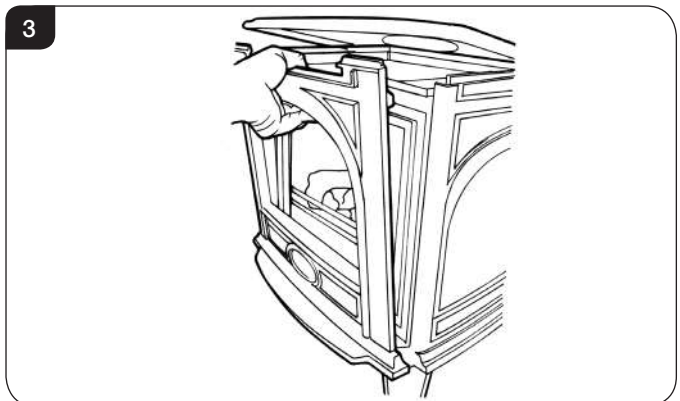

User Instructions

5.5 Remove the glass frame by undoing the fixing screws and lifting clear, see Diagram 4. **Take care to support the glass window panel when removing the screws.**

5.6 Place carefully to one side.

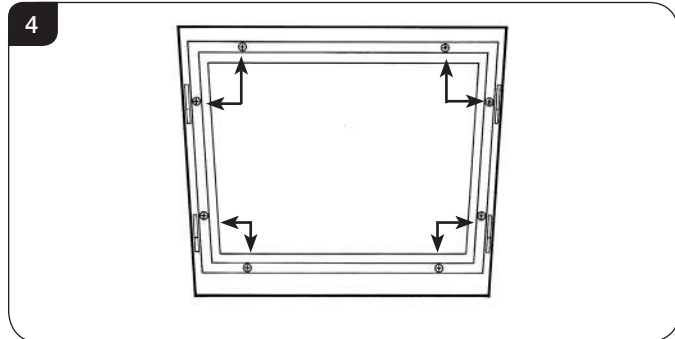

5.7 Carefully remove the ceramic fuel bed components and set aside. Protect the floor coverings and follow the advice given in Section 6.

5.8 The logs do not require cleaning. Do not use a vacuum cleaner or brush to clean the coals, any large pieces of debris can be removed by hand.

5.9 Ensure any debris is removed from the burner ports.

5.10 Replace the ceramics, see Section 7.

The glass frame must be refitted to the appliance following cleaning or servicing.

5.11 Ensure that the rope seal on the back of the glass frame is intact and replace the screws working from the top down. Tighten the screws evenly **DO NOT OVER TIGHTEN**, see Diagram 4.

5.12 Replace ALL of the securing screws ensuring that a screw is present in all fixing slots.

! UNDER NO CIRCUMSTANCES SHOULD THE APPLIANCE BE USED IF ANY OF THE GLASS FRAME RETAINING SCREWS ARE LOOSE OR MISSING.

5.13 With the top still supported or removed refit front by locating in grooves and lowering into place, see Diagram 3.

5.14 Replace top, see Diagram 2.

NEVER OPERATE THE APPLIANCE WHEN THE GLASS FRAME IS REMOVED, OR THE GLASS IS BROKEN.

5.15 Use a damp cloth to clean the outer casing of the appliance.

6. Arrangement of Fuel Bed

Advice on handling and disposal of fire ceramics



The fuel effect of this appliance is made from Refractory Ceramic Fibre (RCF), a material which is commonly used for this application.

Protective clothing is not required when handling these articles, but we recommend you follow normal hygiene rules of not smoking, eating or drinking in the work area and always wash your hands before eating or drinking.

To ensure that the release of RCF fibres are kept to a minimum, during installation and servicing a HEPA filtered vacuum is recommended to remove any dust accumulated in and around the appliance before and after working on it. When servicing the appliance it is recommended that the replaced items are not broken up, but are sealed within heavy duty polythene bags and labelled as RCF waste.

RCF waste is classed as stable, non-reactive hazardous waste and may be disposed of at a licensed landfill site.

Excessive exposure to these materials may cause temporary irritation to eyes, skin and respiratory tract; wash hands thoroughly after handling the material.

7. Log Layout

LOGS MUST BE POSITIONED ACCORDING TO THE FOLLOWING INSTRUCTIONS TO GIVE THE CORRECT FLAME EFFECT

The logs for the fuel bed are clearly individually labelled, A to D.

7.1 Ensure the burner tray is clean and free from any debris, see Diagram 5.

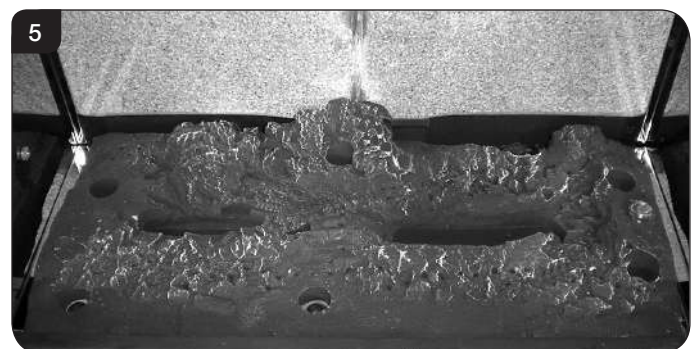

User Instructions

7.2 There are 3 embers. Place 2 embers in the back corners of the burner, resting in the cut outs, see Diagram 6. Place the last ember loosely at the front of the fuel bed to cover the hole in the centre.

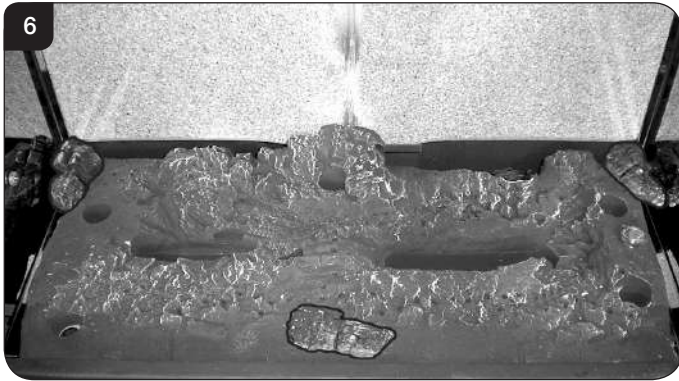

7.3 Place Log D on the left hand side of the burner. There is a hole on the underside of Log D which fits over the raised stud on the left of the burner. The back of the log should rest flat against the back panel, see Diagram 7.

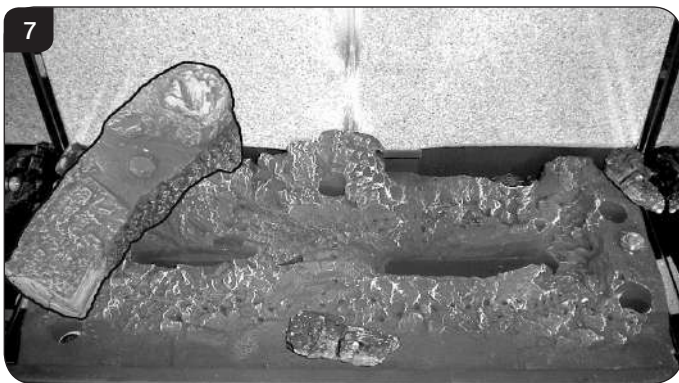

7.4 Place Log B on top of Log D. There is a hole on the underside of Log B which fits over the raised stud on Log D to secure in place. The right hand side of the log rests in the groove in the burner, see Diagram 8.

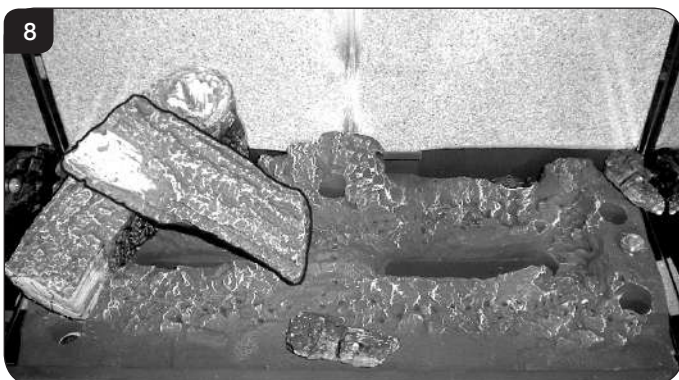

7.5 Place Log C on the right hand side of the burner. There is a hole on the underside of Log C which fits over the raised stud on the right of the burner. The back of the log should rest flush against the back panel, see Diagram 9.

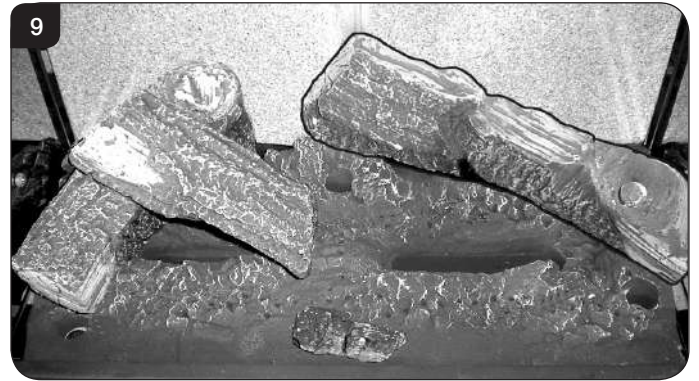

7.6 Place the log guard into position on the grooves on the sides of the firebox, see Diagram 10.



7.7 Place Log A across Log C. There is a hole on the underside of Log A which fits over the raised stud on Log C to secure in place. The small cut out on the left side of the log rests onto the log guard, see Diagram 11.



User Instructions

- 7.8 Once the logs are in place sparingly spread an amount of the Embaglow fibres provided on the sections highlighted, see Diagram 12.
Take care not to use more than half a packet per application.

IT IS ESSENTIAL TO KEEP THE REAR PORT FREE FROM OBSTRUCTION.



- 7.9 Use a ceramic glass product generally sold for cleaning ceramic hobs to clean the glass front.

The glass frame must be refitted to the appliance following cleaning or servicing.

- 7.10 Ensure that the rope seal on the back of the glass frame is intact and replace the screws working from the top down. Tighten the screws evenly **DO NOT OVER TIGHTEN**, see Diagram 13.

NEVER OPERATE THE APPLIANCE WHEN THE GLASS FRAME IS REMOVED, OR THE GLASS IS BROKEN.

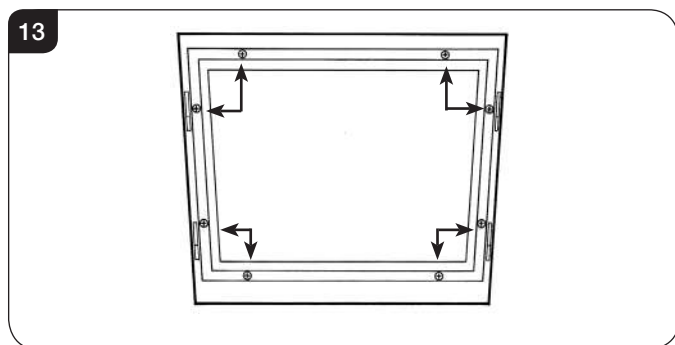

- 7.11 Replace ALL of the securing screws ensuring that a screw is present in all fixing slots.



UNDER NO CIRCUMSTANCES SHOULD THE APPLIANCE BE USED IF ANY OF THE GLASS FRAME RETAINING SCREWS ARE LOOSE OR MISSING.

NEVER OPERATE THE APPLIANCE WHEN THE GLASS FRAME IS REMOVED, OR THE GLASS IS BROKEN.

- 7.12 With the top still supported or removed refit front by locating in grooves and lowering into place, see Diagram 14.

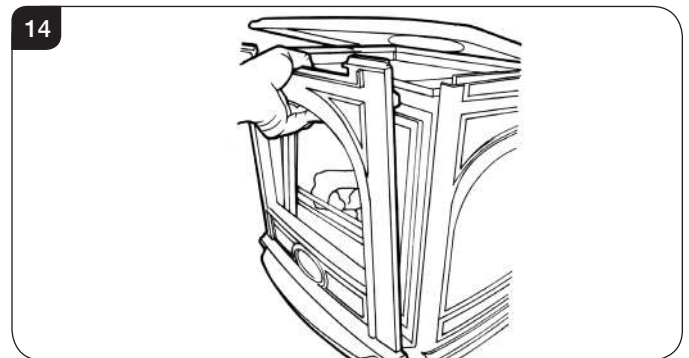

- 7.13 Now replace top, see Diagram 15.

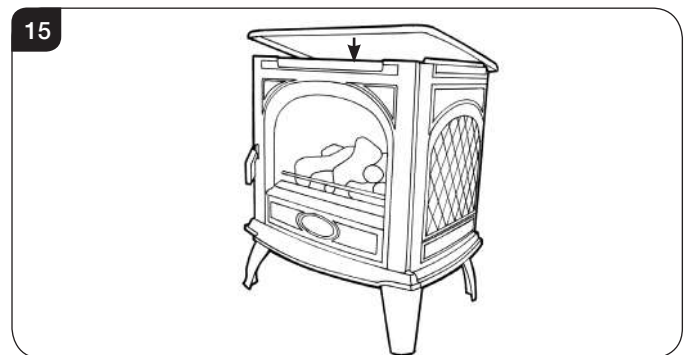

8. Flue Sure System

- 8.1 The appliance is fitted with a Flue Sure System, which will act to cut off the gas supply to the burners in the event of incorrect operation of the flue. If the system acts to cut off the gas supply, this indicates that there is insufficient flue pull. If this occurs a minimum of 10 minutes should be allowed before trying to relight. Continued operation of this safety device means there may be a serious problem with the flue system. A qualified GasSafe engineer should inspect this.

DO NOT USE THE APPLIANCE UNTIL AN ENGINEER SAYS IT IS SAFE TO DO SO.

9. Flame Failure Device

- 9.1 This is a safety feature incorporated on this appliance which automatically switches off the gas supply if the pilot goes out and fails to heat the thermocouple.

IF THIS OCCURS DO NOT ATTEMPT TO RELIGHT THE APPLIANCE FOR 3 MINUTES.

10. Running In

- 10.1 During initial use of a new Dovre appliance a strong odour will be encountered as various surface coatings become hot for the first time. Although these odours are harmless it is recommended that the appliance is operated on maximum for 4 to 8 hours in order to fully burn off these coatings. After this period the odours should then disappear.

If the odours persists, please contact your installer for advice.

- 10.2 During the first few hours of burning there may be discolouration of the flames. This will also disappear after a short period of use.

11. Servicing

- 11.1 The appliance must be serviced every 12 months by a qualified GasSafe Engineer. In all correspondence always quote the Model number and the Serial number which may be found on the Commissioning Checklist (Page 3).

12. Ventilation

- 12.1 Any purpose provided ventilation should be checked periodically to ensure that it is free from obstruction.

13. Installation Details

- 13.1 Your installer should have completed the commissioning sheet at the front of this book. This records the essential installation details of the appliance. In all correspondence always quote the Model number and Serial number.

14. Hot Surfaces

- 14.1 Parts of this appliance become hot during normal use. Regard all parts of the appliance as a 'working surface'.
- 14.2 Provide a suitable fire guard to protect young children and the infirm.

Installation Instructions

Technical Specification

Covering the following models:

Model	NATURAL GAS	LPG
Dovre 425	DV541-124	DV541-447

Model	Gas CAT.	Gas Type	Working Pressure	Aeration	Injector	Gas Rate m ³ /h	Input kW (Gross)		Country
							High	Low	
Dovre 425	I ₂ H	Natural (G20)	20mbar	2 x 6mm	067	0.629	6.6	3.9	GB, IE
	I ₃ P	Propane (G31)	37mbar	2 x 13mm	128	0.252	6.7	3.7	GB, IE
Efficiency Class 2 - 78% Net/ NOx Class 4									
Flue Size TOP/REAR EXIT 127mm ø									
Gas Inlet Connection Size = 8mm ø									
Minimum Flue Specification = T250/N2/0/D/1									
Maximum Flue Temp = 220°C									

i The net efficiency of this appliance has been measured as specified in EN613:2001 and the result after conversion to gross using the appropriate factor from Table E4 of SAP 2012 is 70.3%. The test data has been certified by Kiwa Nederland BV. The gross efficiency value may be used in the UK Government's Standard Assessment Procedure (SAP) for energy rating of dwellings.

Installation Instructions

Technical Specification

This appliance has been certified for use in countries other than those stated. To install this appliance in these countries, it is essential to obtain the translated instructions and in some cases the appliance will require modification. Contact Dovre for further information.

PACKING CHECKLIST

Qty	Description	Fixing Kit containing:-
1 x	Stove	1 x Instruction Manual
1 x	Flue Blanking plate	
1 x	Log set (5 logs)*	
1 x	Ash Panel*	
1 x	Embaglow	
*Packed in appliance		

1

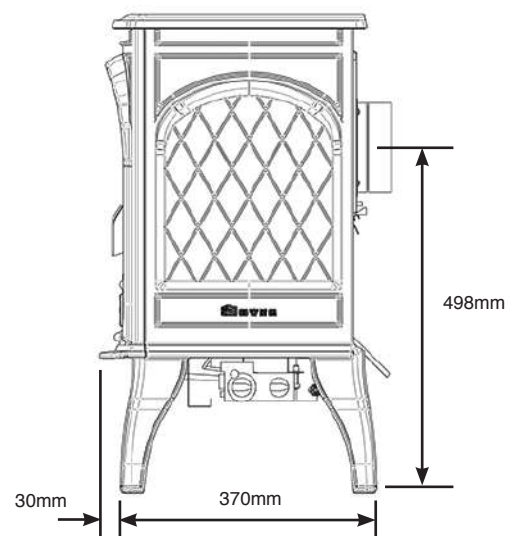
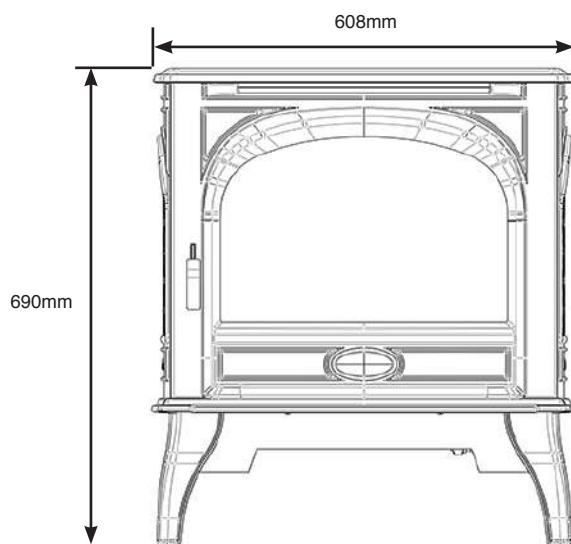
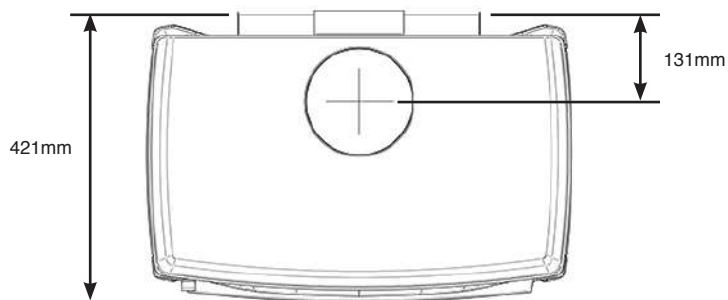

Site Requirements

1. Flue & Chimney Requirements

- 1.1 The chimney or flue system must comply with the rules in force, and must be a minimum of 127mm in diameter. (5").
- 1.2 The minimum flue height for the appliance must be 3 metres (10ft). Any horizontal flue run from the rear outlet must not exceed 100mm from the back of the appliance.
- 1.3 The chimney or flue must be free from any obstruction. Any damper plates must be removed or secured in the fully open position, and no restrictor plates fitted.
- 1.4 The chimney must be swept prior to the installation, but it need not be swept if it can be seen the chimney is clean and unobstructed throughout its entire length.
- 1.5 A5" (127mm) liner must be used if fitting the appliance into an existing brick built chimney. Larger lined flues can work, but in some instances could cause cold start flue problems resulting in nuisance shutdown. Lined flues above 7" (175mm) are not recommended.
- 1.6 The European chimney standards now describe chimneys and flues by their temperature, pressure and resistance to corrosion, condensation and fire. To identify the correct flue system, the minimum flue specification is shown in the Technical Specification. Existing chimneys are not covered by this system.

2. Flue Options

A range of Vitreous Enamel Gloss Black flue pipe is available to compliment the Dovre 425. Please contact your Dovre retailer for further information.

3. Gas Supply

THIS APPLIANCE IS INTENDED FOR USE ON A GAS INSTALLATION WITH A GOVERNED METER.

- 3.1 Before installation, ensure that the local distribution conditions (identification of the type of gas and pressure) and the adjustment of the appliance are compatible.
- 3.2 Ensure the gas supply delivers the required amount of gas and is in accordance with the rules in force.
- 3.3 Soft copper tubing and soft soldered joints must not be closer than 50mm to the base of the burner unit.
- 3.4 A means of isolating the gas supply to the appliance must be provided independent of any appliance control.
- 3.5 All supply gas pipes must be purged of any debris that may have entered prior to connection to the appliance.
- 3.6 The gas supply must be installed in a way that does not restrict the removal of the appliance for servicing and inspection.

4. Ventilation

IMPORTANT: Ensure any national ventilation requirements are taken into account during installation of the appliance.

UK ONLY:

The Dovre 425 has a nominal input not exceeding 7.0kW and does not normally require any additional permanent ventilation.

If however, spillage is detected when commissioning the appliance, there may be insufficient natural ventilation and additional ventilation may be required.

FOR THE REPUBLIC OF IRELAND REFER TO THE RULES IN FORCE FOR VENTILATION REQUIREMENTS.

5. Appliance Location

- 5.1 Building Regulations state this appliance must stand on a non-combustible hearth that is at least 12mm thick and projects 50mm minimum from the base of the appliance in all directions, however Dovre recommend the hearth extends to the following dimensions, see Diagram 1.

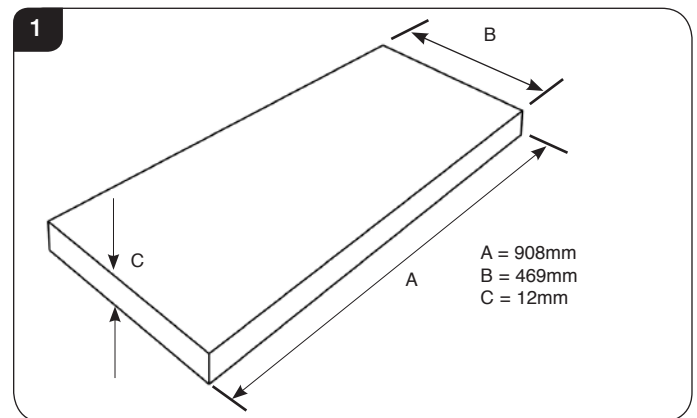

- 5.2 Do not install in a room that contains a bath or shower.

Installation Instructions

Site Requirements

MINIMUM CLEARANCE

5.3 The appliance is not suitable for installation against a combustible wall. All combustible materials must be removed from behind the appliance.

5.4 **Ensure that all minimum clearances to combustible materials are complied with, see Diagrams 2 & 3.**

The specified clearances provide the minimum distance to combustible materials. If the appliance is intended to be installed into a non-combustible opening the clearance to the **sides and above** the appliance can be reduced. However, it is recommended that the specified clearances are maintained irrespective of the materials used in the construction of the opening to allow adequate air flow and access to controls. **The clearance at the rear of the appliance must always be a minimum of 50mm.**

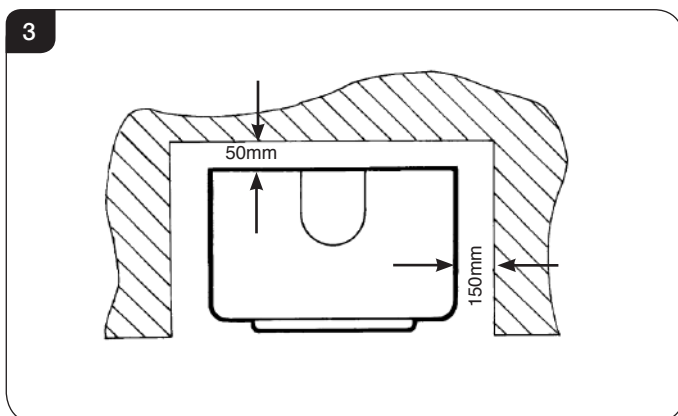
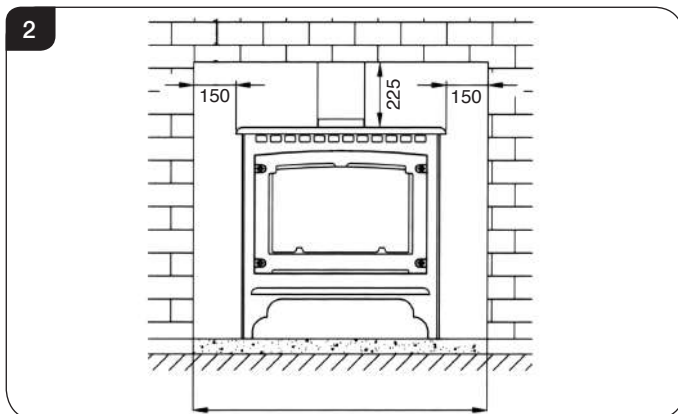

5.5 **In a non-combustible recess be careful to allow enough clearance at the sides and rear of the appliance to perform spillage tests and reach the controls.**

Installation Instructions

1. Safety Precautions

- 1.1 For your own and other's safety, you must install this appliance according to local and national codes of practice. Failure to install the appliance correctly could lead to prosecution. **Read these instructions before installing and using this appliance.**
- 1.2 These instructions must be left intact with the user.
- 1.3 Do not attempt to burn rubbish on this appliance.
- 1.4 Keep all plastic bags away from young children.
- 1.5 Do not place any object on or near to the appliance and allow adequate clearance above the appliance.

IF THE APPLIANCE IS EXTINGUISHED OR GOES OUT IN USE, WAIT 3 MINUTES BEFORE ATTEMPTING TO RELIGHT THE APPLIANCE.

- 1.6 The appliance is fitted with a Flue Sure System, which will act to cut off the gas supply to the burners in the event of incorrect operation of the flue. If the system acts to cut off the gas supply, this indicates that there is insufficient flue pull. If this occurs a minimum of 10 minutes should be allowed before trying to relight. Continued operation of this safety device means there may be a serious problem with the flue system. A qualified GasSafe engineer should inspect this.
- 1.7 Do not alter or tamper with the Flue Sure System. Use only genuine replacement parts when servicing the system - refer to the Servicing **Section, Replacing Parts.**

DO NOT USE THE APPLIANCE UNTIL AN ENGINEER SAYS IT IS SAFE TO DO SO.



IMPORTANT: REFER TO DATA BADGE AND TECHNICAL SPECIFICATION AT THE FRONT OF THE MANUAL TO ENSURE THE APPLIANCE IS CORRECTLY ADJUSTED FOR THE GAS TYPE AND CATEGORY APPLICABLE IN THE COUNTRY OF USE.

FOR DETAILS OF CHANGING BETWEEN GAS TYPES REFER TO SERVICING, SECTION 14, REPLACING PARTS.

Unpacking

- 1.8 Remove the appliance from its packaging, and check that it is complete and undamaged.

Put the loose ceramic parts to one side so that they are not damaged during installation.

2. Upgrading the Appliance

- 2.1 The appliance is fitted with a control valve that can easily be upgraded to battery powered remote control. There are two versions of this control which can be obtained through your local Dovre retailer. There is no requirement for this upgrade to be carried out by an approved GasSafe engineer. However Dovre recommend that this task is undertaken by a suitably competent person.
- 2.2 This upgrade can be fitted before or after installation but if side clearances are limited then it will be easier to upgrade the appliance before installation. Full instructions are included with the kit.

Standard Remote Control (PART NUMBER 8455)

- 2.3 This remote control can control the gas appliance after the pilot has been lit. It can turn the main burner on and regulate it from low through to high and back again. It can turn the main burner off leaving the pilot burning.

Thermostatic and Timer Remote Control (PART NUMBER 8456)

- 2.4 This remote control can control the gas appliance after the pilot has been lit.

MANUAL MODE

Can be used to turn the main burner on and manually regulate it from low through to high and back again. It can also be used to turn the main burner off leaving the pilot burning.

AUTO MODE

Will automatically regulate the room to a pre-set temperature.

TIMER MODE

Will turn the appliance on and off according to a pre-set programme and automatically regulate the room temperature during the two on periods.

3. Installation of the Appliance

- 3.1 Decide whether to use top or rear flue exit. The appliance is factory built for rear flue exit but it can be changed to top exit by swapping the flue spigot and blanking plate located on the appliance.
- 3.2 Position the appliance ensuring all appropriate clearances are observed.
- 3.3 Having run the gas supply to the appliance **PURGE THE SUPPLY PIPE.** This is essential to expel any debris that can block the gas controls.

Installation Instructions

- 3.4 Connect the gas supply to the 8mm compression elbow at the right-hand rear corner of the appliance
There is a cutout in the right-hand rear leg to enable a straight connection to the rear of the appliance, see Diagram 1.

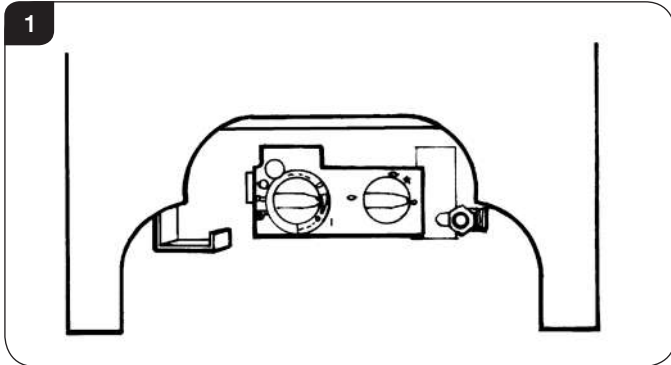

- 3.5 The flue system can now be connected to the appliance.
3.6 Ensure all joints are sealed with a fire resistant cement and use a self-tapping screw at the flue spigot joint.

4. Gas Soundness Pressure Check

- 4.1 Connect a suitable pressure gauge to the test point located on the inlet fitting and turn the gas supply on. Light the appliance and check all gas joints for possible leaks. Turn the appliance to maximum and check that the supply pressure is as stated on the databadge. Turn the gas off and replace the test point screw, turn the gas on and check the test point for leaks.

5. Removing the Door



IMPORTANT: THE OUTER PANNELLING OF THE APPLIANCE IS MADE FROM CAST IRON. USE CAUTION WHEN INSTALLING, REMOVING AND STORING AS THE COMPONENTS ARE HEAVY AND SHOULD BE HANDLED CAREFULLY.

- 5.1 For rear flue exit lift the top of the appliance off and put to one side.
5.2 For top flue exit lift and support the top to give clearance, see Diagram 2.

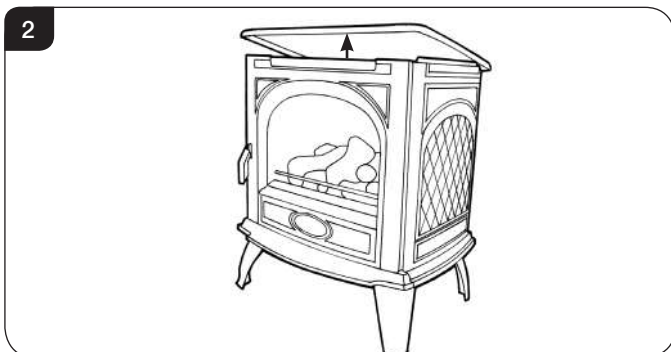

- 5.3 Lift the front upwards until it is clear of the slots and pull away from the appliance, see Diagram 3.

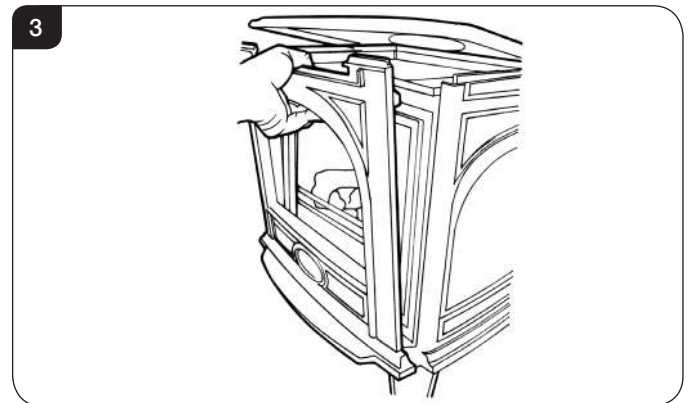

- 5.4 Remove the glass frame by undoing the fixing screws and lifting clear, see Diagram 4. **Take care to support the glass window panel when removing the screws.**

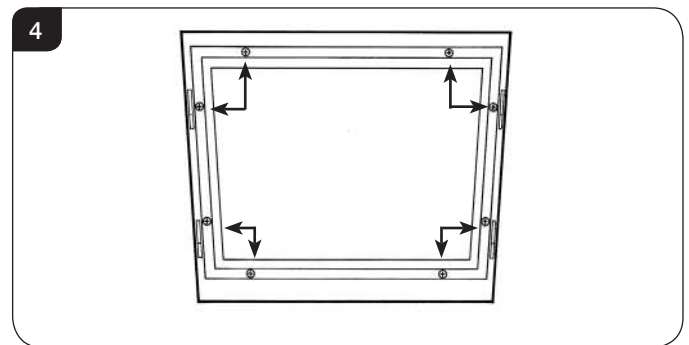

- 5.5 Place carefully to one side.

Installation Instructions

6. Arrangement of Fuel Bed

Advice on handling and disposal of fire ceramics



The fuel effect of this appliance is made from Refractory Ceramic Fibre (RCF), a material which is commonly used for this application.

Protective clothing is not required when handling these articles, but we recommend you follow normal hygiene rules of not smoking, eating or drinking in the work area and always wash your hands before eating or drinking.

To ensure that the release of RCF fibres are kept to a minimum, during installation and servicing a HEPA filtered vacuum is recommended to remove any dust accumulated in and around the appliance before and after working on it. When servicing the appliance it is recommended that the replaced items are not broken up, but are sealed within heavy duty polythene bags and labelled as RCF waste.

RCF waste is classed as stable, non-reactive hazardous waste and may be disposed of at a licensed landfill site.

Excessive exposure to these materials may cause temporary irritation to eyes, skin and respiratory tract; wash hands thoroughly after handling the material.

7. Log Layout

LOGS MUST BE POSITIONED ACCORDING TO THE FOLLOWING INSTRUCTIONS TO GIVE THE CORRECT FLAME EFFECT

The logs for the fuel bed are clearly individually labelled, A to D.

- 7.1 Ensure the burner tray is clean and free from any debris, see Diagram 5.

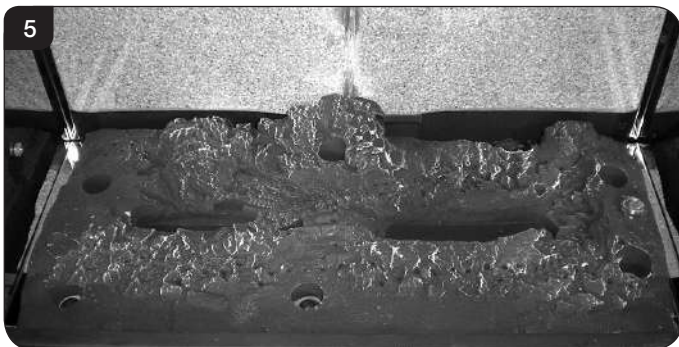

- 7.2 There are 3 embers. Place 2 embers in the back corners of the burner, resting in the cut outs, see Diagram 6. Place the last ember loosely at the front of the fuel bed to cover the hole in the centre.

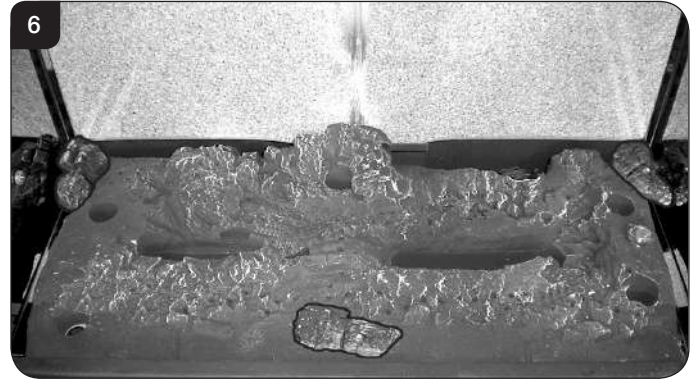

- 7.3 Place Log D on the left hand side of the burner. There is a hole on the underside of Log D which fits over the raised stud on the left of the burner. The back of the log should rest flat against the back panel, see Diagram 7.

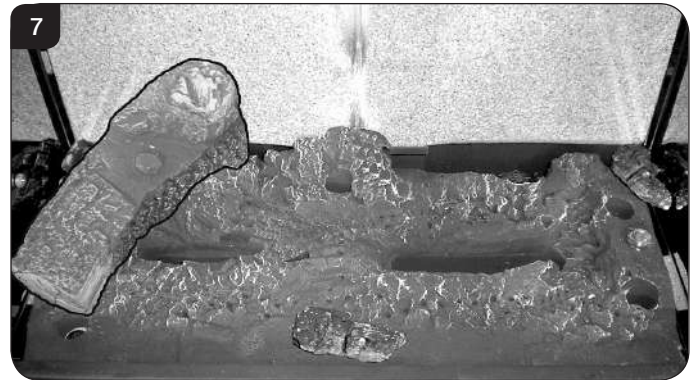

- 7.4 Place Log B on top of Log D. There is a hole on the underside of Log B which fits over the raised stud on Log D to secure in place. The right hand side of the log rests in the groove in the burner, see Diagram 8.

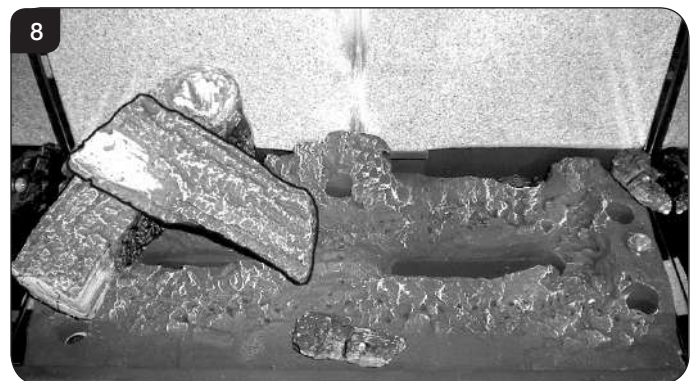

Installation Instructions

7.5 Place Log C on the right hand side of the burner. There is a hole on the underside of the burner which fits over the raised stud on the right of the burner. The back of the log should rest flush against the back panel, see Diagram 9.

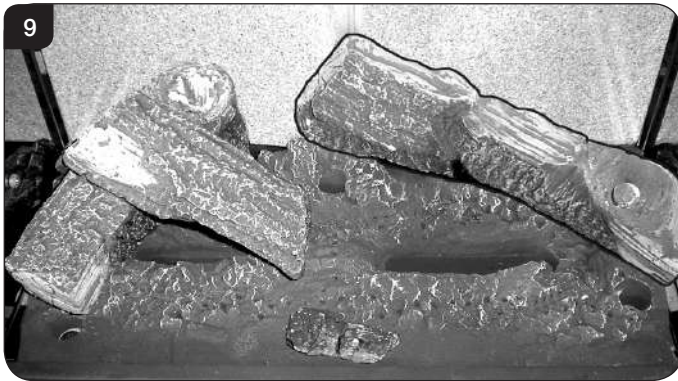

7.6 Place the log guard into position on the grooves on the sides of the firebox, see Diagram 10.



7.7 Place Log A across Log C. There is a hole on the underside of Log A which fits over the raised stud on Log C to secure in place. The small cut out on the left side of the log rests onto the log guard, see Diagram 11.



7.8 Once the logs are in place sparingly spread an amount of the Embaglow fibres provided on the sections highlighted, see Diagram 12. Take care not to use more than half a packet per application.

IT IS ESSENTIAL TO KEEP THE REAR PORT FREE FROM OBSTRUCTION.



7.9 Use a ceramic glass product generally sold for cleaning ceramic hobs to clean the glass front.

The glass frame must be refitted to the appliance following cleaning or servicing.

8. Completion of Assembly

8.1 Ensure that the rope seal on the back of the glass frame is intact and replace the screws working from the top down. Tighten the screws evenly **DO NOT OVER TIGHTEN**, see Diagram 13.

NEVER OPERATE THE APPLIANCE WHEN THE GLASS FRAME IS REMOVED, OR THE GLASS IS BROKEN.

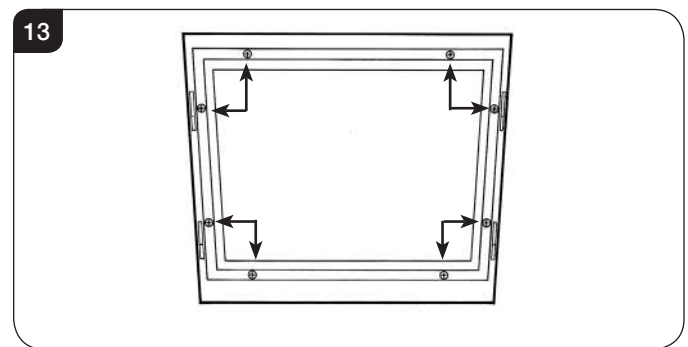

8.2 Replace ALL of the securing screws ensuring that a screw is present in all fixing slots.

! UNDER NO CIRCUMSTANCES SHOULD THE APPLIANCE BE USED IF ANY OF THE GLASS FRAME RETAINING SCREWS ARE LOOSE OR MISSING.

Installation Instructions

- 8.3 With the top still supported or removed refit front by locating in grooves and lowering into place, see Diagram 14.

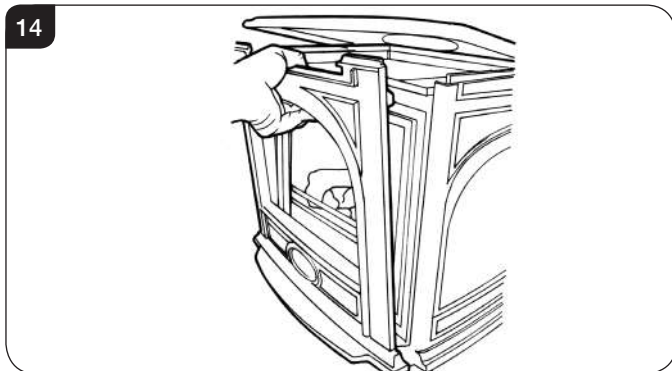

- 8.4 Now replace top, see Diagram 15.

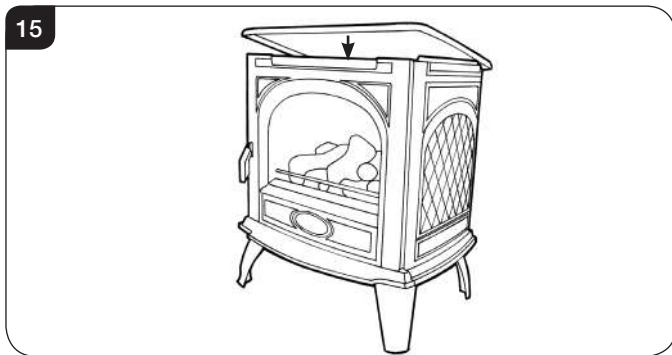

9. Operating the Appliance

- 9.1 The control valve is at the foot on the right-hand side of the appliance. It has two controls, see Diagram 16:

1. The right-hand knob controls the pilot ignition
2. The left-hand knob controls the main burner

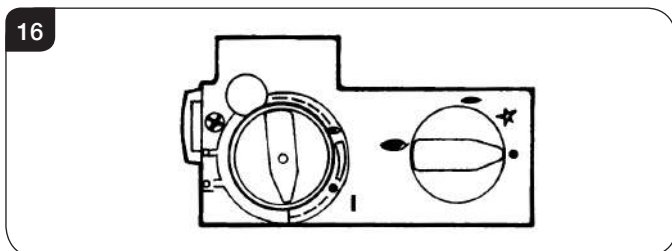

- 9.2 Refer to separate instructions if your appliance is upgraded to include battery remote control. The instructions below apply whether or not you have the remote upgrade.

Lighting the Pilot

- 9.3 To start the left-hand and right-hand control knobs must both point to off (●):
- 9.4 Press in the right-hand control knob and rotate anti-clockwise until a click is heard. Continue to press in. The knob points to the pilot (←).

The pilot is lit.

- 9.5 Keep the knob depressed for 10 seconds before releasing. The pilot remains lit.

Repeat the above steps if the pilot does not stay lit.

NOTE: If the pilot goes out, the Interlock system prevents you lighting again for a short period.

- 9.6 If, after repeating the above steps the pilot does not light, contact your Retailer or Installer.
- 9.7 Turn the right-hand knob to the left to main burner setting (→).

Adjusting the Flame height

- 9.8 You can now adjust the flame height and temperature using the left-hand control knob.
- 9.9 Turn the left-hand knob anti-clockwise to increase the flame height.
- 9.10 Turn clockwise to decrease the height.



IMPORTANT: YELLOW FLAMES TYPICALLY APPEAR WHEN THE APPLIANCE HAS REACHED NORMAL OPERATING TEMPERATURE. THIS CAN TAKE UP TO 30 MINUTES.



WARNING: IF THE APPLIANCE FAILS TO LIGHT OR BECOMES EXTINGUISHED IN USE, WAIT 3 MINUTES BEFORE ATTEMPTING TO RELIGHT.

1. Commissioning

- 1.1 Close all doors and windows in the room.
- 1.2 Ignite the appliance and operate on maximum for 10 minutes.
- 1.3 Position a lighted smoke match just inside the draught diverter opening at the rear of the appliance.
- 1.4 Check all smoke is drawn into the opening, see Diagram 1.

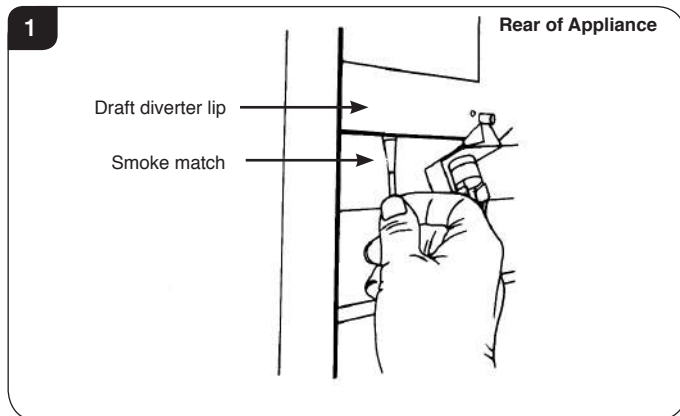

- 1.5 If there is any doubt, run the appliance for a further 10 minutes, and repeat the test.
- 1.6 If there are any extractor fans in adjacent rooms, the test must be repeated with the fans running on maximum and interconnecting doors open.

IF SPILLAGE PERSISTS, DISCONNECT THE APPLIANCE AND SEEK EXPERT ADVICE.

- 1.7 Complete the Commissioning Checklist at the front of this manual covering:
 - Flue checks
 - Gas checks
 - Log layout - flame picture
- 1.8 Upon completion of the commissioning and testing of the installation and correct operation of the appliance, the installer must instruct the user how to operate the appliance.
- 1.9 Guide the user through the User Instructions paying particular attention to:
 - a) Regular servicing (Section 11 of the User Instructions).
 - b) Ventilation (Section 12 of the User Instructions) - point out the ventilation positions where applicable.
 - c) Hot surfaces (Section 14 of the User Instructions).

Servicing Instructions

Servicing/Fault Finding Charts

1. Servicing Requirements

IMPORTANT – The glass panel on this appliance should be checked for any signs of damage on the front face of the glass panel (scratches, scores, cracks or other surface defects). If damage is observed, the glass panel must be replaced and the appliance must not be used until a replacement is installed. Under no circumstances should the appliance be used if any damage is observed. Please isolate the appliance until a replacement glass panel has been obtained and installed. Replacement glass panels can be purchased from Dovre via the retailer from which the appliance was purchased or any other Dovre distributor.

This appliance must be serviced at least once a year by a competent person.

All tests must be carried out in accordance with the current GasSafe recommendations.

1.1 Before Testing:

- Conduct a gas soundness test for the property ensuring there are no leaks before servicing.
- Check the operation of the appliance before testing.

1.2 Special checks:

- Clean the burner using a vacuum cleaner with a soft brush attachment. Ensure all debris is removed from the burner ports.

- Clean away lint or fluff from the pilot.
- Clean away lint or fluff from under the burner.
- Check the spark gap on the pilot is correct, see Diagram 1.
- Ensure that the glass frame is secured correctly and that all retaining screws are in place.

1.3 Correct any faults found during the initial test.

1.4 Re-commission the appliance in accordance with Commissioning Procedures.

1.5 Advise the customer of any remedial work undertaken.

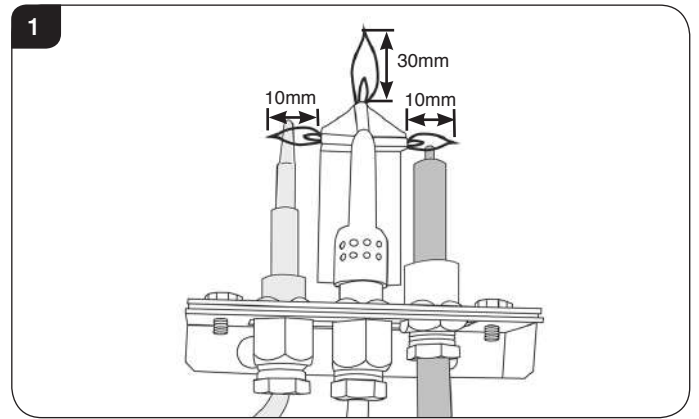

IGNITION FUNCTIONAL CHECK 1

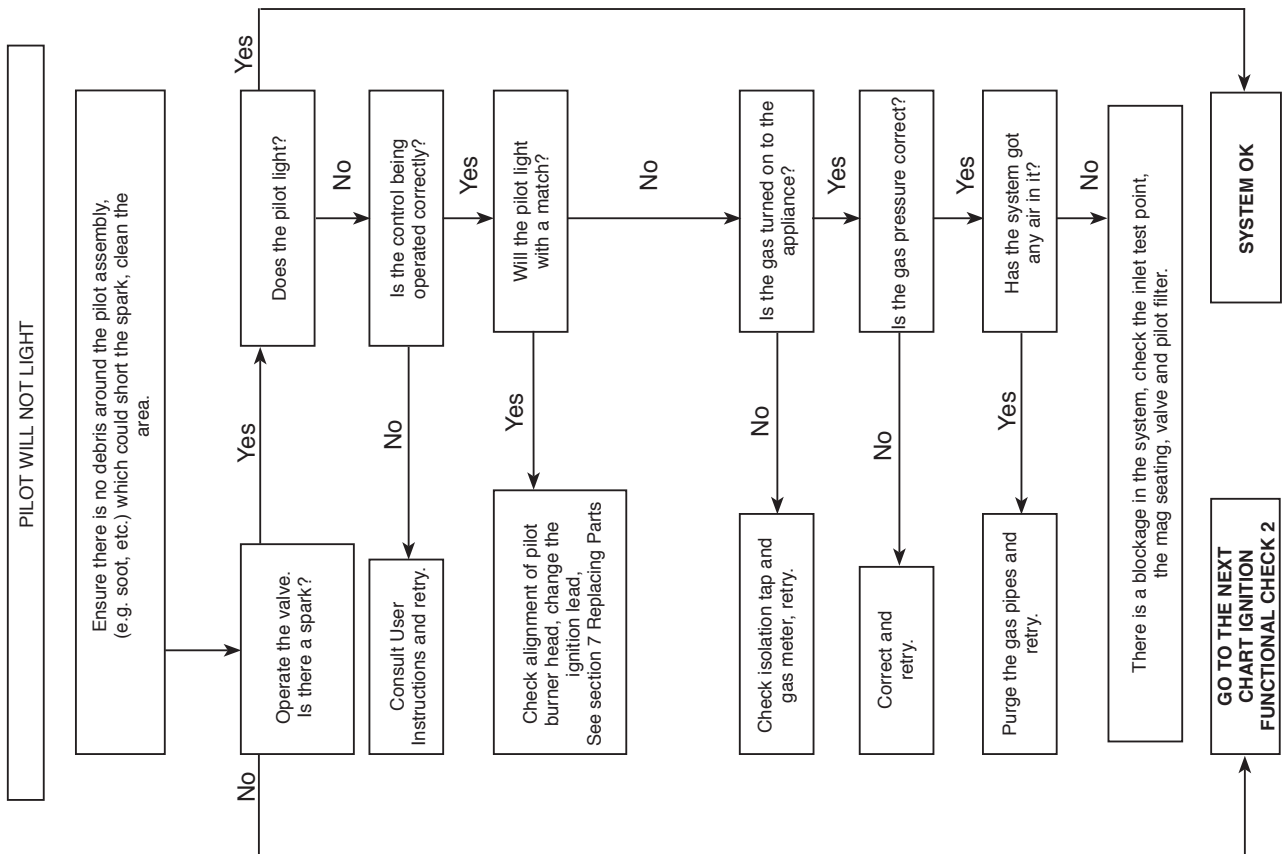

Servicing Instructions

Fault Finding Charts

FLAME FAILURE FUNCTIONAL CHECK 3

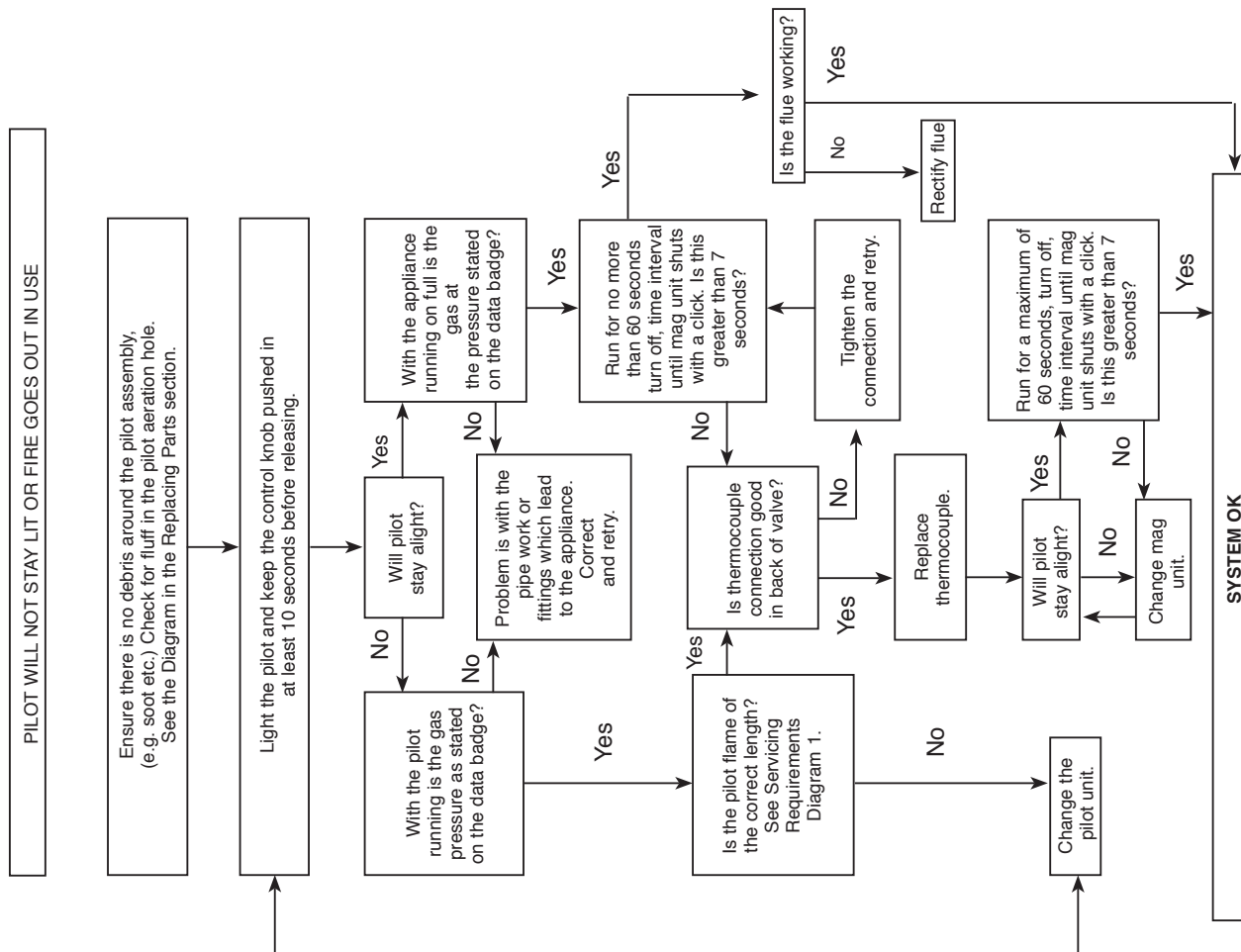

IGNITION FUNCTIONAL CHECK 2

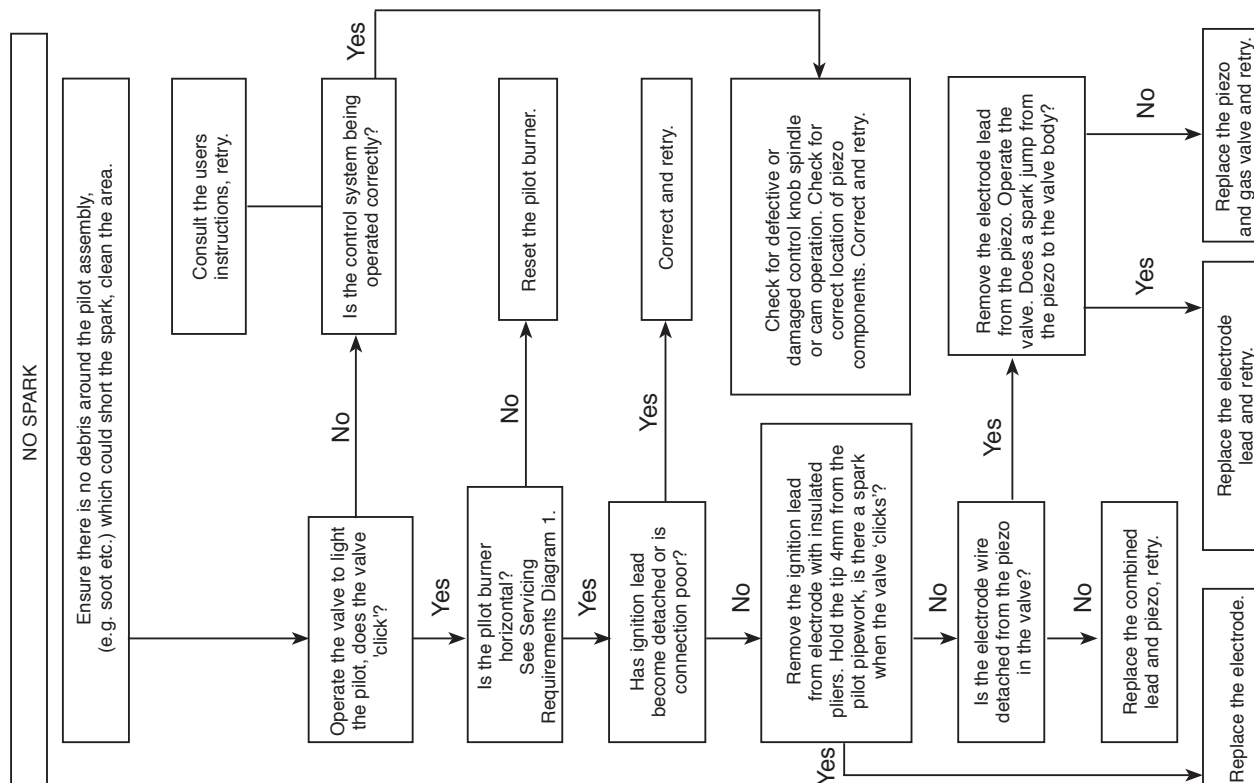

Servicing Instructions - Replacing Parts

1. General

- 1.1 All main components can be replaced without removing the appliance from its installation.
- 1.2 Ensure the appliance and surrounds are cool before servicing.

IT IS ESSENTIAL THAT THE GAS SUPPLY TO THE APPLIANCE IS TURNED OFF AT THE ISOLATION DEVICE BEFORE PROCEEDING FURTHER.

2. Removing the Door



IMPORTANT: THE OUTER PANELLING OF THE APPLIANCE IS MADE FROM CAST IRON. USE CAUTION WHEN INSTALLING, REMOVING AND STORING AS THE COMPONENTS ARE HEAVY AND SHOULD BE HANDLED CAREFULLY.

- 2.1 For rear flue exit lift the top of the appliance off and put to one side.
- 2.2 For top flue exit lift and support the top to give clearance, see Diagram 1.

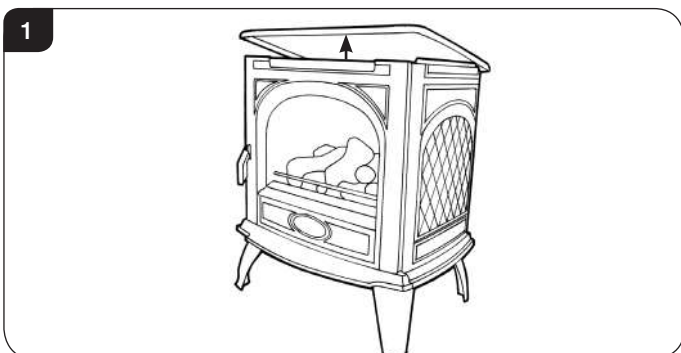

- 2.3 Lift the front upwards until it is clear of the slots and pull away from the appliance, see Diagram 2.

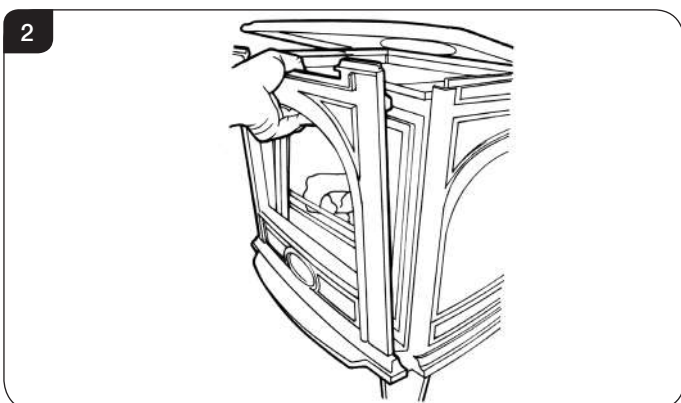

3. Window Frame Assembly

- 3.1 Remove the glass frame by undoing the fixing screws and lifting clear, see Diagram 3. **Take care to support the glass window panel when removing the screws.**

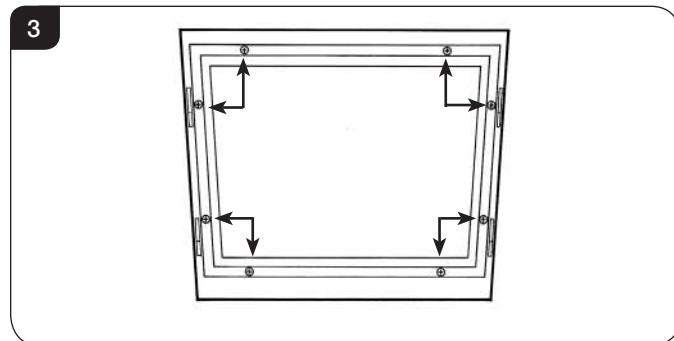

- 3.2 Place carefully to one side.
- 3.3 Carefully remove the ceramic fuel bed components.
- 3.4 Refit in reverse order.
- 3.5 Ensure that the rope seal on the back of the glass frame and replace the screws working from the top down. Tighten the screws evenly **DO NOT OVER TIGHTEN**, see Diagram 3.

NEVER OPERATE THE APPLIANCE WHEN THE GLASS FRAME IS REMOVED OR BROKEN.

- 3.6 Replace ALL of the securing screws ensuring that a screw is present in all fixing slots.



UNDER NO CIRCUMSTANCES SHOULD THE APPLIANCE BE USED IF ANY OF THE GLASS FRAME RETAINING SCREWS ARE LOOSE OR MISSING.

4. Baffle & Ceramic Liners

- 4.1 To access the burner tray and interior workings of the appliance it may be necessary to remove the baffle and the liners.
- 4.2 This appliance has 2 baffles, 1 metal and 1 vermiculite, that must be removed before the liners can be taken out of the appliance.
- 4.3 Remove the logs.

Servicing Instructions - Replacing Parts

METAL BAFFLE

To remove the metal baffle:

- 4.4 Undo the 3 screws securing it to the roof of the firebox, see Diagram 4.

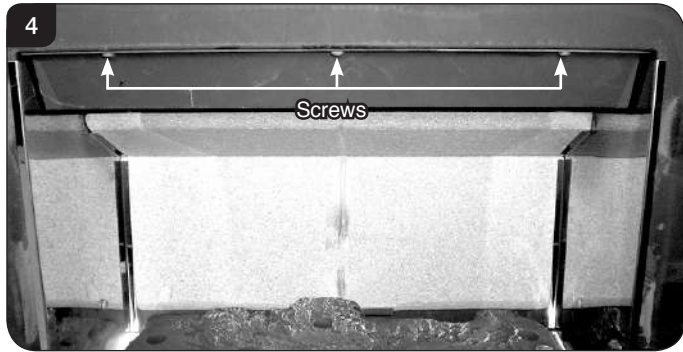

- 4.5 The baffle can now be removed through the front of the appliance.

VERMICULITE BAFFLE

To remove the vermiculite baffle:

- 4.6 Lift the vermiculite baffle and slide out through the front of the appliance, see Diagram 5.

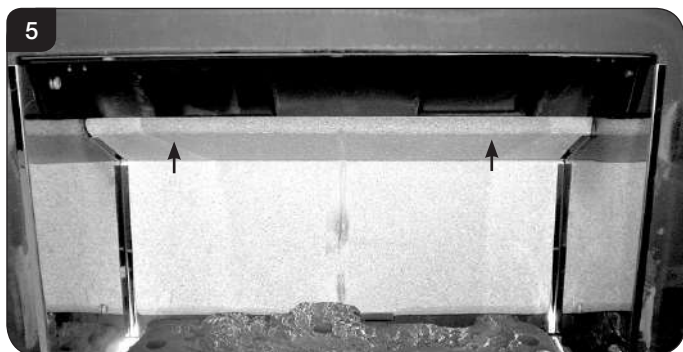

Once the baffles have been placed carefully to one side the liners can then be taken out in the following order.

REFLECTIVE LINERS

- 4.7 To remove the left hand liner undo the 3 screws, including the 1 under the log guard bracket, see Diagram 6.

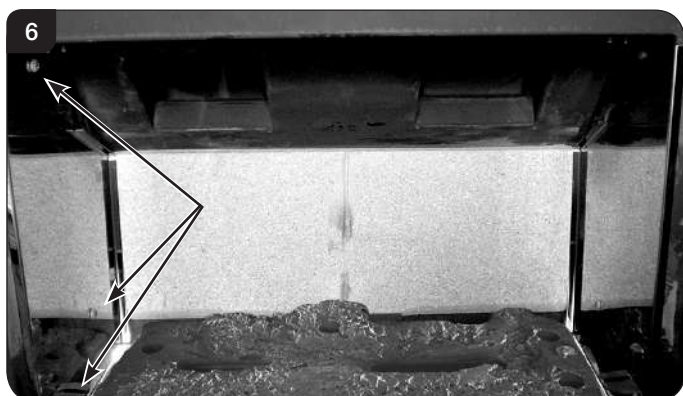

- 4.8 Remove the log guard bracket.

- 4.9 Tilt the liner inwards towards the centre of the firebox before lifting up and pulling out through the front of the firebox, see Diagram 7.

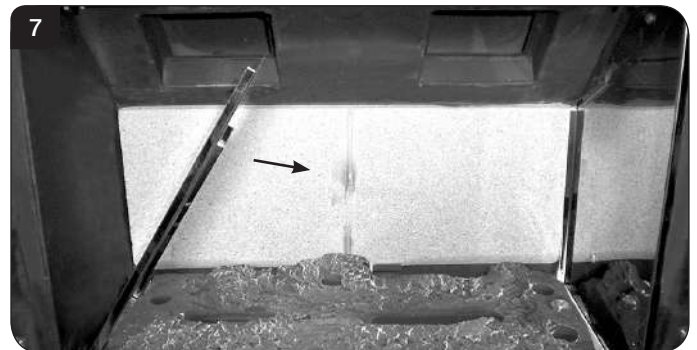

- 4.10 To remove the right hand liner undo the 3 screws, including the 1 under the log guard bracket, see Diagram 6.
- 4.11 Remove the log guard bracket.
- 4.12 Tilt the liner inwards towards the centre of the firebox before lifting up and pulling out through the front of the firebox, see Diagram 7.

VERMICULITE LINER

- 4.13 The rear liner does not need to be removed in order to access the burner tray for maintenance, however it is advisable to remove the rear panel to avoid possible damage and to clean or replace.
- 4.14 To remove the back panel lift out of the bracket and remove through the front of the appliance, see Diagram 8.

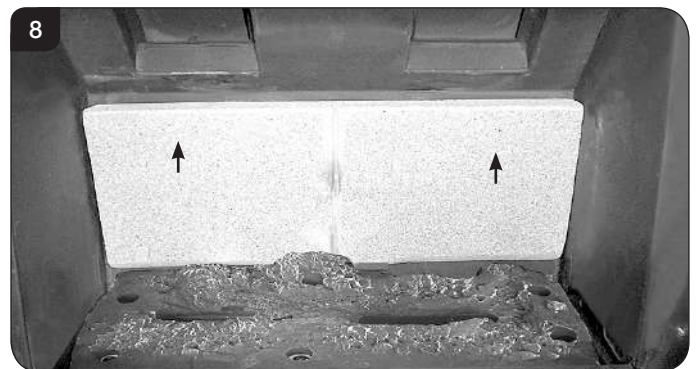

- 4.15 With the liners and baffle removed the firebox is clear for cleaning and maintenance, see Diagram 9.

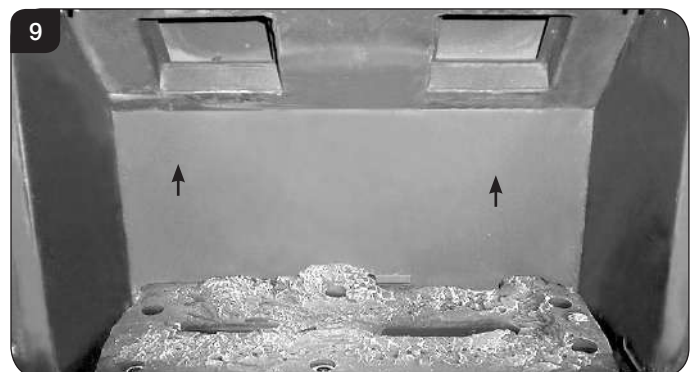

Servicing Instructions - Replacing Parts

5. Main Burner

To replace the main burner:

- 5.1 Remove the baffle and liners, see Section 4.
- 5.2 Lift one side of the burner vertically and manoeuvre out of the firebox, see Diagram 10.

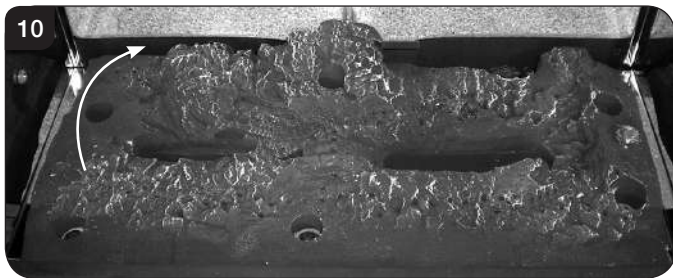

Refit in reverse order.

6. Pilot Unit

- 6.1 The pilot assembly consists of 4 components which can be individually changed:

Pilot burner bracket
Electrode
Pilot injector
Thermocouple

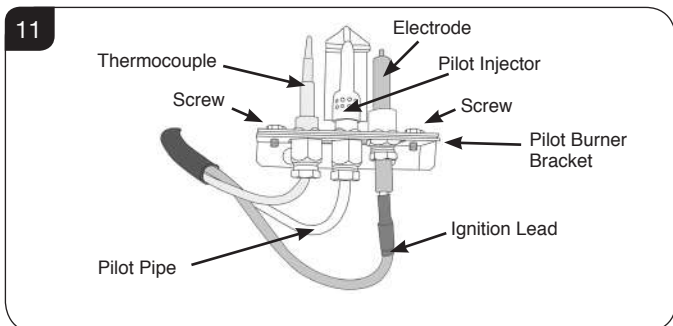

NOTE: Ensure the sealant surrounding the Electrode and Thermocouple leads is replaced if disturbed or removed whilst gaining access to these components.

- 6.2 Turn the gas supply off at the isolation device, remove the door and place to one side, carefully remove the ceramic fuel bed components.

Pilot Burner Bracket

To remove the Pilot Burner Bracket:

- 6.3 **First remove the electrode, pilot pipe and thermocouple as described in the following sections.**
- 6.4 Remove the 2 screws securing the bracket. The pilot burner bracket can now be removed.
- 6.5 Replace in reverse order.

Electrode

- 6.6 Pull the ignition lead off the electrode and undo the retaining nut, see Diagram 11.
- 6.7 Replace with a new electrode. Do not over tighten the nut; this could break the component.
- 6.8 Replace the ignition lead by pushing the spade connector onto the terminal (electrode).

Pilot Injector

- 6.9 Undo the pilot pipe from the gas valve and from the underside of the pilot burner, see Diagram 11.
- 6.10 Remove the pipe and the injector drops out from the burner.

Thermocouple

- 6.11 Disconnect the thermocouple from the gas valve.
- 6.12 Undo the thermocouple nut in the back of the pilot bracket half a turn. This releases the thermocouple.
- 6.13 When replacing with a new thermocouple, take care to bend the new component to the same shape as the thermocouple just removed.
- 6.14 To refit the thermocouple into the pilot bracket, ensure it is pushed fully into the hole. There is a stop on the thermocouple to set the height.
- 6.15 Lock the retaining nut just enough to grip the thermocouple.
- 6.16 Connect the thermocouple to the valve **taking care not to over tighten.**

7. Ignition Lead

- 7.1 Follow the Pilot Unit instruction to access the back of the pilot assembly.
- 7.2 Disconnect the ignition lead from the electrode.
- 7.3 Remove the front cover from the control valve by removing the retaining screw, see Diagram 12 and gently levering clear with flat bladed screwdriver, see Diagram 13.

NOTE: There is a small cylindrical metal spacer inside the cover, this must be kept and replaced on the fixing screw on re-assembly.

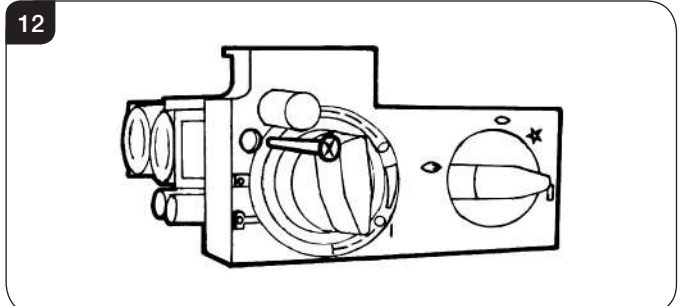

Servicing Instructions - Replacing Parts

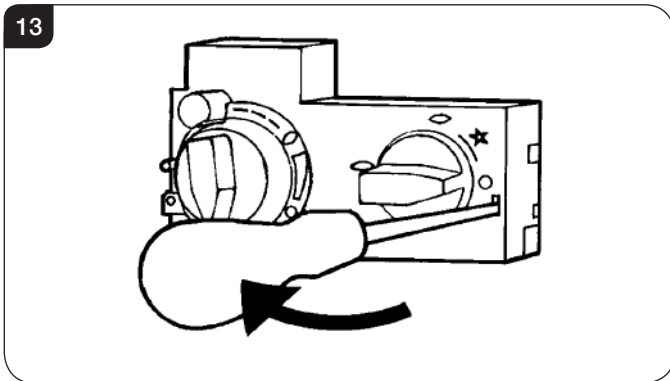

- 7.4 Disconnect the other end of the ignition lead from the valve body noting the route of the ignition lead.
- 7.5 Replace with a new ignition lead following the same route as the old one.

Replace the valve cover and the pilot assembly.
- 7.6 Check operation of the new ignition lead.

8. Piezo

- 8.1 The piezo assembly used on this appliance is not serviceable and is unlikely to fail.
- 8.2 If a new piezo is required it will be necessary to change the valve, see Section 9.

9. Gas Valve

- 9.1 To remove the valve turn off the gas supply at the isolation device.
- 9.2 Disconnect the 2 x 8mm and 1 x 4mm gas pipe fittings at the back of the gas valve, see Diagram 14 (A).
- 9.3 Disconnect the thermocouple, see Diagram 14 (B).

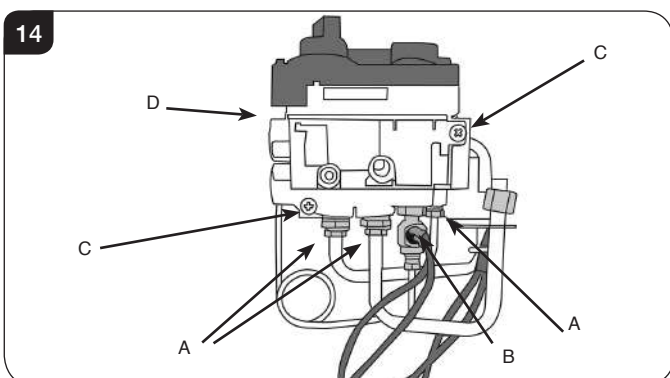

- 9.4 Disconnect the ignition lead from the gas valve, see Diagram 14 (D).
- 9.5 Remove the cover, see Section 7.3.
- 9.6 Undo the two bolts securing the gas valve to the appliance and remove the valve, see Diagram 14 (C).
- 9.7 Replace in reverse order.

- 9.8 Check all joints for gas leaks and check operation of the thermocouple and ignition lead.

10. Magnetic Safety Valve

- 10.1 Turn the gas supply off at the isolation device.
- 10.2 Undo the thermocouple connection from the back of the gas valve, see Diagram 15 (A).
- 10.3 Pull the sensor leads clear and remove the interruptor block, see Diagram 15 (B).
- 10.4 Undo the magnetic valve-retaining nut from the back of the control valve, see Diagram 15 (C).

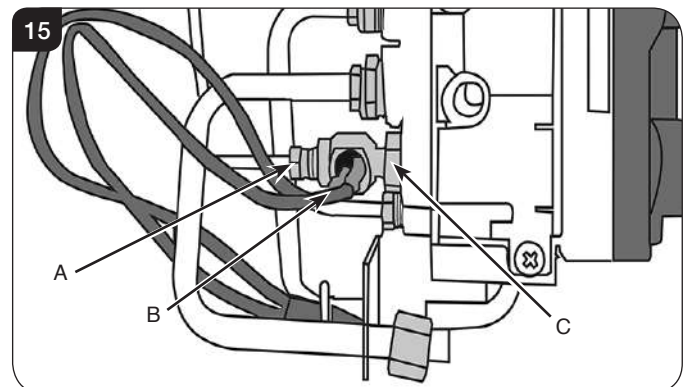

- 10.5 Gently tap out the magnetic valve and replace with a new unit.
- 10.6 Replace the retaining nut and tighten.
- 10.7 Reassemble the interruptor block and leads and secure the thermocouple connection in the rear of the gas control. (Do not over tighten: For best results make sure the nut is finger tight and then give an additional 1/4 turn with a spanner.)
- 10.8 Turn the gas supply on and check the entire pipework and valve joints for any leaks.

11. Main Injector

- 11.1 To remove the main injector turn off the gas supply at the isolation device.
- 11.2 Remove the main burner, see Section 5.
- 11.3 Undo the compression nuts from the feed pipe and the gas valve under the appliance.
- 11.4 Working from inside the firebox remove the lock nut from the injector, see Diagram 16.

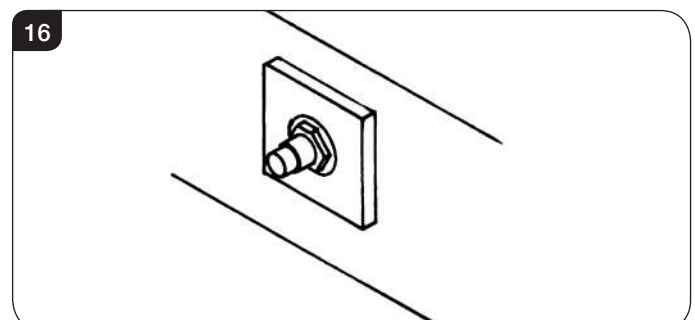

Servicing Instructions - Replacing Parts

- 11.5 Extract the injector with the feed pipe from beneath the appliance.
- 11.6 Holding the injector with a spanner:
- 11.7 Undo the feed pipe. **Note the orientation of the Injector.**
- 11.8 Re-assemble in reverse order.
- 11.9 Turn on the gas supply and check for leaks.

12. Flue Sure System

- 12.1 Open the door and remove the ceramics, placing them carefully to one side.
- 12.2 Remove all the liner panels, the log support bracket and main burner.
- 12.3 Remove the two screws securing the metal panel at the rear of the firebox, see Diagram 17.

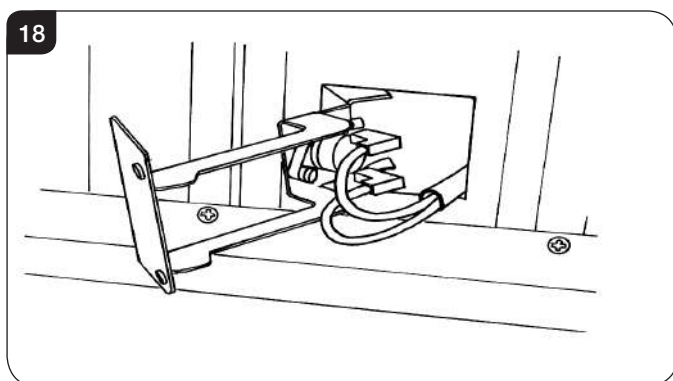
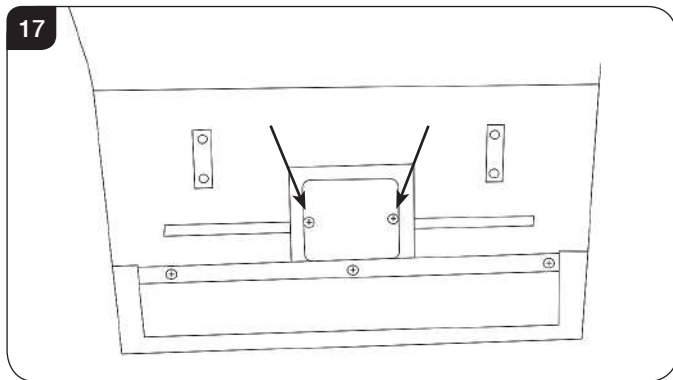

- 12.4 Disconnect the two sensor wires.
- 12.5 Undo the two retaining screws.

- 12.6 Remove the sensor, see Diagram 19.

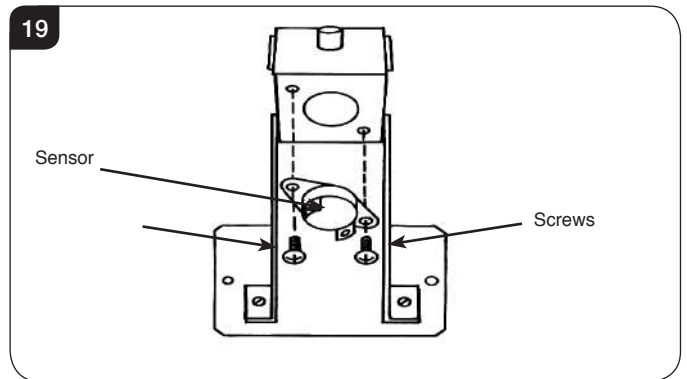

- 12.7 Refit the new sensor.
- 12.8 Refit the leads.
- 12.9 Feed the cable back through the hole as you replace the bracket.
When the bracket is located correctly it sits flush with the back panel without force. If not positioned correctly the bracket sits at an angle, see Diagram 20.

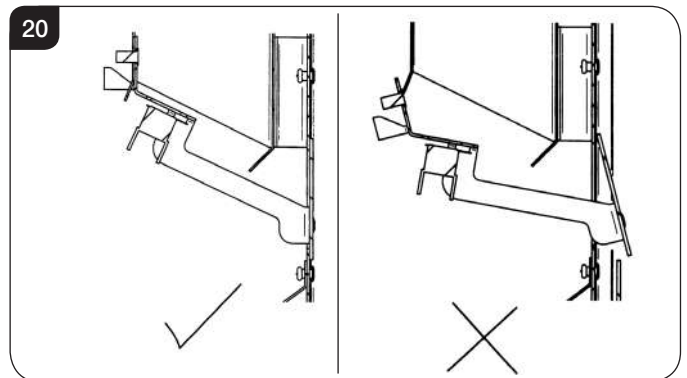

- 12.10 Replace the metal panel. There are spacers on the top edge to ensure the correct distance from the baffle.
These interlock with the rear of the baffle, see Diagram 21.

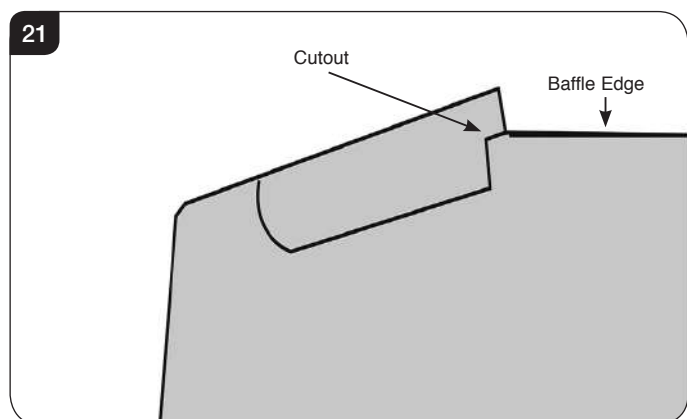

- 12.11 Replace remaining components in reverse order.

Servicing Instructions - Replacing Parts

13. Primary Aeration Plate

NOTE: Not all models have aeration plates. Please refer to the Technical Specification.

- 13.1 To replace the primary aeration plate turn off the gas supply at the isolation device.
- 13.2 Remove the burner, as described in Section 5.
- 13.3 Remove the fixing nuts and slide the plate off the venturi.
- 13.4 Replace with the correct size plate and secure with the nuts. Ensure the lower edge of the plate is located over the venturi flange, see Diagram 22.

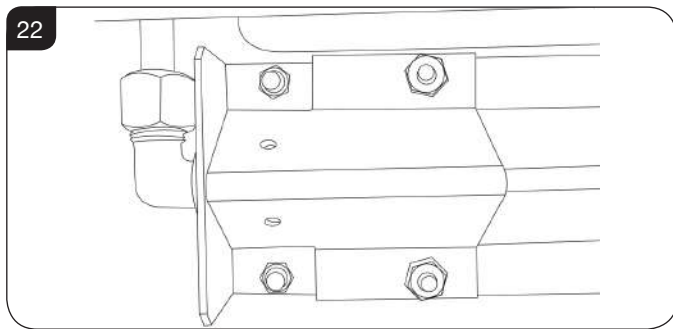

- 13.5 Reassemble in reverse order.

14. Changing Between Gas Types

A kit of parts is available for this - Contact your Dovre retailer for further information.

Always quote the Model number and Serial number when ordering any spare parts.

15. Control Upgrade

See Installation Instructions, Section 2.

Servicing Instructions - Replacing Parts

16. Spare Parts List - Dovre 425

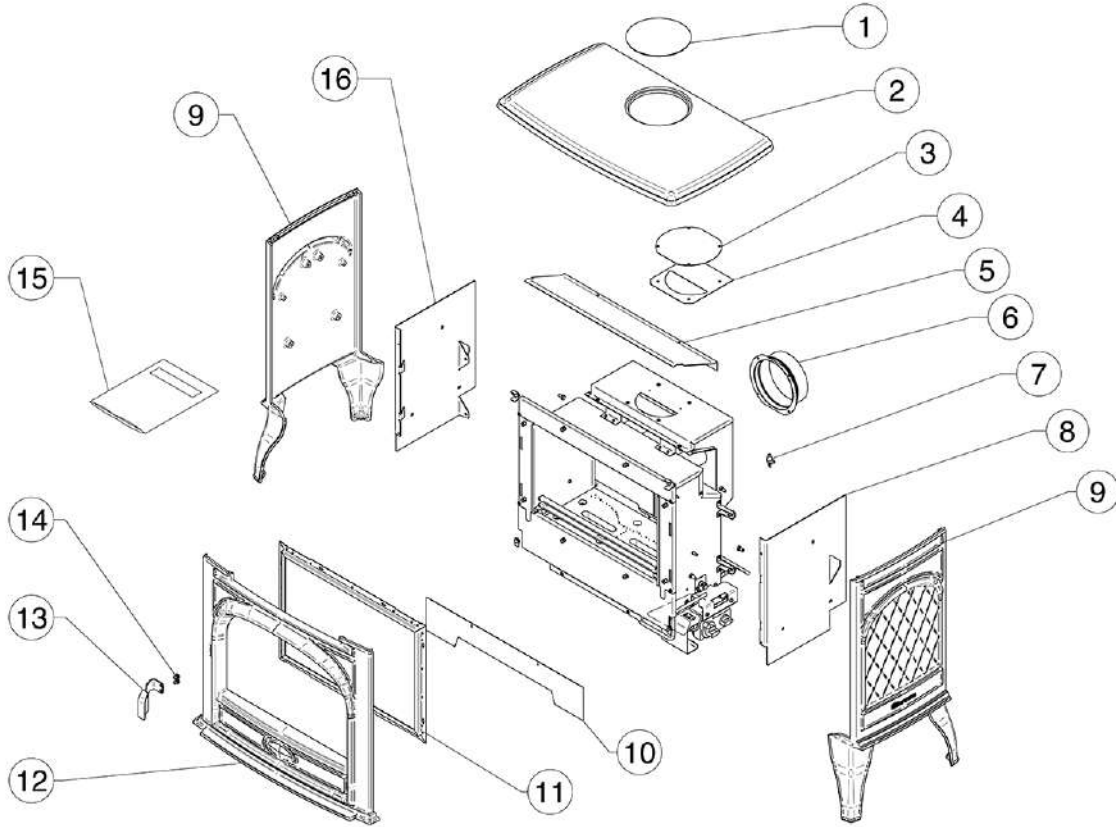

No.	Component	Part Code		Quantity
		Natural Gas	LPG	
1	Blanking Plate	DV-03.15348.002		1
2	Top Plate Casting	DV-03.69202.002		1
3	Blanking Plate	ME0608		1
4	Offset Plate	ME11021		1
5	Top Heat Shield	GZ1076		1
6	Spigot	MEC0033		1
7	Flue Sensor	EL0001		1
8	RH Firebox Support Bracket	GZ6059		1
9	LH & RH Side Casting	DV-03.79190.005		1
10	Skirt	GZ3608		1
11	Glass & Frame Assembly	GZ14965		1
12	Front Plate Casting	DV-03.24436.005		1
13	Door Handle	GZ6977		1
14	Screw	FA0063		2
15	Instruction Manual	PR2486		1
16	LH Firebox Support Bracket	GZ6058		1



Due to continual technical improvements please check online or with your Dovre retailer for the most up to date parts lists.
Only use Genuine Dovre spares when servicing your appliance.

Servicing Instructions - Replacing Parts

16. Spare Parts List - Dovre 425

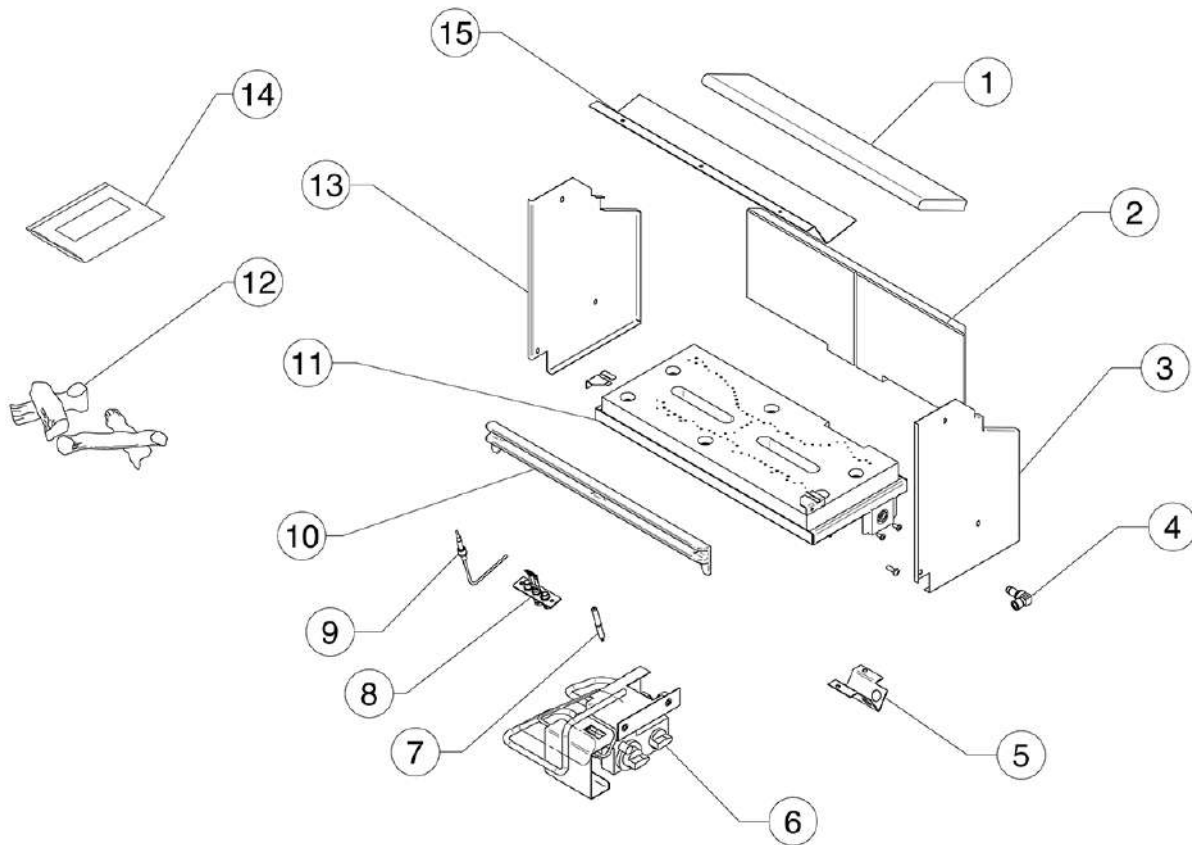

No.	Component	Part Code		Quantity
		Natural Gas	LPG	
1	Top Liner Panel	CE1312		1
2	Rear Liner Panel	CE1311		1
3	RH Reflective Panel	GZ11015		1
4	Injector	IN0076	IN0068	1
5	Aeration Cover	GZ10406	GZ11214	1
6	Engine Control Assembly	GZ14882		1
7	Electrode	PI0075		1
8	Pilot	PI0069	PI0070	1
9	Thermocouple	PI0074		1
10	Log Retainer	CA0765		1
11	Burner Assembly	GZ11001		1
12	Log Set	CE1304		1
13	LH Reflective Panel	GZ11014		1
14	Embaglow	GZ8471		1
15	Top Baffle	GZ11019		1



Due to continual technical improvements please check online or with your Dovre retailer for the most up to date parts lists.

Only use Genuine Dovre spares when servicing your appliance.

Servicing Instructions - Replacing Parts

16. Spare Parts List - Dovre 425

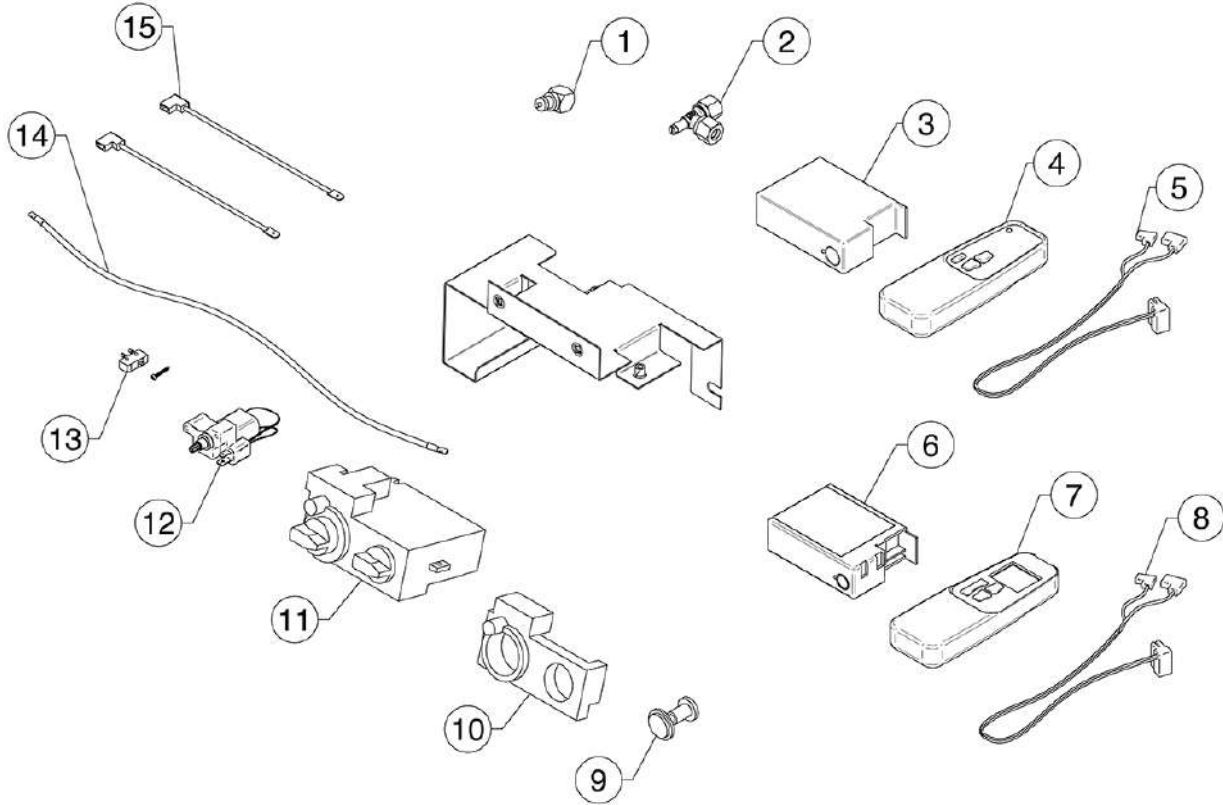

No.	Component	Part Code		Quantity
		Natural Gas	LPG	
1	Interrupter Block	GC0026		1
2	Pressure Test Elbow	IN0009		1
3	Standard Receiver	EL0235		1
4	Standard Handset	EL0239		1
5	Standard Receiver Cable	EL0237		1
6	Thermostatic Receiver	EL0236		1
7	Thermostatic Handset	EL0240		1
8	Thermostatic Receiver Cable	EL0238		1
9	Mag Unit	GC0166		1
10	Control Valve Cover	GC0087		1
11	Control Valve	GC0088K		1
12	Geared Motor	EL0234		1
13	Micro Switch and Screw	EL0241		1
14	Ignition Lead	GC0090		1
15	Flue Sensor Lead	EL0064		2



Due to continual technical improvements please check online or with your Dovre retailer for the most up to date parts lists.
Only use Genuine Dovre spares when servicing your appliance.



Service Records

1ST SERVICE

Date of Service
Next Service Due
Signed
Retailer's Stamp/GasSafe Registration Number

3RD SERVICE

Date of Service
Next Service Due
Signed
Retailer's Stamp/GasSafe Registration Number

5TH SERVICE

Date of Service
Next Service Due
Signed
Retailer's Stamp/GasSafe Registration Number

7TH SERVICE

Date of Service
Next Service Due
Signed
Retailer's Stamp/GasSafe Registration Number

9TH SERVICE

Date of Service
Next Service Due
Signed
Retailer's Stamp/GasSafe Registration Number

2ND SERVICE

Date of Service
Next Service Due
Signed
Retailer's Stamp/GasSafe Registration Number

4TH SERVICE

Date of Service
Next Service Due
Signed
Retailer's Stamp/GasSafe Registration Number

6TH SERVICE

Date of Service
Next Service Due
Signed
Retailer's Stamp/GasSafe Registration Number

8TH SERVICE

Date of Service
Next Due
Signed
Retailer's Stamp/GasSafe Registration Number

10TH SERVICE

Date of Service
Next Service Due
Signed
Retailer's Stamp/GasSafe Registration Number

Information Requirement - Gas Heaters

Information Requirement for Gaseous Fuel Local Space Heater

Model		Dovre 425 CF NG	Dovre 425 CF LPG
Fuel	Space Heating Emissions (NOx) - mg / kWh _{input} (GCV)	130	130
Heat Output	Nominal Heat Output - P_{nom}	4.6kW	4.8kW
	Minimum Heat Output (indicative) - P_{min}	1.8kW	2.3kW
Auxiliary Electricity Consumption	At Nominal Heat Output - $e_{l,max}$	N/A	N/A
	At Minimum Heat Output - $e_{l,min}$	N/A	N/A
	In Standby Mode - $e_{l,sb}$	N/A	N/A
Useful Efficiency (NCV)	Useful Efficiency at nominal heat output - $\eta_{th,nom}$	78%	78%
	Useful Efficiency at minimum heat output (indicative) - $\eta_{th,min}$	68%	68%
Permanent Pilot Flame Power requirement	Permanent Pilot Flame Power requirement (if applicable) - P_{pilot}	0.200kW	0.200kW

Type of heat output/room temperature control		
Two or more manual stages, no room temperature control	Yes	Yes

Other control options (multiple selections possible)		
Room temperature control, with presence detection	No	No
Room temperature control, with open window detection	No	No
With distance control option	No	No
With adaptive start control	No	No
With working time limitation	No	No
With black bulb sensor	No	No

Model with Manual Control

Energy Efficiency Index	66.8%	66.8%
Energy Efficiency Class	E	E

Model with upgradeable Thermostatic controls

Type of heat output/room temperature control		
Electronic room temperature control + day timer	Yes	Yes

Energy Efficiency Index	67.8%	67.8%
Energy Efficiency Class	E	E

Contact:	Dovre Ltd, Osprey Road, Sowton Industrial Estate, Exeter, EX2 7JG
-----------------	---



United Kingdom and Eire distributors for Dovre:

STOVAX

Stovax Limited, Falcon Road, Sowton Industrial Estate, Exeter, Devon, England, EX2 7LF.

Telephone: **(01392) 474011** Fax: **(01392) 219932**

E-mail: dovre@stovax.com Internet: www.dovre.co.uk

E & O E