

Di LUSO

Eco R4 Cube

Eco R5 Cube

Eco R6 Cube

Instructions for:
Installation/Operating/Maintenance/Serviceing

JINDLECU REV A 01/11/18

STOVE MODELS



ECO R4 ARCO
EDDLC04A



ECO R4 QUATTRO
EDDLC04Q



ECO R5 ARCO
EDDLC05A



ECO R5 QUATTRO
EDDLC05Q



ECO R6 ARCO
EDDLC06A



ECO R6 QUATTRO
EDDLC06Q



Welcome to the Hunter Stoves family and thank you for purchasing a Di Lusso stove. This stove was designed and built to be a high-performance heating appliance, and we hope it will bring you great enjoyment. The natural environment is important to us, so our stoves are manufactured to provide you with a clean and efficient burn that will keep you warm through cold winter nights.

CONTENTS INDEX:

STOVE MODELS.....	2
TECHINICAL SPECIFICATION.....	4
IMPORTANT INFORMATION.....	5/6
SAFETY.....	6
REMOVE INTERNAL COMPONENTS.....	7/8
INSTALLATION PROCEDURE	9/10
APPLIANCE DIMENSIONS.....	11
PRE INSTALLATION REQUIREMENTS.....	12
LEGAL REQUIREMENTS.....	13
CLEARANCES.....	13/16
COMMISSIONING AND HANDOVER.....	16/17
OPERATING INSTRUCTIONS.....	18-20
MAINTENANCE & SERVICING.....	20/21
TROUBLESHOOTING.....	22/23
OPTIONAL EXTRAS.....	23
SPARES.....	24-27
INSTALLATION & COMMISSIONING CHECK LIST.....	28
SERVICE RECORDS.....	29
FULL WARRANTY INFORMATION.....	30-31

Technical Specification

		Di LUSO CE		Eco R4 Cube (Both)	Eco R5 Cube (Both)	Eco R6 Cube (Both)
				A	A+	A
GENERAL	Energy Efficiency Class			A	A+	A
	Nominal Heat Output	Wood		4.9kW	6.3kW	6.2kW
	Energy Efficiency			106	107	102
	Efficiency	Wood		79%	81%	77%
	Mean CO (@13% O ₂)	Wood		0.09%	0.12%	0.09%
	Appliance Mass			105kg	156kg	146kg
	Recommended Fuels	Wood	Seasoned Wood (less than 20% moisture content)			
		Smokeless Fuel	Anthracite or a manufactured briquette smokeless fuel which is suitable for closed door appliances.			
	Log Length			250mm	350mm	330mm
FLUES	Mean Flue Gas Temperature	Wood		226°C	269 °C	299 °C
	Flue Gas Mass Flow	Wood		5.5 g/s	4.9 g/s	5.6 g/s
	Flue Outlet Size (Top or Rear Option)			127mm	127mm	127mm
VENTILATION	<ul style="list-style-type: none"> - Where leakage is greater than 5m³/hour/m² - Ventilation normally required = 550mm² per kW output over 5kW 		NONE	660mm²	715mm²	
	<ul style="list-style-type: none"> - Where leakage is less than or equal to 5m³/hour/m² - Ventilation normally required = 550mm² per kW output 		2695mm²	3410mm²	3465mm²	

For further information on ventilation please refer to Building Regulations Document J or your installer.

SMOKE CONTROL AREAS

This stove has been designed and assembled so that it may be used to burn wood logs in a Smoke Control Area. Find out if you are in a Smoke Control Area by contacting your Local Authority.

The Eco Di Lusso R4 Cube, R5 Cube and R6 Cube are only exempt for use in a smoke control area when fitted with a smoke control area kit R4 – JDLU0401 and R5/R6 – JDLU0501. Without the permanent stop in place the appliance is not an exempt appliance and so may leave the householder liable for a fine up to £1000.

IMPORTANT INFORMATION

**PLEASE READ THESE INSTRUCTIONS PRIOR TO INSTALLATION AND OPERATION.
KEEP THESE INSTRUCTIONS IN A SAFE PLACE FOR FUTURE REFERENCE AND
SERVICING.**

**THIS APPLIANCE WILL BECOME VERY HOT WHEN USED IN ACCORDANCE WITH
THESE INSTRUCTIONS, HUNTER STOVES RECOMMEND THAT AN APPROVED GUARD
IS USED TO PROTECT THE YOUNG, ELDERLY OR INFIRM FROM HARM.**

**THE INSTALLER COMMISSIONING SHEET CAN BE FOUND ON THE BACK COVER.
PLEASE ENSURE THAT IT IS COMPLETED PRIOR TO USE.**

General Guidance

It is important that your stove is correctly installed and operated as Hunter Stoves Group cannot accept responsibility for any fault arising through incorrect installation, use, maintenance or servicing.

These instructions cover the basic principles to ensure satisfactory installation of the stove, although detail may need slight modification to suit particular local site conditions.

The installation must comply with current Building Regulations, National and European Standards, Local Authority Byelaws and other specifications or regulations as they affect the installation of the appliance.

The Building Regulations requirements may also be met by adopting the relevant recommendations in the current issues of British Standards BS 8303 and BS EN 15287-1.

Only use approved fuels on this appliance. Information about this can be found on Page 20.

This is a Domestic Appliance and must only be used in accordance with these instructions. Do not place articles that are affected by high temperatures on, or near, this appliance. Do not place furniture or other items within 1 metre of the front of this appliance. See the note on material clearances on pages 13 - 16.

Fitting a stove in a room which also contains an extractor fan and/or cooker hood should be avoided where possible. If this is unavoidable, the suitability of the space for fitting this appliance must be decided at the discretion of a qualified installer, and a flue draught interference test must be performed.

Do not obstruct the ventilation required for the safe use of this appliance.

Competent Persons Scheme

Hunter Stoves Group recommend that this stove is installed by a member of an accredited competent persons scheme e.g. HETAS.

If the installer is not a member of a competent person's scheme, it is a legal requirement, in the UK, to notify your Local Building Control Officer in advance of any installation work starting.

Health and Safety Precautions

Special care must be taken when installing the stove such that the requirements of the Health and Safety at Work Act are met.

Handling

This appliance is very heavy. Adequate facilities must be available for loading, unloading and site handling.

Fire Cement

Some types of fire cement are caustic and should not be allowed to come into contact with the skin. In case of contact, wash immediately with plenty of water.

Asbestos

This stove contains no asbestos. If there is a possibility of disturbing any asbestos in the course of installation, then please seek specialist guidance and use appropriate protective equipment.

Metal Parts

When installing or servicing this stove, care should be taken to avoid the possibility of personal injury.

Modification

No unauthorised modification of this appliance should be carried out.

Safety

WARNING – This appliance will be hot when in operation and due care should be taken. The supplied operating tool or glove may be used to open the door and operate the air controls.

Aerosols

Do not use an aerosol spray on or near the stove when it is alight.

Fireguards

Always use a fireguard in the presence of children, the elderly or the infirm. The fireguard should be manufactured in accordance with BS8423 – Fireguards for use with solid fuel appliances.

Do Not Over-Fire

It is possible to fire the stove beyond its design capacity. This could damage the stove so watch for signs of over-firing. If any part of the stove starts to glow red, the stove is in an over-fire situation and the controls should be adjusted accordingly.

Never leave the stove unattended for long periods without first adjusting the controls to a safe setting. Careful air supply control should be exercised at all times.

Fume Emission

Properly installed, operated, this appliance will not emit fumes. Occasional fumes from de-ashing and refuelling may occur. Persistent fume emission must not be tolerated.

This appliance should not be operated with the door open.

If fume emission persists, then the following immediate action should be taken: -

- Open doors and windows to ventilate the room.
- Let the fire go out or eject and safely dispose of fuel from the appliance.
- Check for flue/chimney blockage and clean if required.
- Do not attempt to re-light the fire until the cause of the fume emission has been identified and corrected.

If necessary, seek expert advice.

Adverse Weather

In a small number of installations, occasional local weather conditions (e.g. wind from a particular direction) may cause downdraught in the flue and cause the stove to emit fumes. In these circumstances, the stove should not be used. A professional flue installer will be able to advise on solutions to this problem (e.g. anti-downdraught cowl).

Carbon Monoxide Detector

Hunter Stoves recommend a Carbon Monoxide Detector that conforms to the latest issue of BS EN 50292 is placed in the same room as the appliance. The installation of such an alarm is not considered as a substitute for regular maintenance or servicing of the appliance and Flue system.

IN THE EVENT OF A CHIMNEY FIRE:

- Raise the alarm
- Call the Fire Brigade
- Close appliance air controls
- Move furniture, ornaments etc. away
- Place a fireguard in front of stove
- Check the chimney breast for signs of excessive heat.

If the wall is becoming excessively hot, move furniture away.

Ensure the Fire Brigade can gain access to your roof space in order to check for fire spread.

Removing Internal Components

All internal components must be removed prior to fitting the stove. This will make handling the stove easier; allow access to fixings and the flue outlet; as well as protect the internal components from damage during the installation process.

1. To open the stove door, pull on the door lever to release it from the magnet.

N.B When closing the door keep the door handle out to the right until the door is closed.

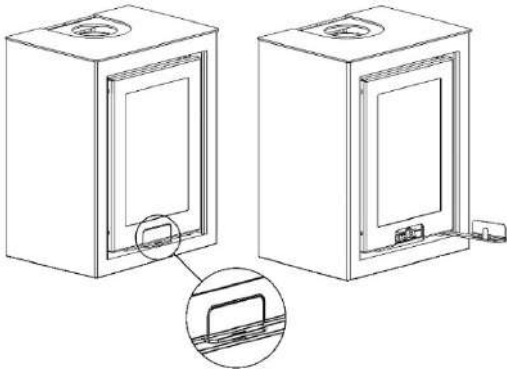

N.B from this point forward, the door has been hidden for illustrative purposes.

2. Remove the log retainer by lifting it clear of the two support pins.

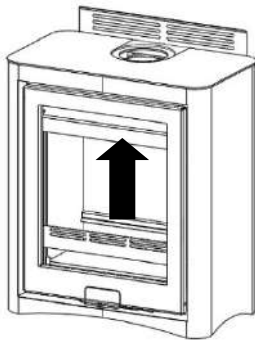

3. Remove the baffle brick (Eco R4/Eco R5 by lifting it up, sliding it to the right and then lowering the left-hand edge into the firebox. For the Eco R6 slide both baffle plates to the centre with left hand baffle on top of right-hand baffle and lift out of stove together.

Eco R4/R5

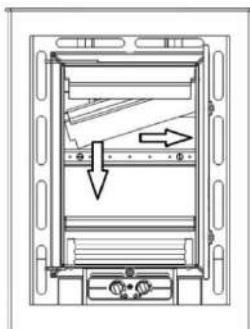

Eco R6

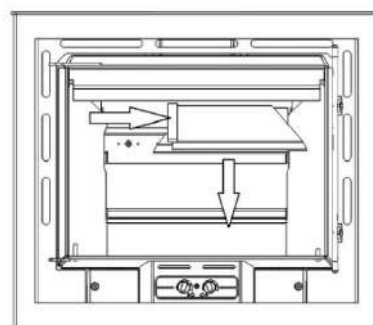

4. Remove the two side bricks by lifting them up to release them from the slots in the base brick. Swing the bricks into the centre and remove them from the stove.

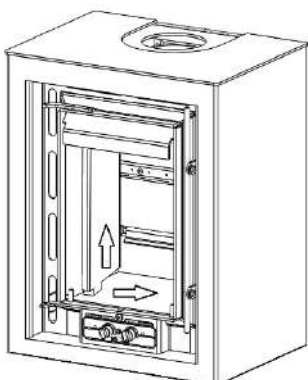

5. Remove the three rear brick sections (Eco R4) and two rear bricks (Eco R5/Eco R6) noting their positions and orientation.

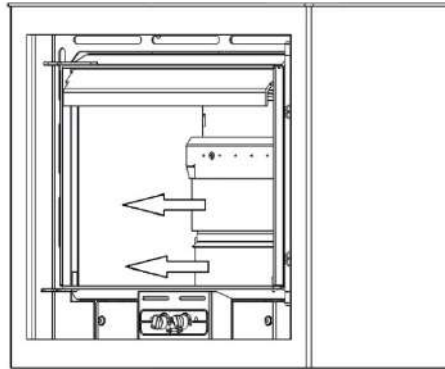
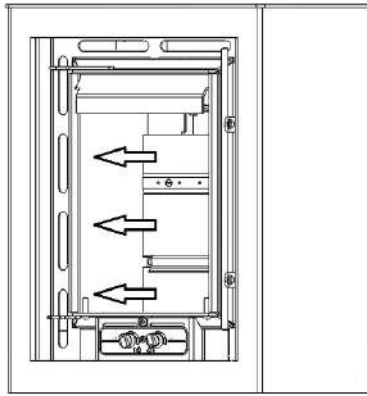

6. Lift up and remove the base brick(s)

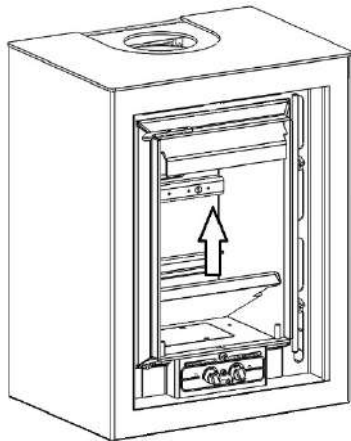

7. Remove the Air Valve Cassette by removing the socket screws holding it in place, turning both air controls to the fully open position (clockwise) and then gently pulling on the fascia to slide the cassette out from under the firebox. **N.B DO NOT Remove the Air Valve Cassette with the controls in the closed position as this will damage the valve gaskets.**

Eco R4 and
Eco R5

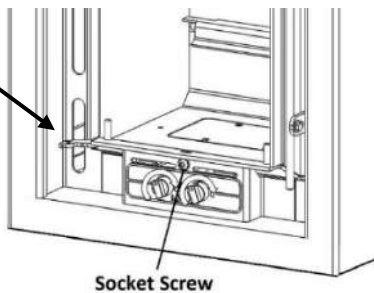

Eco R6

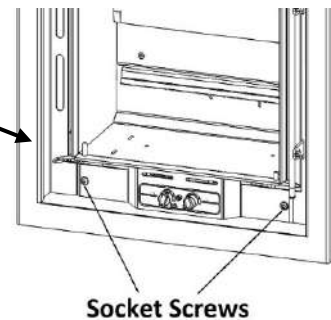

ALL

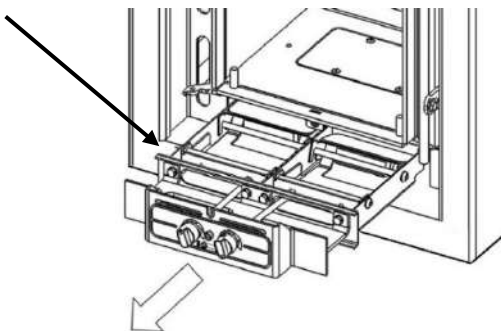

Installation Procedure

Note: If installing the direct air kit, follow the instructions supplied with the kit before.

1. If using installation method B, fit the flue heat shield to the back of the stove using the supplied screws.



2. Offer the stove into position and adjust the levelling feet as required.

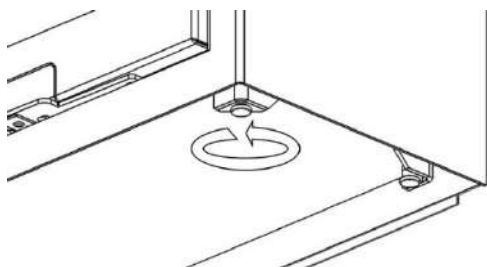

3. Open the stove door and remove the top plate fixing screws.

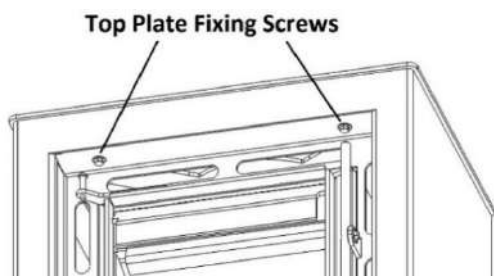

4. Lift the outer top plate off the stove.

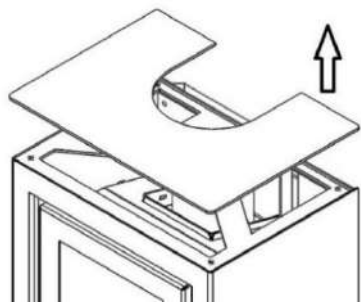

5. Insert the flue adaptor/pipe into the flue collar so that either the adaptor rests on the wrapper top or the pipe rests on the support blocks inside the flue collar.

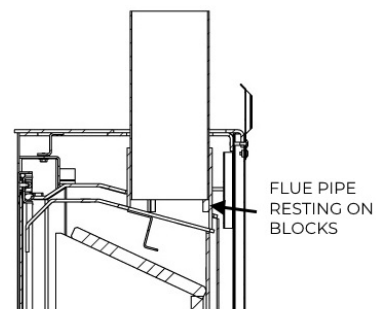
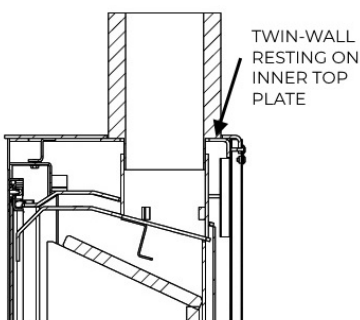
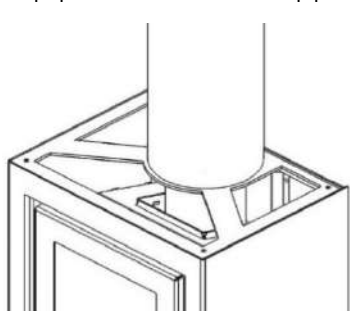

6. Seal the flue adaptor/pipe to the flue collar using fire cement.

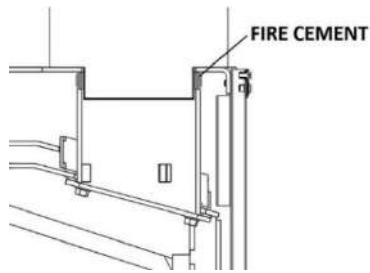

7. Refit the outer top plate and fixing screws to complete the installation.

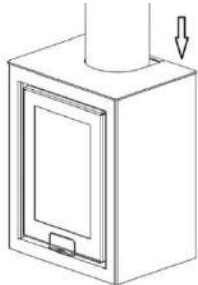

Eco R6 Only

1. Unpack the baffle and identify the two halves.

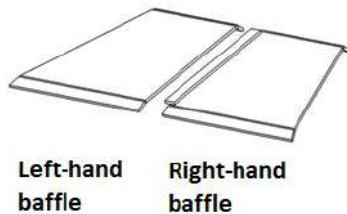

2. Stack the two baffle halves with the right-hand baffle sat on top of the left-hand baffle as shown.



3. Lift the two baffles up together inside the firebox to the right-hand side of the baffle support bracket, slide the baffles to the left and rest them on the support bracket at the front of the stove and the compound tertiary cover.

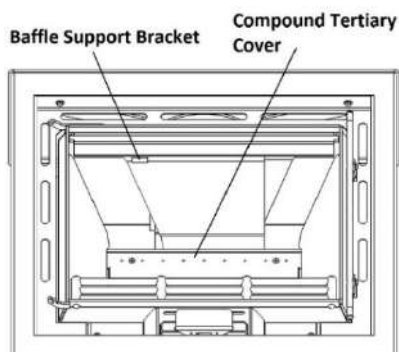

4. Slide the left-hand baffle to the left and the right-hand baffle to the right, push them towards the rear of the firebox so that the baffles drop down and sit tightly together as shown.

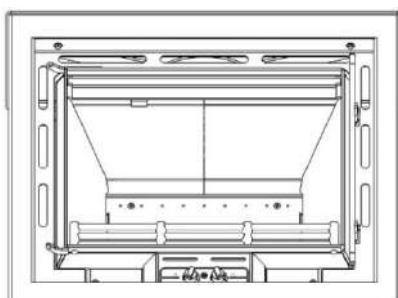

Appliance Dimensions

ECO R4 CUBE

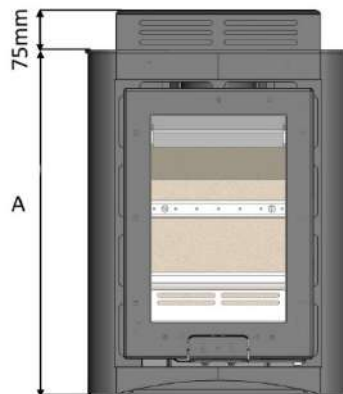
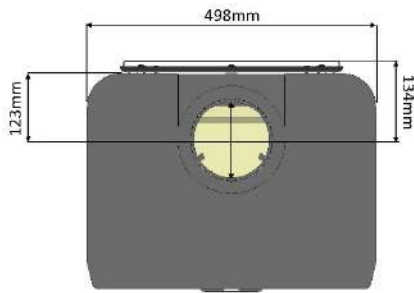

STOVE MODEL	DIMENSION 'A'
4-SIDED	645
ARCO	645

ECO R5 CUBE

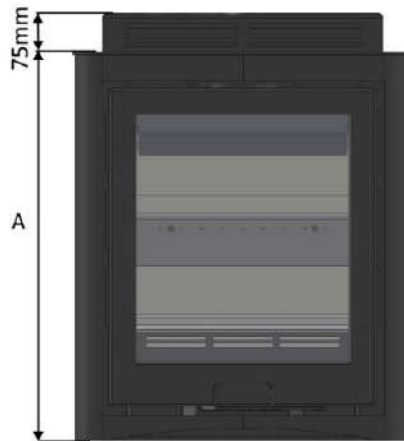
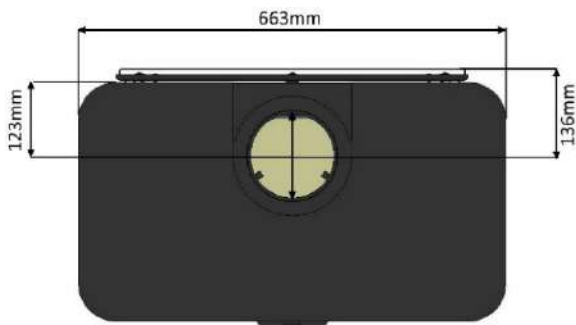

STOVE MODEL	DIMENSION 'A'
ARCO/QUATTRO	755

ECO R6 CUBE

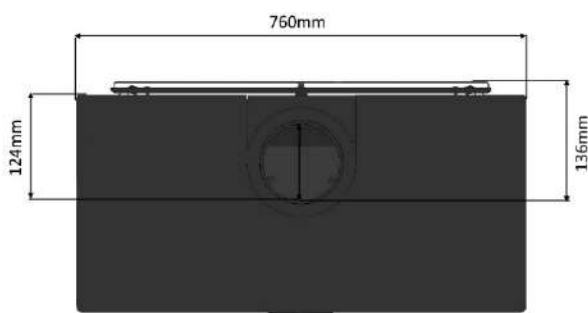

STOVE MODEL	DIMENSION 'A'
ARCO/QUATTRO	645

Pre-Installation Requirements

PLEASE CHECK THE FOLLOWING:

Any existing chimney/flue system must be confirmed as suitable for this appliance as defined in Building Regulations Document J. It must be swept and inspected, by a competent person (see notes), to confirm that is structurally sound and free from cracks and obstructions.

The diameter of the Flue should not be less than 127mm and not more than 200mm. Do not connect to systems that have large voids or spaces. If any of these requirements are not met, the chimney should be lined by a suitable method.

If the chimney is suspected of previously serving an open fire it must be swept again, within a month of regular use, to clear any soot that may have been dislodged due to the variation in combustion levels and higher flue gas temperature levels. The chimney/flue system exit must comply with Building Regulations Document J. The minimum height and should terminate in accordance with Table 1.

Connection to the Chimney

An existing fireplace opening can be bricked up or sealed with a register plate. A short length of flue pipe of minimum 127mm internal diameter may then be used to connect the stove to the chimney. This flue pipe should be made of 316 grade stainless steel or vitreous enamelled steel, nominal thickness 1.2mm. The length of any horizontal run of flue pipe must not exceed 127mm. It is essential that all connections between the stove and chimney-flue are sealed and made airtight.

Make provision to access the chimney/flue system for cleaning and the removal of debris. If there is no existing chimney then either a prefabricated block chimney in accordance with Building Regulations Approved Document J, or a twin-walled insulated stainless-steel flue to BS4543 can be used. These chimneys must be fitted in accordance with the manufacturer's instructions and Building Regulations. New masonry and flue block chimneys must meet the requirements of Building Regulations Document J. Any connecting flue pipe systems must also meet these regulations.

Please check the suitability of the fireplace and/or surround for use with this appliance before installing it. If you have any doubts about the suitability of your chimney, consult your local Dealer/Stockist or Installation Engineer. Both the chimney and flue pipe must be accessible for cleaning and if ANY part of the chimney cannot be reached through the stove (with baffle removed), a soot door must be fitted in a suitable position.

Flue Outlet Positions (Document J):

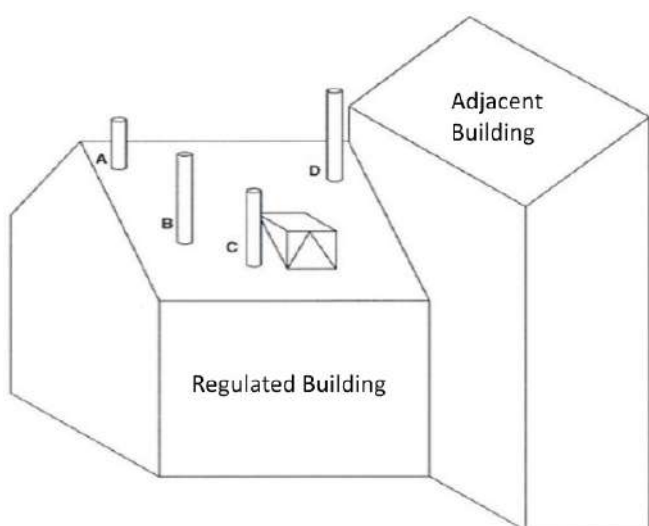

	Position on Roof	Clearances to flue exit
A	At or within 600mm of the ridge	At least 600mm above the ridge
B	Elsewhere on a roof (Pitched or Flat)	At least 2.3 M horizontally from the nearest point on the weather surface and: a) At least 1.0 M above the highest point of intersection between the chimney and weather surface; or b) at least as high as the ridge
C	Below (on a pitched roof) or within 2.3 M horizontally to an opening window or dormer	At least 1.0 M above the top of the opening
D	Within 2.3 M of an adjoining or adjacent building, whether or not beyond the boundary	At least 600mm above any part of the adjacent building within 2.3 M

Table 1.

A full copy of Document J can be found here:

http://www.planningportal.gov.uk/uploads/br/BR_PDF_ADJ_2010.pdf

Legal Requirements

Hunter Stoves Group requests that before installation and/or use of this appliance that you read these instructions carefully to ensure that all the relevant requirements are fully understood.

These instructions cover the basic principles to ensure satisfactory installation of the stove, although detail may need slight modification to suit particular local site conditions. In all cases the installation must comply with current Building Regulations, Local Authority Byelaws, European and National Standards and other specifications or regulations as they affect the installation of the stove.

It should be noted that the Building Regulations requirements may be met by adopting the relevant recommendations given in British Standards BS 8303, BS 6461 and BS 7566 as an alternative means to achieve an equivalent level of performance to that obtained following the guidance given in Approved Document J.

Your local Building Control Officer can advise you regarding the interpretation of the Regulations should there be any questions.

This appliance must be installed by a Registered Installer (see Competent Persons Scheme) or approved by your local Building Control Officer.

All works undertaken must be carried out with due care and attention to meet the requirements of the Health & Safety code of practice and any other legislation that may have been introduced since the publication of these instructions.

Competent Persons Scheme

Members of the following schemes may self-certify the installation of this stove. If the installer is not a member of one of these schemes, your local Building Control Department must approve the installation.

Scheme	Web address	Telephone
APHC (Association of Plumbing and Heating Contractors (Certification) Limited)	www.aphc.co.uk	02476 470 626
Building Engineering Services Competence Accreditation (BESCA Limited)	www.hvca.org.uk / www.besca.org.uk	0800 652 5533
HETAS Ltd (Heating Equipment Testing and Approval Scheme)	www.hetas.co.uk	01462 634721
NAPIT Registration Ltd	www.napit.org.uk	0870 444 1392
NICEIC Group Ltd	www.niceic.org.uk	0800 013 0900

Air Supply

The room or space containing this appliance does not need a permanent, unobstructed air opening – Eco R4 only. The Eco R5 needs a permanent air opening of 615mm² and the Eco R6 – 715mm².

If a draught stabiliser is fitted, the air opening should be at least 1470mm² - Eco R4, 2605mm² - Eco R5 and 1800mm² - Eco R6.

Due consideration should be given to air requirements for any other appliance in the same room or space. Any air opening must be kept clear from blockage or obstruction.

Hearth/ Material Clearances

Hearth constructions must comply with the current building regulations.

Your stove must be installed on a floor with adequate load-bearing capacity, otherwise suitable measures should be taken. If the existing construction does not meet this pre-requisite, suitable measures (e.g. load distributing plate).

Care should be taken to level the stove using the adjusting screws in the feet.

Material Clearances

Minimum Distances to Combustible Material	Eco R4 Cube	Eco R5 Cube	Eco R6 Cube
Behind the stove (if using twin-wall flue pipe)	50mm	50mm	50mm
At the side of the stove (Side wall protruding in front of stove)	200mm	250mm	150mm
In front of the stove	800mm	1100mm	1200mm

EN13240

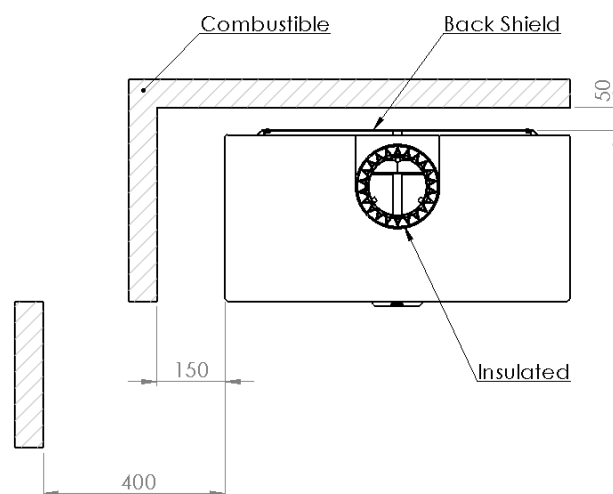
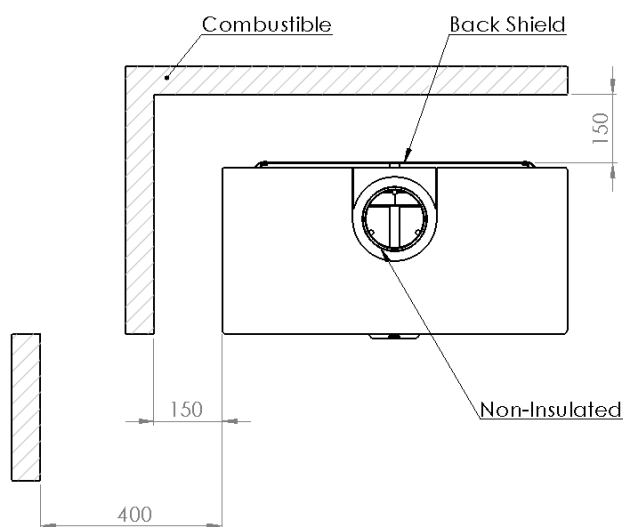

NS FIRE WALL
FOR NORWAY ONLY (BELOW)

NS FIRE WALL

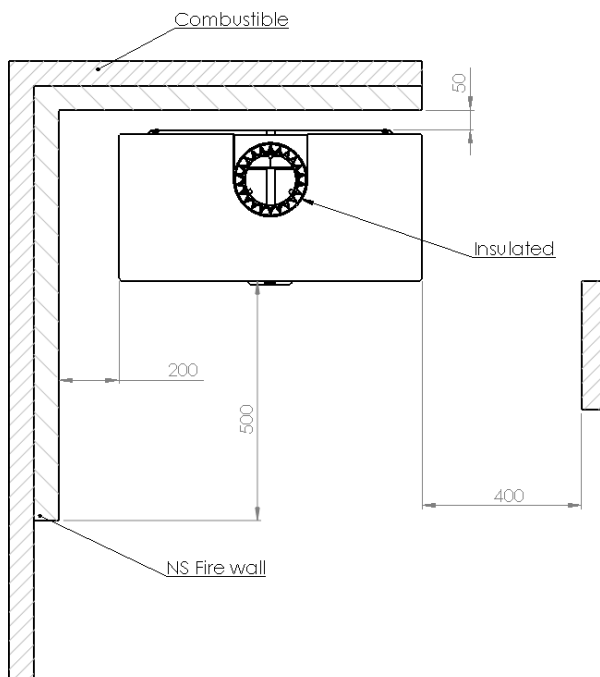
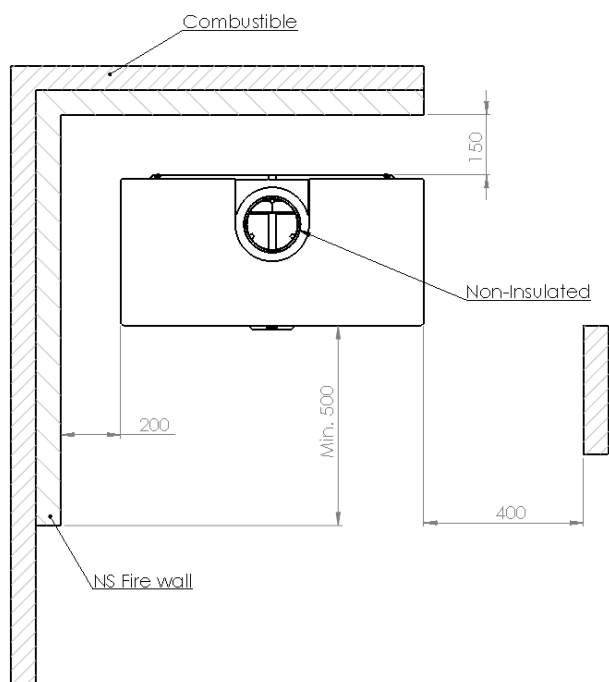

Note: combustible material refers to any material that will degrade when subjected to heat e.g. plaster.
No combustible material must be stored underneath the stove.

Note: To achieve the specified distances to combustible materials, twin-wall insulated flue pipe must be used, starting no higher than 75mm above the stove.

The stove can be installed by two methods;

Method A:

Use a 5" twin-wall flue pipe adaptor with a flat bottom face and a spigot length of between 30mm and 110mm. The supplied flue heat shield is not required when using this method because the adaptor is flush with the top plate.

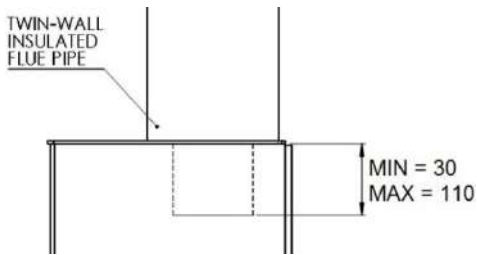

Method B:

Use an adaptor that has a spigot or conjoining pipe length of between 110mm and 190mm. This ensures that the twin-wall pipe does not start any higher than 75mm above the stove. The flue heat shield must be used with this method.

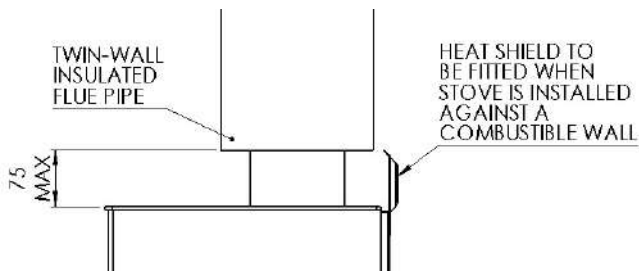

Fireplace Recess All

Plan view:

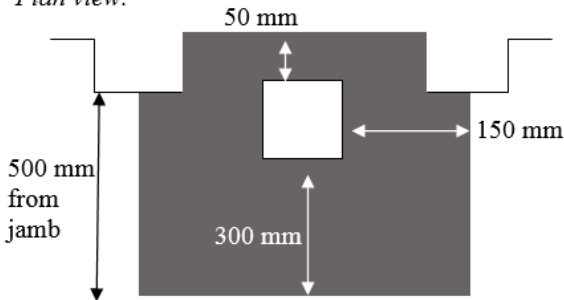

Side view:

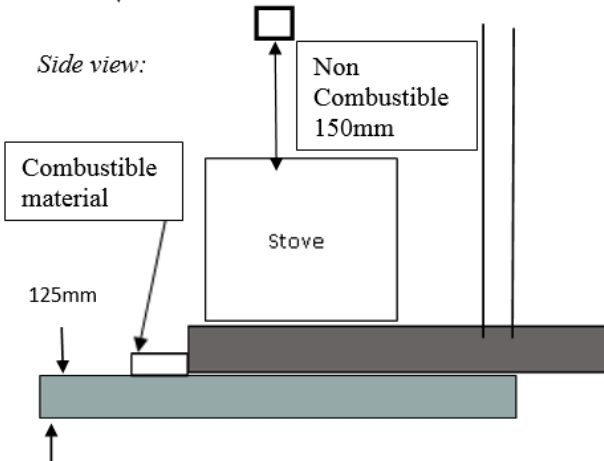

The stove can be recessed in a suitable sized fireplace but a permanent free air gap of at least 150mm on top and 50mm at the sides (although we recommend 150mm for the sides and 50mm at the back of the stove to obtain maximum heat output and for access to the rear of the stove.)

The hearth should extend at least 300 mm from the front of the stove. The stove should stand wholly above a solid, non-combustible hearth, at least 125 mm thick (this may include the thickness of a solid floor and a non-combustible decorative hearth).

Free-Standing All

Plan view:

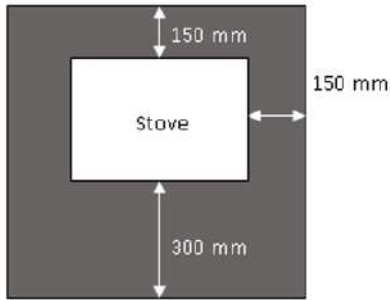

If the stove is not to stand in a recess, it may stand wholly above a hearth made of non-combustible board / sheet material or tiles, at least 10mm thick.

The hearth should extend at least 150 mm from the sides and rear of the stove, and at least 300 mm from the front of the stove.

All walls shown in the above diagrams are non-combustible unless otherwise indicated. All non-combustible walls closer than 300mm to the stove should be at least 75mm thick.

Side view:

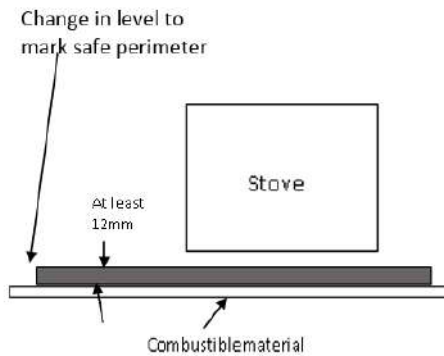

Commissioning & Handover

Appliance Check

Please check that all components are correctly assembled and working correctly.

Ensure the Air Controls are working correctly.

Hunter Stoves Group recommend that you carry out a smoke draw test to check the soundness of the chimney/flue system and seals:

Place a Smoke Pellet in the centre of the Grate, ensure that all of the Air Controls are fully open and close the Door.

The smoke should now be drawn up the chimney and you should be able to see it exit from the chimney/flue terminal.

We recommend that you do this test with all of the windows and doors, to the room where the appliance is fitted, closed.

If there any adjoining room(s) that have an Extractor Fan fitted, open the adjoining door to ensure that the chimney/flue system is not compromised when the fan is operating. If there is a ceiling fan fitted in the room, please operate it and ensure that it does not affect the operation of the chimney/flue system.

If any of these tests fail, please re-check the suitability of the chimney/flue system together with the ventilation.

A small fire can now be lit and allow the appliance to heat up slowly ensuring that no products of combustion enter into the room.

Carry out a spillage test using a smoke match around the door opening.

If there is excessive spillage, please allow the appliance to cool and then re-check the chimney/flue system and ventilation.

Do not run the stove at full output for at least 24 hours.

On completion of the commissioning:

Upon completion, allow a suitable period of time for any fire cement and mortar to dry out.

Please instruct the user on the safe operation of this appliance, how the controls work and basic maintenance requirements.

Ensure that the operating instructions and appliance tools are left with the customer and the check lists have been filled out correctly.

Please advise the customer on the correct use of the appliance with the fuels likely to be used on the stove and warn them to use only the recommended fuels for the stove.

Advise the user on what to do should smoke or fumes be emitted from the stove.

The user should be warned to use a fireguard to BS 8423 in the presence of children, aged and/or infirm persons.

Hunter Stoves Group also recommend that a CO alarm is fitted into the room where the appliance is located.

Flue Draught

If the draught exceeds the recommended maximum, a draught stabiliser must be fitted so that the rate of burning can be controlled and to prevent over firing.

If the reading is less than the recommended minimum, then the performance of the appliance will be compromised. The flue draught should be checked under fire at high output with windows and doors closed. To take the reading remove one of the coach bolts in the flue collar and put the probe in the hole.

Minimum Draught – 1.2mm Water Gauge

Maximum Draught – 2.5mm Water Gauge

THE CLEAN AIR ACT 1993 AND SMOKE CONTROL AREAS

Under the Clean Air Act local authorities may declare the whole or part of the district of the authority to be a smoke control area. It is an offence to emit smoke from a chimney of a building, from a furnace or from any fixed boiler if located in a designated smoke control area. It is also an offence to acquire an "unauthorised fuel" for use within a smoke control area unless it is used in an "exempt" appliance ("exempted" from the controls which generally apply in the smoke control area).

In England appliances are exempted by publication on a list by the Secretary of State in accordance with changes made to sections 20 and 21 of the Clean Air Act 1993 by section 15 of the Deregulation Act 2015. Similarly, in Scotland appliances are exempted by publication on a list by Scottish Ministers under section 50 of the Regulatory Reform (Scotland) Act 2014.

In Northern Ireland appliances are exempted by publication on a list by the Department of Agriculture, Environment and Rural Affairs under Section 16 of the Environmental Better Regulation Act (Northern Ireland) 2016.

In Wales appliances are exempted by regulations made by Welsh Ministers.

Further information on the requirements of the Clean Air Act can be found here: <https://www.gov.uk/smoke-control-area-rules>

Your local authority is responsible for implementing the Clean Air Act 1993 including designation and supervision of smoke control areas and you can contact them for details of Clean Air Act requirements.

The Di Lusso R4 Cube, R5 Cube and R6 Cube have been recommended as suitable for use in smoke control areas when burning wood logs.

Refuelling on to a low fire bed

If there is insufficient burning material in the firebed to light a new fuel charge, excessive smoke emission can occur. Refuelling must be carried out onto a sufficient quantity of glowing embers and ash that the new fuel charge will ignite in a reasonable period. If there are too few embers in the fire bed, add suitable kindling to prevent excessive smoke.

Fuel overloading

The maximum amount of fuel specified in this manual should not be exceeded, overloading can cause excess smoke.

Operation with door left open

Operation with the door open can cause excess smoke. The appliance must not be operated with the appliance door left open except as directed in the instructions.

Dampers left open

Operation with the air controls or appliance dampers open can cause excess smoke. The appliance must not be operated with air controls, appliance dampers or door left open except as directed in the instructions.

Operating Instructions

Read the 'General Guidance' Section at the start of these instructions before operating your stove for the first time.

Allow sufficient clearance between the stove and pictures, plasma screen televisions or ornaments etc., as these could be damaged and could potentially create a fire hazard (For more information read the 'Material Clearance' section of these installation instructions).

WARNING – This appliance will be hot when in operation and due care should be taken. The supplied operating tool or gloves may be used to open the door and operate the air controls.

Please Note

Your Building Insurance Company may require you to inform them of this new installation and that the work has been carried out correctly. Please check your policy to ensure that it is still valid when this installation is complete.

Using The Appliance For The First Time

We recommend that the appliance is left for 24 hours after installation to allow the fire cement, fixing glues, etc. to cure.

With the painted finish, we recommend that you have two or three small fires before you operate your stove to its maximum heat output. This is to allow the paint to cure in steadily and to give a long service life of the paint finish.

During this curing in process you may notice an unpleasant smell. It is non-toxic, but for your comfort we would suggest that during this period you leave all doors and windows open.

Aerosols

Do not use an aerosol spray on or near the stove when it is alight.

Air Controls

This stove has been designed to burn far more efficiently than a traditional stove, with the obvious notable feature of clean glass.

However, for this product to work properly it must be used correctly. It is essential that the stove has an adequate air supply for combustion and ventilation.

To access the air controls, pull on the door handle to release it from the magnet and swing it to the right. If the stove is hot, use the tool provided. Insert the end of the tool into the slot in the handle.

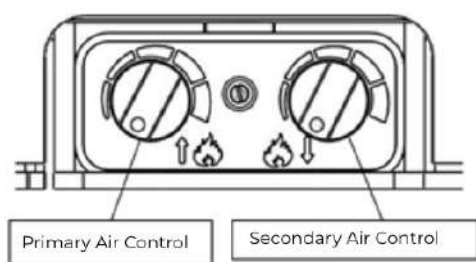

Primary Air Control

Regulates air flow directly into the firebed. This is used when lighting from cold or when reviving a fire that has nearly burnt out. Turn clockwise to open and anti-clockwise to close. **IMPORTANT – The Primary air control must be closed once the fire is established.**

Secondary Air Control

Regulates the flow of air downwards into the combustion chamber via the airwash (airflow over the inside of the glass) and the tertiary air inlet (air inlet holes in the back of the firebox). Turn clockwise to open and anti-clockwise to close. **This control is used to regulate the burn rate and therefore heat output of the stove.**

Warning! – This Appliance will be hot when in operation and due care should be taken.

We advise that suitable gloves are used when operating the air control, and when opening the door.

Tertiary Air

Tertiary Air enters the firebox through the series of holes in the rear wall. This air supply helps to reduce emissions into the atmosphere. The tertiary air supply is fixed and cannot be adjusted.

Lighting the Stove

Open both air controls fully and light one or two firelighters placed centrally on the bottom grate, allowing the flames to become established before placing several pieces of small dry kindling in a criss-cross fashion above the firelighters, taking care not to smother the fire.

Close the stove door. Once the kindling is well alight open the door and build the fire by gradually adding slightly larger pieces of wood, closing the door afterwards.

Once the fire is established close the Primary Air Control (anti-clockwise) and add more fuel as necessary. The Secondary Air control can now be used to regulate the burn rate of the stove.

Should the fire fail to light correctly open the door and use a poker to spread the fuel across the grate. Close the door and allow the fuel and stove to cool before attempting to relight the fire.

N.B. Leaving the air controls in the closed position, adding too much fuel or using wood that is wet or too large will prevent the fire from establishing correctly and may result in smoke emission from the stove.

When the stove is up to operating temperature the operating tool or gloves should be used to operate the air controls.

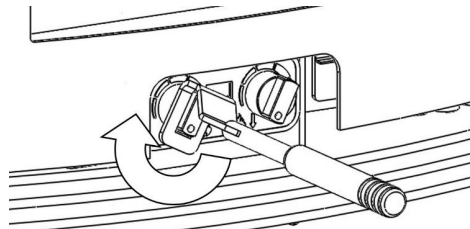

Recommended Settings

Once the fire is established the Primary Air Control should be fully closed and the Secondary Air Control turned to a setting of approximately

Eco R4 - 50 -60% open

Eco R5 – 30-40% open

Eco R6 – Primary 20% and Secondary 60-70% open

This setting should allow the nominal output and efficiency to be achieved.

Avoid running the stove on very low air settings as this could result in a reduction in efficiency and increase emissions into the atmosphere.

Refuelling

Refuelling must be carried out with a sufficient quantity of glowing embers and ash, so that the new fuel charge will ignite quickly. If there are too few embers, add some kindling to prevent excessive fuel. The air controls should not need adjusting while refuelling.

Do not add firewood above the level of the tertiary air inlet at the back of the stove. Exceeding this amount can result in the production of excessive smoke.

R5 - It is recommended that 3 logs are used with an approximate length of 190mm and a combined weight of 1.6kw with the bark removed.

R6 – It is recommended that 2 logs are used with an approximate length of 240mm and a combined weight of 1.6kg with the bark removed.

De-Ashing

From time to time it will be necessary to remove excess ash from the firebox. This can be done by lifting up the log retainer to release it from its supports and removing the ash with a small shovel.

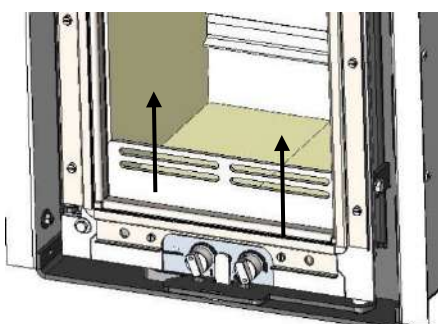

Recommended Fuels

Hunter Stoves Group recommend that only wood logs with a moisture content of less than 20% and anthracite or a manufactured briquette smokeless fuel which is suitable for closed door appliances are used on this appliance (with Multifuel Kit only). Burning wet or unseasoned wood will create excess smoke emissions, tar deposits in the stove and chimney and will not produce a satisfactory heat output.

Only authorised fuels may be used in UK smoke control areas.

A list of authorised fuels can be found at <http://uksmokecontrolareas.co.uk/fuels.php>

WARNING - DO NOT BURN BITUMINOUS COAL, PETRO-COKE, OTHER PETROLEUM BASED FUELS OR TREATED WOOD SUCH AS PALLETS AS THIS WILL INVALIDATE THE PRODUCT WARRANTY. HOUSEHOLD WASTE MUST NOT BE BURNT ON THIS APPLIANCE.

A list of approved fuels can be found at: -

HETAS Ltd – Telephone 01242 673257 – http://hetas.co.uk/public/hetas_guide.html

Solid Fuel Association – Telephone 0800 600 000 – www.solidfuel.co.uk

Maintenance And Servicing

WARNING!

NO unauthorised modification of this appliance should be carried out.

IMPORTANT!

In order to ensure continued compliance with current Building Regulations and Local Authority Byelaws, this appliance requires regular maintenance by a competent person. N.B. Refer to the 'Removing Internal Components' section of the installation instructions for details on how to remove each component.

Periods Of Prolonged Non-Use

If the stove is to be left unused for a prolonged period, then it should be given a thorough clean to remove ash and unburned fuel residues. To enable a good flow of air through the appliance to reduce condensation and subsequent damage, leave the air controls fully open. If the appliance has been unused for a long period, such as during the spring and summer months, a competent person should check the chimney for potential obstructions before lighting the stove ***i.e. get the chimney swept before the start of the heating season?***

Baffle

This should be removed and cleaned at least once a month to prevent any build-up of soot or fly ash that could lead to blocked flue ways and dangerous fume emission. If the baffle is removed the chimney/flue way can be swept through the appliance.

Air Valve Cassette

This should be removed and cleaned monthly to remove any ash that may be in the controls. ***N.B. Make sure that controls are in the maximum position (fully clockwise) before removing the Air Valve Cassette.***

Stove Body

Painted Finish - The stove is finished with a heat resistant paint and this can be cleaned with a dry soft brush or dry microfibre cloth. Do not clean whilst the stove is hot. **At no point should any water or other cleaning products be used on the stove.** The finish can be renovated with Hunter Stoves paint.

Glass Panel

Clean the glass panel when cool with a propriety glass cleaner. Highly abrasive substances should be avoided as these can scratch the glass and make subsequent cleaning more difficult. Wet logs on heated glass, a badly aimed poker or heavy slamming of the doors could crack the glass panels. The glass will not fracture from heat. Please do not overtighten the glass spacer clip.

Firebricks

In normal use, these can last for many years. It is possible however, to crack them if logs are continually jammed against them or if they are frequently struck with a poker. Check periodically for seriously cracked bricks, which can be replaced with new, available from your dealer or our spares website www.hunterstoves.co.uk.

Door Catch

Over time the rope seal in the door will become compressed. It may therefore be necessary to adjust the door catch to maintain the door seal. To adjust the catch, slacken the two set screws on the catch bar and adjust the position of the catch bar as necessary.

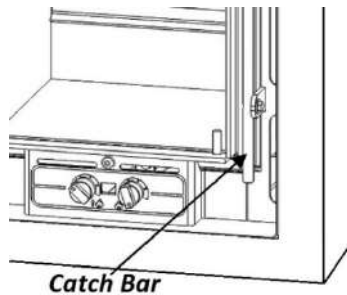

Air Valves

Over time the sealing face of the air valves may wear. This will reduce the effectiveness of the controls. To replace a worn valve, remove the air valve cassette, lift off the worn valve and replace with new.

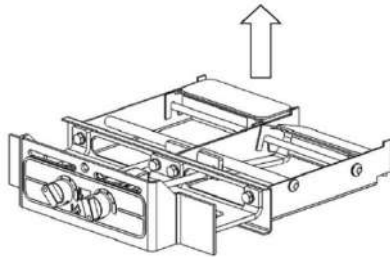

Annual Service

Hunter Stoves Group recommend that this appliance is serviced annually, preferably prior to the start of the heating season, thus avoiding any delay in receiving replacement components, should you need them. If you feel unable to undertake this task, Hunter Stoves recommend that you contact the installation engineer for advice.

Chimney and Flue ways

It is important that the chimney, flue ways and any connecting flue pipe are swept regularly. This means at least once a year for smokeless fuels and at least twice a year for wood and other fuels. The baffle will need to be removed from its supports in order to sweep the chimney (see assembly instructions). Only wire-centred sweeps' brushes fitted with a guide wheel should be used. If it is not possible to sweep all parts of the chimney through the appliance, ensure there is adequate access to cleaning doors. If the stove is fitted in place of an open fire, then the chimney should be swept one month after installation to clear any soot falls which may have occurred due to the difference in combustion between the stove and the open fire.

Remove all the internal components:

Clean them with a soft brush and inspect them for damage.

Sweep the chimney/flue system if necessary.

Clean down the internal surfaces of the appliance using a scraper or wire brush.

Inspect these surfaces for damage/corrosion. If corrosion or damage is found, we advise that you consult with your installer about rectification/repair.

Brush out or vacuum the inside of the appliance and re-fit the internal components.

Inspect the Glass and clean with a non-abrasive cleaner if required

Painted Finish

Brush down the outer surface with a dry soft brush or dry microfiber cloth only and touch up the paint if necessary. Burn the appliance at a low rate, after maintenance, to allow any new seals, paint or glue cure properly. The appliance may emit unpleasant odours during this process, please ensure the room is well ventilated.

The paint can be ordered through our website www.hunterstoves.co.uk.

TROUBLESHOOTING

	ISSUE	CAUSE	RESOLUTION
OPERATION	Problem starting the fire and keeping it burning	Low flue draught	Speak to your installer
		Wood with moisture content over 20%	Ensure use of dry seasoned wood with less than 20% moisture content
	Unable to control fire	High flue draught	Speak to your installer
	Short burn time	Wood with moisture content over 20%. Insufficient amount of fuel – refer to page 15 (Notes on Woodburning)	Ensure use of dry seasoned wood with less than 20% moisture content
	Over firing	High flue draught	Speak to your installer
		Air controls left fully open	Close air control to reduce output
	Low heat output	Low flue draught	Speak to your installer with advice on a suitable flue system.
		Wet wood (over 20% moisture content)	Ensure use of dry seasoned wood with less than 20% moisture content
Excessive fuel consumption	High flue draught	Speak to your installer	
	Over dry wood	Do not use constructional timber of pallet wood	
SMOKE PROBLEMS	Smoke and small flames	Wood with moisture content over 20%	Ensure use of dry seasoned wood with less than 20% moisture content
	Excessive smoke into room when appliance door is opened	Low flue draught	Speak to your installer
		Incorrect additional ventilation air in to the building	Speak to your installer
Continuous smoke spillage into the room when stove is in use	Blocked flue	Open all doors and windows to ventilate the room. Allow the fire to go out. Check flue for blockage. Do not re-use until the problem has been identified. If in doubt speak to your installer.	
ADVERSE WEATHER	Windy days causing spillage into the room	Down draught in flue caused by air turbulence due to nearby buildings or trees.	Weather conditions combined with the flue terminal position can have an effect on the stoves performance. Speak to your installer.
	Calm days causing spillage into the room	Over size flue giving poor flue draught	Weather conditions combined with the flue terminal position can have an effect on the stoves performance. Speak to your installer.
	Damp/Rainy days lighting and burning problems	Flue temperature low or rain water inside flue.	Use good quality wood to start and maintain the fire, speak to your installer to fit a rain cowl.
	Wind noise	High flue draught	Speak to your installer.

	ISSUE	CAUSE	RESOLUTION
THE APPLIANCE	Creosote build-up in chimney	Wood with moisture content over 20%	Use dry seasoned wood (less than 20% moisture content). Operate at a high temperature for short periods each time the appliance is used to avoid large build-ups of tars and creosotes.
	Tar coming from flue joints	Appliance operated at continuous low temperatures	Operate at a high temperature for short periods each time the appliance is used to avoid large build-ups of tars and creosotes. See user instructions for correct use of air control
		Using poor quality wood	Use dry seasoned wood (less than 20% moisture content).
	Dirty firebricks/glass	Wood with moisture content over 20%	Use dry seasoned wood (less than 20% moisture content).
	Glass blackening	Using poor quality wood	Use dry seasoned wood (less than 20% moisture content).
		Low flue draught	Speak to your installer.
		Incorrect use of air control	See user instructions for correct use of air control
		Appliance operated at low temperatures continuously	Operate at high output for short periods. See instructions for correct use of air control.

FLUES	Flue systems have two main functions:
	<ol style="list-style-type: none"> 1) To remove the smoke, fumes and combustion gasses from the building safely and efficiently 2) To provide a sufficient amount of flue draught (suction) in the appliance to ensure the fire keeps burning correctly. <p>The flue draught is caused by rising hot gases when the appliance is burning.</p> <p>If any flue issues persist then speak to your installer before continuing to use the stove.</p>

OPTIONAL EXTRAS

These can be purchased through our website www.hunterstoves.co.uk.

PRODUCT	CODE
Glass Cleaner (150mm Aerosol)	SCPGC
Fire Cement (500gm)	SCPFC500
Rope Glue (25ml)	SCPGLUE25ML
Gauntlet Gloves (Pair)	SCPGNTGLV
Touch up Paint with Brush (236ml)	SCPPB
Spray Paint (400ml)	40.011400
Operating Tool	HMR04ARRT025

Spares Information

Eco R4 Cube (All) (Complete Door Code: HMR04ARRT027)

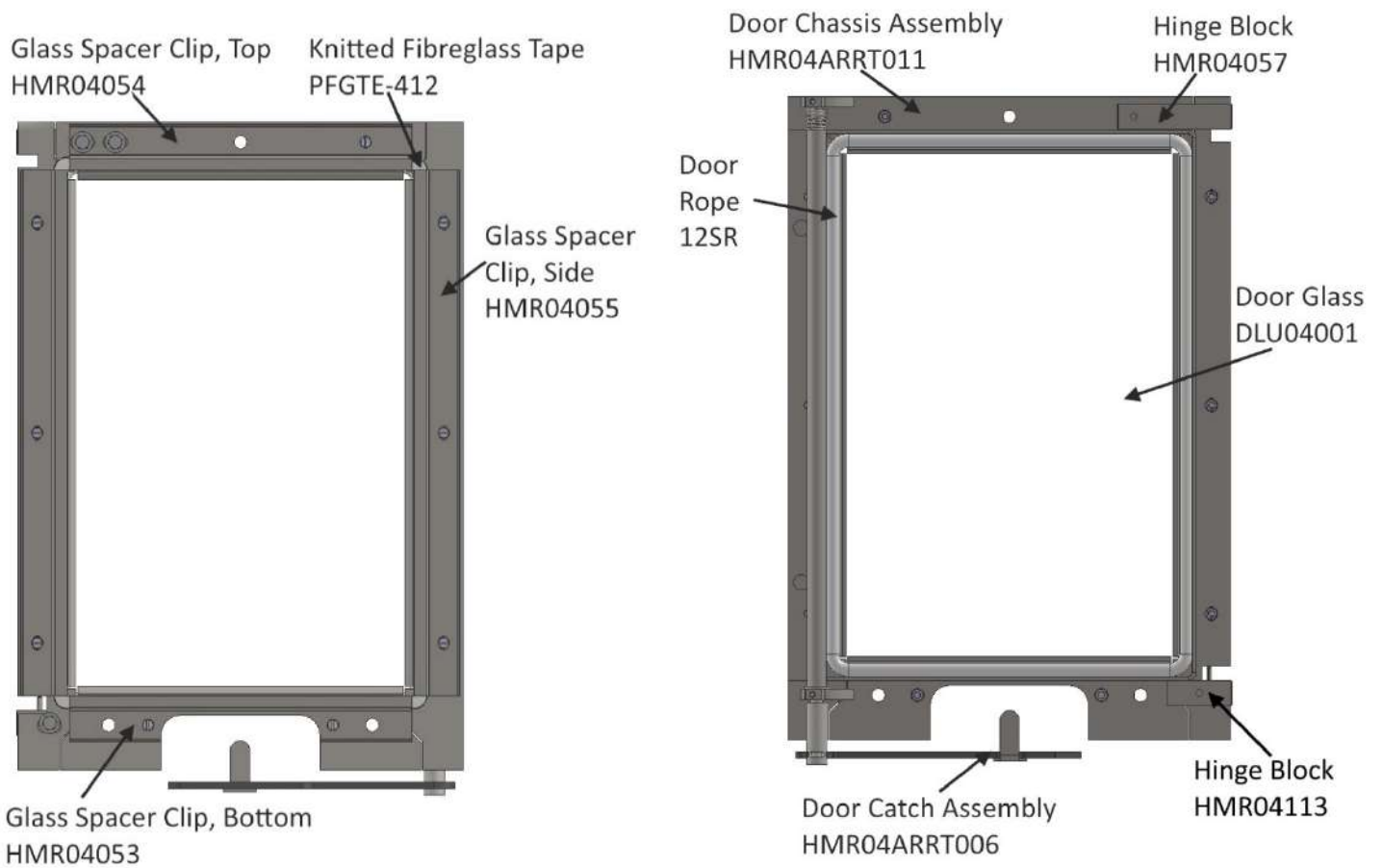

Eco R5 Cube (Both) (Complete Door Code: HMR05ARRT005)

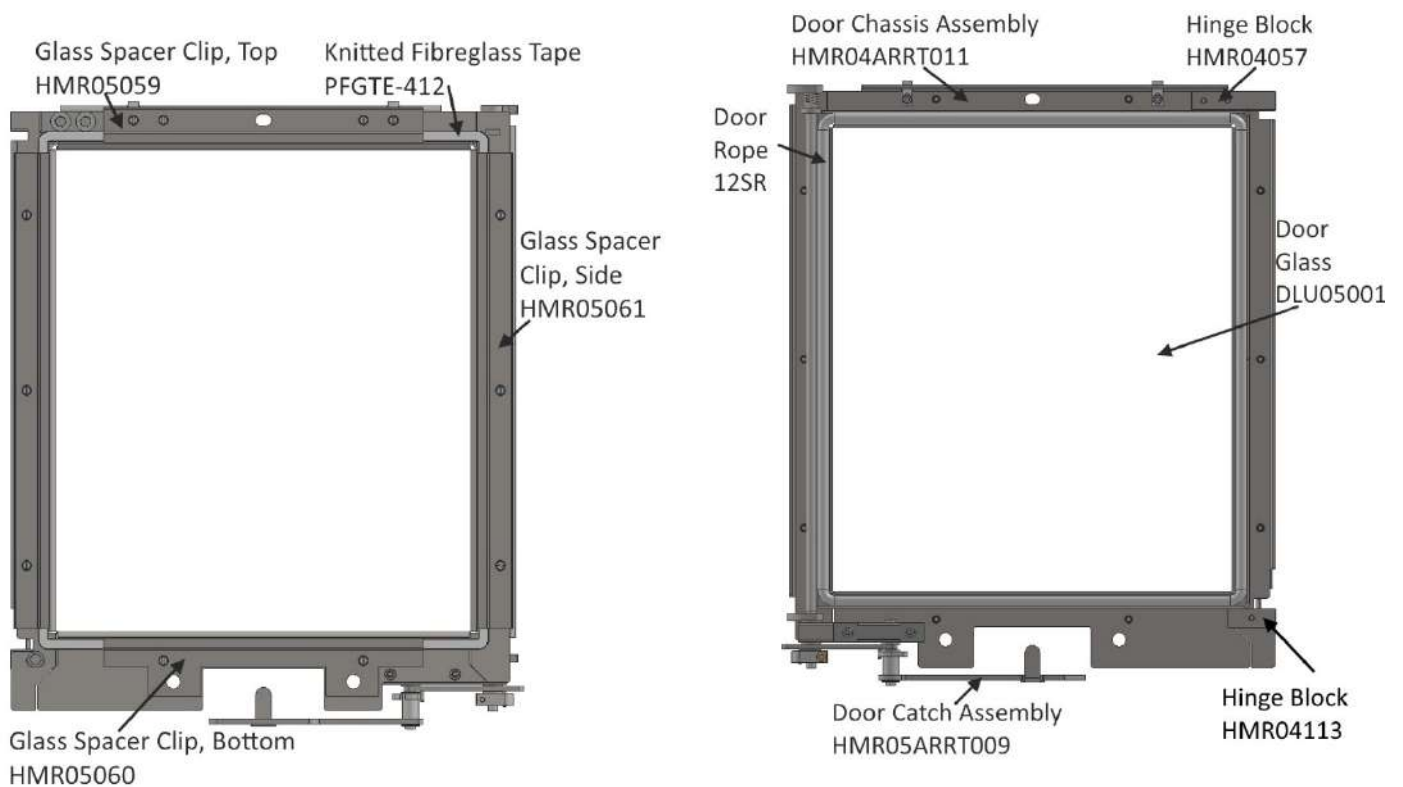

Eco R6 Cube (Both) (Complete Door Code: HMR06ARRT005)

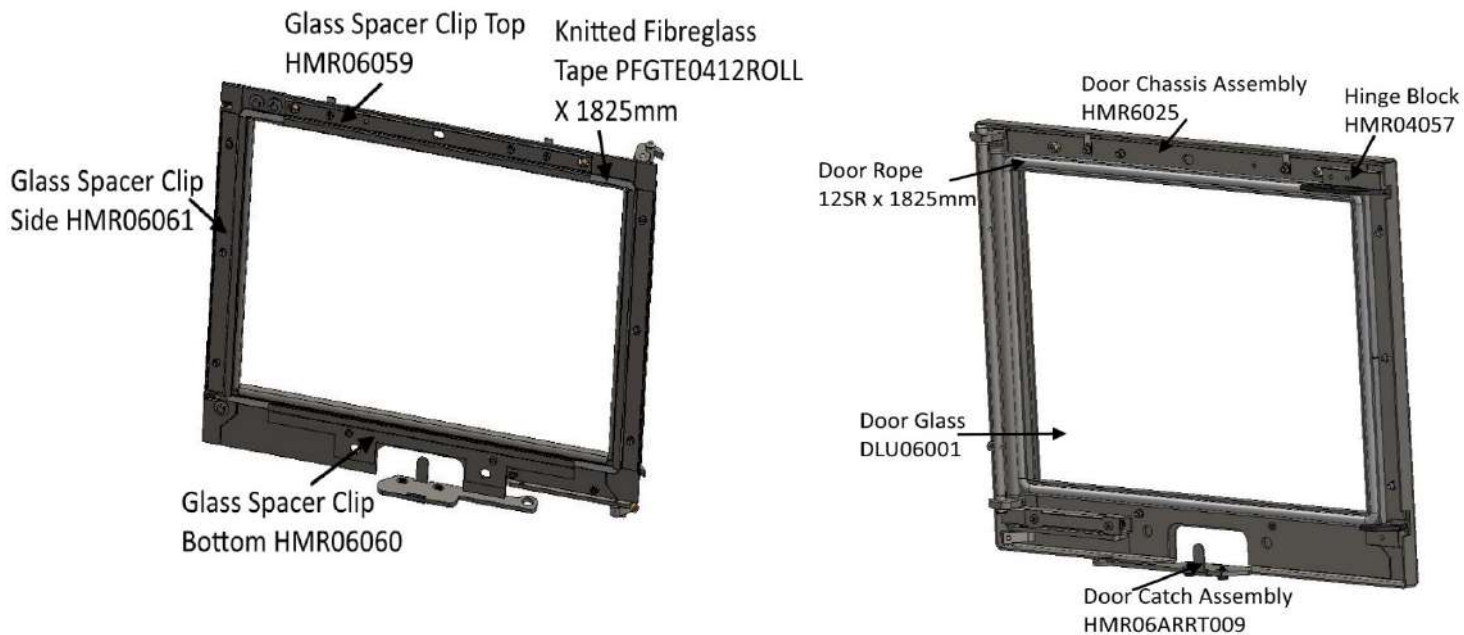

BODY ASSEMBLY SPARES

Eco R4 Cube (Both)

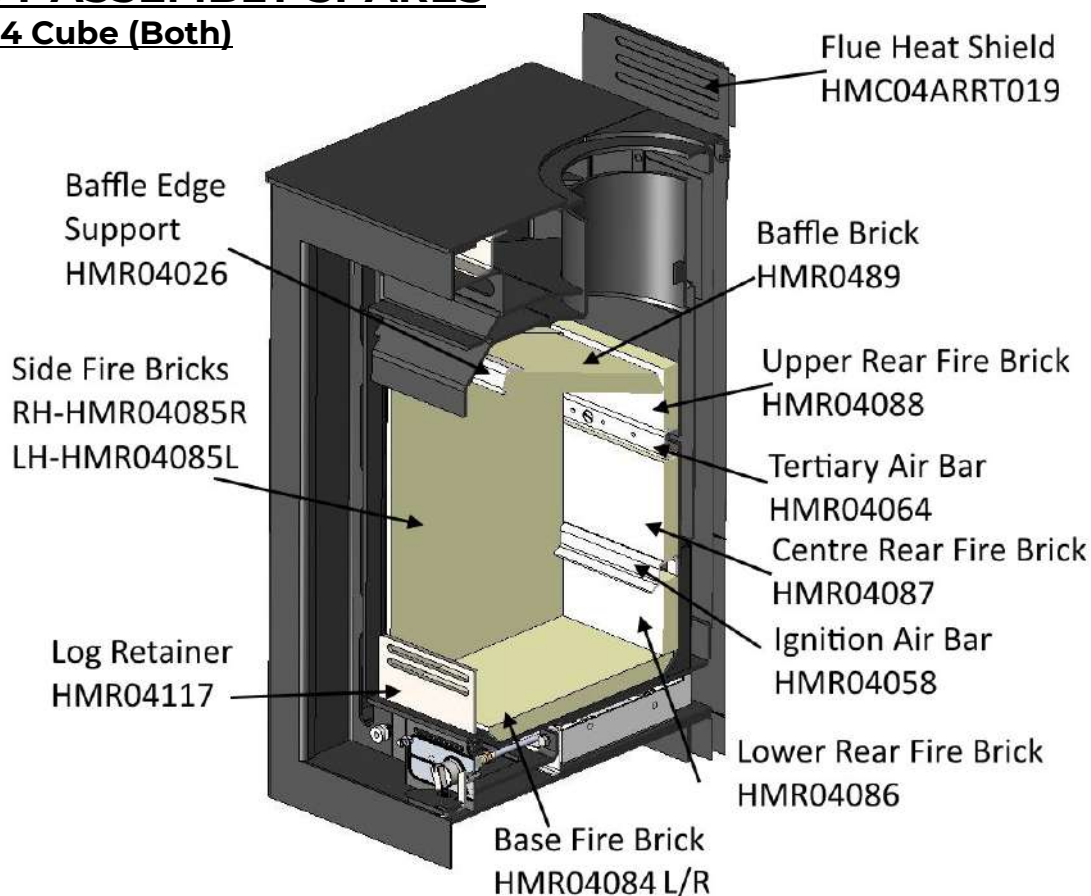

Eco R5 Cube (Both)

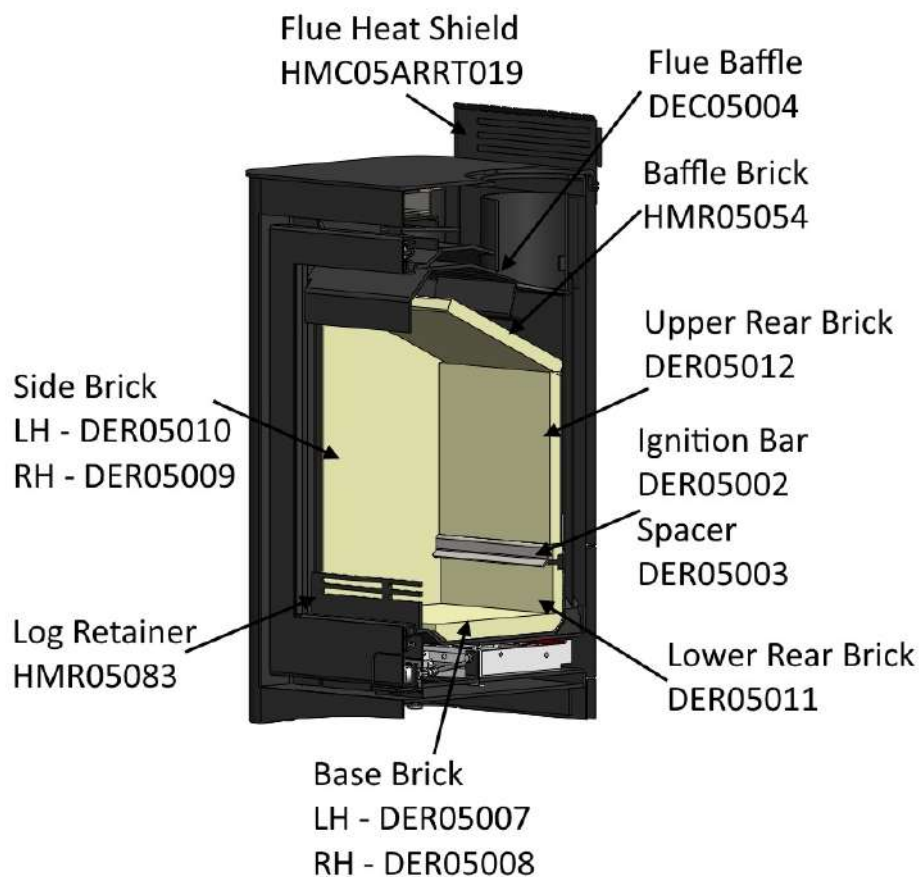

Eco R6 Cube (Both)

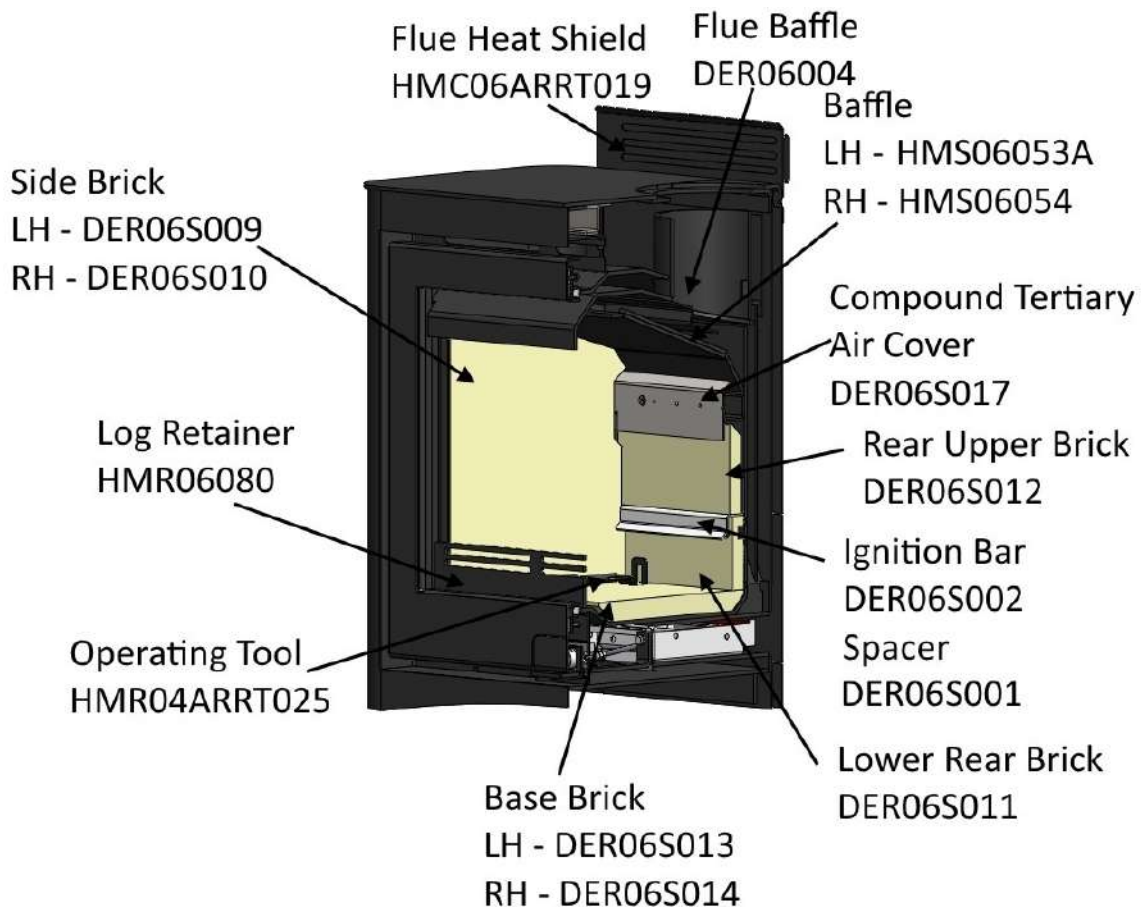

Air Controls

Eco R4 Cube (Both)

Complete Air Control Assembly HMR04ARRT004

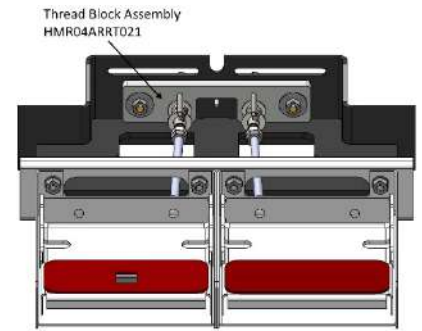
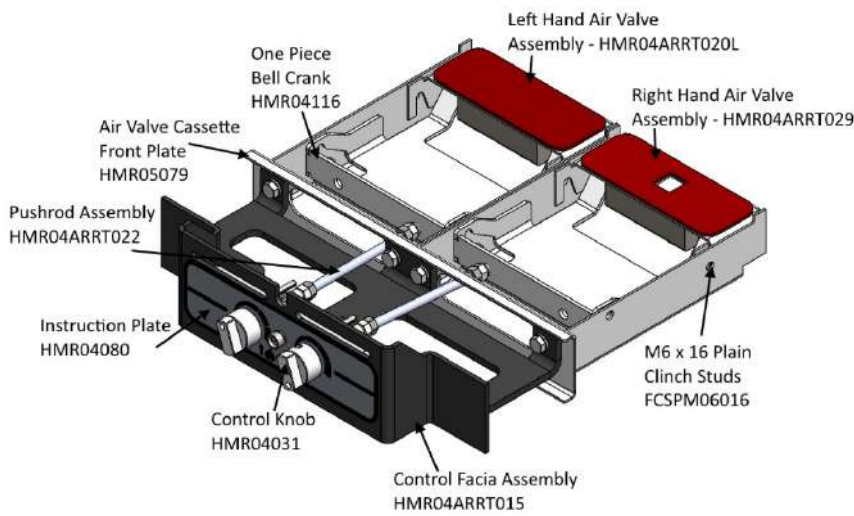

Di Lusso R5 (Both)

Complete Air Control Assembly DEE05ARRT009

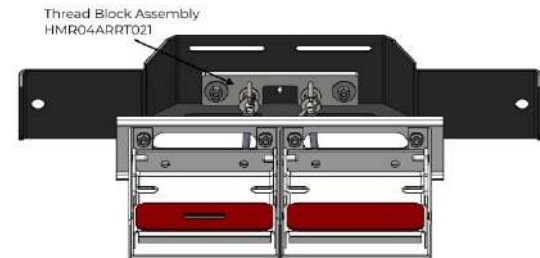
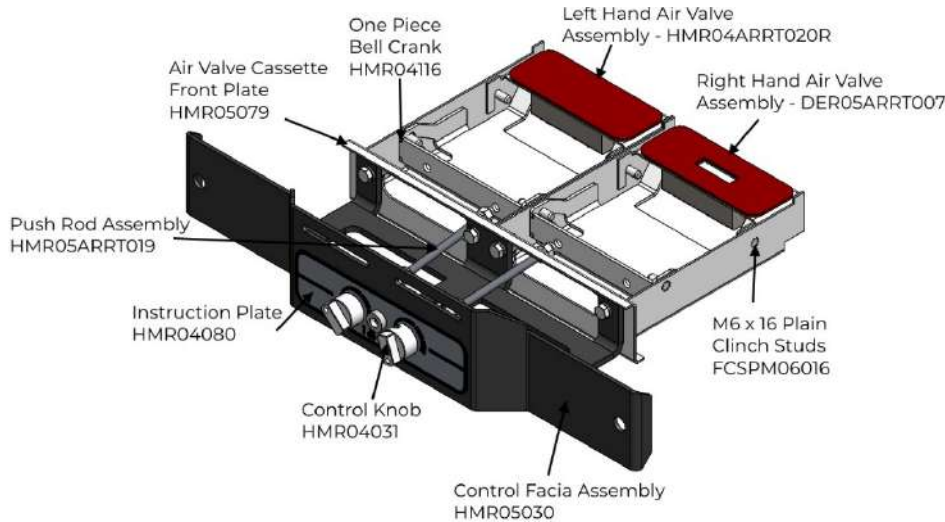

Di Lusso R6 (All)

Complete Air Control Assembly DER06ARRT008

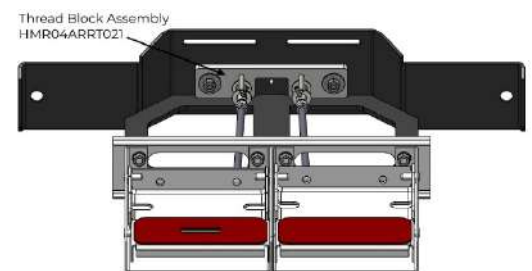
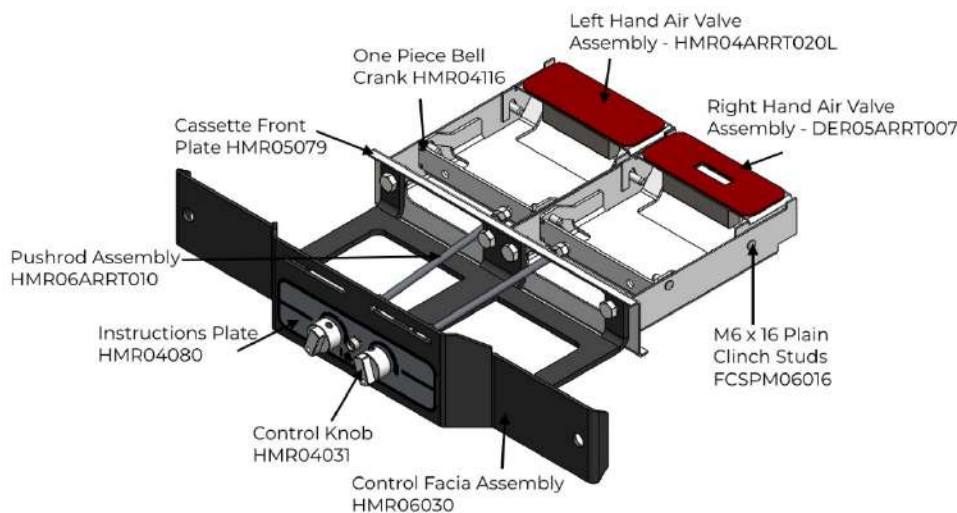

INSTALLATION & COMMISSIONING CHECKLIST

PURCHASE INFORMATION	
Dealer/Retailer Name	
Address	
Telephone Number	
Email	
Date Purchased	

INSTALLER INFORMATION	
Installer Name	
Address	
Telephone Number	
Email	

APPLIANCE INFORMATION	
Date Installed	
Appliance Stock Code	
Appliance Description	
Serial Number	

COMMISSIONING CHECK (Complete & Sign)		
	YES	NO
Does the chimney/flue system meet the appropriate standard?		
Has the chimney/flue system been swept and passed the soundness test?		
Has this appliance passed the flue draught test?		
Please write down the flue draught reading:		
Has this appliance passed the smoke test?		
Has this appliance passed the spillage test?		
Have you explained how to operate the appliance and explained the controls?		

Signature:	Print Name:
------------	-------------

SERVICE RECORDS

1st Service	
Date of Service	
Date of next Service	
Servicing Company/ Engineer	
Signature	

3rd Service	
Date of Service	
Date of next Service	
Servicing Company/ Engineer	
Signature	

5th Service	
Date of Service	
Date of next Service	
Servicing Company/ Engineer	
Signature	

7th Service	
Date of Service	
Date of next Service	
Servicing Company/ Engineer	
Signature	

9th Service	
Date of Service	
Date of next Service	
Servicing Company/ Engineer	
Signature	

2nd Service	
Date of Service	
Date of next Service	
Servicing Company/ Engineer	
Signature	

4th Service	
Date of Service	
Date of next Service	
Servicing Company/ Engineer	
Signature	

6th Service	
Date of Service	
Date of next Service	
Servicing Company/ Engineer	
Signature	

8th Service	
Date of Service	
Date of next Service	
Servicing Company/ Engineer	
Signature	

10th Service	
Date of Service	
Date of next Service	
Servicing Company/ Engineer	
Signature	

2 Year Standard Warranty

Any appliance bought through the showroom of an authorised Hunter Stoves Group dealership will automatically be covered by our standard 2-year conditional guarantee.

However, this standard 2-year warranty can be extended to a **5 year** or **10-year** conditional warranty dependent on the model type (5 years- Boiler model and Gas models, 10 years- Room heater).

To qualify for this extended warranty option, you need to:

1. Register your purchase online at <https://www.hunterstoves.co.uk/ProductRegistration>
2. Retain your proof of purchase.

Warranty Conditions

For the Standard 2 year or extended 5/10-year warranty to be valid and to remain in force throughout the warranty period the following must have been carried out:

1. The appliance must have been installed by an appropriately qualified engineer (from the Competent Person Scheme/Gas Safe) in accordance with the manufacturer's instructions and in compliance of any relevant national or local building regulations. Please visit the following links for details on the Competent Person Scheme: <https://www.gov.uk/guidance/competent-person-scheme-current-schemes-and-how-schemes-are-authorized> and Gas Safe register: <https://www.gassaferegister.co.uk/>
2. The appliance will need to be registered within two months of purchase and the commissioning and installation documentation completed (these need to be kept by the end user).
3. The appliance must be serviced within 12 months of the installation date for the second year of the standard warranty to be valid, and within every 12-month anniversary thereafter to maintain the validity and coverage of any extended warranty. For this purpose, the installation and user instructions, supplied with the appliance, makes a provision for receipts and annual services to be recorded. This is needed in the event of a claim during the warranty period.
4. Only genuine Hunter Stoves spare parts or consumables can be used in the servicing and maintenance of the appliance during any standard or extended warranty period. These can be sourced from your authorised supplier directly or through our website spares portal. www.hunterstoves.co.uk/spares.
5. Any problems or issues giving rise to any claim under the standard or extended warranty must be submitted to the authorised Hunter Stoves Group retailer from whom you originally purchased the appliance. Hunter Stoves Group will then offer appropriate support and help through your original authorised supplier to solve any issues.
6. The standard or extended warranty option is not transferable. It is solely for the benefit of the original purchaser of the appliance. For this purpose, please retain the proof of purchase.

Warranty Exclusions

No warranty period is extended to naturally wearing replaceable consumables and spare parts within the appliance. Such parts include, but are not limited to:

For Solid Fuel Stoves:

Glass and rope/ceramic seals
Fire bricks
Baffles/Throat plates
Log retainers, grate supports & catch bars
Grate parts
Ash-pans
Clip-in Boilers

For Gas Stoves:

Gas pilot assemblies
Thermocouples and Oxy pilots
Ceramic log & coal 'fuel -effects'

Paint and Surface Coverings

The paint or surface covering of the appliance will be covered (for 2 years after installation) provided the warranty conditions are met. However, damage due to the following events will not be covered:

1. Damage to the paint surface caused by the appliance being stored in a damp and cold environment is not covered under warranty. Please be aware that any moisture within the room where the stove is installed e.g. through clothes drying, can be a cause of paint issues.
2. In the course of the initial firings of the appliance the paint or enamel surface may change colour. This is normal and as such is therefore not covered under warranty.
3. Damaged caused by over firing, resulting in cracking, bubbling or discolouration to the paint or enamelled surface finish is not covered under warranty.

Warranty Limitations

1. Damage to the appliance due to specific local conditions caused by draft or chimney defects.
2. Damage resulting from installation and use where installation is not in accordance with the manufacturer's instructions or local building and/or safety regulations.
3. Damage or premature wear caused by burning inappropriate fuels such as Bituminous coal, "Petro-Coke" or any other Petroleum based coals. Please visit the HETAS website, www.hetas.co.uk, for a full list of approved fuels which are covered by the warranty. Fuels outside of this list are not covered by the warranty.
4. Damage caused by burning material with high creosote content or any other painted/treated timber.
5. Consequential loss to associated non-Hunter Stoves Group products is not covered under the warranty.
6. Consequential loss relating to decorations, soft furnishings or other household assets is not covered under the warranty.
7. Cost associated with the removal and re-installation of an appliance subject to a warranty claim.

Hunter Stoves Group total liability will only extend to the total purchase price paid for the goods in any warranty claim. Hunter Stoves Group reserve the right to replace, repair or refund to value of goods purchased.

ANY HUNTERS STOVES GROUP PRODUCT PURCHASED VIA AN INTERNET SUPPLIER, OR THROUGH AN UNAUTHORISED STOCKIST WILL ONLY BE SUPPORTED BY THE STATUTORY, 12 MONTH GUARANTEE AND WILL NOT QUALIFY FOR ANY EXTENDED 5- OR 10-YEAR WARRANTY.

The Hunter Stoves Group extended warranty option does not affect your statutory rights.

This revised standard or extended 5 or 10-year warranty option comes into effect on **1st September 2015** and will apply to all appliances sold from that date.

This standard/extended warranty applies to purchases of Hunter Stoves within the United Kingdom and the Republic of Ireland. Purchases in all other countries are subject to the warranty conditions specified by the distributor in those markets.



Hunter Stoves Ltd, 8 Emperor Way, Exeter Business Park, Exeter, Devon, EX1 3QS
www.hunterstoves.co.uk Email : info@hunterstoves.co.uk

Further Information

For extra guidance on using your stove, please visit our YouTube channel by searching 'Hunter Stoves Group' or see the helpful hints section of our website; www.hunterstoves.co.uk.

This appliance is suitable for intermittent burning.

This appliance should not be used in a shared flue.

All genuine Hunter Group spares can be purchased through our website www.hunterstoves.co.uk/spares or through your authorised dealer.

Di LUSO