

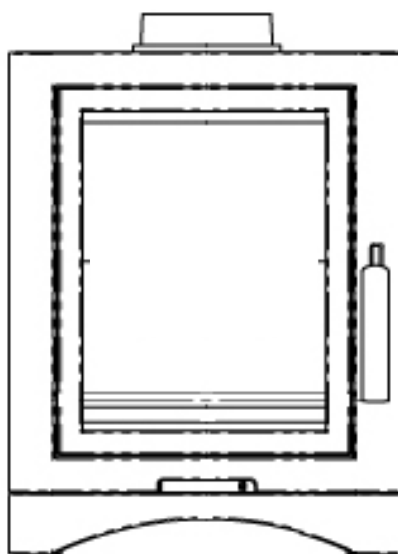

Installation & Operating Instructions



Covering Models:

eVolution 5
Wood Burning Stove
(Standard, Deluxe and Log Store Versions)

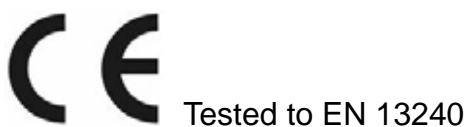

These appliances must be installed and commissioned by a HETAS registered engineer



Contents

| | |
|----------------------------------|----|
| Introduction | 3 |
| Packing List | 3 |
| Health & Safety | 4 |
| Specifications | 5 |
| Dimensions | 6 |
| Hearth Requirements & Clearances | 7 |
| Chimney Requirements | 8 |
| Combustion Air Requirements | 9 |
| Assembly | 10 |
| Assembly for Smoke Exemption | 12 |
| Stove Operation | |
| Controls Layout | 13 |
| Controls Explained | 14 |
| Air wash System | 14 |
| Ash Pan | 14 |
| Recommended Fuels | 15 |
| Lighting the Stove | |
| Kindling Stage | 16 |
| Burning Wood | 17 |
| Smoke Exempt Requirements | 18 |
| Warning Notes | 20 |
| Maintenance | |
| Ash Removal | 21 |
| Chimney Fires | 21 |
| Chimney Sweeping | 21 |
| General Stove Cleaning | 21 |
| Glass Cleaning | 21 |
| Annual Stove Service | 21 |
| Trouble-shooting | 22 |
| Commissioning Form | 23 |
| Spare Parts | 24 |
| EC Declaration | 25 |
| Annual Service Record | 26 |
| Warranty | 27 |



Introduction

May we take this opportunity to thank you for choosing one of our stoves.

These appliances are designed to burn wood logs and wood derived fuels. It is essential that your wood has been seasoned to ensure that it is sufficiently dry for burning. You can determine the moisture content of your logs by using a digital moisture meter, your logs need to be below 20% moisture content before they are considered dry enough for burning.

Never burn wood that contains paint, glue or any other chemicals

See the section “Lighting the Stove” for further details. After reading this document, if there is anything you are unsure about, please contact your dealer or our Technical Support Department.

These instructions cover the basic principles to ensure the satisfactory installation of the stove, although detail may need slight modification to suit particular local site conditions. In all cases the installation must comply with current Building Regulations, Local Authority By-laws and other specifications or regulations as they affect the installation of the stove.

It should be noted that the Building Regulations requirements may be met by adopting the relevant recommendations given in British Standards BS 8303, BS 6461 and BS 7566 as an alternative means to achieve an equivalent level of performance to that obtained following the guidance given in Approved Document J.

Please note that it is a requirement under the Broseley Fires warranty system that the installation of the stove is carried out by a Competent Person registered with a Government approved Competent Persons Scheme. HETAS Ltd operate such a Scheme and a listing of their Registered Competent Persons can be found on their website at www.hetas.co.uk.

Packing List

1x Cast Iron/Steel Stove
1x Rear Firebrick
1x Air Firebrick
1x Baffle
2x Baffle Spacers
2x Side Firebrick
1x Grate & Grate Support
1x Ashpan

Seperate Box Containing:
1x Spigot & Fixings
1x Spigot Ring
1x Ash Tool & Glove Set
1x Smoke Exempt Washer
1x Instruction Booklet

Deluxe Models Only:
1x Black Glass (Lid)

All parts will be inside the main stove body upon delivery.



Health & Safety

Special care must be taken when installing the stove such that the requirements of the Health and Safety at Work Act are met.

Installation

This appliance **MUST** be installed and commissioned by a HETAS registered installer in England and Wales and a fully qualified Heating Engineer in Scotland and Ireland.

Handling

Adequate facilities must be available for loading, unloading and site handling.

Fire Cement

Some types of fire cement are caustic and should not be allowed to come into contact with the skin. In case of contact wash immediately with plenty of water.

Asbestos

This stove contains no asbestos. If there is a possibility of disturbing any asbestos in the course of installation then please seek specialist guidance and use appropriate protective equipment.

Metal Parts

When installing or servicing this stove care should be taken to avoid the possibility of personal injury.

CO Alarms

Building regulations require that whenever a new or replacement fixed solid fuel or wood/biomass appliance is installed in a dwelling an audible carbon monoxide alarm must be fitted in the same room as the appliance. Further guidance on the installation of the carbon monoxide alarm is available in BS EN 50292:2002 and from the alarm manufacturer's instructions. Provision of an alarm must not be considered a substitute for either installing the appliance correctly or ensuring regular servicing and maintenance of the appliance and chimney system.

Fire Guards

When using the stove in situations where children, aged and/or infirm persons are present a fireguard must be used to prevent accidental contact with the stove. The fireguard should be manufactured in accordance with BS 6539.

Aerosol Sprays

Do not use an aerosol spray on or near the stove when it is alight.

Operating Tool & Gloves

Always use the operating tool and glove provided when handling parts likely to be hot when the stove is in use.



Specifications

In the UK these stoves have been approved by HETAS Ltd as intermittent heating appliances for burning manufactured or naturally occurring smokeless fuels and wood logs only.

| | |
|----------------------|-------------------------------|
| Heat Output: | 5 kW |
| Weight: | 100 Kg /139 Kg with Log Store |
| Flue Gas Mass Flow: | 3.3 g/s |
| Flue Gas Temp: | 215°C |
| Flue Draft Required: | 12-16 pa |
| Flue Outlet Size: | 6" / 150mm |
| Efficiency: | 85.5% |

European standards need to be complied to when installing this appliance.

Dimensions

All dimensions are in millimetres

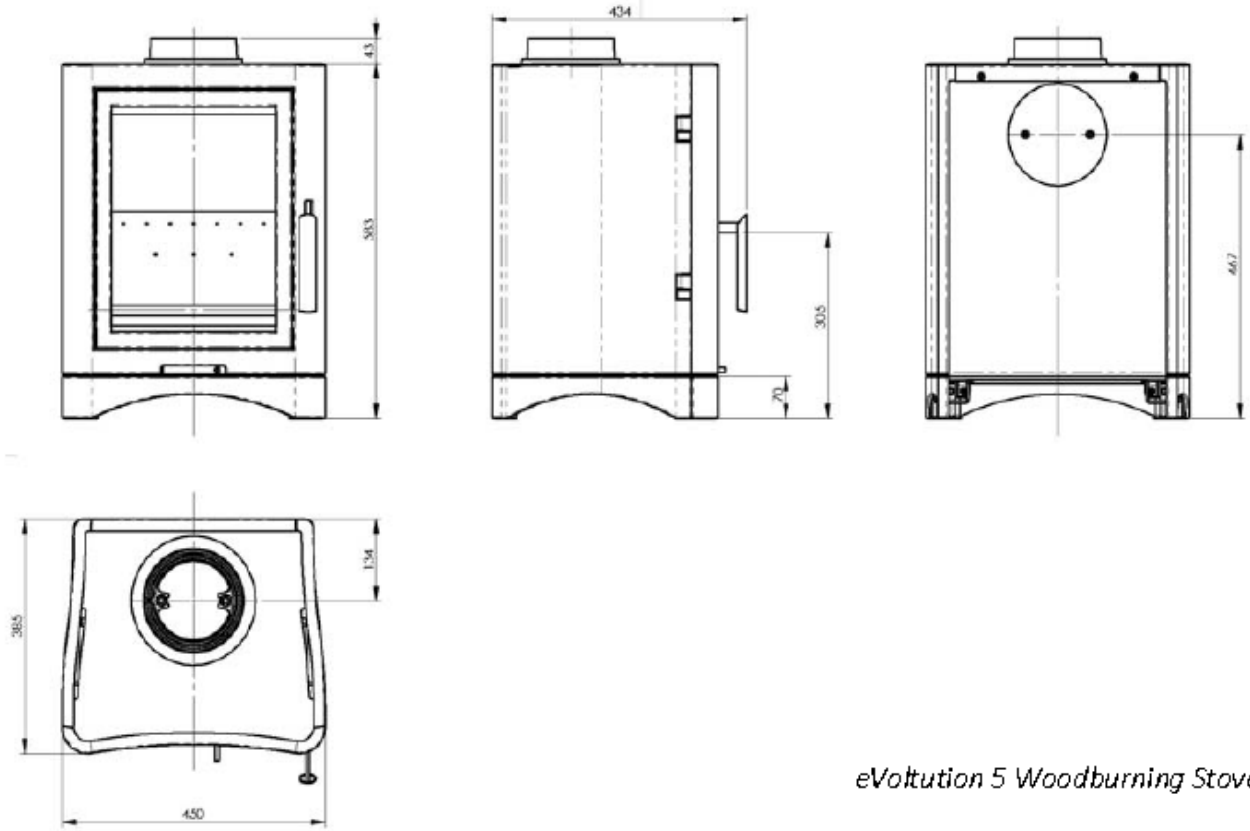

eVolution 5 Woodburning Stove

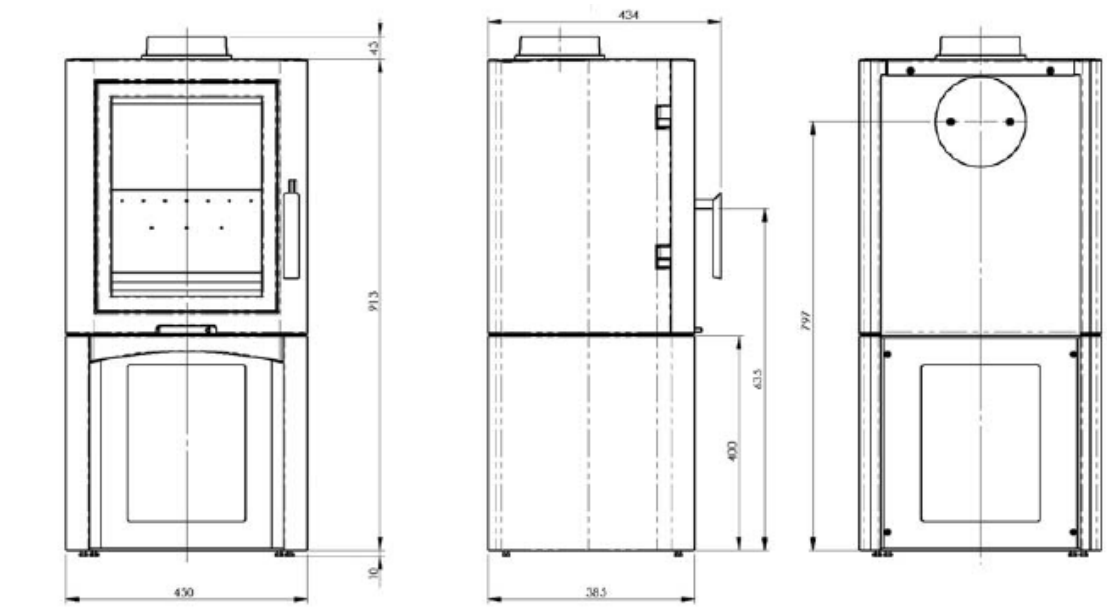

eVolution 5 with Log Store Woodburning Stove

Hearth Requirements & Clearances

These appliances are suitable for non-combustible hearths with a minimum thickness of 12mm, they do not require a full constructional hearth.

Your stove must be installed on a solid, level non-combustible hearth. The hearth protrusion in front of the stove to carpets or wooden floors must be at least 300mm. As it is possible, that on opening the door of the stove for fuel to fall out, a fender must be fitted if the hearth is flush with the finished floor level. These are just a few hearth specifications. Please refer to Building Regulations Approved Document J (Hearths) for more specific details.

Clearances

The stove requires the following clearances around it to ensure the heat is released into the room and to allow sufficient combustion air flow. A combustible material clearance is given to prevent damage to any items that may be affected by heat.

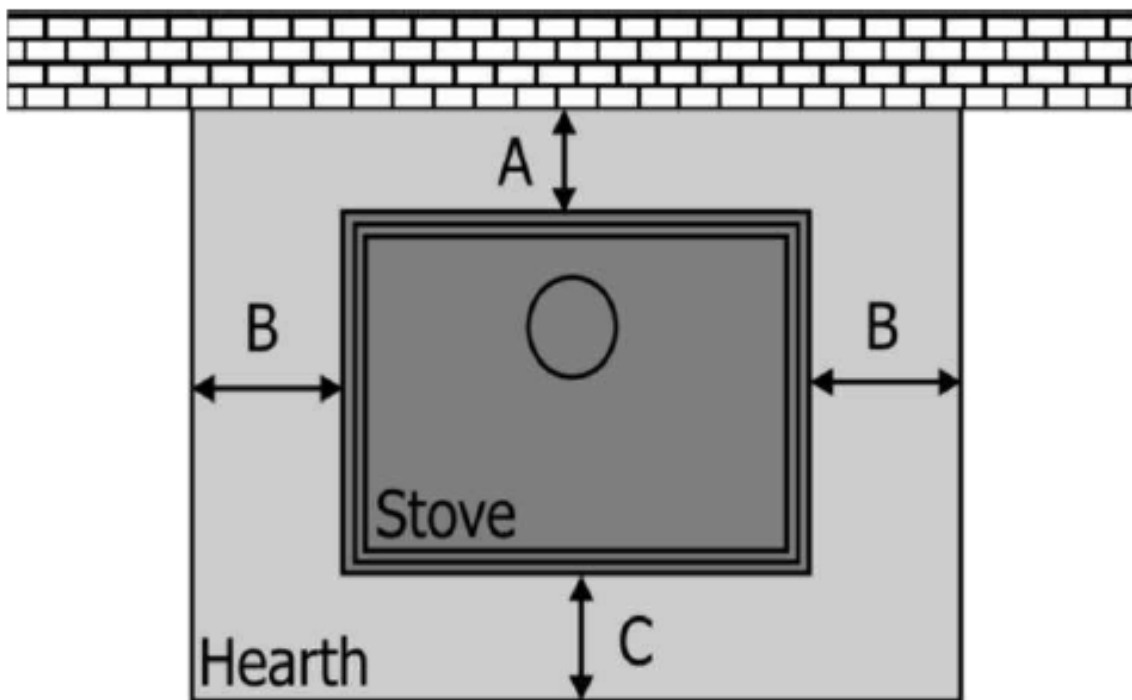

| Stove Clearances | A | B | C | Above |
|------------------|-------|-------|-------|-------|
| Non-Combustible | 100mm | 100mm | 300mm | 200mm |
| Combustible | 400mm | 180mm | 300mm | 600mm |

Chimney Requirements

This appliance must not be fitted into a chimney serving another heating appliance. It is most important that there is no obstruction in the flue or chimney. Please ensure that any existing chimney is clear of obstruction and swept clean immediately before installation of the new stove. If the chimney has been used for an open fire it is recommended that it be swept for a second time having been used for a month following installation.

A flue draught minimum of 12 Pascals to a maximum 16 Pascals is required for satisfactory appliance performance. A properly built masonry or factory constructed chimney (with a minimum vertical height of 5 metres) should ensure a consistent draught (draw). 45° bends can be used in the flue run (maximum of four bends) you will need to add an extra 1 metre of vertical flue height for each bend.

The flue draught should be checked under fire at high output and if it exceeds the recommended maximum, a draught stabiliser must be fitted so that the rate of burning can be controlled, and to prevent over firing (See section "Warning Notes"). If you have any doubts about the suitability of your chimney, consult your local dealer/stockist or engineer. If your flue draft is below the minimum recommendation then it may be necessary to increase the vertical chimney height, add additional flue insulation or possibly add a special cowl to the top of the chimney (e.g. anti down draft cowl to eliminate wind induced down draft).

The outlet from the chimney should be above the roof of the building in accordance with the provisions of Building Regulations Approved Document J.

If installation is into an existing chimney then it must be sound and have no cracks or other faults which might allow fumes into the house. Older properties, especially, may have chimney faults or the cross section may be too large i.e. more than 230 mm x 230 mm. Remedial action should be taken, if required, seeking expert advice, if necessary. If it is found necessary to line the chimney then a flue liner suitable for solid fuel must be used in accordance with Building Regulations Approved Document J.

If there is no existing chimney then either a prefabricated block chimney in accordance with Building Regulations Approved Document J or a twin walled insulated stainless steel flue to BS 4543 can be used. These chimneys must be fitted in accordance with the manufacturer's instructions and Building Regulations.

If a flexible liner is required the liner diameter must not be less than 6".

Any bend in the chimney or connecting fluepipe should not exceed 45°. 90° bends are not permitted. For top flue installations it is possible to sweep through the appliance by removing the internal baffle however it is recommended that you provide adequate access (e.g. easily accessible soot door). For rear flue connection we recommend the use of a tee section, the bottom of the tee should be capped to catch soot and debris.



Combustion Air Requirements

In order for the stove to perform efficiently and safely there should be an adequate air supply into the room in which the stove is installed to provide combustion air. This is particularly necessary in modern houses where drafts have been almost eliminated by double glazing etc.

Under UK building regulations any appliance over 5kW MUST have a fixed permanent air vent (see building regulations approved document J for further information).

There must not be an extractor fan fitted in the same room as the stove as this can cause the stove to emit fumes into the room. It is necessary to install a wall vent to provide the necessary combustion air and to prevent the depletion of oxygen in the room.

Assembly

The diagram below shows the stove with all internals taken out.

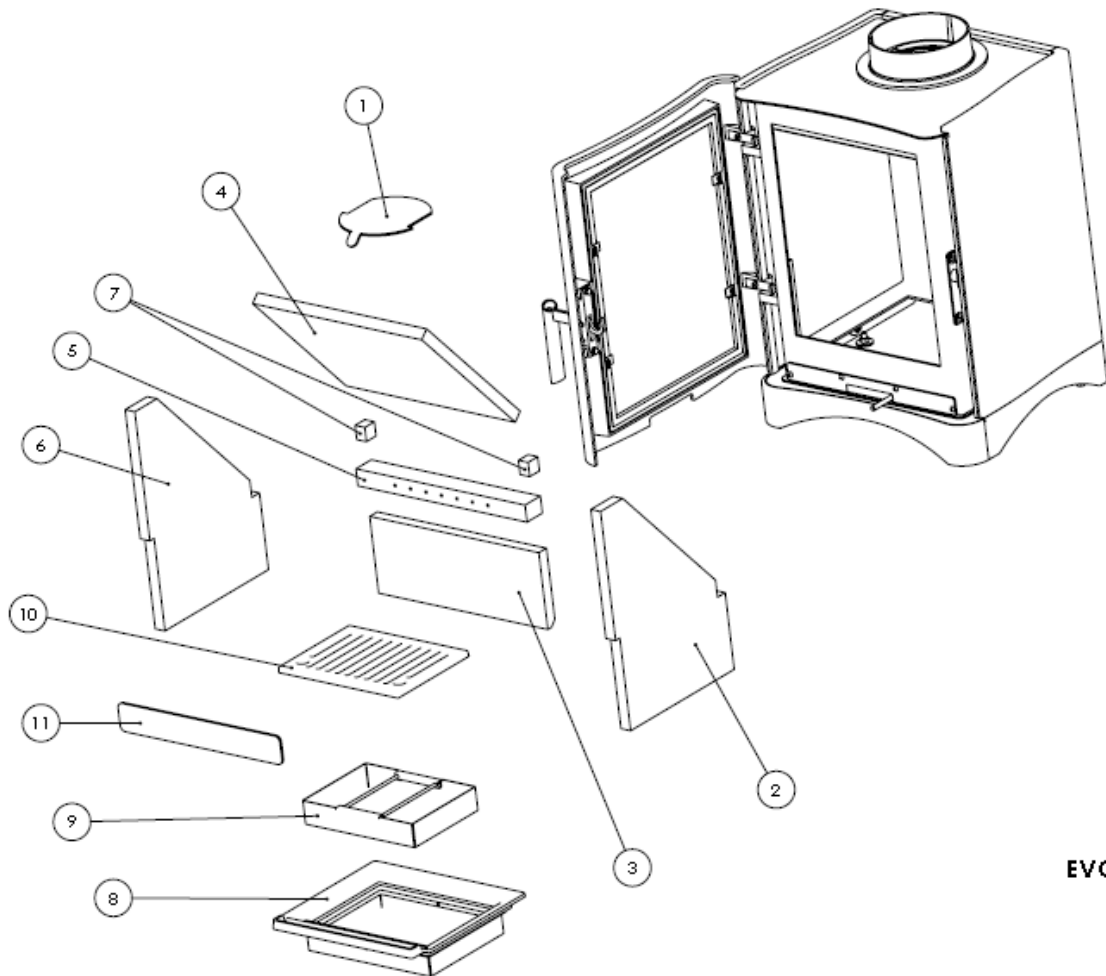

EVOLUTION 5

To install the internals simply follow the numbered sequence 0-11 and to remove simply reverse this process.

Please note the item numbered (1) is a steel secondary baffle, this is NOT a control and should be fitted fully pushed towards the back of the stove. The baffle should be left in at all times, it is only removable for chimney sweeping purposes the same as item (4).

Please Note on Item 6 (Airbrick) the smaller holes should face the glass.

Assembly

It is possible to convert the stove between standard and log store version (and vice versa) . The standard base can be unbolted (as shown below) and the stove installed onto the log store base. Simply reverse this process to change the stoves log base for a standard one.

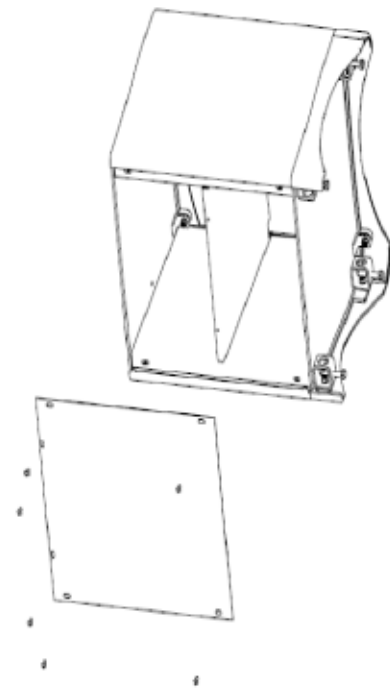
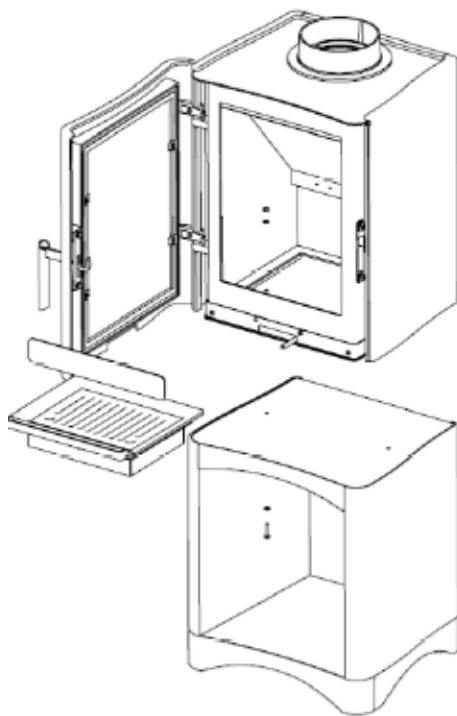
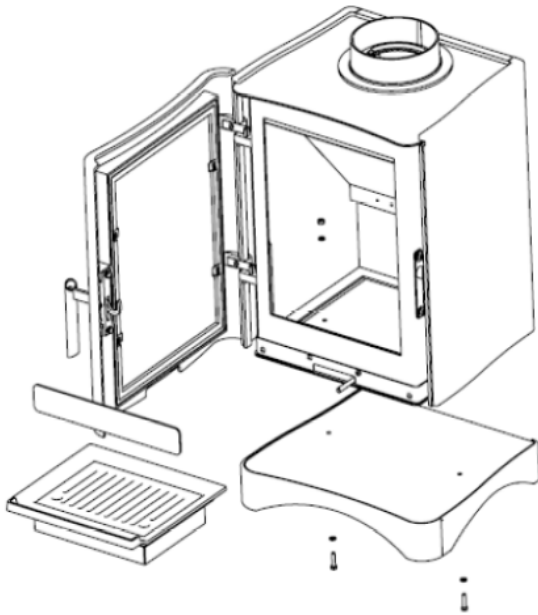

Assembly for Smoke Exemption

When installing this appliance into a smoke control area you will need to change the washer that sits behind the air slider to the smoke exempt washer (supplied). The smoke exempt washer ensures a constant supply of combustion air to meet smoke exempt requirements.

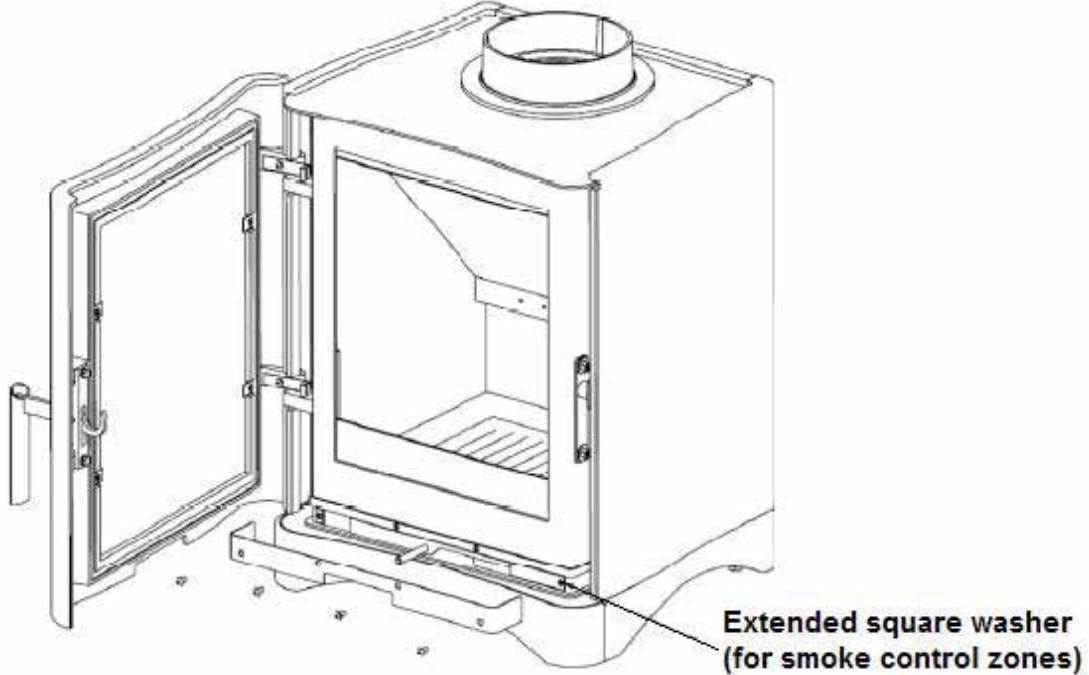
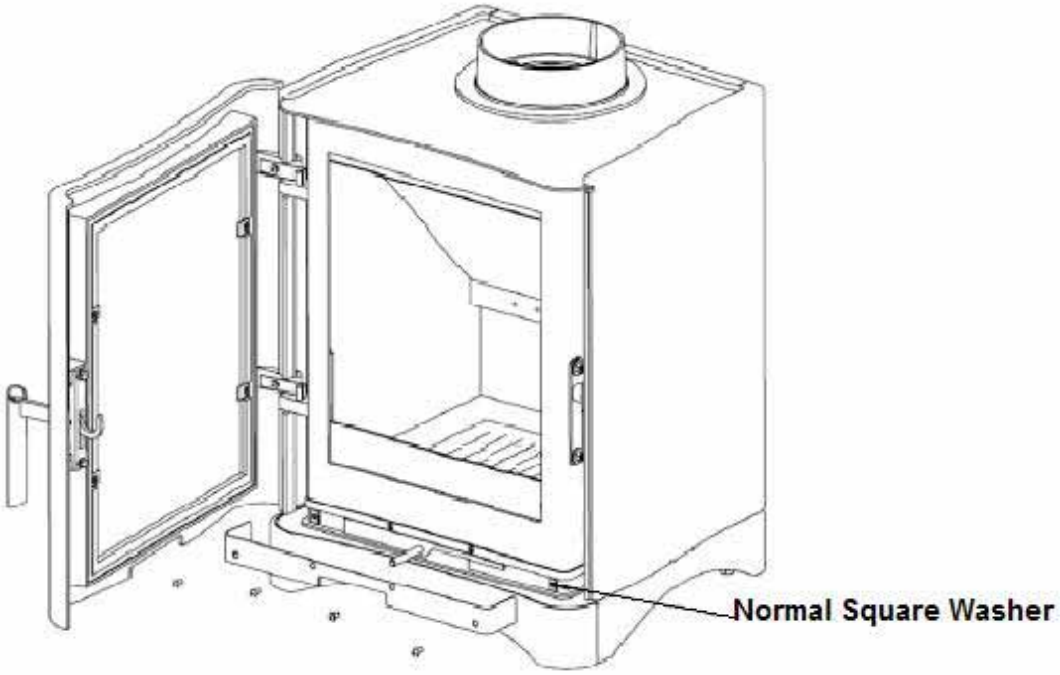

Controls Layout

The diagram below shows the position of the air control, this control needs to be operated correctly to control the combustion rate of the stove.

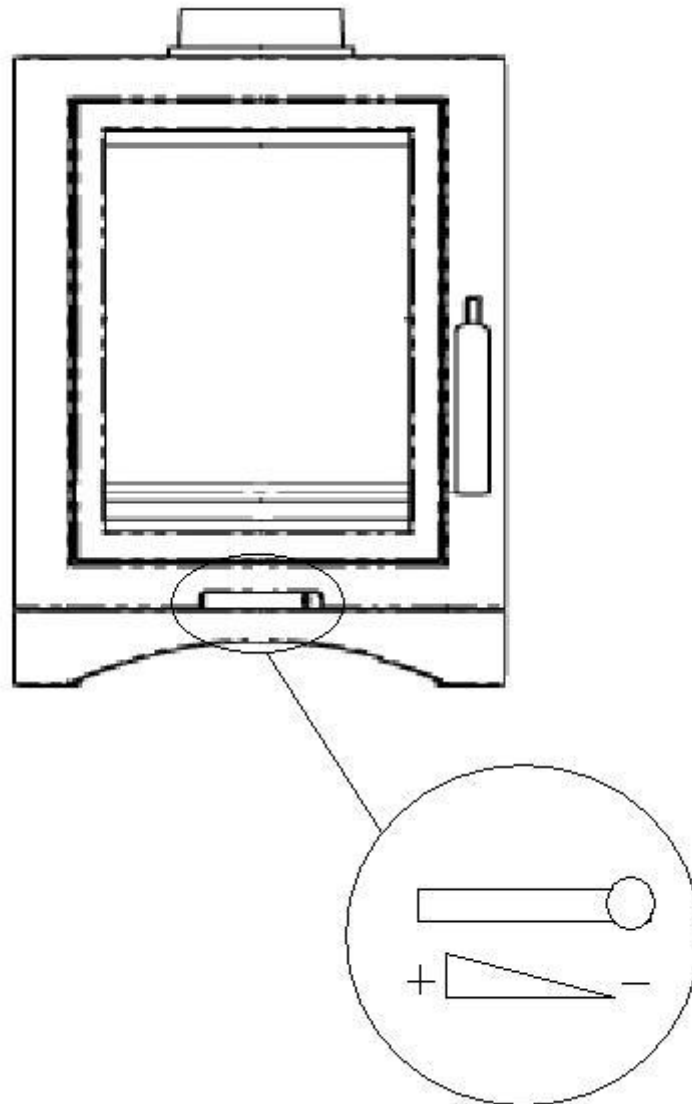

This air control is classed as the “**Secondary Air Intake**” as it brings air in above the grate. See the following section for a more detailed description of how this control works.

Controls Explained

Fire needs air to burn therefore the stove is fitted with an air control that allows you to regulate the amount of combustion air therefore controlling the burn rate within the appliance.

Secondary Air Intake

The secondary air intake is located on the front of the stove below the door, it is in the form of a slider. Having the slider pushed to the right indicates that the air intake is in the closed/minimum position and to the left indicates it is in the fully open/maximum position.

In smoke controlled areas you should fit the smoke exempt washer behind the control, this will prevent the control from fully closing.

Air entering through this control is directed through the holes in the air firebrick and also down the inside of the glass creating the **AIRWASH** system – see below. The air wash system reduces the amount soot and particle's making contact with the glass. This control is used at initial lighting and to control the burn rate of your wood.

The sections **LIGHTING THE STOVE & BURNING WOOD** gives a step by step guide on how to operate this control.

Air wash System

Air wash is a system where secondary air is drawn into the stove (by combustion) through the secondary air control and is deflected down the back face of the glass, thus preventing the smoke coming into contact with the glass. It does not mean that you will never have to clean the glass, but substantially lengthens the periods between having to do so. The air-wash system works best when burning dry wood. Wet wood will produce more deposits on the glass. Also, deposits will form on the back of the glass when the stove is operated on low heat for extended periods (where fuel is only just smouldering).

Ash Pan

The ash pan can be accessed by lifting out the grate. The tool can be used for this task. It is recommended that this is done when the stove is cold and not alight.



Recommended Fuels

This appliance has obtained approval from HETAS Ltd., for burning –

* Split Hardwood logs not exceeding 35cm in length and not over 20% moisture content.

Approval does not cover the use of other fuels either alone or mixed with the suitable fuels listed above.

Do NOT burn wet wood, This will give a poor heat output and will cause heavy deposits of soot and tar to accumulate on the glass and throughout the stove and flue. The coating of soot and tar in the chimney is volatile creating a high risk of chimney fires. A growing tree contains a high percentage of water, the wood needs to be dried out (seasoned) before it is suitable for burning (this can take several years). Wood logs are best stored in a stack, sheltered from the weather, in a well ventilated area and raised off the ground. This allows the air to circulate and prevents mildew.

Do NOT burn Pallet Wood, or any other wood containing glue, paint or any other chemicals. Burning such fuel will result in damage to your appliance, any such damage will not be covered by the products warranty.

Lighting the Stove

Curing

On initial firing you will notice a very pungent odour, this is caused through the curing of the paint, we recommend starting with short burning sessions (with smaller quantities of fuel) and build up gradually to allow the components of the stove to settle. Opening doors and windows will allow the paint curing odour to dissipate and to allow ventilation into the room. Curing times can vary but typically should take around 8-12 hours (operation at nominal output) to complete.

Kindling

Stage 1

With the Secondary air intake slider (below door) in the fully open position and the door open, start your fire using twists of newspaper (or scrunched up balls). Form a bed on the grate using the newspaper, then add a generous amount of dry kindling onto the newspaper. Ensure there is sufficient air gaps between the kindling (a criss cross or pyramid style pattern is ideal to accomplish this). Firelighters can also be used for this task.

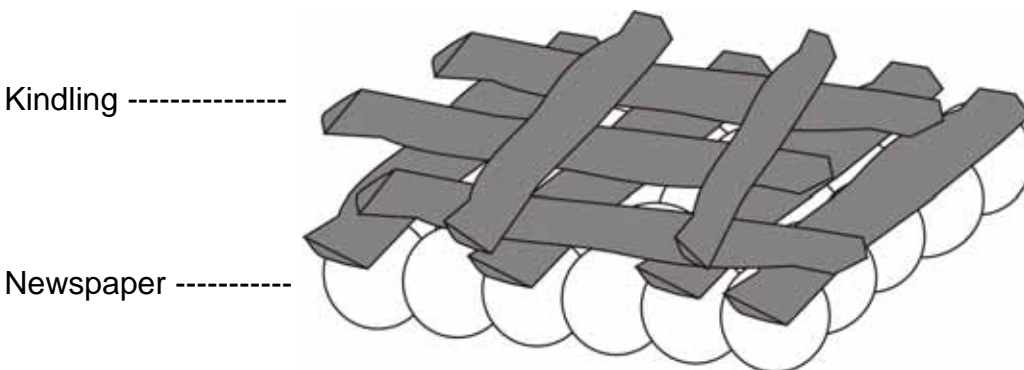

Stage 2

Ignite the paper underneath using a match or suitable fire-lighter. Allow the paper and kindling to burn until it reduces down into hot embers. If the fire is dying during this stage the door can be closed but not latched leaving a small gap for extra combustion air.

Stage 3

Add another generous load of dry kindling and allow to burn down.

It may be necessary to repeat stage 3 if the chimney is cold or if you find you have smoke entering the room. This stage is vital for getting heat into the chimney which will create the draw that takes the smoke away, we would expect this stage to take between 15-20 minutes.

It is critical that you do not leave the stove during the entire lighting and kindling stage. See Burning wood section for the next steps in the sequence.



Burning Wood

Once you have kindled your stove (see previous page) and your chimney (flue) is sufficiently heated, you are now ready to start adding you logs.

Stage 4

Place 1-3 small logs onto the bed of hot embers using the gloves provided, close the door but leave the Secondary Air Control in the fully open/maximum position. Allow the logs time to fully ignite and turn black.

Stage 5

Once the smaller logs have burned down you can now add 1-2 larger (or full size) logs, allow time for the logs to fully ignite (Turn black) then close down the Secondary Air Intake as required. You can now control the burn rate of the stove using the secondary air intake. You are looking for a controlled flame (not smouldering in the embers or licking around the lid) this is mostly visual although a flue pipe thermometer will help you determine the amount of air required and is recommended for the initial lightings.

Stage 6

Refuel as and when required. Open the secondary air intake fully when refuelling and allow the new fuel to ignite (Turn black). Control the combustion as per stage 5. Take care to open the door gradually as flames may lick out and always use the gloves. Try to avoid closing the Secondary air control fully (as this will cause the stove to fill up with smoke). If you no longer want to keep the fire going simply allow it burn out.

Please note this is the standard lighting sequence, if you are in a smoke control zone there is an alternative sequence which can be found in the SMOKE EXEMPT REQUIREMENTS section – next page.

Smoke Exempt Requirements

The eVolution 5 Wood burning stove has been tested by GASTEC under the PD6434 standard and has passed the emission requirements for exemption under the Clean Air Act. Subsequently it has been exempt for use in smoke control areas when burning wood only.

Smoke emissions from the appliance were measured over three main air control settings representing high, medium and low outputs. The three output test conditions undertaken in the present report were conducted with the air control **(i) fully open – high output, (ii) 85% open – medium output and (iii) 70% open – low output**

The low setting used was not the minimum setting for the control, the minimum air control setting would give very poor smoke reduction since it was possible to starve the appliance of air almost completely. A low setting that maintained clean combustion was determined and used as the low output setting (70%).

There is a requirement for the door to be left ajar for 5 minutes immediately after refuelling. This is to ensure that flames are well established on the newly charged logs and that they become fully blackened. Additionally, for medium and low output burning, the air control must be maintained at 100% open for the first 5 minutes after refuelling at which time it is possible to adjust to the required settings as identified above.

Ignition Sequence (Smoke Exempt Areas)

The procedure adopted for ignition is to build a bed in stages and to warm the body of the appliance and the chimney as quickly as practicable.

Firstly kindling, weighing approximately 1 kg will need to be lit (using a chemical firelighter is recommended) with the air control fully open. The door must be pushed against the appliance but then left ajar.

After about 10 minutes, when the fire from the kindling is beginning to die back, two small logs can be added. When these are alight and fully blackened, the door can be closed. This, typically, takes approximately a further five minutes.

When the fire is again beginning to die back, a full load of two logs, weighing about 1.3 - 1.4 kg, can be added: typically this takes 20 – 25 minutes from the start of the ignition sequence. The air control must be maintained in its fully open position for the remainder of the ignition sequence. Once the fuel has blackened the fire can then be allowed to burn down to a suitable condition at a preferable air slider position. For start of further refuelling apply sequence in the previous 2 sentences.

Smoke Exempt Requirements

1. It is important to follow the smoke exempt instructions in order to achieve clean burning and to maximise the efficiency from the stove
2. Do not leave the fire unattended after refueling until flames are well established on the newly charged logs
3. **Refuelling on to a low fire bed** If there is insufficient burning material in the firebed to light a new fuel charge, excessive smoke emission can occur. Refuelling must be carried out onto a sufficient quantity of glowing embers and ash that the new fuel charge will ignite in a reasonable period. If there are too few embers in the fire bed, add suitable kindling to prevent excessive smoke
4. **Fuel overloading** The maximum amount of fuel specified in this manual should not be exceeded, overloading can cause excess smoke.
5. **Operation with door left open** Operation with the door open can cause excess smoke. The appliance must not be operated with the appliance door left open except as directed in the instructions.
6. **Dampers left open** Operation with the air controls or dampers open can cause excess smoke. The appliance must not be operated with air controls or dampers door left open except as directed in the instructions.

Warning Notes

Over-Firing

It is extremely important that you do NOT leave the air control in the fully open position for extended periods or run the appliance with the door open. Leaving the air control fully open (or running with the doors open) will lead to “over-firing”. Over-firing is caused when too much heat is generated within the fire chamber, this will lead to warping, buckling and general damage to the stove and its internal components. Over-firing can also be caused by an excessive flue draft.

PLEASE NOTE ANY DAMAGE TO THE APPLIANCE CAUSED THROUGH OVER-FIRING WILL NOT BE COVERED BY THE WARRANTY.

Fumes

Properly installed, operated and maintained, this appliance will not emit fumes into the dwelling. Occasional fumes may occur whilst de-ashing and re-fuelling. However, persistent fume emission is potentially dangerous and must not be tolerated. If fume emission does persist, the following immediate actions should be taken:-

- a) Open doors and windows to ventilate the room
- b) Let the fire go out or eject and safely dispose of fuel from the appliance
- c) Check for flue or chimney blockage and clean if required
- d) Do not attempt to relight the fire until the cause of the fume emission has been identified and corrected. If necessary seek expert advice

Firebricks

Vermiculite is an industry recognised robust fireproof material which is used by many stove manufacturers to produce internal firebox linings (firebricks). With care vermiculite firebricks will give many years of faithful service.

It is important that care is taken whilst refueling your stove in order to protect the internal vermiculite parts from premature failure.

Never throw or drop logs into your stove as this will potentially damage your firebricks and may also result in logs bouncing out of the appliance (creating a possible fire risk). Open the door an inch initially (allowing the fire to settle) then slowly open the door and gently place the log(s) onto the grate. Always use the glove (provided) when refueling to avoid the common scenario of dropping the logs in quick (because it's hot).

Take care when clearing the ash and using the poker tool not to strike and potentially damage your firebricks.

Always take care when removing the firebricks to avoid damaging them. It may be necessary to remove the firebricks during general maintenance and chimney sweeping.

Impact damage is the most common cause of cracked vermiculite firebricks; however it is also possible to crack the firebricks if you over fire your appliance.

Maintenance

Ash Removal

The ash pan can be accessed by lifting out the grate. The tool can be used for this task. It is recommended that this is done when the stove is cold and not alight.. We would recommend emptying the ash into a metal bucket for transportation.

You should only empty the ash when the appliance and ashes are completely cool and can be disposed of in your normal household refuse.

Chimney Fires

In the event of a chimney fire ensure the Secondary air control is fully closed and the door remains closed at all times. If the chimney fire does not go out or if there is a serious risk to people and property, call the fire brigade immediately.

Regular sweeping of the chimney will remove combustible particles and will reduce the risk of chimney fires. If you have experienced a chimney fire it is recommended you seek expert advice before using the appliance again.

Cleaning the Stove

We recommend only doing this when the stove is cold using a soft brush to clean any of the stove surfaces, this is normally sufficient to remove dust, ash and debris. For stubborn marks you can use a damp lint free cloth, ensure that all surfaces are dried off immediately. We do not recommend using any kind of chemicals or abrasive materials. It is possible to touch up the paint using the original metallic black stove paint, however this new paint will then need to cure.

Glass Cleaning

A damp lint free cloth is normally sufficient, however for stubborn build ups we would recommend using a very fine wire wool.

Chimney Sweeping

It is essential that your chimney (flue) is swept at least once a year by a registered professional chimney sweep. Sweeping removes particles that could otherwise fuel a chimney fire, it should also highlight any potential issues such as leaks and damage to the flue.

Stove Servicing

Your stove should be inspected annually to ensure all seals are present and correct and to gauge the condition of the internal firebricks. The service should be done by a HETAS registered engineer who also perform a spillage test.

Trouble-shooting

Smoke comes out of the stove when the loading door is opened.

- The chimney cavity into which the 150mm flue pipe has been installed may be less than the minimum requirement.
- Deposits (soot or other obstructions) may have built up in the chimney and be restricting the flow of waste products. This flow rate is known as the 'draw'.
- Insufficient draw, this is especially common during milder weather. You will need to prolong the kindling stage to ensure the chimney (flue) is completely hot (you may even need to pre-heat the chimney using a method advised by the installer)
- Combustion air intake is not large enough or another appliance (e.g. Extractor fan) is taking air away from the stove.

The Stove does not produce the expected heat into the room.

- Has the flue pipe been sealed to the chimney to prevent heat being drawn up the chimney to waste?
- Green or wet wood is being burnt.
- The chimney has excessive draw (this is unusual). Seek installer advice with regard to installing a Flue Draught Stabiliser.
- The stove has been recessed into the existing fireplace and a lot of heat is being absorbed by the surrounding fireplace walls rather than being radiated into the room. Pull the stove forward.
- For the maximum efficiency of heat transference into the room the stove should be sited on the hearth of the fireplace rather than recessed.

The Stove burns too fast.

- Use whole logs rather than split ones.
- The wood being used may be generally too small.
- The "air-tight" seal between the fibre rope on the doors and the casting may have been lost, adjust door handle lock nuts to reinstate this seal or replace.
- The chimney has excessive draw (seek installers advice on this point).
- The fibre rope seal between the door and the glass may be leaking. Tighten or replace.
- The fibre rope on doors and glass has worn out. Replace.



Commissioning Form

Commissioning Statement and Check-list

Stove Purchased From: _____

Address: _____

Telephone Inc area code: _____

Installation Date: ____/____/____ Stove Name: _____

Product Serial Number: _____ Invoice Number: _____

Stove installed by: _____

Address: _____

Telephone Inc area code: _____

HETAS Registration Number: _____

Check-list

- Is the flue system the correct length and diameter for stove: Yes No
- Flue swept and checked for soundness: Yes No
- Manufacturers clearances adhered: Yes No
- Smoke spillage test performed on stove: Yes No
- Stove controls fully explained to end user: Yes No
- Correct fuels explained to end customer: Yes No
- CO Alarm fitted and tested: Yes No
- Instruction booklet & HETAS certificate handed to end user: Yes No

Signature: _____ Print Name: _____

Spare Parts

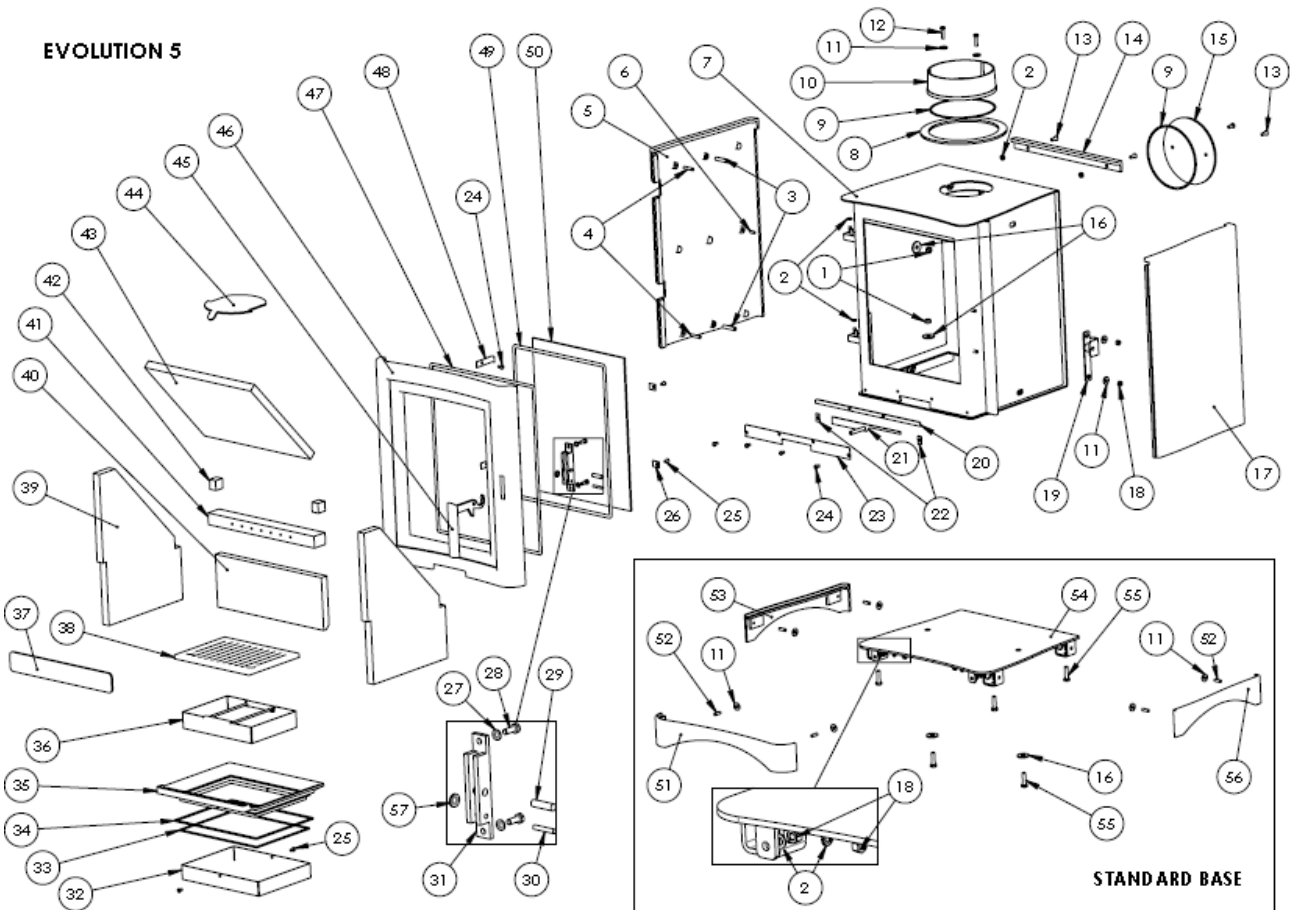

- (1) M8 Nut (2) M6 Washers (3) M8 Threaded Rod (4) M8 Threaded Spacer (5) Left Side Casting (6) M8 Nut (7) Steel Body Assembly (8) Spigot Ring (9) 6mm Rope (10) Spigot (11) 8mm Washer (12) M8 Bolt (13) M6 Screw (14) Rear Casting (15) Blanking Plate (16) 8mm Washer (17) Right Side Casting (18) M6 Screw (19) Door Handle Latch (20) Rear Slider Guide (21) Slider (22) Slider Washer (23) Front Slider Guide (24) M6 Screw (25) M6 Glass Clip Screw (26) Glass Clip (27) M8 Washer (28) M8 Bolt (29) Handle Rod (30) Handle Stop Rod (31) Handle Bracket (32) Ashpan Housing (33) 6mm Rope (34) 8mm Rope (35) Grate Support (36) Ashpan (37) Log Retainer (38) Grate (39) Side Vermiculite (40) Rear Vermiculite (41) Air Tube ermiculite (42) Vermiculite Spacer Block (43) Vermiculite Baffle (44) Steel Baffle (45) Handle (46) Door Casting (47) 10mm Rope (48) Smoke Exempt Washer (49) 6mm Rope (50) Glass (51) Base Front Casting (52) 6mm Spacer Rod (53) Left Side Base Casting (54) Steel Base (55) M8 Levelling Bolt (56) Right Side Base Casting



EC Declaration



DECLARATION OF CONFORMITY
ACCORDING TO DIRECTIVES 89/106/EEC (CONSTRUCTION PRODUCTS)



ISSUED BY: **BROSELEY FIRES LTD**
KNIGHTS WAY, BATTLEFIELD ENT PARK.
SHREWSBURY. SY1 3AB ph: +44 (0)1743 461444

TYPE OF EQUIPMENT: WOOD BURNING STOVE

TRADEMARK: BROSELEY FIRES LTD

MODEL: EVOLUTION 5

USE: DOMESTIC SPACE HEATING

MANUFACTURER: **BROSELEY FIRES LTD**
KNIGHTS WAY, BATTLEFIELD ENT PARK.
SHREWSBURY. SY1 3AB ph: +44 (0)1743 461444

NOTIFIED BODY: **GASTEC** **GASTEC AT CRE LTD**
0558 Stoke Orchard, Cheltenham
Gloucestershire
GL52 7RZ

The following harmonised standards and Technical specifications have been met and comply with good engineering practice and safety matters in force within the EEC

All CE standards or other documents Initial Type Test Reports GASTEC 6679-1

EN 13240 CE MARKING INFORMATION - See Instructions

Particular/Smoke Conditions Exempt

As the Manufacturer's authorised representative established within the EEC, Broseley Fires Ltd Declare sole responsibility that the product for mentioned follows the provisions of the directives above.

09/01/2012 Shrewsbury UK
Place and date of issue

JOHN REEVES
Managing Director



Annual Service Record

1ST YEAR SERVICE completion date:

SERVICE ENGINEER: _____ REG. No. _____
 COMPANY NAME: _____
 COMPANY ADDRESS: _____

 _____ POSTCODE: _____
 CONTACT NUMBER _____

2ND YEAR SERVICE completion date:

SERVICE ENGINEER: _____ REG. No. _____
 COMPANY NAME: _____
 COMPANY ADDRESS: _____

 _____ POSTCODE: _____

3RD YEAR SERVICE completion date:

SERVICE ENGINEER: _____ REG. No. _____
 COMPANY NAME: _____
 COMPANY ADDRESS: _____

 _____ POSTCODE: _____

4TH YEAR SERVICE completion date:

SERVICE ENGINEER: _____ REG. No. _____
 COMPANY NAME: _____
 COMPANY ADDRESS: _____

 _____ POSTCODE: _____

5TH YEAR SERVICE completion date:

SERVICE ENGINEER: _____ REG. No. _____
 COMPANY NAME: _____
 COMPANY ADDRESS: _____

 _____ POSTCODE: _____

6TH YEAR SERVICE completion date:

SERVICE ENGINEER: _____ REG. No. _____
 COMPANY NAME: _____
 COMPANY ADDRESS: _____

 _____ POSTCODE: _____



Warranty

This appliance must be installed and commissioned by a fully qualified, registered engineer. A "Declaration of completion Certificate" must be obtained for the installation and retained by the end user. Failure to comply with these requirements may void your warranty.

You, as the end user, have a contract by law with the supplier / dealer from whom you purchased the product. That dealer then has the same contract with the manufacturer or wholesaler and these have a contract with their suppliers.

ALL CLAIMS MUST FOLLOW THIS PROCEDURE.

Thank you for choosing a Product from **Broseley Fires Ltd.** This warranty gives you specific legal rights. The statutory rights of the consumer are not affected by the warranty, or the consumers' rights against the dealer arising from their sales / purchase contract.

The manufacturers' warranty:

Your Product will be free from defective parts, material, and workmanship at the time of its original purchase for a period of five (5) years. This Warranty will become active as of one month from the date of delivery.

This warranty does not cover any failure of the unit due to normal wear and tear, misuse, abuse, accident, illegal modification, illegal installation or repair, damage resulting from improper use or failure to maintain the product. Variations in color and texture are a natural characteristic of cast iron products. Colour changes may result from exposure to light and other elements which are a part of the aging process. These material variations and changes are not covered by this warranty. If during the warranty period, this Product fails to operate under normal use and service, due to defects in material and / or workmanship, Broseley Fires will either repair or replace the product. The repaired or replaced product shall be warranted for the remaining period of the original warranty + the time taken to days from the date of repair, whichever is longer.

Repair or replacement may involve the use of functionally equivalent reconditioned units. Replaced parts or components will become the property of Broseley Fires.

Should you wish to claim under the warranty, please contact the supplier / dealer from whom you purchased the appliance. Do not claim directly to Broseley Fires, as they are unable to process any direct claim from an end user.

Product design and any specifications are subject to change without notice. This is due to our continuous product development and improvement. The buyer will not be entitled to request free upgrades to the new design or compensation for previously purchased products or any products on order.

- This Warranty covers all Broseley Fires costs within the Warranty period.

If the appliance remains uninstalled for a period greater than six months from date of delivery the Warranty will become active six months from the date of original invoice to the distributor.

IN NO EVENT SHALL BROSELEY FIRES BE LIABLE FOR INCIDENTAL OR CONCEQUENTIAL DAMAGES OF ANY NATURE WHATSOEVER, INCLUDING BUT NOT LIMITED TO LOST PROFITS OR COMMERCIAL LOSS, TO THE FULL EXTENT THOSE DAMAGES CAN BE DISCLAIMED BY LAW. (if applicable)

NON - COVERAGE OF THE GUARANTEE

The consumable items within the product are not covered by the warranty, nor is the glass
If the end-user's claim should not be covered by this guarantee, the end-user shall be liable for costs incurred by Broseley Fires such as callout and inspection costs for examination of the product, transportation costs of the product as well as any other relevant costs.

If, after having been informed about the non-coverage of the guarantee, the end-user wants to have the repairs done, the end-user shall additionally pay for any spare parts used and for the labour and transportation costs incurred. If repairs are carried out under this guarantee, the remaining guarantee period for the product shall be extended by the period of time that has elapsed since the complaint was officially logged with Broseley Fires until the repairs have been completed

A COPY OF OUR FULL TERMS AND CONDITIONS IS AVAILABLE ON REQUEST.

** End-user means the natural or legal person who owns the product and who has not acquired it with a view to reselling or installing it in the course of business