



# Midas Plus

**INSET LIVE FUEL-EFFECT GAS FIRES**

**Installation, Maintenance & User Instructions.**

**Hand these instructions to the user after installation.**

**Model No's NSPC\*\*MN, NSPC\*\*TN & NSPC\*\*RN are for use on Natural Gas (G20) at a supply pressure of 20 mbar in G.B. / I.E.**

**\*\* denotes variant of trim / fascia where applicable**

# CONTENTS PAGE

<b>Section 1</b>	<b>Information and Requirements</b>	<b>PAGE</b>
1.0	Appliance Information	3-4
1.1	Conditions of Installation	5
1.2	Flue and chimney suitability	5
1.3	Fireplace / surround suitability	6
1.4	Shelf position	6
1.5	Chimney inspection	6-7
1.6	Fire place opening / catchment space	7-8
1.7	Fitting to metal flue boxes	8
1.8	Hearths	9
1.9	Pre-cast flue installations	9
1.10	Spillage monitoring system	9
<b>Section 2</b>	<b>Installation of Fire</b>	
2.1	Unpacking the fire	10
2.2	Installing the fire box	10-15
2.3	Gas tightness and inlet pressure (manual control models)	16
2.4	Gas tightness and inlet pressure (remote / electronic fire control models)	16
<b>Section 3</b>	<b>Assembling Fuel Bed and Commissioning</b>	
3.1	Assembling the ceramics and fuel bed (coal variants)	17-19
3.2	Assembling the ceramics and fuel bed (pebble variants)	20-21
3.3	Fixing the Infra-red eye in position	22
3.4	Connecting the battery pack	23
3.5	Fitting the trim	23
3.6	Fitting the fender	23
3.7	Lighting the appliance (manual control models)	24
3.8	Lighting the appliance (electronic fire control models)	25
3.9	Lighting the appliance (remote control models)	26
3.10	Checking for clearance of combustion products	27-28
<b>Section 4</b>	<b>Maintenance</b>	
4.1	Removal of the burner assembly (manual control models)	29
4.2	Removal of the piezo igniter (manual control models)	29
4.3	Removal of the control tap (manual control models)	30
4.4	Removal of the pilot assembly (manual control models)	30
4.5	Removal of the burner assembly (remote & electronic fire control models)	31
4.6	Removal of the valve (remote & electronic fire control models)	31
4.7	Removal of the oxy-pilot assembly (remote & electronic fire control models)	31-32
4.8	Replacing the batteries (remote & electronic fire control models)	32
4.9	Removal of the trim switch (electronic fire control models)	32
	Part Shortlist / Fret Information	33
<b>Section 5</b>	<b>User Instruction Section</b>	
5.1	Conditions of Installation & about your new fire	34-35
5.2	Operating the fire (manual control models)	36
5.3	Operating the fire (electronic fire control models)	37
5.4	Operating the fire (remote control models)	38-39
5.6	Remote handset / EFC trim switch malfunction	40
5.7	Replacing the batteries in remote control models	40
5.8	Replacing the batteries electronic fire control models	40
5.9	Spillage monitoring system	41
5.10	Cleaning instructions	41
5.11	Re-assembling the ceramics and fuel beds	42-47

## SECTION 1 INFORMATION AND REQUIREMENTS

### 1.0 APPLIANCE INFORMATION

Model	NSPC**MN (MC)	NSPC**RN (RC) NSPC**TN (EFC)
Gas Type	G20	G20
Main injectors (1 off)	Size 440	Size 380
Burner Type / Pilot Type	Aeromatic Self Vitiating Tubular Burner	SIT Oxystop YA OP 9055
Maximum gross heat Input :	6.5 kW	6.3 kW
Minimum gross heat Input :	2.2 kW	2.2 kW
Cold Pressure :	20.0 +/-1.0 mbar (all models)	
Ignition :	Push Button Piezo (MC models) 9V Battery Generator (RC & EFC models)	
Electrode Spark Gap	4.5mm	4.0mm
Weight	14.0kg	15.0kg

This appliance is manufactured by:-

BFM Europe Ltd,  
Trentham Lakes,  
Stoke-on-Trent,  
ST4 4TJ.

### **Fire box Dimensions (Midas Plus Models)**

Width :	(with trim, no spacer)	498mm
Height :	(with trim, no spacer)	600mm
Depth :	(overall-without fender)	125mm

Gas Connection            8mm Compression            (Supplied with fire)

### **Efficiency Declaration**

The efficiency of this appliance has been measured as specified in BS 7977-1 : 2009 and the result is 63%. The gross calorific value of the fuel has been used for this efficiency calculation. The test data from which it has been calculated has been certified by BSI. The efficiency value may be used in the UK Governments Standard Assessment Procedure (SAP) for energy rating of dwellings.

# INSTALLATION REQUIREMENTS

## 1.1 CONDITIONS OF INSTALLATION

It is the law that all gas appliances are installed only by a GAS SAFE Registered Installer, in accordance with these installation instructions and the Gas Safety (Installation and Use) Regulations 1998 as amended. Failure to install appliances correctly could lead to prosecution. It is in your own interest and that of safety to comply with the law.

The installation must also be in accordance with all relevant parts of the Local and National Building Regulations where appropriate, the Building Regulations (Scotland Consolidation) issued by the Scottish Development Department, and all applicable requirements of the following codes of practice :-

1. BS 5871 Part 2 Installation of Inset Live Fuel Effect Gas Fires
2. BS 6891 Installation of Gas Pipework
3. BS 5440 Parts 1 & 2 Installation of Flues and Ventilation
4. BS 1251 Open fire place components
5. BS 715 / BS EN 1856-2 Metal flue pipes for gas appliances
6. BS 6461 Part 1 Installation of Chimneys and flues
7. B.S. E.N. 1858 Chimneys Components & Concrete Flue Blocks
8. IS 813 : 1996 Domestic Gas Installation (Republic of Ireland)

**No purpose made additional ventilation is normally required for this appliance, when installed in G.B. When installing in I.E. please consult document I.S. 813 : 1996 Domestic Gas Installation, which is issued by the National Standards Authority of Ireland. If installing in Northern Ireland, please consult local building regulations. Any purpose made ventilation must be checked periodically to ensure that it is free from obstruction.**

## 1.2 FLUE AND CHIMNEY SUITABILITY

This appliance is designed for use with conventional brick built or lined chimneys and fabricated flues and metal flue boxes conforming to BS 715 / BS EN 1856-2. All flues must conform to the following minimum dimensions.

<b>Minimum diameter of circular flues</b>	<b>125 mm (without flue restrictor fitted)</b>
<b>Minimum effective height of all flue types</b>	<b>3 metres</b>

**When fitting to conventional chimneys or 175mm flues it may be desirable to fit the flue restrictor baffle (supplied) to reduce the flue flow and increase the efficiency of the fire. Safe clearance of products must always be checked by carrying out a smoke match test as described.**

### 1.3 FIREPLACE / SURROUND SUITABILITY

The fire must only be installed on a hearth it **must not be installed directly onto carpet or other combustible floor materials.**

The fire is suitable for fitting to non-combustible fire place surrounds and proprietary fire place surrounds with a temperature rating of at least 150<sup>o</sup>c. (Class "O")

**If a heating appliance is fitted directly against a wall without the use of a fire surround or fire place all combustible material must be removed from behind the trim. Soft wall coverings such as blown vinyl, wall paper etc. could be affected by the rising hot air and scorching and/or discoloration may result. Due consideration should be made to this when installing or decorating.**

### 1.4 SHELF POSITION

The fire may be fitted below a combustible shelf providing there is a minimum distance of 200mm above the top of the fire and the shelf does not project more than 150mm. If the shelf overhangs more than 150mm the distance between the fire and the shelf must be increased by 15mm for every 25mm of additional overhang over 150mm.

### 1.5 FLUE / CHIMNEY INSPECTION

Before commencing installation, a flue or chimney should be inspected to ensure that all the following conditions are satisfied.

1. Check that the chimney / flue only serves one fire place and is clear of any obstruction. Any dampers or register plates must be removed or locked in the open position.
2. Brick/stone built chimneys or any chimney or flue which has been used for an appliance burning fuel other than gas must be thoroughly swept. The base of the chimney / flue must also be thoroughly cleared of debris etc.
3. Any under-floor air supply to the fire place must be completely sealed off.
4. Ensure that the inside of the chimney / flue is in good condition along it's length and check that there is no leakage of smoke through the structure of the chimney during and after the smoke pellet test.
5. **Using a smoke pellet, check that there is an up-draught in the chimney / flue and that the smoke can be seen issuing from the terminal / chimney pot outside. There must be no leakage of smoke through the structure of the chimney during or after the smoke pellet test and it is important to check inside upstairs rooms adjacent to the chimney / flue.**

Check the chimney pot / terminal and general condition of the brickwork or masonry. If the chimney or flue is in poor condition or if there is no up-draught do not proceed with the installation. If there is a history of down-draught conditions with the chimney / flue, a tested and certificated flue terminal or cowl suitable for the relevant flue type should be considered.

6. **A spillage test must always be carried out during commissioning of the appliance.**

### 1.6 FIRE PLACE OPENING AND CHIMNEY CATCHMENT SPACE

The front opening of the fire place must be between 330 and 440mm wide, and between 550 and 575mm high. If the opening exceeds these dimensions then a surround must be constructed from suitable non-combustible material to produce a correct size opening. Any surround must be suitably sealed to the fire place to prevent leakage. See below in figure 1.

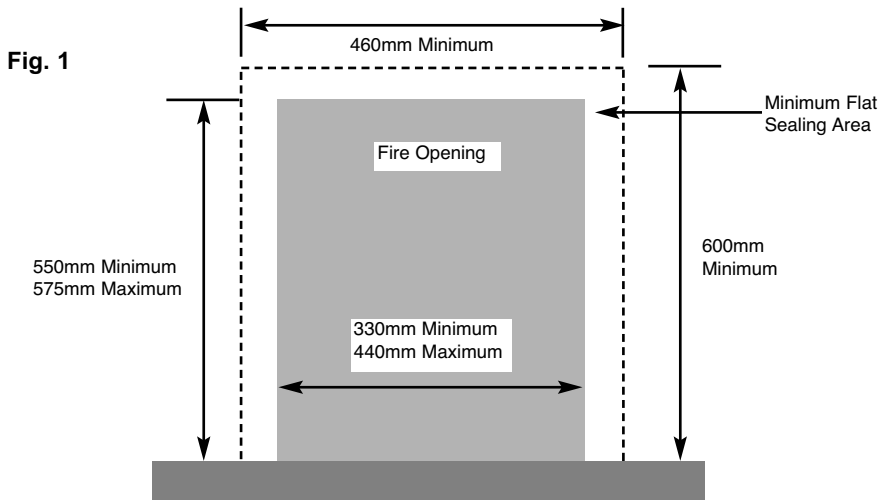

When installing into a brick built chimney, you must ensure that there is sufficient depth to accommodate any debris which may fall from the chimney. This depth must be sufficient to accommodate 12 litres of volumetric space.

**Table A - Installation Depth Requirements for a Verine Midas Plus being installed into a brick built chimney, requiring 12.0 litres of debris collection volume (figure 2)**

Opening Width (mm)	Minimum Depth Required (mm)
330 (minimum opening width)	152
340	149
350	146
360	144
370	142
380	139
390	137
400	135
410	135
420	135
430	135
440 (maximum opening width)	135

For example, if the appliance was to be fitted into a 400mm wide opening, the depth required would be 135mm. See fig. 2 below for explanatory diagram.

**Fig. 2**

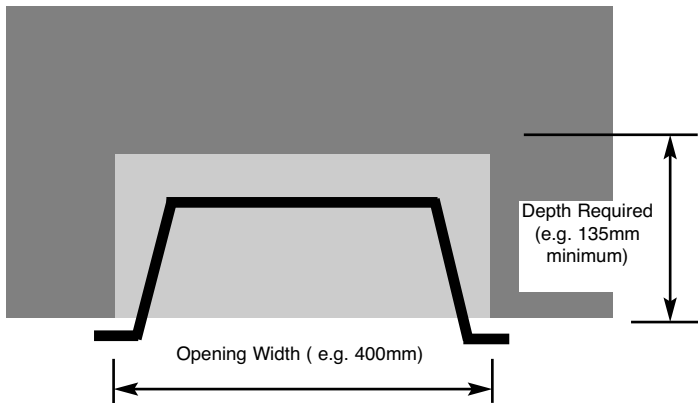

**1.7 FITTING TO PRE-FABRICATED TWIN WALL METAL FLUE BOXES**

The appliance may be fitted to twin wall metal flue boxes conforming to the constructional requirements of BS 715 / BS EN 1856-2, (for example the Selkirk LFE 175 box). The box must have a minimum flue diameter of 125mm internal and minimum internal dimensions of 185mm deep by 580mm high by 400mm wide. There are no maximum dimensional requirements for the box. The top face of the box must be insulated with a minimum thickness of 50mm of non-combustible mineral wool insulation or similar material. The flue box must stand on a non-combustible base of minimum thickness 12mm.



## 1.8 HEARTH

This appliance must only be installed on to a concrete or non-combustible hearth. The hearth material must be a minimum thickness of 13mm with the top surface at least 50mm above the floor. The hearth must be fitted symmetrically about the fire opening and have a minimum width of 760mm and a minimum projection of 300mm forwards from the fire opening. EFC models required an increased hearth projection of 320mm forwards of the fireplace opening.

## 1.9 FITTING TO PRE-CAST FLUE INSTALLATIONS

**When installing this appliance into pre-cast flues, always ensure that the spigot restrictor baffle has been removed. This is held in place on the spigot by 2 screws. To install the fire box in to pre-cast flue starter blocks, there must be at least 135mm from the mounting face of the fire to the rear of the pre-cast flue starter block** to allow sufficient space for debris collection. If this dimension is less than 135mm then a fire surround with a deeper rebate to increase the depth to at least 135mm from the mounting face of the fire. It is important to consider this depth when choosing a fire surround as the thickness of the fire surround must be sufficient to give a total depth of **at least 135 mm to the rear of the starter block**, otherwise there will be insufficient depth. To increase this depth the fire surround may be packed away from the wall using suitable non-combustible board, providing the installation is correctly sealed. If in doubt about the suitability of the fire contact BFM Europe Ltd. for advice before proceeding. It is important to ensure that the pre-cast flue is in good condition and is free from extruded mortar or sealant from between the flue blocks.

**This appliance has been tested for use in a pre-cast flue block complying with BS EN 1858. In accordance with BS EN 1858, pre-cast flues built with directly plastered faces (front or rear) are not correctly installed as to ensure proper operation with any type of gas fire. In some instances of this flue construction, temperature cracking of surface plaster may occur through no fault of the appliance. An air gap or some form of insulation material should be installed to prevent normal flue temperatures from damaging wall surfaces.**

### 1.10 SPILLAGE MONITORING SYSTEM

This appliance is fitted with an atmosphere sensing spillage monitoring system in the form of an oxygen sensing pilot. This is designed to shut the fire off in the event of a partial or complete blockage of the flue causing a build up of combustion products in the room in which the fire is operated. **The following are important warnings relating to this spillage monitoring system :-**

- 1) The spillage monitoring system must not be adjusted by the installer.
- 2) The spillage monitoring system must not be put out of operation.
- 3) When the spillage monitoring system is exchanged only a complete original manufacturers part may be fitted.

## SECTION 2 INSTALLATION OF FIRE

### 2.1 UNPACKING THE FIRE

Carefully lift the fire out of the carton. Remove the loose item packaging carefully from the front of the appliance. Check the contents as listed :-

#### Packing check list - manual control models

- 1 off Fire box / burner assembly
- 1 off Boxed ceramic base and 22 synthetic coals (2 small, 16 medium, 4 large)
- 1 off Loose items bag inc guarantee card and cable fixing kit
- 1 off Installation / user book (combined)
  
- 1 off Pebble set (if ordered as an optional extra) pack 2 of 2

#### Packing check list - remote control models

- 1 off Fire box / burner assembly
- 1 off Boxed ceramic base and 22 synthetic coals (2 small, 16 medium, 4 large)
- 1 off Loose items bag inc guarantee card, battery holder & cable fixing kit
- 1 off Installation / user book (combined)
- 1 off 9V battery
- 6 off 1.5V batteries
- 1 off Handset
  
- 1 off Pebble set (if ordered as an optional extra) pack 2 of 2

#### Packing check list - easy flame control models

- 1 off Fire box / burner assembly
- 1 off Boxed ceramic base and 22 synthetic coals (2 small, 16 medium, 4 large)
- 1 off Loose items bag inc guarantee card, battery holder & cable fixing kit
- 1 off Installation / user book (combined)
- 6 off 1.5V batteries
  
- 1 off Pebble set (if ordered as an optional extra) pack 2 of 2

### 2.2 INSTALLING THE FIRE BOX

Establish which type of flue you are intending to install the fire in to :-

**225 x 225mm (9 inch x 9 inch) brick built chimneys**

**175mm (7 inch) diameter lined brick or stone flue, insulated pre-fabricated**

**metal flue box to BS 715 / BS EN 1856-2 or Pre-Cast Flue to BS EN 1858**

**When installing into 125mm (5 inch) diameter lined brick or stone flue, or insulated pre-fabricated metal flue box to B.S. 715 and pre-cast flues the restrictor baffle must not be fitted.**

**A spillage test must always be carried out to check satisfactory clearance of flue products, regardless of the type of flue the appliance is being fitted to.**

**For manual control models proceed as follows :-**

- a) Remove the two screws at the bottom of the control panel. See fig. 3 below

**Fig. 3**

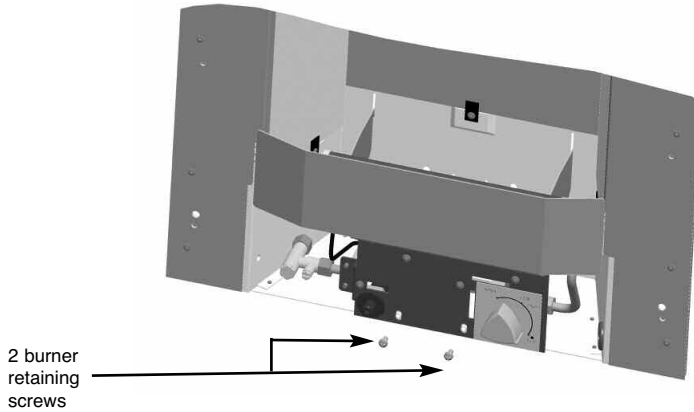

- b) The base of the burner unit can now be lifted, lift the two retaining tabs on the burner brackets from the back of the firebox, allowing the burner to be removed. See fig. 4 below

**Fig. 4**

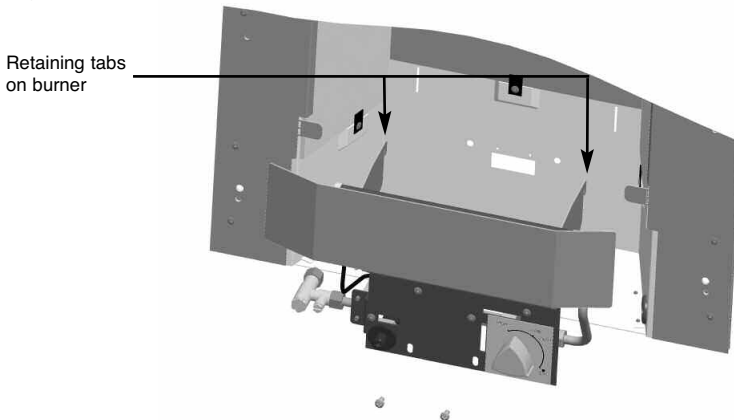

**For remote and electronic fire control models proceed as follows :-**

- d) Remove the two screws at the bottom of the control panel, remove the screw which retains the gas inlet elbow retaining bracket. See fig. 5 below.

**Fig. 5**

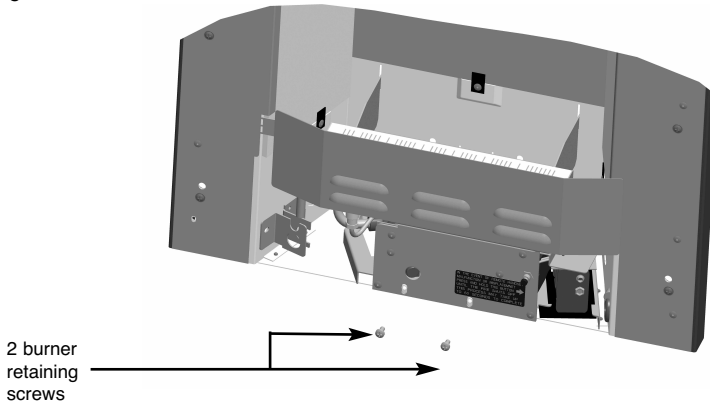

- e) The base of the burner unit can now be lifted, lift the two retaining tabs on the burner brackets from the back of the firebox, allowing the burner to be removed. See fig. 6 below

**Fig. 6**

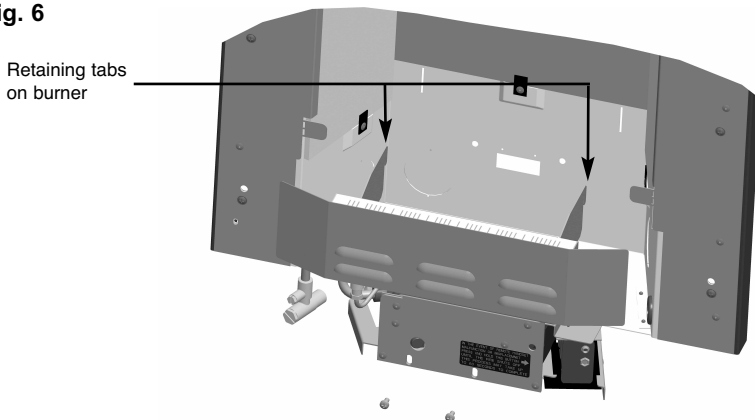

- f) Ensure that the hearth is protected from damage and carefully lift the fire box into the fire opening, then slide it back into position. Check that the fire box flange fits flush to the sealing face of the fire surround or wall with no gaps present.

- g) Whilst the fire box is still in position, decide which side the gas supply is to enter the fire from. If concealed pipe work is required plan the pipe run to enter the fire box through one of the openings in the sides or rear of the fire box below the fuelbed support panel and connect to the isolating / inlet elbow. The gas connection to the appliance should be made to the isolating / inlet elbow using 8mm rigid tubing. There must be no soldered joints within the firebox. See fig. 7 & 8 below for suggested concealed pipe layouts.

**Fig. 7 - R/H/S Gas Supply Route**

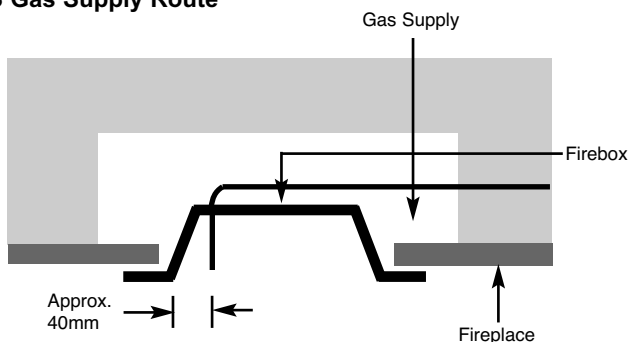

**Fig. 8 - L/H/S Gas Supply Routes**

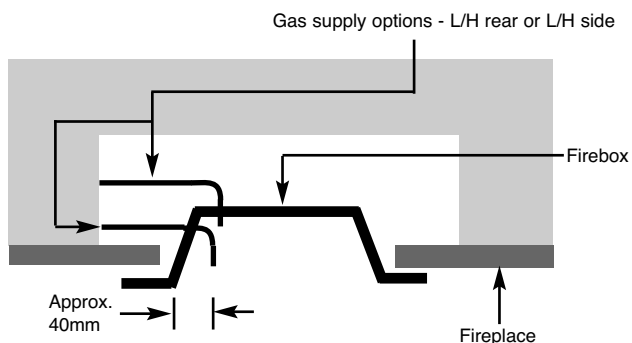

**Note : Before breaking into the gas supply a tightness test should be carried out to establish that the existing pipework is sound.**

Carefully withdraw the fire box from the opening to enable the gas supply and fire fixing to be completed.

**IMPORTANT** : THE 45MM GROMMET SUPPLIED IN THE LOOSE ITEMS MUST BE USED TO SEAL THE GAS INLET POINT UTILISED ON THE FIREBOX. FAILURE TO SEAL THIS INLET POINT COULD RESULT IN FLAME REVERSAL AND DAMAGE TO THE CONTROLS ON THE FIRE. BFM EUROPE ACCEPT NO RESPONSIBILITY FOR DAMAGE TO THE FIRE AS A RESULT OF FAILURE TO FOLLOW THIS REQUIREMENT.

The preferred method of fixing which is suitable for almost all situations is the cable fixing method which is described in the following section in detail.

To fit using the **preferred** cable method proceed as follows-

- h) Mark out and drill 4 off No 14 (6mm) holes in the back face of the fire opening in the positions shown below in figure 9

**Fig. 9**

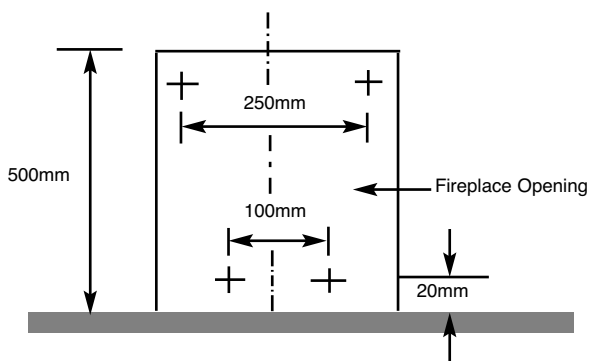

Fit the wallplugs provided and screw the fixing eyes securely into the rear of the fire opening.

- i) Uncoil the two fire fixing cables and thread one end of each of the cables through one of the two holes on each side of the flue outlet shroud.
- j) Position the fire carefully on the (protected) surface of the hearth and reach into the fire opening. Thread each of the cables vertically downwards through the pair of fixing eyes on the same side of the fire. Thread the free end of the cables through the corresponding circular hole on each side of the lower rear of the fire. Carefully slide the fire box back into the fire opening and pull both cables tight.
- k) Thread a tensioning screw over each of the cables and ensure that the tensioning nut is screwed fully up against the hexagon shoulder of the tensioning screw (this provides maximum travel for the tensioning nut).
- l) Fit a screwed nipple on to each of the cables and pull hand tight up against the tensioning screw, then secure each nipple with a flat bladed screwdriver. See figure 10 overpage.

Fig. 10

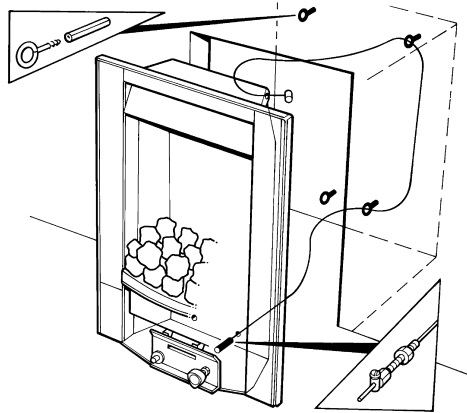

- m) Evenly tighten the tensioning nuts to tension both cables and pull the fire snugly against the wall. Do not overtighten, it is only necessary to pull the seal up against the sealing face of the wall, it does not need to be compressed. Check that there are no gaps behind the seal.
- n) With the fire securely in place, if a concealed gas connection has been made through either of the access holes in the sides of the fire, the holes should be closed around the pipe to prevent leakage of air through the gap around the pipe.
- o) Refit the burner. Fit the two retaining screws and check that the burner is correctly locked into position.
- p) **Before making the final gas connection, thoroughly purge the gas supply pipework to remove all foreign matter, otherwise serious damage may be caused to the gas control valve on the fire.**

### **2.3 GAS TIGHTNESS AND INLET PRESSURE (MANUAL CONTROL MODELS)**

- a) Remove the pressure test point screw from the inlet elbow and fit a manometer.
- b) Turn on the main gas supply and carry out a gas tightness test.
- c) Depress the control knob and turn anti-clockwise to the position marked ignition / low. Hold in the control knob for a few seconds to purge the pipe work then press the igniter button. The burner should light, continue to hold the control knob for a few seconds then turn to the full-on position.
- d) Check that the gas pressure is **20.0 mbar (+/- 1.0mbar) 8.0 in w.g.(+/- 0.4 in w.g.)**
- e) Turn off the fire, remove the manometer and refit the pressure test point screw. Check the pressure test point screw for gas tightness with the appliance turned on using a suitable leak detection fluid or detector.

### **2.4 GAS TIGHTNESS AND INLET PRESSURE - REMOTE CONTROL OR EASY FLAME CONTROL MODELS**

- a) Remove the pressure test point screw from the inlet elbow and fit a manometer.
- b) Turn on the main gas supply and carry out a gas tightness test.
- c) Light the fire, see page 25 / 26 for full details of the operating method for the fire.
- d) Check that the gas pressure is **20.0 mbar (+/- 1.0mbar) 8.0 in w.g.(+/- 0.4 in w.g.)**
- e) Turn off the fire, remove the manometer and refit the pressure test point screw. Check the pressure test point screw for gas tightness with the appliance turned on using a suitable leak detection fluid or detector.



## SECTION 3 ASSEMBLING FUEL BED AND COMMISSIONING

### 3.1 ASSEMBLING THE CERAMICS AND FUEL BED - COAL MODELS

- a) Place the fuelbed base centrally on to the fuelbed support and push fully backwards to the rear face of the fibre boards **Make sure that the fuelbed base is located centrally in the fire box, behind the retaining tabs as shown below.** Fit 7 off small coals along the front edge of the fuelbed base as shown below in figure 11.

Fig. 11

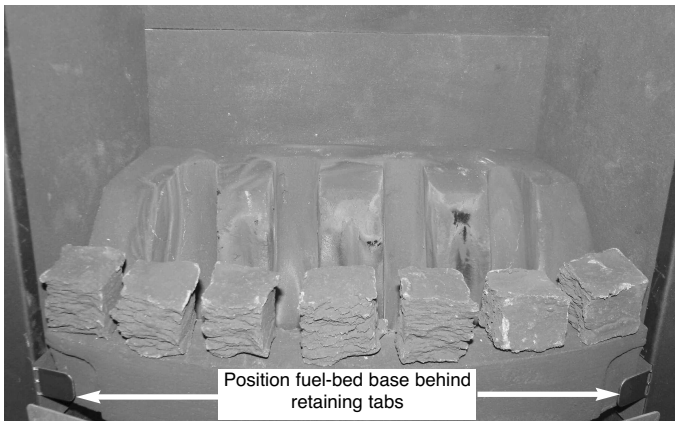

- b) Select 4 off large coals and arrange behind the front row of coals, ensuring that flame paths as indicated below are not interrupted, see figure 12 below.

Fig. 12

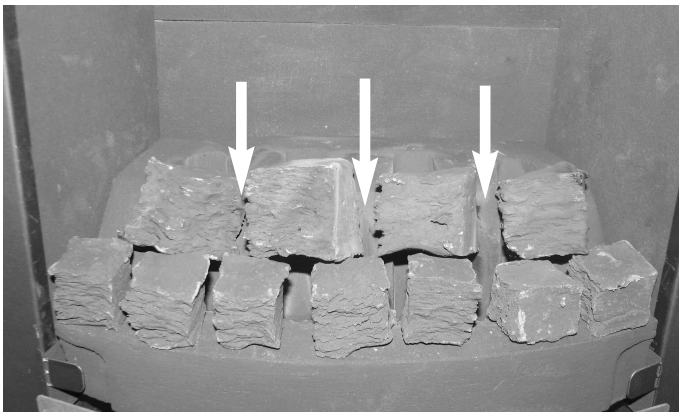

- c) Select 3 off large coals and arrange along the rear of the fuelbed, using the ribs in the rear of the fuelbed as a guide for placement, see figure 13 below.

**Fig. 13**



- d) Select 2 off small coals and arrange at the left hand and right hand end of the third row of coals, see figure 14 below.

**Fig. 14**



- e) Select 6 off small coals and arrange along the rear of the fuel-bed as shown below in figure 15.

**Fig. 15**



**The exact position and fit of the coals may be finely adjusted to give the best appearance.**

**Warning : Use only the coal set supplied with the fire. When replacing the coals remove the old coals and discard them. Fit a complete set of coals of the correct type. Do not fit additional coals or any coals other than a genuine replacement set.**

This appliance uses fuel effect pieces containing Refractory Ceramic Fibres (R.C.F.), which are man-made vitreous silicate fibres. Excessive exposure to these materials may cause temporary irritation to eyes, skin and respiratory tract. Consequently, it makes sense to take care when handling these articles to ensure that the release of dust is kept to a minimum. To ensure that the release of fibres from these R.C.F. articles is kept to a minimum, during installation & servicing we recommend that you use a HEPA filtered vacuum to remove any dust and soot accumulated in and around the fire, before and after working on the fire. When replacing these articles we recommend that the replaced items are not broken up, but are sealed within a heavy duty polythene bag, clearly labelled as "RCF waste". This is not classified as "hazardous waste" and may be disposed of at a tipping site licensed for the disposal of industrial waste. Protective clothing is not required when handling these articles, but we do recommend you follow the normal hygiene rules of not smoking, eating or drinking in the work area, and always wash your hands before eating or drinking. This appliance does not contain any component manufactured from asbestos or asbestos related products.

### 3.2 ASSEMBLING THE CERAMICS AND FUEL BED - PEBBLE MODELS

- a) Place the fuelbed base centrally on to the fuelbed support and push fully backwards to the rear face of the fibre boards **Make sure that the fuelbed base is located centrally in the fire box, behind the retaining tabs** as shown below in figure 16.

Fig. 16

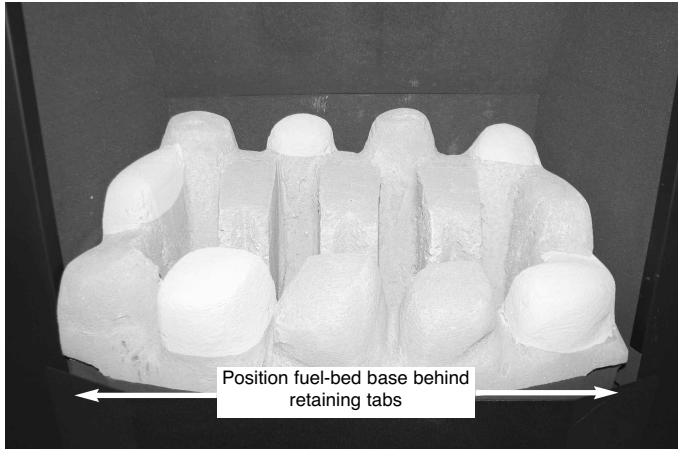

- b) Position the front row of four large loose pebbles along behind the first row of pebbles, ensuring that the flame paths as indicated are not interrupted. See figure 17 below.

Fig. 17

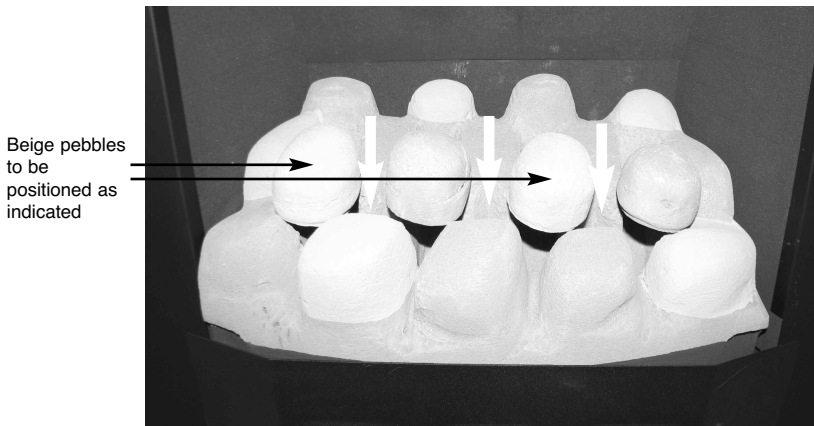

- c) Fit the three small pebbles onto the ribs in the fuelbed as shown below, ensuring that the rear flame paths as indicated are not interrupted. See figure 18 below.

**Fig. 18**

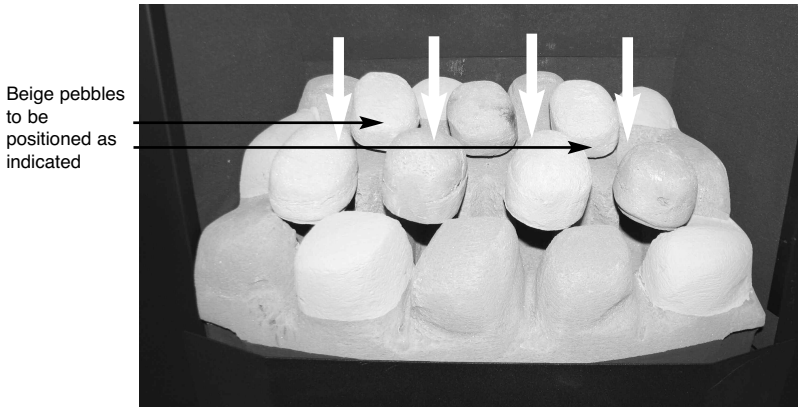

The exact position and fit of the pebbles may be finely adjusted to give the best appearance.

**Warning :** Use only the pebble set supplied with the fire. When replacing the pebbles remove the old pebbles and discard them. Fit a complete set of pebbles of the correct type. Do not fit additional pebbles or any pebbles other than a genuine replacement set.

This appliance uses fuel effect pieces containing Refractory Ceramic Fibres (R.C.F.), which are man-made vitreous silicate fibres. Excessive exposure to these materials may cause temporary irritation to eyes, skin and respiratory tract. Consequently, it makes sense to take care when handling these articles to ensure that the release of dust is kept to a minimum. To ensure that the release of fibres from these R.C.F. articles is kept to a minimum, during installation & servicing we recommend that you use a HEPA filtered vacuum to remove any dust and soot accumulated in and around the fire, before and after working on the fire. When replacing these articles we recommend that the replaced items are not broken up, but are sealed within a heavy duty polythene bag, clearly labelled as "RCF waste". This is not classified as "hazardous waste" and may be disposed of at a tipping site licensed for the disposal of industrial waste. Protective clothing is not required when handling these articles, but we do recommend you follow the normal hygiene rules of not smoking, eating or drinking in the work area, and always wash your hands before eating or drinking. This appliance does not contain any component manufactured from asbestos or asbestos related products.

### 3.3 FIXING THE INFRARED SENSOR IN POSITION (RC MODELS ONLY)

- a) Due to the different fascia's that can be supplied with these fires, the infrared sensor is supplied from the factory attached to a self adhesive pad. This pad can therefore be attached to the hearth in a position to suit the form of the fret assembly that is chosen with the product. figure 19 below shows the self adhesive pad and infrared eye attached to the flying lead, as supplied from the factory.

**Fig. 19**

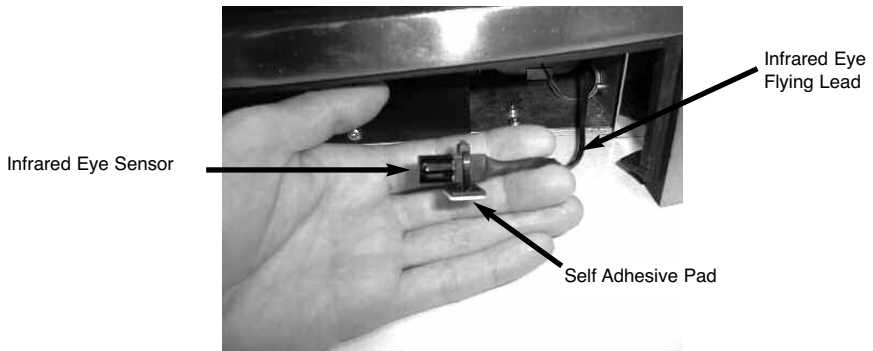

- b) Remove the backing paper from the self adhesive pad and position the infrared eye in the air channels in the ashpan cover, so that the infrared eye is flush with the front edge of the ashpan cover, as shown below in figure 20. Check the operation of the handset, as detailed in section 3.9 and adjust the position of the infrared eye if necessary.

**Fig. 20**

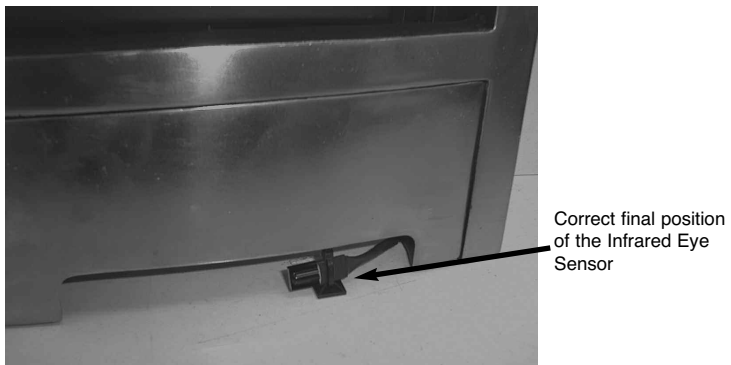

### 3.4 CONNECTING THE BATTERY PACK (RC & EFC MODELS)

- a) To prevent un-necessary battery drain, the battery pack that is used to provide the remote control function for this product is disconnected at the factory. Prior to attempting to light the product, can the installer please ensure that the battery pack is re-connected as shown in section b), c) & d) below.
- b) Locate the battery pack in the support cradle at the bottom R/H side of the firebox / burner assembly.
- c) The wire and connecting plug from the battery pack should then be connected into the supply wire running from the control board. See figure 21 below.

**Fig. 21**

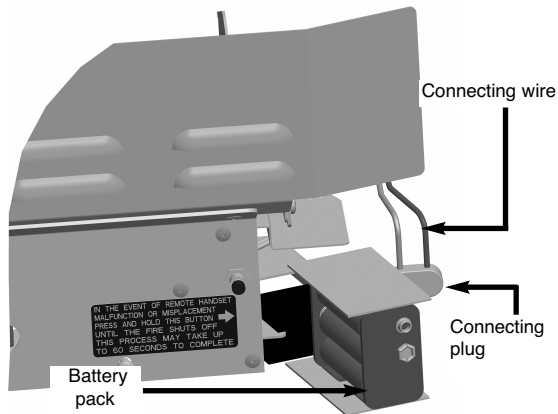

- d) Replace the battery pack into its mounting cradle below the burner.

### 3.5 FITTING THE TRIM

- a) The trim is held in position on the fixing flange by magnets.

### 3.6 FITTING THE FENDER

- a) The fender is placed up to the front of the ceramic front rail on all models. Position the ashpan under the fender and centralise.

### 3.7 LIGHTING THE APPLIANCE - MANUAL CONTROL MODELS

- a) Turn on the gas isolation tap.
- b) Depress the control knob and turn anti-clockwise to the position marked ignition / low rate. Hold in the control knob for a few seconds to purge the pipe work.
- c) Continue to hold-in the control knob and press the igniter button. If the burner does not light, continue to press the igniter button until ignition occurs. Continue to hold the control knob for a minimum of 20 seconds to allow the thermocouple to heat up, if the burner goes out when the control knob is released, repeat the lighting sequence.
- d) Turn the control knob in the anti-clockwise direction to the high position and the gas rate will increase to high rate (6.5 kW)
- e) Turn the control knob clockwise to the low position and the gas input will be reduced to the minimum setting (2.2 kW)
- f) Slightly depress the control knob and turn to the off position, the burner will now be extinguished.

**WARNING : If the fire goes out for any reason or is turned off and it is necessary to re-light the fire it is important to allow the fire to cool for 3 minutes before attempting to re-light it.**



### 3.8 LIGHTING THE APPLIANCE - ELECTRONIC FIRE CONTROL MODELS.

- a) To light the fire using the electronic fire control, press the ignition button as indicated below in figure 22. The fire will emit a “beep” sound, the buttons can now be released. After a few seconds an audible clicking can be heard and then the fire will light the pilot and then light the main burner. The ignition cycle will take approximately 20 seconds.
- b) To reduce the level of heat input on the fire, press the small flame button on the trim switch. (An audible beep will be heard)
- c) To increase the level of heat input on the fire, press the large flame button on the trim switch. (An audible beep will be heard)
- d) To leave the fire in the standby mode (pilot only running) press the small round button on the trim switch. (An audible beep will be heard)
- e) To switch the appliance off completely, press the Ignition / Off button on the trim switch, the fire will then switch off. (An audible beep will be heard)

Fig. 22

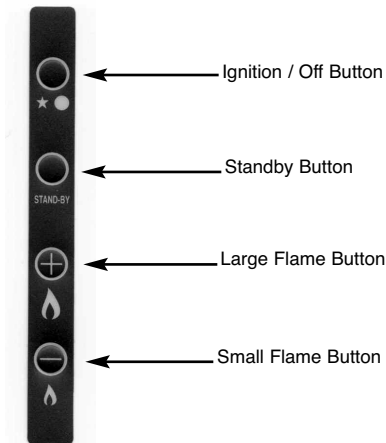

**WHEN TURNING THE FIRE “OFF” PLEASE ENSURE THAT THE PILOT FLAME IS EXTINGUISHED. DO NOT LEAVE THE PILOT FLAME ONLY LIT.**

**WARNING : If the fire goes out for any reason or is turned off and it is necessary to re-light the fire it is important to allow the fire to cool for 3 minutes before attempting to re-light it.**

### 3.9 LIGHTING THE APPLIANCE - REMOTE CONTROL MODELS

- a) The Remote control handset generates an infrared signal, which will be received by the sensor situated at the front right of your fire, behind the ashpan cover. This infrared signal requires direct line of sight from the handset to the sensor on the fire to ensure good operation.
- b) To light the appliance using the handset, point the handset at the fire and press the 2 left hand buttons together. The fire will emit a “beep” sound, the buttons can now be released. After a few seconds an audible clicking can be heard and then the fire will light the pilot and then light the main burner. The ignition cycle will take approximately 20 seconds.
- c) To reduce the level of heat input on the fire, point the handset at the fire and press the small flame button. (An audible beep will be heard)
- d) To increase the level of heat input on the fire, point the handset at the fire and press the large flame button. (An audible beep will be heard)
- e) To leave the fire in the standby mode (pilot only running) press the small round button on the handset.
- f) To switch the appliance off completely, press the large round button on the handset, the fire will then switch off.

**Fig. 23**

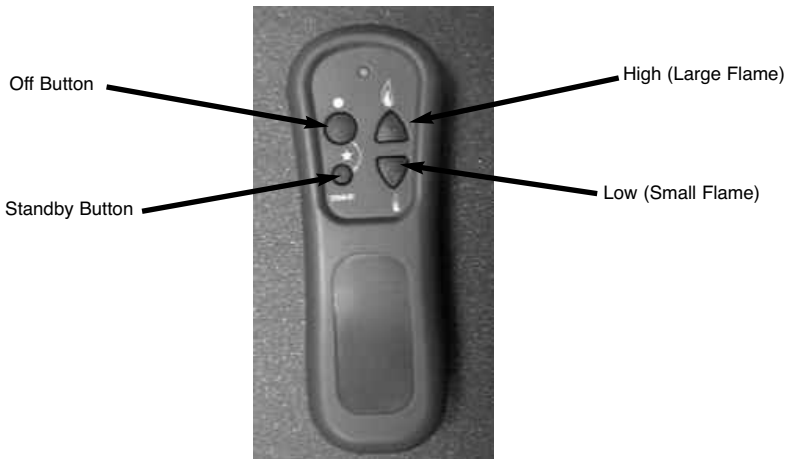

**WARNING : If the fire goes out for any reason or is turned off and it is necessary to re-light the fire it is important to allow the fire to cool for 3 minutes before attempting to re-light it.**

### 3.10 CHECKING FOR CLEARANCE OF COMBUSTION PRODUCTS

- a) Close all doors and windows in the room.
- b) Light the fire and allow to run for approximately 5 minutes on high position.
- c) After approximately 5 minutes hold a smoke match 10mm inside and below the centre of the lower front edge of the top of the fire as shown overpage in figure 25. (It is recommended that a suitable smoke match holder is used when checking for clearance of combustion products). The majority of smoke generated should be drawn back into the flue. If spillage occurs or if in doubt, repeat the test after a further 10 minutes. **If the test indicates that spillage is occurring and the flue restrictor baffle has been fitted, it should be removed and the test repeated after the fire has cooled. See figure 24 below for details of how to remove and re-fit the restrictor baffle.**
- d) If spillage persists with the restrictor baffle removed, the flue is not functioning correctly and a fault exists. If, after investigation the fault cannot be traced and rectified, the fire must be disconnected from the gas supply and expert advice obtained.
- e) If there is an extractor fan fitted any where in the vicinity of the appliance, the spillage test should be repeated with the fan running on maximum and all interconnecting doors open.

**Fig. 24**

Restrictor baffle - Held in position by 2 off self tapping screws on rear spigot of fire. Restrictor baffle can be removed from below the canopy with the firebox installed

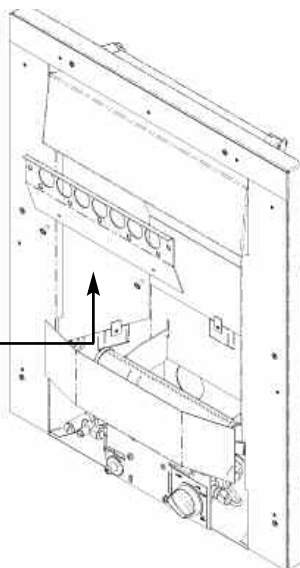

f) After ensuring that the fire is safe to use it should be left in the high position to fully warm up. During this time a slight odour may be noticed, this is due to the “newness” of the fire and will soon disappear.

At this stage any minor adjustments to the coals should be made using suitable long handled tongs and taking care not to damage the coals.

Finally, hand the Installation and Maintenance Instructions and the Users Instructions over to the customer and explain the operation of the fire.

**Fig. 25**

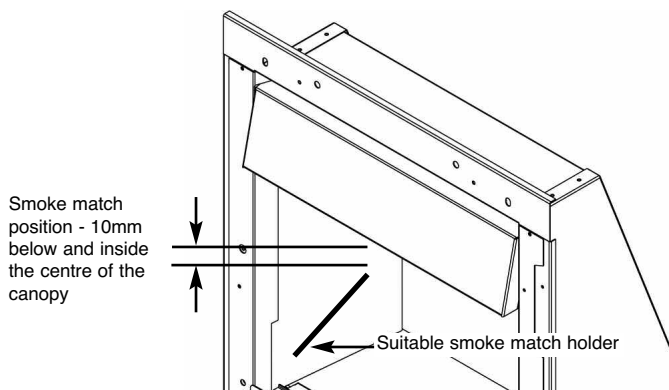

## SECTION 4 MAINTENANCE

### Servicing Notes

Servicing should be carried out annually by a competent person such as a GAS SAFE registered engineer. **This is a condition of the Verine guarantee schemes.**

The service should include visually checking the chimney and fire opening for accumulations of debris and a smoke test to check for a positive up-draught in the chimney. The ODS must also be replaced as a condition of the guarantee.

The condition of the coals / pebbles should be checked and **if necessary the whole set should be replaced with a genuine replacement set.**

The burner assembly is designed to be removed as a complete unit for ease of access. **After any servicing work a gas tightness check must always be carried out.**

### Manual Control Fires – For Diagrams refer to Section 2

#### 4.1 Removing the burner assembly from the fire.

4.1.1 Prepare work area (lay down dust sheets etc.)

4.1.2 Remove the trim. Remove the fret / ash pan cover or contemporary trim out of the way and put them in a safe location. Remove the loose coals or pebbles from the fuel bed. Remove the fuelbed matrix.

4.1.3 Isolate the gas supply and remove the inlet pipe from the appliance inlet elbow. Unscrew and remove the two screws which retain the burner at the base. Lift the burner retaining tabs from the rear of the firebox & remove the burner assembly from the fire.

4.1.4 To refit the burner assembly. Push the retaining tabs into the rear panel of the firebox and secure the burner at the base of the control panel with two screws. Refit the gas supply pipe and carry out a gas tightness test. Refit the coals or pebbles referring to section 3 for the correct layout. The trim and ash pan cover or contemporary trim can now be re-positioned.

#### 4.2 Removing the Piezo Igniter

4.2.1 Remove the burner assembly as in section 4.1

4.2.2 Disconnect the ignition lead from the piezo and unscrew the retaining nut on the rear of the control panel. Withdraw the piezo from the front of the control panel. Re-assemble in reverse order and carry out a gas tightness test.

### **4.3 Removing the Control Tap from the fire.**

- 4.3.1 Remove the burner assembly as in section 4.1.
- 4.3.2 Pull the control knob off the control tap spindle.
- 4.3.3 Loosen and remove the two gas pipe retaining nuts from the control tap and release the ends of the gas pipes from the control tap body. Remove the push in thermocouple from the end of the control tap.
- 4.3.4 Unscrew the control tap locknut from the front of the control panel and remove the control tap.
- 4.3.5 To refit a control tap, reassemble in reverse order noting that the control tap locates with a flat in the control panel. Carry out a gas tightness test after re-assembly.

### **4.4 Removing the Thermocouple**

- 4.4.1 Remove the burner assembly as in section 4.1
- 4.4.2 Remove the push in thermocouple from the end of the control tap and and remove the thermocouple retaining nut from the mounting bracket on the burner assembly.
- 4.4.3 Re-assemble in reverse order and carry out a gas tightness test.

## **Remote & Electronic Fire Control Models – For Diagrams refer to Section 2**

### **4.5 Removing the burner assembly from the fire.**

- 4.5.1 Prepare work area (lay down dust sheets etc.)
- 4.5.2 Lift the fender and ash pan cover of the way and put them in a safe location. Remove the loose coals from the fuel bed, then the fuel-bed matrix. Remove the screw from the inlet elbow retaining bracket and also the two pozi-driv fixing screws which secure the burner to the firebox base. Remove the burner from the fire.
- 4.5.3 Isolate the gas supply and remove the inlet pipe from the appliance inlet elbow. Unscrew and remove the four screws which retain the burner. Remove the HT lead from the Pilot electrode and remove the burner assembly from the fire, ensuring not to pull too tightly on the PCB wiring. Cut the cable tie from the remote infrared eye self adhesive pad, which will be situated on the hearth panel, flush with the front edge of the ashpan cover.
- 4.5.4 To refit the burner assembly. Ensure wiring is fitted correctly to the PCB assembly. Push the retaining tabs into the rear panel of the firebox and secure the burner at the base of the control panel with two screws. Refit the gas supply pipe and carry out a gas tightness test. Refit the coals / pebbles referring to section 3 for the correct layout. On RC models the infrared eye must be cable tied back to the self adhesive pad which will be situated on the hearth panel. The fender and ash pan cover or can now be re-positioned.

### **4.6 Removing the gas valve.**

- 4.6.1 Remove the burner assembly as in section 4.5
- 4.6.2 Remove the thermocouple retaining nut from the valve. Remove the main pipe, inlet pipe and pilot pipe from the valve.
- 4.6.3 Remove the valve retaining screws and remove. Re-assemble in reverse order and carry out a gas tightness test. Re-fit coals as shown in section 3. The fender and ash pan cover can now be re-positioned.

### **4.7 Removing the pilot assembly.**

**Note : Because this appliance is fitted with an atmosphere sensing ‘Oxy-Pilot’ it is not possible to replace the thermocouple separately, because the thermocouple position is factory set to a tight tolerance. Any replacement of parts on the pilot requires a complete new pilot assembly.**

- 4.7.1 Remove the burner assembly as in section 4.5.
- 4.7.2 Unscrew the thermocouple retaining nut from the solenoid.
- 4.7.3 Loosen the pilot nut and remove two screw retaining the pilot assembly.
- 4.7.4 Re-assemble in reverse order and carry out a gas tightness test. Re-fit coals as shown in section 3. The fender and ash pan cover can now be re-positioned.

#### **4.8 Replacing the batteries (within the firebox)**

- 4.8.1 Remove the fender and ashpan assembly The battery holder is located on the right hand side of the appliance .
  - 4.8.2 Remove the battery pack with care and then disconnect the battery lead at the white rectangular plug and socket.
  - 4.8.3 Replace in reverse order and check correct operation of the appliance.
- NB The handset uses one LR61 (9v) and should be replaced by removing the cover on the rear of the handset.

#### **ENSURE THE BATTERIES ARE CONNECTED TO THE CORRECT POLARITY POSITIVE (+), NEGATIVE (-)**

#### **4.9 Removing the trim switch (electronic fire control models only)**

- 4.9.1 Remove the burner assembly as in section 4.5 and disconnect the trim switch cable from the control board.
- 4.9.2 Remove the 4 off trim switch mounting screws from the front flange of the firebox.
- 4.9.3 Remove the 3 off trim switch retaining screws from the mounting plate, take care to retain the insulating washers with the screws for re-use.
- 4.9.4 Lift the trim switch clear, replace in reverse order and carry out a gas tightness test.

**NOTE :** WHEN RE-FITTING THE BURNER PLEASE ENSURE THAT THE TRIM SWITCH CABLE IS COILED UP AND CORRECTLY REPLACED BELOW THE HEAT SHIELD. DO NOT LEAVE THE WIRING LOOSE AS ANY CONTACT WITH THE BURNER WILL CAUSE DAMAGE TO THE WIRING.



## FRET INFORMATION

To enable Customers to choose their own style of fret these fires are now available without frets. In order to maintain the efficient and safe operation of the fire it is important that any fret which is used must comply with the following dimensions. (figure 26). It is important to clean a fret in accordance with the instructions provided by your retailer as these vary depending on the surface finish of the fret.

**Fig. 26**

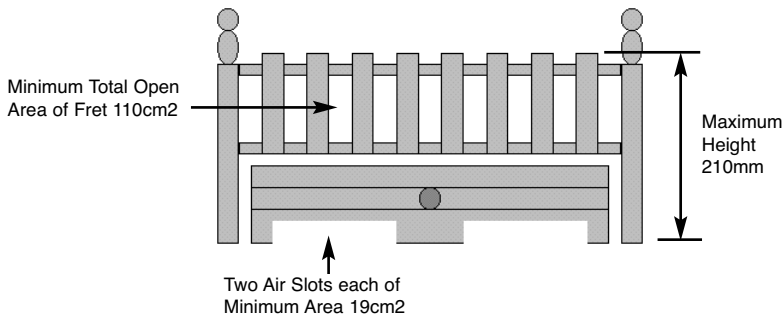

## PARTS SHORTLIST

Replacement of parts must be carried out by a competent person such as a GAS SAFE registered gas installer. The part numbers of the replaceable parts are as follows, these are available from BFM Europe who may be contacted at the address shown on the rear cover.

Complete coal / ceramic pack	B-148190
Coal fuel-bed matrix	B-147750
Replacement coal set	B-151930
Complete pebble / ceramic set	B-68220
Pebble fuelbed base	B-68230
Replacement pebble set	B-68240
RC gas control valve	B-106790
RC control board	B-129140
RC battery cable	B-106810
RC battery holder	B-106820
Piezo igniter	B-1320
Ignition wire manual control models	B-67910
Ignition wire remote / EFC models	B-63650
Manual gas valve	B-67090
Remote valve	B-106790

## SECTION FIVE - USER INSTRUCTIONS

### 5.1 INSTALLATION INFORMATION

#### CONDITIONS OF INSTALLATION

It is the law that all gas appliances are installed only by a competent (e.g. GAS SAFE registered) Installer, in accordance with the installation instructions and the Gas Safety (Installation and Use) Regulations 1998. Failure to install appliances correctly could lead to prosecution. It is in your own interest and that of safety to comply with the law.

The fire may be fitted below a combustible shelf provided that the shelf is at least 200mm above the top of the appliance and the depth of the shelf does not exceed 150mm.

The fire may be installed below combustible shelves which exceed 150mm deep providing that the clearance above the fire is increased by 15mm for each 25mm of additional overhang in excess of 150mm.

**No purpose made additional ventilation is normally required for this appliance when installed in G.B. When installed I.E. please consult document I.S. 813 : 1996 Domestic Gas Installation which is issued by the National Standards Authority of Ireland. Any purpose made ventilation should be checked periodically to ensure that it is free from obstruction.**

If the chimney or flue has been previously used by appliances burning fuels other than gas they must be swept prior to the installation of this fire.

If this appliance is fitted directly on to a wall without the use of a fireplace or surround, soft wall coverings such as wallpaper, blown vinyl etc. could be affected by the heat and hot convection air and may discolour or scorch. This should be considered when installing or decorating.

The Model number of this appliance is as stated on the rating plate affixed to the control panel of the fire and the appliance is manufactured by:-

BFM Europe Ltd  
Trentham Lakes  
Stoke on Trent  
ST4 4TJ

## **ABOUT YOUR NEW VERINE MIDAS PLUS GAS FIRE**

The Verine Midas Plus coal effect gas fire incorporates a unique and highly developed fuel bed which gives the realism of a loose coal layout combined with realistic flames and glow. The use of durable ceramic material in the construction of the fuelbed components ensures long and trouble free operation.

When first using the new fire a slight smell may be noticed. This is due to starch used in the manufacture of the soft ceramic coals / pebbles, it is non-toxic and will soon disappear.

Please take the time to fully read these instructions as you will then be able to obtain the most effective and safe operation of your fire.

## **IMPORTANT SAFETY INFORMATION**

### **WARNING**

**This appliance has a naked flame and as with all heating appliances a fireguard should be used for the protection of children, the elderly and infirm. Fireguards should conform to B.S. 8423 : 2002 (Fireguards for use with gas heating appliances).**

It is important that this appliance is serviced at least once a year by a GAS SAFE registered installer and that during the service the fire is removed from the fire opening and the chimney or flue visually checked for fallen debris or blockages which must be removed. The chimney should also be checked to ensure clearance of flue products.

**After installation or during servicing a spillage test must always be carried out.**

Rubbish of any type must NEVER be thrown onto the fuel bed, this could affect safe operation and damage the fire.

Any debris or deposits should be removed from the fuel bed from time to time. This may be carried out by referring to the cleaning section as described later in this book.

Only the correct number and type of coals / pebbles must be used and only complete and genuine replacement sets must be used.

Always keep furniture and combustible materials well clear of the fire and never dry clothing or items either on or near to the fire. Never use aerosols or flammable cleaning products near to the fire when it is in use.

**The ceramic fuel bed remains hot for a considerable period after use and sufficient time should be allowed for the fire to cool before cleaning etc.**

## 5.2 OPERATING THE FIRE - MANUAL CONTROL MODELS

- a) The controls are located behind the ashpan cover which is situated below the fret or contemporary ashpan cover. The controls, comprise a control valve to adjust the gas flow and a push button piezo igniter. To light the fire proceed as follows:-
- b) Depress the control knob and turn anti-clockwise to the position marked ignition rate. Hold in the control knob for a few seconds to allow the gas to reach the burner.
- c) Continue to hold-in the control knob and press the igniter button. If the burner does not light, continue to press the igniter button until ignition occurs. When the pilot has lit, continue to hold the control knob in for a minimum of 20 seconds to allow the thermocouple to heat up, if the burner goes out when the control knob is released, repeat the lighting sequence.
- d) In the unlikely event of a failure of the igniter, the fire can be lit as follows :- Depress the control knob and turn anti-clockwise to the position marked ignition rate. Hold in the control knob for a few seconds to allow the gas to reach the burner. Insert the tip of a lit taper in below the fuelbed ceramic matrix above the thermocouple tip. This will light the main burner at low rate (2.2kW)
- e) After lighting, turn the control knob in the anti-clockwise direction to the high position (6.5kW). It is recommended that for most efficient performance the fire is allowed to warm up for a few minutes with the gas control on maximum.
- f) The gas control can be turned clockwise from the maximum position to give the desired heat output.

**WARNING :** If the fire goes out for any reason or is turned off and it is necessary to re-light the fire it is important to allow the fire to cool for 3 minutes before attempting to re-light it.

**Please Note :** The life span of the batteries in the burner unit is dependent upon use and therefore the battery life will vary accordingly. If the burner unit fails to operate on slide, remote or electronic fire control models, please check the 1 off AA battery in slide control models or 6 off AA batteries in remote and electronic fire control model before calling the service centre for engineer assistance. Service calls as a result of flat batteries are chargeable.

### 5.3 LIGHTING THE FIRE - ELECTRONIC FIRE CONTROL MODELS

- a) The control comprises an electronic fire control (EFC) trim switch to ignite the fire and adjust the gas flow. The electronic fire control trim switch is located at the top right hand side of the fire. To light the fire proceed as follows:-  
To light the fire using the electronic fire control (trim switch), press the ignition button as indicated below in figure 2. The fire will emit a “beep” sound, the button can now be released. After a few seconds an audible clicking can be heard and then the fire will light the pilot and then light the main burner. The ignition cycle will take approximately 20 seconds. It is recommended that for the most efficient performance the fire is allowed to warm up for a few minutes with the input set to high.
- b) To reduce the level of heat input on the fire, press the small flame button on the trim switch. (An audible beep will be heard)
- c) To increase the level of heat input on the fire, press the large flame button on the trim switch. (An audible beep will be heard)
- d) To leave the fire in the standby mode (pilot only running) press the small round button on the trim switch. (An audible beep will be heard). **The fire should not be left in the standby mode when unattended.**
- e) To switch the appliance off completely, press the Ignition / Off button on the trim switch, the fire will then switch off. (An audible beep will be heard)

Fig. 2

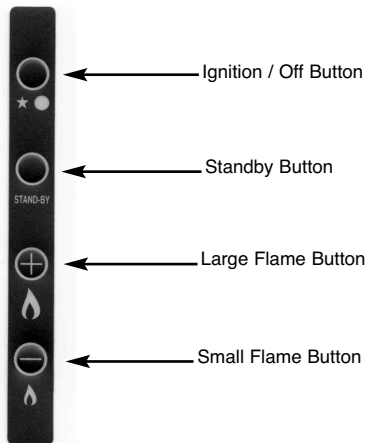

**WARNING :** If the fire goes out for any reason or is turned off and it is necessary to re-light the fire it is important to allow the fire to cool for 3 minutes before attempting to re-light it.

**Please Note :** The life span of the batteries in the burner unit is dependent upon use and therefore the battery life will vary accordingly. If the burner unit fails to operate on slide, remote or electronic fire control models, please check the 1 off AA battery in slide control models or 6 off AA batteries in remote and electronic fire control model before calling the service centre for engineer assistance. Service calls as a result of flat batteries are chargeable.

#### **5.4 OPERATING THE FIRE - REMOTE CONTROL CONTROLS**

The controls comprise a remote control handset to ignite the fire and adjust the gas flow. The Remote control handset generates an infrared signal, which will be received by the sensor situated at the front of your fire, below the ashpan cover. This infrared signal requires direct line of sight from the handset to the sensor on the fire to ensure good operation. To light the fire proceed as follows:-

- a) To light the appliance using the handset, point the handset at the fire and press the 2 left hand buttons together. The fire will emit a “beep” sound, the buttons can now be released. After a few seconds an audible clicking can be heard and then the fire will light the pilot and then light the main burner. The ignition cycle will take approximately 20 seconds. It is recommended that for the most efficient performance the fire is allowed to warm up for a few minutes with the input set to high.
- b) To reduce the level of heat input on the fire, point the handset at the fire and press the small flame button once. (An audible beep will be heard) and the heat input level will reduce to the low setting (2.2kW). Press and continually hold the small flame button and the fire will reduce incrementally to the low setting (2.2kW)
- c) To increase the level of heat input on the fire, point the handset at the fire and press the large flame button. (An audible beep will be heard) and the heat input level will increase to the high setting (6.2kW) Press and continually hold the small flame button and the fire will reduce incrementally to the high setting (6.2kW)
- d) To leave the fire in the standby mode (pilot only running) press the small round button on the handset. **The fire should not be left in the standby mode when unattended.**
- e) To switch the appliance off completely, press the large round button on the handset, the fire will then switch off. See figure 2 overpage for image of the handset.

**Fig. 2**

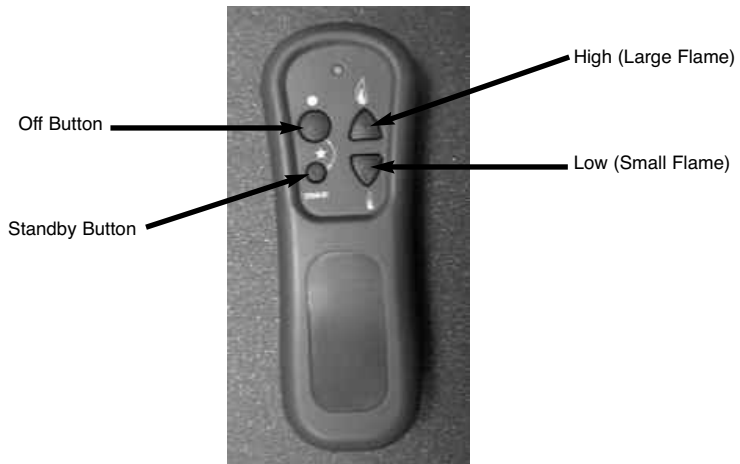

**WARNING :** If the fire goes out for any reason or is turned off and it is necessary to re-light the fire it is important to allow the fire to cool for 3 minutes before attempting to re-light it.

## 5.5 TURNING THE PRODUCT OFF IN THE UNLIKELY EVENT OF A REMOTE HANDSET OR EFC TRIM SWITCH MALFUNCTION.

- a) In the unlikely event of the remote control handset or EFC trim switch malfunctioning (or if lost or broken) after the appliance has been turned on, the fire can be turned off via the emergency shut off switch on the control panel.
- b) To turn the product off, firstly remove the ashpan from the fire.
- c) Press and hold the emergency shut off switch until the fire shuts down. The process may take up to sixty seconds to complete. (see figure 3 below).
- d) When the fire has shut down, release the emergency shut off switch.
- e) The appliance will now remain in the “off” position until activated by the remote handset / EFC trim switch (whichever is applicable).

Fig. 3

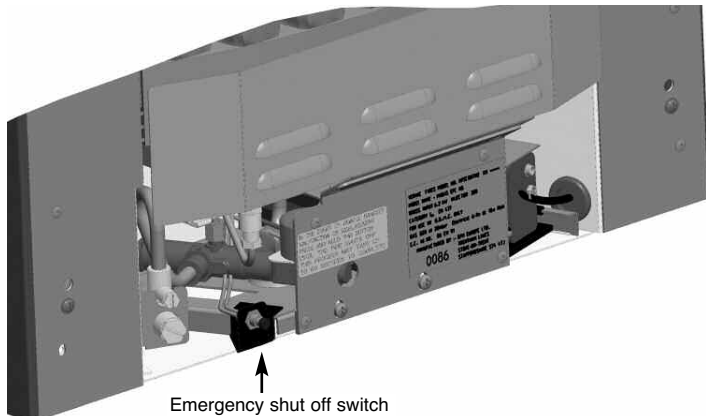

## 5.6 REPLACING THE BATTERIES - REMOTE CONTROL / ELECTRONIC FIRE CONTROL MODELS

- a) Remove the ashpan cover
- b) The battery pack is located on the right hand side side of the burner unit at the bottom.
- c) Carefully remove the pack and remove the batteries.
- d) Replace in the reverse order using 6 off 1.5V AA Alkaline Battery. **It is important that only an alkaline battery is used, otherwise premature battery failure and leakage may result.**



## 5.7 SPILLAGE MONITORING SYSTEM

All models regardless of control type are fitted with a spillage monitoring system which shuts down the fire if the evacuation of combustion products from the fire is affected by a partially or fully blocked flue. If this system operates the fire will go out. If this occurs, leave the fire for at least three minutes then follow the lighting procedure as described in the previous section. **In the event of repeated operation a GAS SAFE registered gas engineer must be called to investigate and rectify the cause.**

## 5.8 CLEANING - WARNING

Before attempting any cleaning operation ensure that the fire has been allowed to fully cool.

### CLEANING THE TRIMS AND PAINTED METAL PARTS

Dependent upon the trim option chosen for use with this fire, there is a variety of methods that can be chosen to clean the trim. If a Brass trim was supplied with this fire this is plated brass and this trim must only be cleaned using a clean damp cloth. Metal polishes must not be used on these trims. If a black trim was chosen, then these should only be cleaned using a clean, damp cloth also. The trim is best cleaned by removing it from the fire and placing it face up on a flat surface. The fender that was supplied with the fire is laquered to protect the finish and therefore must only be cleaned using a clean damp cloth.

**Abrasive cleaners, chemical cleaning agents or any type of polish must never be used as damage to the finish may result.**

### CLEANING THE FUEL BED

We do not recommend cleaning of coals / pebbles or fuelbed components as these are fragile and damage may result. **None of these parts must be washed or exposed to any cleaning agents or water.** Any damaged parts must be replaced by contacting your dealer or telephoning BFM Europe Ltd on the number stated on the rear cover of this book. Coals / pebbles must only be replaced with a complete and genuine replacement set and the fire must never be run with the wrong number or damaged coals. The fuelbed must be carefully re-assembled as stated in the following section.

## 5.9 RE-ASSEMBLING THE FUEL-BED - COAL MODELS

- a) Place the fuelbed base centrally on to the fuelbed support and push fully backwards to the rear face of the fibre boards **Make sure that the fuelbed base is located centrally in the fire box, behind the retaining tabs as shown below.** Fit 7 off small coals along the front edge of the fuelbed base as shown below in figure 4.

Fig. 4

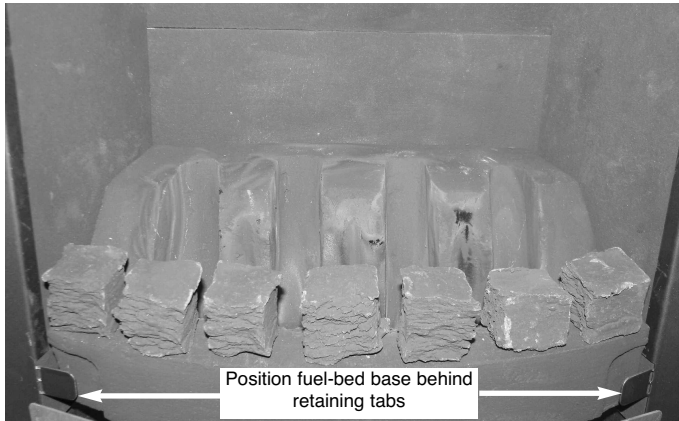

- b) Select 4 off large coals and arrange behind the front row of coals, ensuring that flame paths as indicated below are not interrupted, see figure 5 below.

Fig. 5

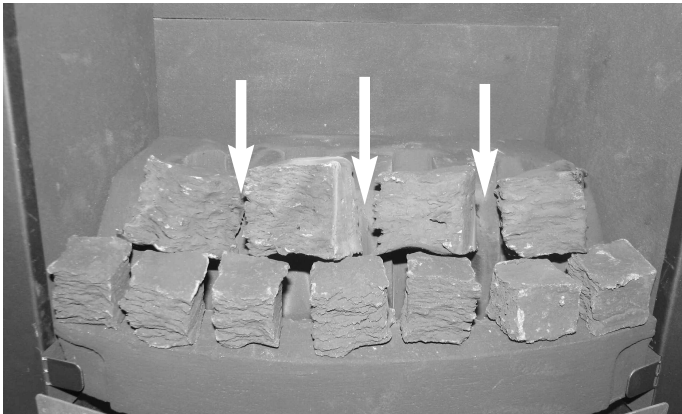

- c) Select 3 off large coals and arrange along the rear of the fuelbed, using the ribs in the rear of the fuelbed as a guide for placement, see figure 6 below.

**Fig. 6**



- d) Select 2 off small coals and arrange at the left hand and right hand end of the third row of coals, see figure 7 below.

**Fig. 7**



- d) Select 6 off small coals and arrange along the rear of the fuel-bed as shown below in figure 8.

**Fig. 8**



**The exact position and fit of the coals may be finely adjusted to give the best appearance.**

**Warning : Use only the coal set supplied with the fire. When replacing the coals remove the old coals and discard them. Fit a complete set of coals of the correct type. Do not fit additional coals or any coals other than a genuine replacement set.**

This appliance uses fuel effect pieces containing Refractory Ceramic Fibres (R.C.F.), which are man-made vitreous silicate fibres. Excessive exposure to these materials may cause temporary irritation to eyes, skin and respiratory tract. Consequently, it makes sense to take care when handling these articles to ensure that the release of dust is kept to a minimum. To ensure that the release of fibres from these R.C.F. articles is kept to a minimum, during installation & servicing we recommend that you use a HEPA filtered vacuum to remove any dust and soot accumulated in and around the fire, before and after working on the fire. When replacing these articles we recommend that the replaced items are not broken up, but are sealed within a heavy duty polythene bag, clearly labelled as "RCF waste". This is not classified as "hazardous waste" and may be disposed of at a tipping site licensed for the disposal of industrial waste. Protective clothing is not required when handling these articles, but we do recommend you follow the normal hygiene rules of not smoking, eating or drinking in the work area, and always wash your hands before eating or drinking. This appliance does not contain any component manufactured from asbestos or asbestos related products.

## 5.9 RE-ASSEMBLING THE FUEL-BED - PEBBLE MODELS

- a) Place the fuelbed base centrally on to the fuelbed support and push fully backwards to the rear face of the fibre boards **Make sure that the fuelbed base is located centrally in the fire box, behind the retaining tabs** as shown below in figure 9.

Fig. 9

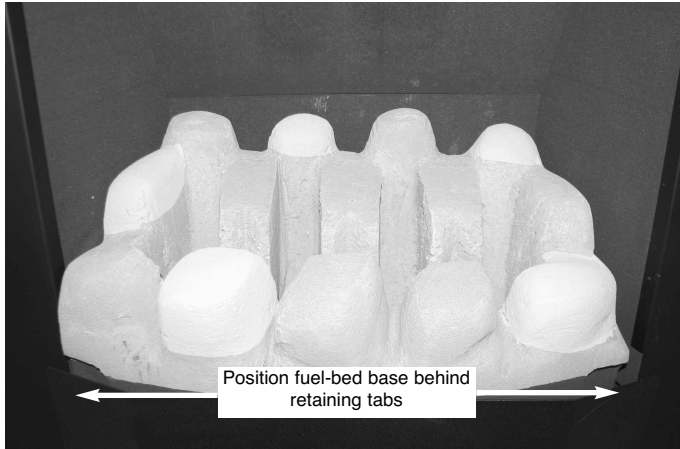

- b) Position the front row of four large loose pebbles along behind the first row of pebbles, ensuring that the flame paths as indicated are not interrupted. See figure 10 below.

Fig. 10

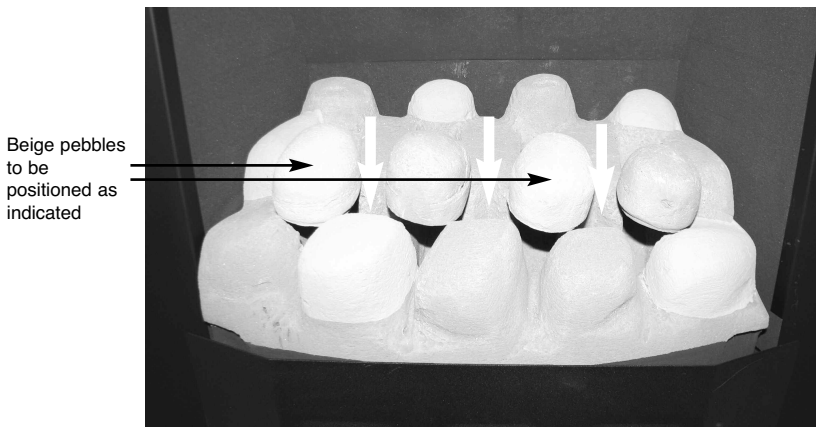

- c) Fit the three small pebbles onto the ribs in the fuelbed as shown below, ensuring that the rear flame paths as indicated are not interrupted. See figure 11 below.

**Fig. 11**

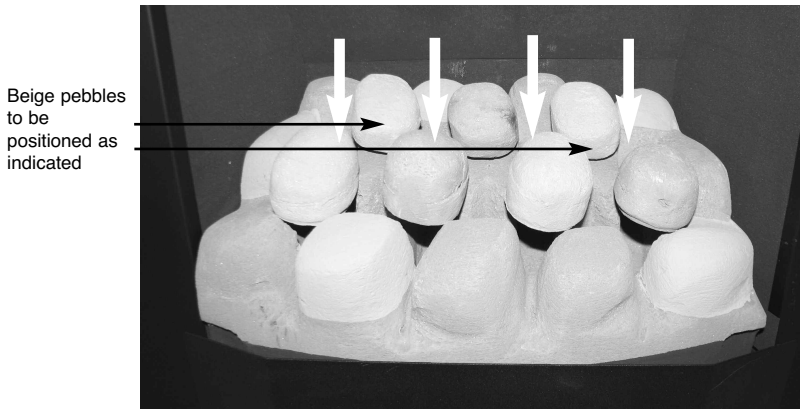

The exact position and fit of the pebbles may be finely adjusted to give the best appearance.

**Warning :** Use only the pebble set supplied with the fire. When replacing the pebbles remove the old pebbles and discard them. Fit a complete set of pebbles of the correct type. Do not fit additional pebbles or any pebbles other than a genuine replacement set.

This appliance uses fuel effect pieces containing Refractory Ceramic Fibres (R.C.F.), which are man-made vitreous silicate fibres. Excessive exposure to these materials may cause temporary irritation to eyes, skin and respiratory tract. Consequently, it makes sense to take care when handling these articles to ensure that the release of dust is kept to a minimum. To ensure that the release of fibres from these R.C.F. articles is kept to a minimum, during installation & servicing we recommend that you use a HEPA filtered vacuum to remove any dust and soot accumulated in and around the fire, before and after working on the fire. When replacing these articles we recommend that the replaced items are not broken up, but are sealed within a heavy duty polythene bag, clearly labelled as "RCF waste". This is not classified as "hazardous waste" and may be disposed of at a tipping site licensed for the disposal of industrial waste. Protective clothing is not required when handling these articles, but we do recommend you follow the normal hygiene rules of not smoking, eating or drinking in the work area, and always wash your hands before eating or drinking. This appliance does not contain any component manufactured from asbestos or asbestos related products.

## **USER REPLACEABLE PARTS**

The only user replaceable parts on this fire are the fuelbed components and coals / pebbles which may be replaced as described in the above section. Replacement of any other parts must be carried out by a competent person such as a GAS SAFE registered gas installer.

The part numbers of the user replaceable parts are as follows, these are available from BFM Europe Ltd whose contact details may be found overpage.

Complete coal / ceramic pack	B-148190
Coal fuel-bed matrix	B-147750
Replacement coal set	B-151930
Complete pebble / ceramic set	B-68220
Pebble fuelbed base	B-68230
Replacement pebble set	B-68240

Due to our policy of continual improvement and development the exact accuracy of illustrations and descriptions contained in this book cannot be guaranteed

**Part No. B-153680**

**Issue 3**

**VERINE**  
FIRES TO INSPIRE

BFM Europe Ltd.  
Trentham Lakes  
Stoke-on-Trent  
Staffordshire  
ST4 4TJ

[www.bfm-europe.com](http://www.bfm-europe.com)

**Telephone - General Enquiries :**

**(01782) 339000**

**Telephone - Service :**

**(0844) 7700169**