



*Fire Your Imagination*

# Riva Vision Range

## Conventional Flue Log Effect Stove



**IMPORTANT:**  
FOR EASY TO FOLLOW,  
STEP BY STEP VIDEO  
INSTRUCTIONS ON HOW TO  
OPERATE AND MAINTAIN YOUR  
GAZCO REMOTE SYSTEM GO TO  
[WWW.GAZCO.TV](http://WWW.GAZCO.TV)

# Instructions for Use, Installation and Servicing

For use in GB, IE (Great Britain and Republic of Ireland)

## **IMPORTANT**

**THE OUTER CASING, FRONT AND GLASS PANEL BECOME EXTREMELY HOT DURING OPERATION AND WILL RESULT IN SERIOUS INJURY AND BURNS IF TOUCHED. IT IS THEREFORE RECOMMENDED THAT A FIREGUARD COMPLYING WITH BS 8423:2002 IS USED IN THE PRESENCE OF YOUNG CHILDREN, THE ELDERLY OR INFIRM.**

This product contains a Heat resistant glass panel. This panel should be checked during Installation and at each servicing interval. If any damage is observed on the front face of the glass panel (scratches, scores, cracks or other surface defects), the glass panel must be replaced and the appliance must not be used until a replacement is installed. Under no circumstances should the appliance be used if any damage is observed, the glass panel is removed or broken.

It is essential that ALL of the screws that retain the glass frame are replaced and tightened correctly. Under no circumstances should the appliance be operated if any of these screws are loose or missing.

These Instructions must be left with the appliance for future reference and for consultation when servicing the appliance. Please make the customer aware of the correct operation of the appliance before leaving these instructions with them.

The commissioning sheet found on Page 3 of this Instruction manual must be completed by the Installer prior to leaving the premises.

# Contents

Covering the following models:

Model	NATURAL GAS		LPG	
	Top Exit	Rear Exit	Top Exit	Rear Exit
Riva Vision Small	526-166	526-192	526-548	526-710
Riva Vision Midi	526-393	526-313	526-570	526-746
Riva Vision Medium	526-198	526-243	526-469	526-402

**Appliance Commissioning Checklist .....3**

**User Instructions .....4**

**Installation Instructions .....15**

Technical Specifications ..... 15

Site Requirements ..... 17

Installation ..... 19

Commissioning .....27

**Servicing Instructions.....29**

Fault Finding..... 29

How to replace parts ..... 32

Basic spare parts list ..... 41

Service Records .....42



To receive your Extended Warranty your Gazco appliance must have been purchased from our Expert Retailer Network and registered within one month of purchase or installation. Please note that all warranties are effective from the date of purchase. Any Gazco product purchased outside of our Extended Retailer Network, or not registered within the stated time will carry a standard 12 month warranty.

It is a condition of the Extended Warranty that the installation complies with the relevant Building Regulations and is carried out by a suitably trained and qualified individual (GasSafe in the UK or equivalent in other countries) with the certificate of installation and the Commissioning Report on Page 3 completed and retained by the end user.

Full terms and conditions are detailed in the Warranty Statement on the Gazco website [www.gazco.com](http://www.gazco.com). In the event of any conflict of information the wording on the website shall prevail.

**Important Note:** Should any problems be experienced with your product, claims must first be submitted to the Expert Retailer where the appliance was purchased from who will offer immediate assistance or contact Gazco on your behalf.

# Appliance Commissioning Checklist

To assist us in any guarantee claim please complete the following information:-

## IMPORTANT NOTICE

Explain the operation of the appliance to the end user, hand the completed instructions to them for safe keeping, as the information will be required when making any guaranteed claims.

FLUE CHECK	PASS	FAIL
1. Flue Is correct for appliance		
2. Flue flow Test		
3. Spillage Test		
GAS CHECK		
1. Gas soundness & let by test		
2. Standing gas pressure	mb	
3. Appliance working pressure (on High Setting NB All other gas appliances must be operating on full	mb	
4. Gas rate	m <sup>3</sup> /h	
5. Does Ventilation meet appliance requirements N/A		
SAFETY CHECK		
1. Glass checked to ensure no damage, scratches, scores or cracks.		
2. Glass frame secured correctly and all screws replaced		

## RETAILER AND INSTALLER INFORMATION

**Retailer**.....  
 .....  
 .....  
**Contact No.**.....  
**Date of Purchase**.....  
**Model No.**.....  
**Serial No.**.....  
**Gas Type**.....

**Installation Company**.....  
 .....  
 .....  
**Engineer**.....  
**Contact No.**.....  
**Gas Safe Reg No.**.....  
**Date of Installation**.....

# User Instructions

## Welcome

*Congratulations on purchasing your Vision stove, if installed correctly Gazco hope it will give you many years of warmth and pleasure for which it was designed.*

*The purpose of this manual is to familiarise you with your appliance, and give guidelines for its installation, operation and maintenance. If, after reading, you need further information, please do not hesitate to contact your Gazco retailer.*

## WARNING



**In the event of a gas escape or if you can smell gas, please take the following steps:**

- **Immediately turn off the gas supply at the meter/emergency control valve**
- **Extinguish all sources of ignition**
- **Do not smoke**
- **Do not operate any electrical light or power switches (On or Off)**
- **Ventilate the building(s) by opening doors and windows**
- **Ensure access to the premises can be made**

**Please report the incident immediately to the National Gas Emergency Service Call Centre on 0800 111 999 (England, Scotland and Wales) , 0800 002 001 (N. Ireland) or in the case of LPG, the gas supplier whose details can be found on the bulk storage vessel or cylinder.**

**The gas supply must not be used until remedial action has been taken to correct the defect and the installation has been recommissioned by a competent person.**

## 1. General

- 1.1 Installation and servicing must only be carried out by a competent person whose name appears on the Gas Safe register. To ensure the engineer is registered with Gas Safe they should possess an ID Card carrying the following logo:



- 1.2 In all correspondence, please quote the appliance type and serial number, which can be found on the data badge located on a plate attached to the lower slotted trim.

- 1.3 **Do not** place curtains above the appliance: You must have 300mm (1') clearance between the appliance and any curtains at either side.
- 1.4 No furnishings or other objects should be placed within 1 metre of the front of the appliance.
- 1.5 If a shelf is fitted, a distance of 225mm above the appliance is required.
- 1.6 If any cracks appear in the glass panel do not use the appliance until the panel has been replaced.
- 1.7 In the unlikely event the appliance is receiving interference from other electronic devices, the handset/Control box can be reprogrammed. Please refer to the commissioning section in order to change the communication channel.
- 1.8 If, for any reason, the flue has to be removed from the appliance, the seals must be replaced in the inner spigot.
- 1.9 This product is guaranteed for 5 years from the date of installation, as set out in the terms and conditions of sale between Gazco and your local Gazco retailer. Please consult with your local Gazco retailer if you have any questions. In all correspondence always quote the Model Number and Serial Number.

## 2. Control Options

- 2.1 The appliance has 4 flame settings:
1. High.
  2. Medium.
  3. Low.
  4. Standby (Pilot only).
- 2.2 Both touch pad and handset allow you to manually switch between flame settings.
- 2.3 The Thermostatic handset also allows to set the appliance to automatically regulate the room temperature.

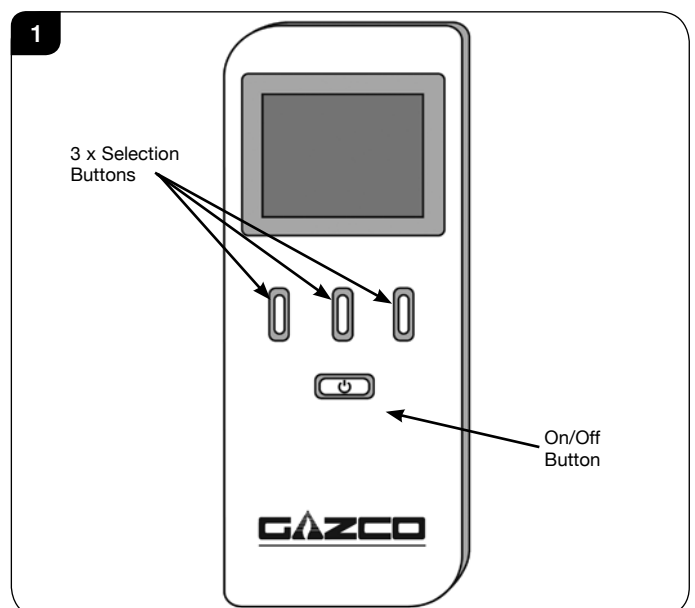

# User Instructions

## Before using the remote control:

- 2.4 If there is no display on the LCD screen press any key.
- 2.5 When first powered, the handset displays the OFF screen. The handset may be locked as indicated by the padlock symbol (🔒), see Diagram 2.

**NOTE: To select a function from the options displayed at the bottom of the screen press the button directly below the desired function.**

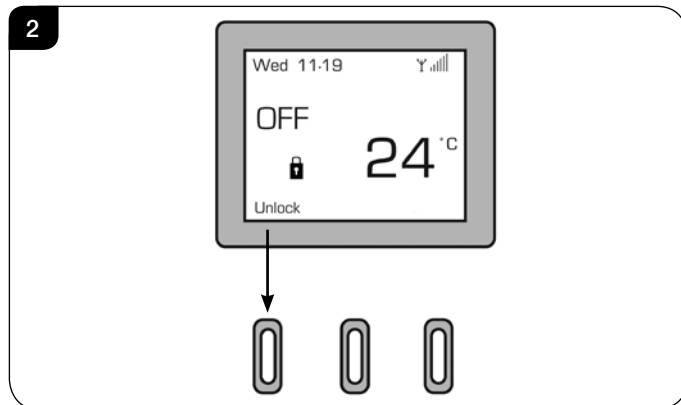

- 2.6 To unlock the handset select Unlock followed by OK - the symbol will change to an open padlock (🔓).
- 2.7 There are 3 different modes available for controlling and operating the appliance:
1. Manual Mode - See Page 6.
  2. Automatic Mode - See Page 6.
  3. Program Mode - See Page 7.

When a command from the handset is received a beep will sound and the LED on the handset will briefly illuminate.

**NOTE:** The LED flashes every 4 seconds to show that it is communicating with the appliance. After each command has been accepted the LED will cease flashing until the command has been carried out. Wait until the LED resumes flashing before giving another command.

## Advanced Controls

- 2.8 The thermostatic remote control handset has been pre-set as follows:
- Thermostat mode - the appliance will alter automatically to achieve and maintain a desired room temperature in Auto (Fixed Temp) or Program mode.
  - Gap temperature set at 2°C - in Auto or Program mode the appliance will automatically ignite if the room temperature falls 2°C below the fixed temperature.
  - Program mode enabled - this allows one of three temperatures (Night temperature, Comfort temperature or Off) to be set for each hour of the day on a daily or weekly cycle.

d) Soft start enabled - in Auto or Program mode there is a 10 second delay between flame settings when more than one change of setting is required (i.e. from High to Low).

e) Sounder ON - the appliance will beep to confirm that it has received a command from the handset or touch pad.

f) Safety Temperature pre-set at 40°C - the appliance will automatically switch off if the room temperature (as displayed on the handset) exceeds 40°C.

**NOTE: If the Safety Temperature is exceeded the appliance can not be turned on again until the room temperature has dropped below the safety temperature.**

2.9 The LCD screen displays the following information, see Diagram 3.

- 1) Time (24 hr clock)
- 2) Signal strength (between handset and appliance)
- 3) Selected Setting - set fixed temperature (in degrees) when in Auto mode (small number)
- 4) Current room temperature (large number)
- 5) Button function
- 6) Child lock status (shown by open or closed padlock)
- 7) Current flame status (Low, Med, High)
- 8) Selected Mode - Manual Flame / Fixed Temp (Auto) / Program - when appliance is switched on
- 9) Day of the week (Mon - Sun)

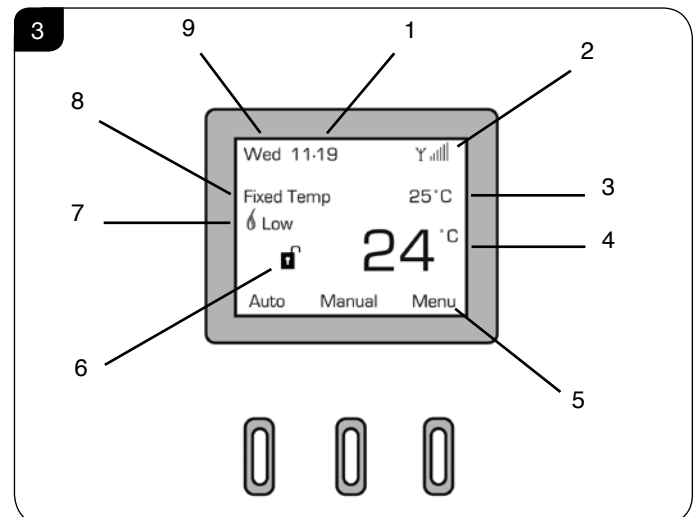

# User Instructions

## 1. Manual Mode

### Switching the Appliance ON:

- 2.10 To light the appliance press the On/Off (⏻) button, this will bring up the LCD screen. Select the 'On' option on the left of the screen immediately followed directly by the OK button, a single beep will sound.

After the start up cycle has completed the appliance will light on the high flame setting (this can take up to 20 seconds).

Select the 'Manual' option on the screen to control the appliance.

### Decreasing the Flame Height:

- 2.11 From the high flame setting press DOWN (↓) once to lower the flame to the medium setting.
- 2.12 From the medium flame setting press DOWN (↓) once to lower the flame to the low setting.
- 2.13 From the low flame setting press DOWN (↓) once to put the appliance in Standby mode (Pilot only).

### Increasing the Flame Height:

- 2.14 To light the appliance when it is in Standby mode press UP (↑) once. The appliance will light on the **Low** flame setting.
- 2.15 From the low setting press UP (↑) once to increase the flame setting to medium.
- 2.16 From the medium setting press UP (↑) once to increase the flame setting to high.



**WARNING: IF THE APPLIANCE FAILS TO LIGHT OR BECOMES EXTINGUISHED IN USE, WAIT 3 MINUTES BEFORE ATTEMPTING TO RELIGHT.**



**IMPORTANT: YELLOW FLAMES TYPICALLY APPEAR WHEN THE APPLIANCE HAS REACHED NORMAL OPERATING TEMPERATURE. THIS CAN TAKE UP TO 30 MINUTES.**

### Switching the Appliance OFF:

- 2.17 To switch the appliance OFF press the On/Off (⏻) button once, see Diagram 1.

## 2. Automatic Mode

Auto mode allows you to pre-set a room temperature. The appliance controls the flame setting automatically to achieve and maintain this temperature.

**NOTE: WHEN IN AUTOMATIC MODE, THE PILOT REMAINS LIT AND THE MAIN BURNER AUTOMATICALLY ADJUSTS TO MAINTAIN THE FIXED TEMPERATURE WHETHER OR NOT ANYONE IS IN THE ROOM.**

- 2.18 If the appliance is switched off, select On followed by OK. The appliance will emit a single beep and the pilot will light.

- 2.19 Select Auto. The screen will display the word 'Thermo' and the current fixed room temperature will be highlighted.

- 2.20 Use the buttons directly below the up (↑) or down (↓) symbols to select a temperature between 0°C and 37°C.

The flame setting required to achieve the desired room temperature will now be displayed below the word 'Thermo'.

- 2.21 The appliance will maintain the fixed temperature by automatically adjusting the flame height as follows:

a) If the room temperature falls 1°C below the fixed temperature the flame height will increase.

b) If the room temperature rises 1°C above the fixed temperature the flame height will decrease.

c) There will be a delay of 10 seconds between each flame setting adjustment.

- 2.22 Once the desired room temperature has been set, select Back to return to the main screen.

- 2.23 The screen will now display the words 'Fixed Temp', the chosen fixed temperature (e.g. 25°C) and the current room temperature (e.g. 24°C), see Diagram 4.

4

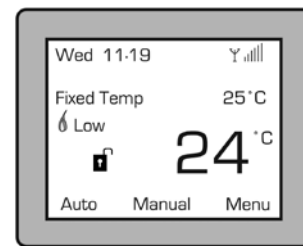

- 2.24 To change the fixed temperature at any time select Auto and follow 2.20.

- 2.25 To exit the Auto mode at any time select Manual and follow Section 2.22.

- 2.26 To turn off the appliance press the ON/OFF button once, see Diagram 2.

## Setting the Display

Items displayed on the main screen, such as day and time, can be set using the Adjust Menu function.

- 2.27 To access the Adjust Menu function select Menu from the main screen.

- 2.28 Select Adjust Menu. In this menu it is possible to set the:

Temperature Unit (°C/°F)

Language

Autolock (On/Off)

Day (Mon - Sun)

Hour (24hr clock)

Minute

Comfort temperature (for use when in Program mode)

Night temperature (for use when in Program mode)

# User Instructions

Access can be gained to the programmable functions via the Change Prog option (see Programming the Appliance).

## Setting the Day and Time:

- 2.29 Use (↓) to scroll down to Day and press Select. Use (↑) and (↓) to set the day of the week.
- 2.30 Press Back and scroll down to Hour and select it. Use (↑) and (↓) to set the hour.
- 2.31 Press Back and scroll down to Minute and press Select. Use (↑) and (↓) to set the minutes.
- 2.32 The same process can be used to set any of the functions within this menu.

## 3. Program Mode

Program mode allows the appliance to be pre-set to a choice of temperature options on a daily or weekly cycle. The appliance will automatically switch on and off and control the flame setting to maintain pre-set hourly temperatures during each 24hr period.

**NOTE: WHEN IN PROGRAM MODE, THE PILOT REMAINS LIT AND THE MAIN BURNER AUTOMATICALLY SWITCHES ON AT THE PROGRAMMED TIMES AND ADJUSTS THE FLAME HEIGHT TO BRING THE ROOM TO THE SET TEMPERATURE WHETHER OR NOT ANYONE IS IN THE ROOM.**

**Note: The current day and time must be set in order for the programmable functions to work. (See Section 2.28 for details).**

- 2.33 There are two types of program mode:
  1. Daily - the temperature can be set for each hour over a 24hr period - This pattern is then repeated every day.
  2. Weekly - the temperature can be set for each hour over a 24hr period for each individual day of the week (Mon - Sun). This pattern is then repeated every week.
- 2.34 One of 3 options can be chosen for each hour across a 24 hour period:
  - Off - the appliance will remain in Standby mode (pilot only). **The appliance will not switch off completely when in Program mode.**
  - Night Temp - the appliance will automatically maintain a pre-set night temperature.
  - Comfort Temp - the appliance will automatically maintain a pre-set comfort temperature.
- 2.35 To set the Comfort and Night temperature select Menu. In the next screen select Adjust Menu. Using (↓) scroll to Comfort Temperature and select. Use (↑) and (↓) to set a chosen temperature. Repeat for Night Temperature.
- 2.36 To access the programming screen select Menu. In the next screen select Adjust Menu. Using (↓) scroll to Change Prog and select. The programming screen will be displayed as shown in Diagram 5.

5

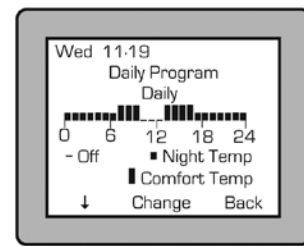

### Setting Daily Operating Times:

- 2.37 In the program menu highlight the word 'Daily'. Press (↓) to access the 24 hour timer below 'Daily'. The arrow should now point to the right (→).
- 2.38 The timer reads 0 - 24 with both 0 and 24 representing midnight. Press (→) to scroll through the 24 hour timer. With the cursor resting on the chosen hour, press Change until the desired setting for that hour (Comfort Temperature, Night Temperature or Off) is reached. Use (→) to scroll to the next hour and select the desired function for each hour until all 24 hours are set, see Diagram 6.

6

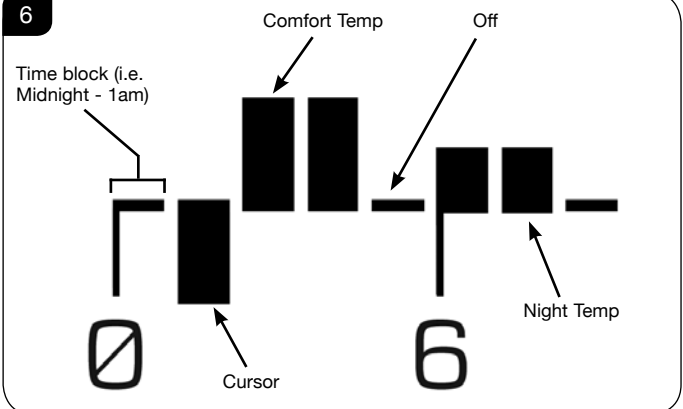

- 2.39 The program must now be launched. To do to this see Section 2.44.

### Setting Weekly Operating Times:

- 2.40 Access the programming screen as detailed in Section 2.36. The word 'Daily' will be highlighted. Select 'Change' to scroll from 'Daily' to the required day of the week (Monday - Sunday).
- 2.41 Press (↓) to access the timer. Select the function settings for each hour of the chosen day as detailed in 2.40. Repeat for the rest of the week.
- 2.42 Once the programming is completed select Back to return to the main screen.
- 2.43 The program must now be launched. To do to this see 2.44.

### Launching a Daily or Weekly Program:

- 2.44 Select Menu. In the next screen use (↓) to scroll to Program and confirm. Select Change until the highlighted text reads ON.

**Note: The appliance must be ON (pilot lit or any flame setting) in order to launch the program.**

# User Instructions

- 2.45 Select Back and use (↓) to select Prog Type. Select Change until the desired program (Daily or Weekly) is highlighted. Select Back twice to return to the main screen.

## To Switch Off Program Mode

- 2.46 To switch off the set program select Stop from the options on the main screen. The appliance will switch to Stand-by (pilot only). Alternatively select Auto; this will end the program cycle and return to the main screen. The appliance will automatically adjust the flame height to maintain any previously set Fixed Temperature.

## Locking the Handset

- 2.47 To lock the handset Select Lock. If the option is not visible on the screen (i.e. when the appliance is lit) select Menu and scroll down to Lock. Press Select and use the Change function to scroll to Yes. The handset is now locked.

## 3. Replacing the Handset Batteries

- 3.1 **BEFORE USE:**  
Ensure the remote handset contains 2 x AA 1.5v alkaline batteries (provided). Always replace the batteries with high quality batteries (Duracell or similar).  
**DO NOT USE RECHARGEABLE BATTERIES.**
- 3.2 Communication between the handset and the appliance may take up to 2 minutes after batteries have been replaced, check the strength of the signal in the top right hand corner of the LCD display (☺|||).
- 3.3 If communication is not regained after this time the control unit and the handset may need pairing. Please refer to Commissioning, Section 2, Pairing the Appliance.

## 4. Handset Troubleshooting



**IMPORTANT - THE CONTROL SYSTEM HAS BEEN PROGRAMMED TO CHANNEL 'C'. SOME HOUSEHOLD APPLIANCES MAY HAVE ALSO BEEN SET TO OPERATE ON THE SAME FREQUENCY. ALTHOUGH THIS HAS NO EFFECT ON THE SAFETY OF THE SYSTEM AN EXCESSIVE DELAY MAY BE ENCOUNTERED BETWEEN COMMANDS. IF THIS OCCURS FOLLOW THE INSTRUCTIONS IN COMMISSIONING SECTION 3 TO CHANGE THE CHANNEL.**

### CHANNEL SETTINGS

- 4.1 The appliance has been factory set to only communicate with the handset it is supplied with. It will not respond to any other remote control, even one from an identical appliance.

A replacement handset will need to be paired with the appliance before use. Please refer to Commissioning, Section 2, Pairing the Appliance.

### LOW BATTERY

- 4.2 If the batteries in the remote control handset become discharged the LCD display will show the message Low Battery.

Follow Section 3 - Replacing The Handset Batteries.

### REMOTE SIGNAL STRENGTH



**NOTE: If the handset is taken out of range the signal strength indicator will show 'Loss of Signal'. When the handset is returned to the appliance it will be necessary to press any button and wait for the signal indicator to recognise the handset. This can take up to 4 minutes**

- 4.3 If the appliance does not respond to the handset, check the strength of the signal in the top right hand corner of the LCD display (☺|||).

No vertical bars next to the signal symbol (☺) means communication between the appliance and the handset has been lost. If the communication loss exceeds 18 minutes the appliance will emit 20 beeps and switch OFF. Try the following:

- 4.4 Move the handset closer to the appliance.
- 4.5 Replace the batteries in the handset, see Section 3.
- 4.6 If there is still no signal, operate the appliance using the touch pad control, see Section 5 and consult your installer or Gazco retailer.

## 5. Touch Pad Control

The touch pad control is located adjacent to the battery holder behind the lower front cover or frame, see Diagram 8.

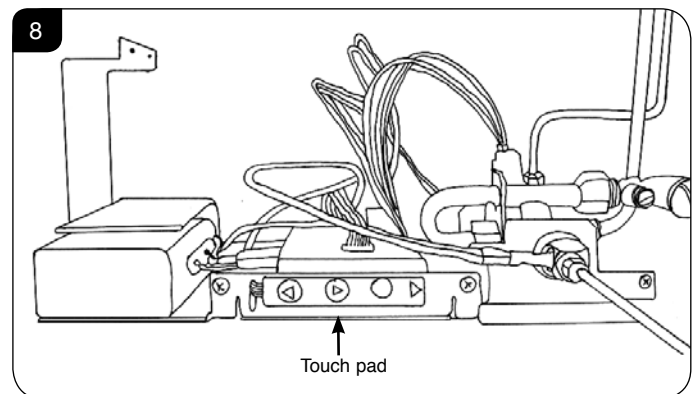

**When a command from the touch pad is received a beep will sound and the LED on the touch pad will briefly illuminate.**

**A second beep and flash of the LED will confirm the command has been carried out (this can take approximately 10 seconds). Wait for this confirmation before giving another command.**



# User Instructions

## Lighting the appliance

- 5.1 Press the On/Off button once.

If the pilot fails to light, press the ON/OFF button to switch OFF. Wait for at least 30 seconds before attempting to relight.

- 5.2 After the start up cycle has completed the appliance will light on the **high flame setting** (this can take up to 20 seconds).

If the appliance is in Standby mode, pressing the UP (▷) button will cause the main burner to ignite on the **Low** flame setting.

- 5.3 To increase the flame height press the UP (▷) button.

- 5.4 To decrease the flame height press the DOWN (◁) button.

- 5.5 When on the lowest flame setting pressing the Down (◁) button will switch the appliance to Standby mode (pilot only).

**WARNING: IF THE APPLIANCE FAILS TO LIGHT OR BECOMES EXTINGUISHED IN USE, WAIT 3 MINUTES BEFORE ATTEMPTING TO RELIGHT.**

**IMPORTANT: YELLOW FLAMES TYPICALLY APPEAR WHEN THE APPLIANCE HAS REACHED NORMAL OPERATING TEMPERATURE. THIS CAN TAKE UP TO 30 MINUTES.**

### To Switch the Appliance OFF:

- 5.6 To turn the appliance **OFF** press the On/Off button once.

## Touch Pad Control Not Working

### If the appliance is not operating with the touch pad control:

- 5.7 Replace the batteries in the battery pack, see Section 6.  
5.8 If the appliance still fails to operate consult your installer or Gazco retailer.

## 6. Changing the Appliance Batteries

- 6.1 The appliance batteries are located to the left hand side of the touch pad. This is behind the lower panel, see Diagram 9.  
To remove the panel lift slightly and pull forward.

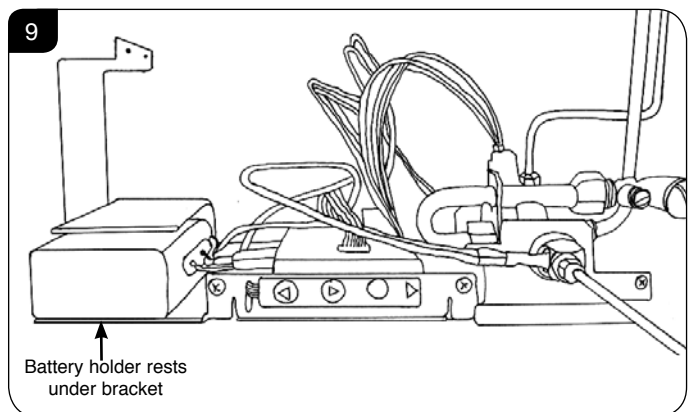

- 6.2 Slide the lid off the top of the battery holder and remove the old batteries.  
6.3 Correctly position the three new C Cell size batteries into the battery holder as shown in Diagram 10.

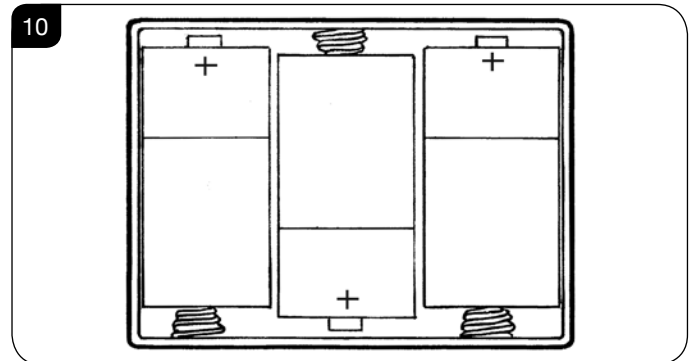

Refit the lid of the battery box and replace into position.

**PLEASE ENSURE NO WIRES ARE TRAPPED BEFORE REPLACING THE LOWER PANEL. THE TOUCH PAD LEAD IS EASILY DAMAGED**

## 7. Cleaning the Appliance

**IMPORTANT: THE OUTER PANNELLING OF THE RIVA VISION IS MADE FROM GLASS. USE CAUTION WHEN INSTALLING, REMOVING AND STORING AS THE COMPONENTS ARE FRAGILE AND COULD BREAK UNLESS HANDLED CAREFULLY.**

- 7.1 Make sure the appliance and surrounds are cool before cleaning.  
Use:  
– A dry cloth to clean the appliance casing.  
– A damp cloth for the glass front.

### 7.2 All Models

Remove the plinth to access the touchpad and battery box by lifting the hooks clear of the slots on the front of the appliance, see Diagram 10.

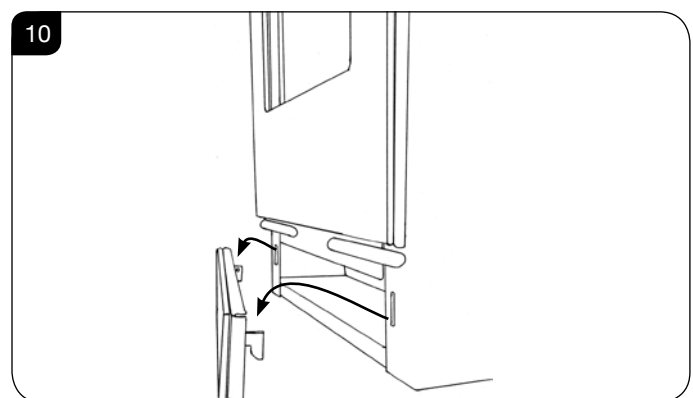

- 7.3 Remove the frame to gain complete access to the control box and the viewing aperture by lifting the hooks clear of the slots on the front of the appliance, see Diagram 11.

# User Instructions

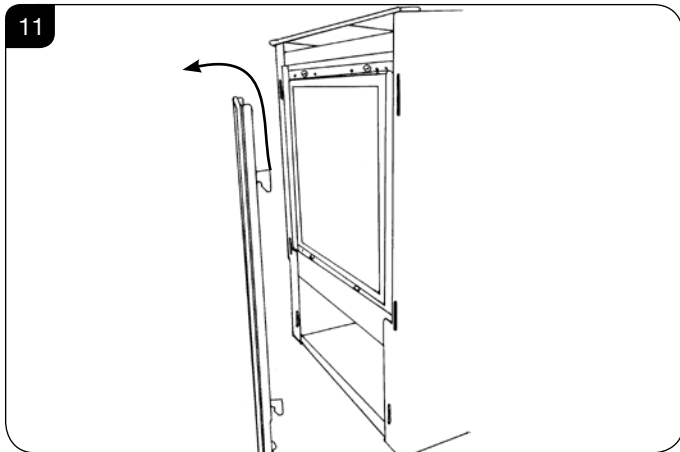

## 7.4 Small and Midi only:

Using screwdriver remove the 6 screws securing the window panel to the appliance, see Diagram 12, Arrows A. Take care to support the glass when removing the screws.

## 7.5 Medium only:

Using screwdriver remove the 8 screws, securing the window panel to the appliance, see Diagram 12, Arrows A & B. Take care to support the glass when removing the screws.

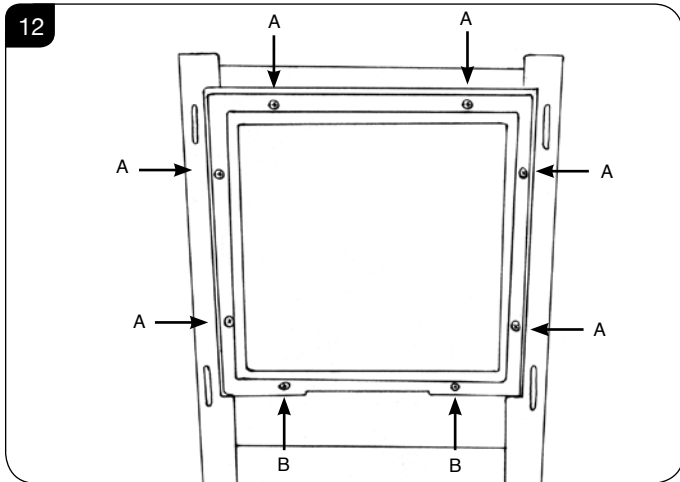

7.5 The glass frame must be refitted to the appliance following cleaning or servicing. Hold in position and secure with the screws

7.6 Replace ALL of the securing screws ensuring that a screw is present in all fixing slots.



**UNDER NO CIRCUMSTANCES SHOULD THE APPLIANCE BE USED IF ANY OF THE GLASS FRAME RETAINING SCREWS ARE LOOSE OR MISSING.**

## 8. Arrangement of Fuel Bed

### Advice on handling and disposal of fire ceramics



The fuel effect of the log version of this appliance is made from Refractory Ceramic Fibre (RCF), a material which is commonly used for this application.

Protective clothing is not required when handling these articles, but we recommend you follow normal hygiene rules of not smoking, eating or drinking in the work area and always wash your hands before eating or drinking.

To ensure that the release of RCF fibres are kept to a minimum, during installation and servicing a HEPA filtered vacuum is recommended to remove any dust accumulated in and around the appliance before and after working on it. When servicing the appliance it is recommended that the replaced items are not broken up, but are sealed within heavy duty polythene bags and labelled as RCF waste.

RCF waste is classed as stable, non-reactive hazardous waste and may be disposed of at a licensed landfill site.

Excessive exposure to these materials may cause temporary irritation to eyes, skin and respiratory tract; wash hands thoroughly after handling the material.

## 9. Log Layout

**LOGS MUST BE POSITIONED ACCORDING TO THE FOLLOWING INSTRUCTIONS TO GIVE THE CORRECT FLAME EFFECT**

### Small Vision Layout

9.1 Ensure the burner tray is clean and free from any debris, see Diagram 13.



The three logs that make up the fuel bed are visually distinct and fit into specific parts on the burner tray.

# User Instructions

- 9.2 Place the rear log into position, see Diagram 14. Ensure that the left hand edge butts up against the raised groove in the burner tray and the back panel- see Detail A.

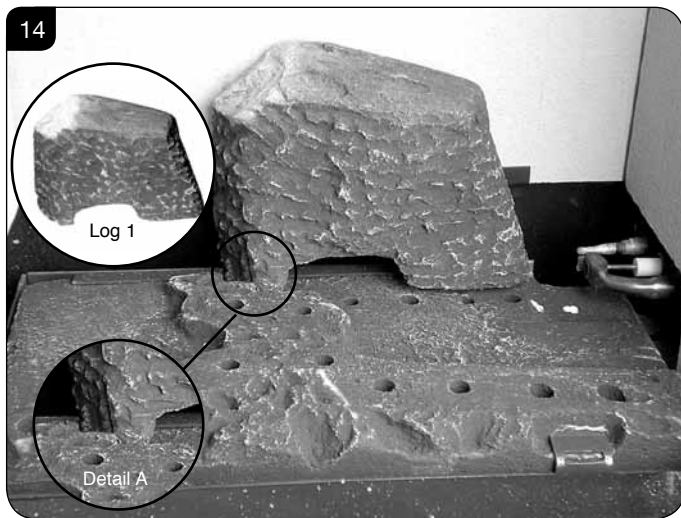

- 9.3 Place the second log into the left hand groove on the burner tray and ensure it is pushed as far into the centre as the groove will allow, see Diagram 15.

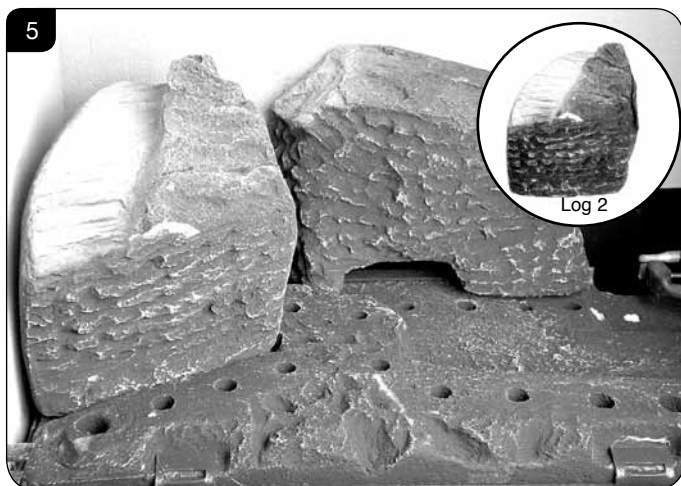

- 9.4 Place the third log into the groove on the right hand side and ensure it is pushed as far into the centre as the groove will allow, see Diagram 16.

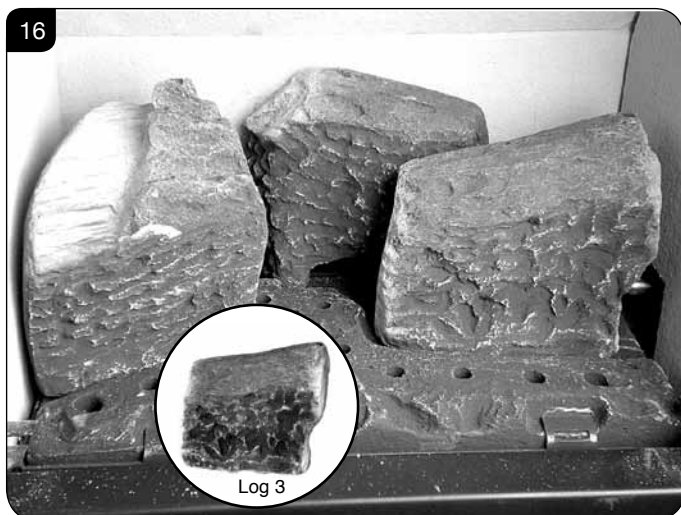

- 9.5 Once the logs are in place use some of the Embaglow wire wool provided and cover the ports in the burner tray with a liberal amount of fibres, see Diagram 17.  
NOTE: It is not necessary to use all of the Embaglow.

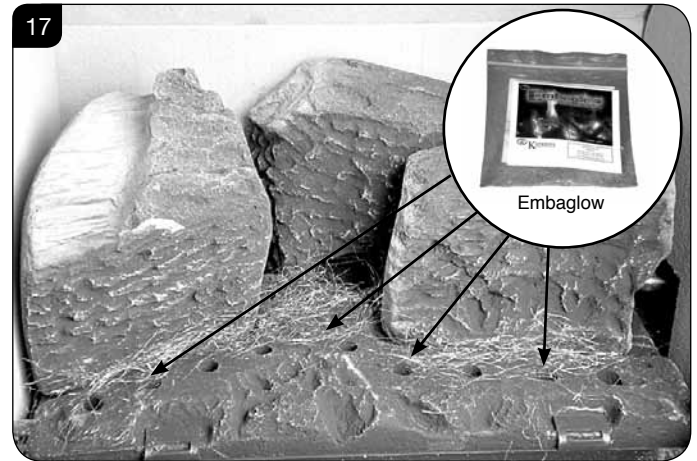

- 9.6 Fix log guard into position, see Diagram 18.

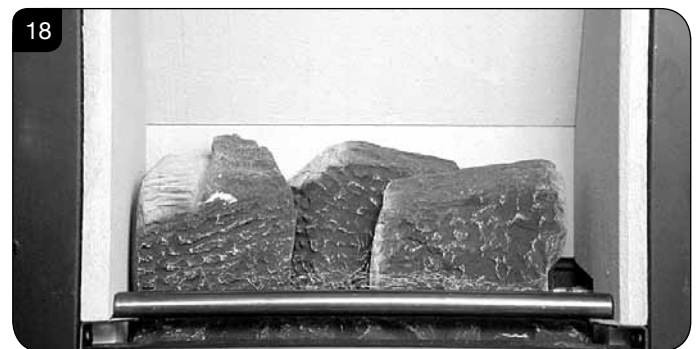

## Midi Vision Layout

- 9.7 Ensure the burner tray is clean and free from any debris, see Diagram 19.

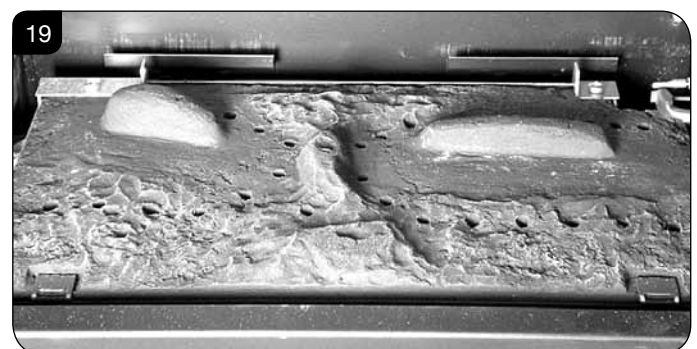

The three logs that make up the fuel bed are visually distinct and fit into specific parts on the burner tray.

- 9.8 Place the rear log into position between the rear brackets and pushed up against the back panel, see Diagram 20.

# User Instructions

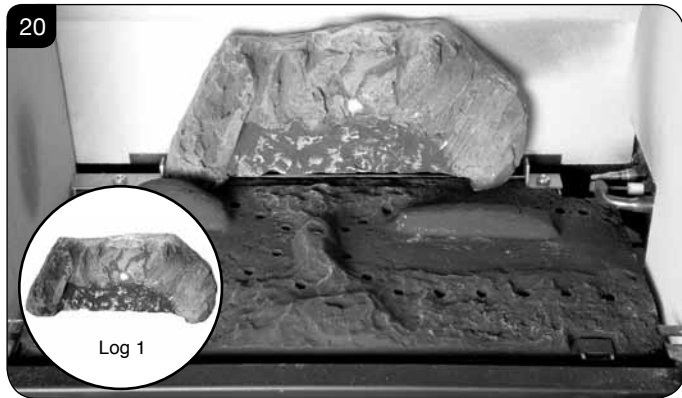

- 9.9 Place the second log into the left hand groove on the burner tray, see Diagram 21. The log should butt up against the raised molding and the left hand side liner.

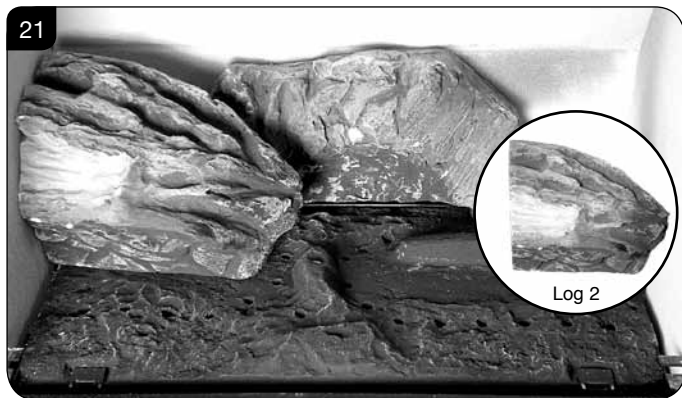

- 9.10 Place the third log into the groove on the right hand side, see Diagram 22. The log should butt up against the raised molding and the right hand side liner.

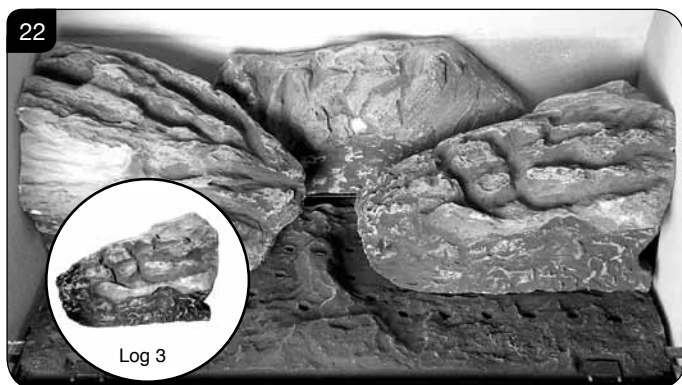

- 9.11 Once the logs are in there are two embers which can be loosely placed at the front of the fuel bed and cover the tabs securing the burner tray, see Diagram 23.

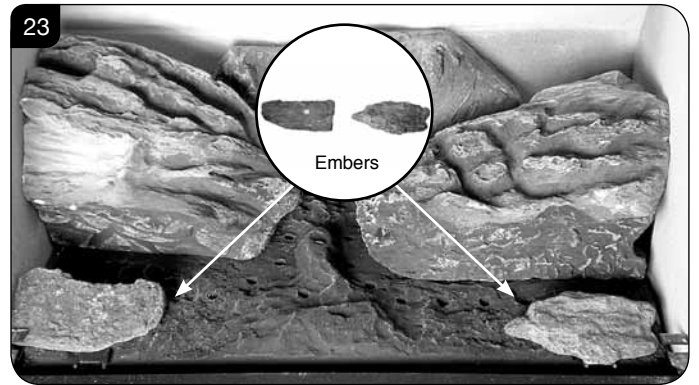

- 9.12 Use some of the Embaglow provided and cover the ports in the burner tray with a liberal amount of fibres, see Diagram 24.

**It is essential to cover the port in the middle of the burner tray in order to get the most visually appealing flame picture.**

NOTE: It is not necessary to use all of the Embaglow.

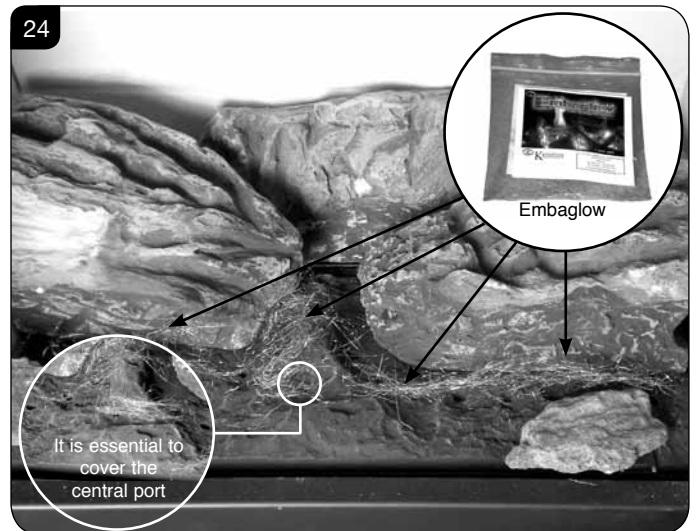

- 9.13 Fix log guard into position, see Diagram 25.

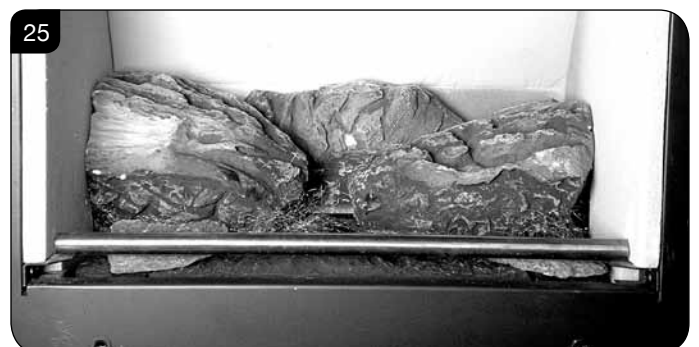

# User Instructions

## Medium Vision Layout

The logs for the fuel bed are clearly individually labelled, A to D.

- 9.14 Ensure the burner tray is clean and free from any debris, see Diagram 26.

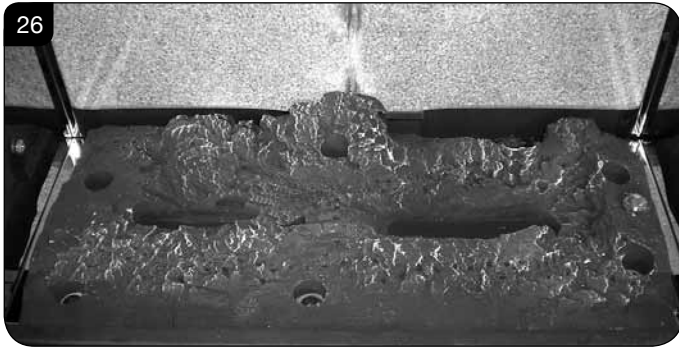

- 9.15 There are 3 embers. Place 2 embers in the back corners of the burner, resting in the cut outs, see Diagram 27. Place the last ember loosely at the front of the fuel bed to cover the hole in the centre.

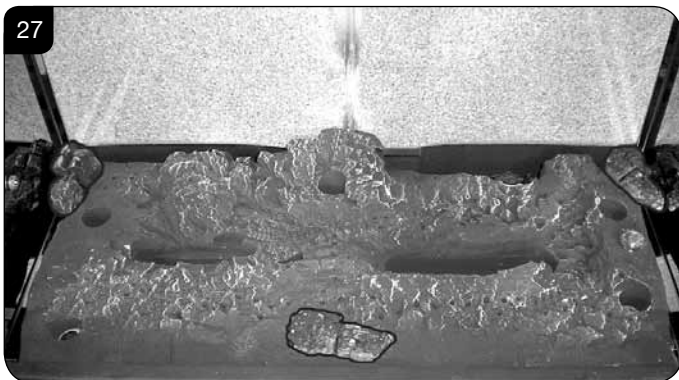

- 9.16 Place Log D on the left hand side of the burner. There is a hole on the underside of Log D which fits over the raised stud on the left of the burner. The back of the log should rest flat against the back panel, see Diagram 28.

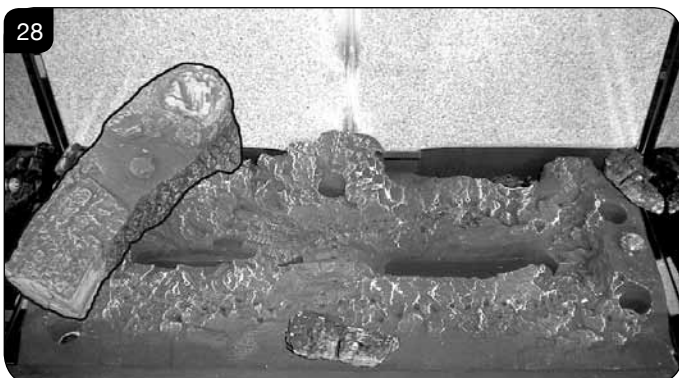

- 9.17 Place Log B on top of Log D. There is a hole on the underside of Log B which fits over the raised stud on Log D to secure in place. The right hand side of the log rests in the groove in the burner, see Diagram 29.

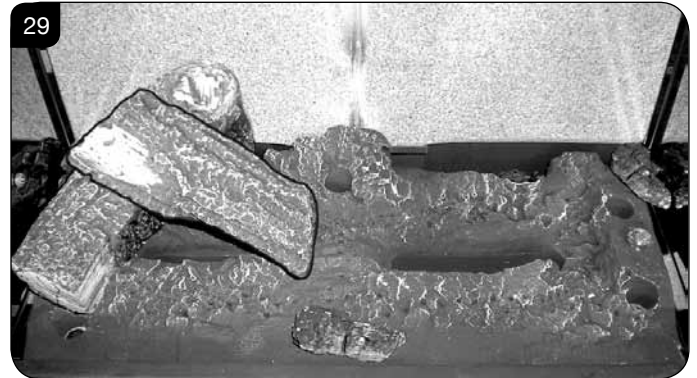

- 9.18 Place Log C on the right hand side of the burner. There is a hole on the underside of Log C which fits over the raised stud on the right of the burner. The back of the log should rest flush against the back panel, see Diagram 30.

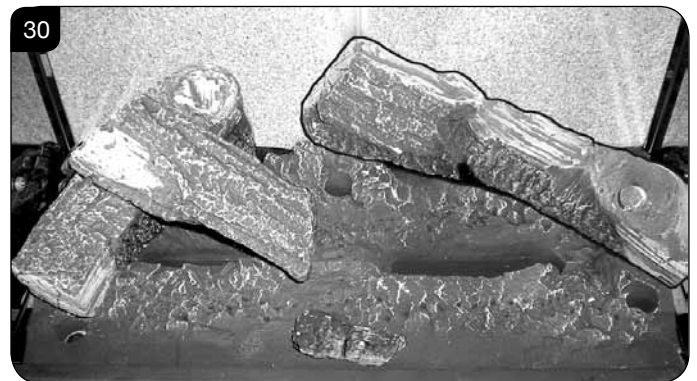

- 9.19 Place the log guard into position on the grooves on the sides of the firebox, see Diagram 31.



# User Instructions

- 9.20 Place Log A across Log C. There is a hole on the underside of Log A which fits over the raised stud on Log C to secure in place. The small cut out on the left side of the log rests onto the log guard, see Diagram 32.



- 9.21 Once the logs are in place use some of the Embaglow wire wool provided and cover the ports in the burner tray with a liberal amount of fibres, in the highlighted areas shown in Diagram 33.

NOTE: It is not necessary to use all of the Embaglow.



## 10. Flame Failure Device

- 10.1 This is a safety feature incorporated on this appliance which automatically switches off the gas supply if the pilot goes out and fails to heat the thermocouple.

**IF THIS OCCURS DO NOT ATTEMPT TO RELIGHT THE APPLIANCE FOR 3 MINUTES.**

## 11. Running In

- 11.1 During initial use of a new Gazco appliance a strong odour will be encountered as various surface coatings become hot for the first time. Although these odours are harmless it is recommended that the appliance is operated on maximum for 4 to 8 hours in order to fully burn off these coatings. After this period the odours should then disappear.

If the odours persists, please contact your installer for advice.

- 11.2 During the first few hours of burning there may be discolouration of the flames. This will also disappear after a short period of use.

## 12. Servicing

- 12.1 The appliance must be serviced every 12 months by a qualified Gas Engineer. In all correspondence always quote the Model number and the Serial number which may be found on the data badge.

## 13. Ventilation

- 13.1 Any purpose provided ventilation should be checked periodically to ensure that it is free from obstruction.

## 14. Installation Details

- 14.1 Your installer should have completed the commissioning sheet at the front of this book. This records the essential installation details of the appliance. In all correspondence always quote the Model number and Serial number.

## 15. Hot Surfaces

- 15.1 Parts of this appliance become hot during normal use.
- 15.2 Provide a suitable fire guard to protect young children and the infirm.

## 16. Appliance will not light

- 16.1 If you cannot light the appliance:
- Check and change the batteries in the remote handset.
  - Check and change the appliance batteries, **Section 6**.

Consult your Gazco retailer if the appliance still does not light.

# Installation Instructions

## Technical Specification

Covering the following models:

Model	NATURAL GAS		LPG	
	Top Exit	Rear Exit	Top Exit	Rear Exit
Riva Vision Small	526-166	526-192	526-548	526-710
Riva Vision Midi	526-393	526-313	526-570	526-746
Riva Vision Medium	526-198	526-243	526-469	526-402

Model	Gas CAT.	Gas Type	Working Pressure	Aeration	Injector	Gas Rate m <sup>3</sup> /h	Input kW (Gross)		Country
							High	Low	
Riva Vision Small CF	I <sub>2</sub> H	Natural (G20)	20mbar	6mm Ø	190	0.324	3.4	2.3	GB, IE
	I <sub>3</sub> P	Propane (G31)	37mbar	One side open 1 x (9 x 15 offset)	90	0.120	3.2	2	GB, IE
Riva Vision Midi CF	I <sub>2</sub> H	Natural (G20)	20mbar	6 x 6	260	0.433	4.55	2.5	GB, IE
	I <sub>3</sub> P	Propane (G31)	37mbar	One side open 1 x (14 x 15)	102	0.164	4.35	2.5	GB, IE
Riva Vision Medium CF	I <sub>2</sub> H	Natural (G20)	20mbar	2 x 6mm Ø	067	0.629	6.6	3.9	GB, IE
	I <sub>3</sub> P	Propane (G31)	37mbar	2 x 13mm Ø	128	0.252	6.7	3.7	GB, IE
<b>Efficiency Class 2 - 75% Net/ NOx Class 4</b>									
Flue Size TOP/REAR EXIT 127mm ø									
Gas Inlet Connection Size = 8mm ø									
Minimum Flue Specification = T260/N2/O/D/1									
Maximum Flue Temp = 220°C									

**i** The net efficiency of this appliance has been measured as specified in EN613:2001 and the result after conversion to gross using the appropriate factor from Table E4 of SAP 2009 is 67.6%. The test data has been certified by Kiwa Nederand BV. The gross efficiency value may be used in the UK Government's Standard Assessment Procedure (SAP) for energy rating of dwellings.

# Installation Instructions

## Technical Specification

This appliance has been certified for use in countries other than those stated. To install this appliance in these countries, it is essential to obtain the translated instructions and in some cases the appliance will require modification. Contact Gazco for further information.

### PACKING CHECKLIST

Qty Description	Fixing Kit containing:-
For Log Layout	1 x Instruction Manual
1 Log Set	2 x Wood Screws
1 x Packet of Embaglow	2 x Rawl Plugs
	1 x Handset
	3 x C cell batteries
	2 x AA batteries
	2 x Self Tapping Screws
	2 x Wingnuts
	1 x Fixing Plate
	2 x Washers

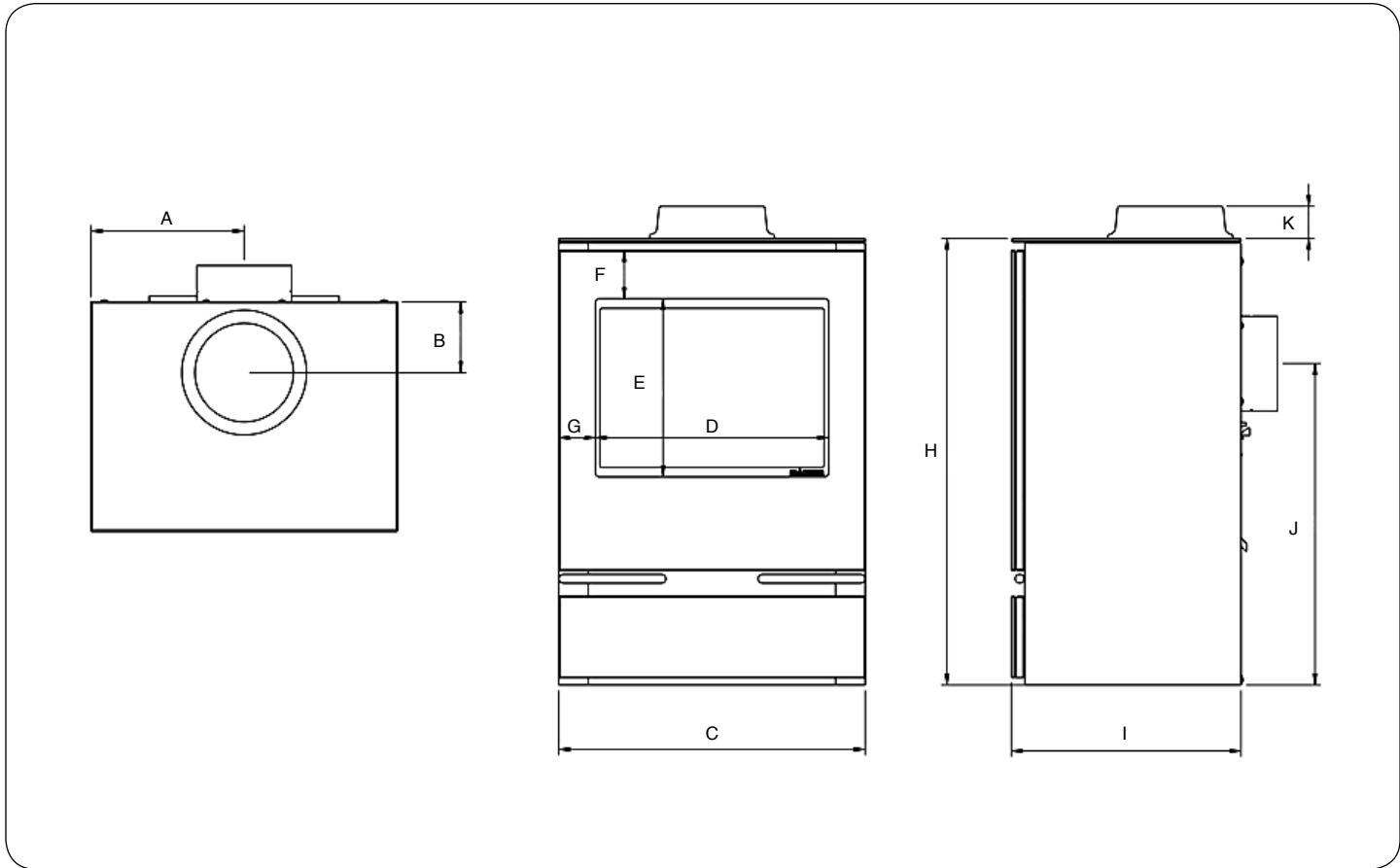

Model	A	B	C	D	E	F	G	H	I	J	K
Riva Vision Small	185	97	370	254	240	56	58	529	289	359	43
Riva Vision MIDI	208	96	415	316	241	65	50	605	311	436	43
Riva Vision Medium	268	110	535	408	274	77	64	677	353	537	69



# Installation Instructions

## Site Requirements

### 1. Flue & Chimney Requirements

- 1.1 The chimney or flue system must comply with the rules in force, and must be a minimum of 127mm in diameter. (5").
- 1.2 The minimum flue height for the appliance must be 3 metres (10ft). Any horizontal flue run from the rear outlet must not exceed 100mm from the back of the appliance.
- 1.3 The chimney or flue must be free from any obstruction. Any damper plates must be removed or secured in the fully open position, and no restrictor plates fitted.
- 1.4 The chimney must be swept prior to the installation, but it need not be swept if it can be seen the chimney is clean and unobstructed throughout its entire length.
- 1.5 A5" (127mm) liner must be used if fitting the appliance into an existing brick built chimney. Larger lined flues can work, but in some instances could cause cold start flue problems resulting in nuisance shutdown. Lined flues above 7" (175mm) are not recommended.
- 1.6 Due to European chimney standards, new flue's and chimney's are described by their temperature, pressure and resistance to corrosion, condensation and fire. To assist in identifying the correct flue system, the minimum flue specification is shown in the Technical Specification. Existing chimneys are not covered by this system.

### 2. Flue Options

- 2.1 Consult the rules in force.

NOTE: This appliance does not normally require any additional ventilation when installed in GB.

**A range of Vitreous Enamel Gloss Black flue pipe is available to compliment the Riva Vision. Please contact your Gazco retailer for further information.**

### 3. Gas Supply

**THIS APPLIANCE IS INTENDED FOR USE ON A GAS INSTALLATION WITH A GOVERNED METER.**

- 3.1 Before installation, ensure that the local distribution conditions (identification of the type of gas and pressure) and the adjustment of the appliance are compatible.
- 3.2 Ensure the gas supply delivers the required amount of gas and is in accordance with the rules in force.
- 3.3 You can use soft copper tubing on the installation and soft soldered joints outside the appliance and below the fire.
- 3.4 A factory fitted isolation device is part of the inlet connection; no further isolation device is required.

- 3.5 All supply gas pipes must be purged of any debris that may have entered prior to connection to the appliance.
- 3.6 The gas supply enters through the rear of the LEFT-HAND side of the outer box:
- 3.7 The gas supply must be installed in a way that does not restrict the removal of the appliance for servicing and inspection.

### 4. Ventilation

**IMPORTANT: Ensure any national ventilation requirements are taken into account during installation of the appliance.**

**UK ONLY:**

The Riva Vision has a nominal input not exceeding 7.0kW and does not normally require any additional permanent ventilation.

**FOR THE REPUBLIC OF IRELAND REFER TO THE RULES IN FORCE FOR VENTILATION REQUIREMENTS.**

### 5. Appliance Location

- 5.1 This appliance has been designed to stand on either a hearth or an optional bench:  
RVACLB100B - Riva Bench Low (100cm wide)  
RVACB100B - Riva Bench (100cm wide)  
RVACLB120B - Riva Bench Low (120cm wide)  
RVACB120B - Riva Bench (120cm wide)  
RVACLB140B - Riva Bench Low (140cm wide)  
RVACB140B - Riva Bench (140cm wide)
- 5.2 **To install the Bench:**  
Follow Section 1 Installation - All Models in Installation guide PM205 supplied with the bench kit.
- 5.3 **To secure the appliance to the bench:**  
You must consider where you place the appliance on the bench before drilling the bench, see Diagram 1.

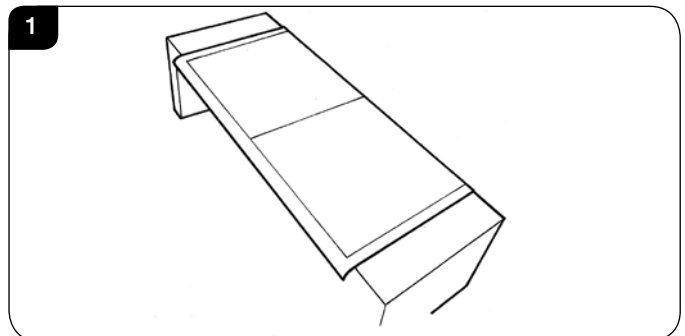

**Once the position of the appliance has been decided:**  
Follow the instructions for securing the appliance on Page 19.

# Installation Instructions

## Site Requirements

- 5.4 The non-combustible hearth must be at least 12mm thick, and project a minimum of 50mm from the base of the appliance in all directions.
- 5.5 The appliance is not suitable for installation against a combustible wall. A combustible side wall must be a minimum of 150mm from the appliance.
- 5.6 This appliance can be installed with an up and out flue (vertical wall - horizontal flue) or with a vertical flue with roof termination (see **Flue Options, Section 2 Site Requirements**).

### HEARTH INSTALLATION

- 5.7 Building Regulations state this appliance must stand on a non-combustible hearth that is at least 12mm thick and projects 50mm minimum from the base of the appliance in all directions, however Gazco recommend the hearth extends to the following dimensions, see Diagram 9.

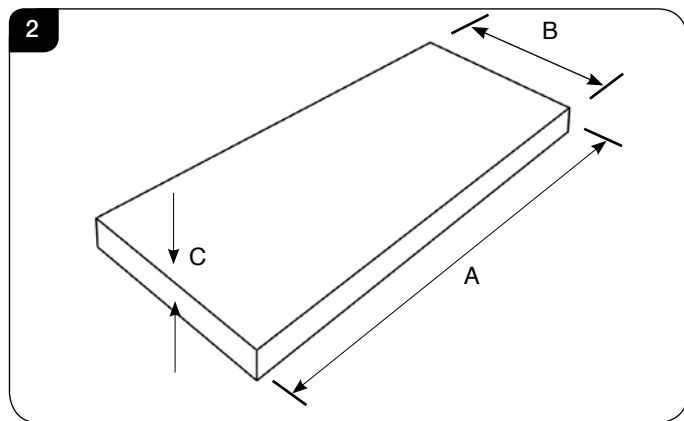

Dimensions	Small	Midi	Medium
A	670mm	715mm	835
B	390mm	410mm	453
C	12mm	12mm	12mm

### MINIMUM CLEARANCE

- 5.8 The appliance is not suitable for installation against a combustible wall. All combustible materials must be removed from behind the appliance.
- 5.9 **Ensure that all minimum clearances to combustible materials are complied with, see Diagrams 3 & 4.**

The specified clearances provide the minimum distance to combustible materials. If the appliance is intended to be installed into a non-combustible opening the clearance to the **sides and above** the appliance can be reduced. However, it is recommended that the specified clearances are maintained irrespective of the materials used in the construction of the opening to allow adequate air flow and access to controls. **The clearance at the rear of the appliance must always be a minimum of 50mm.**

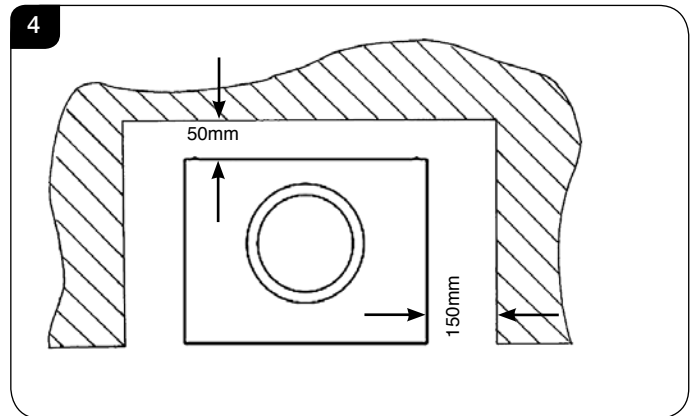
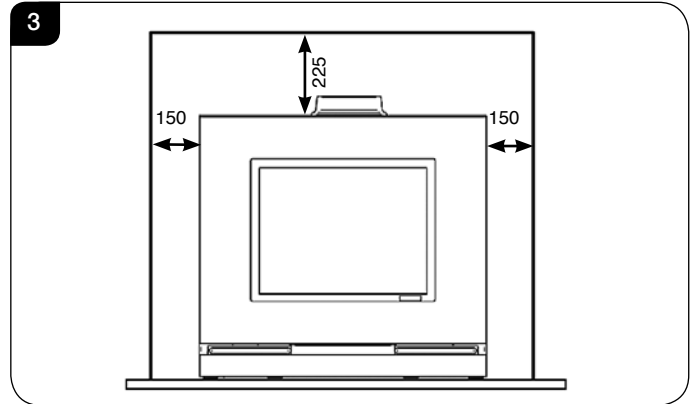

- 5.10 The above dimensions provide adequate clearance to combustible materials. It may be necessary to add additional clearance so that spillage tests can be performed when necessary.

# Installation Instructions

## 1. Safety Precautions

- 1.1 For your own and other's safety, you must install this appliance according to local and national codes of practice. Failure to install the appliance correctly could lead to prosecution. **Read these instructions before installing and using this appliance.**
- 1.2 These instructions must be left intact with the user.
- 1.3 Do not attempt to burn rubbish on this appliance.
- 1.4 Keep all plastic bags away from young children.
- 1.5 Do not place any object on or near to the appliance and allow adequate clearance above the appliance.

**IF THE APPLIANCE IS EXTINGUISHED OR GOES OUT IN USE, WAIT 3 MINUTES BEFORE ATTEMPTING TO RELIGHT THE APPLIANCE.**



**IMPORTANT: REFER TO DATA BADGE AND TECHNICAL SPECIFICATION AT THE FRONT OF THE MANUAL TO ENSURE THE APPLIANCE IS CORRECTLY ADJUSTED FOR THE GAS TYPE AND CATEGORY APPLICABLE IN THE COUNTRY OF USE.**

**FOR DETAILS OF CHANGING BETWEEN GAS TYPES REFER TO SERVICING, SECTION 15, REPLACING PARTS.**

## Unpacking

- 1.6 Remove the appliance from its packaging, and check that it is complete and undamaged.
- 1.7 The glass lid is stored on top of the appliance. Remove and store in a safe place.

Put the loose ceramic parts to one side so that they are not damaged during installation.

## 2. Installation of the Appliance



**IMPORTANT: THE OUTER PANELLING OF THE RIVA VISION IS MADE FROM GLASS. USE CAUTION WHEN INSTALLING, REMOVING AND STORING AS THE COMPONENTS ARE FRAGILE AND COULD BREAK UNLESS HANDLED CAREFULLY.**



**Please note: As an optional extra Gazco can provide a mains adapter to supply constant power to the appliance control box instead of the battery pack.**

**If installing an appliance with the adapter make provision for a mains power socket within 1.5m of the control box and follow the instructions provided.**

### 2.1 All Models

Remove the plinth to access the touchpad and battery box by lifting the hooks clear of the slots on the front of the appliance, see Diagram 1.

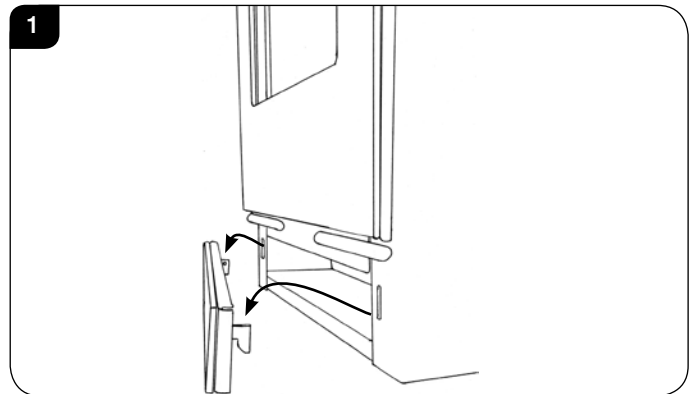

- 2.2 Remove the frame to gain complete access to the control box and the viewing aperture by lifting the hooks clear of the slots on the front of the appliance, see Diagram 2.

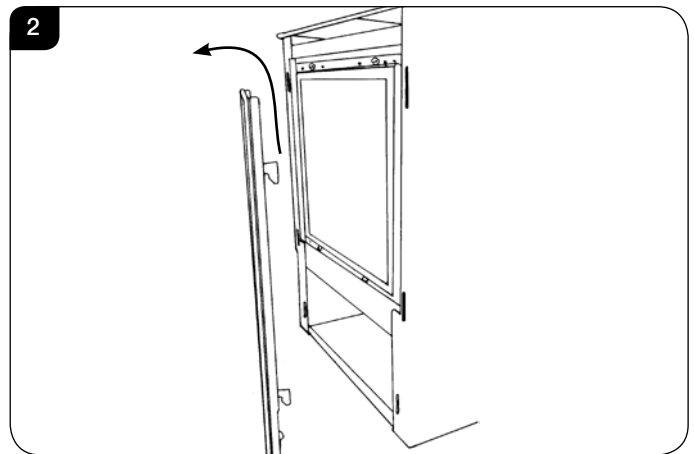

## Small & Midi only

### SECURING THE APPLIANCE

**The appliance sits on a mounting bracket to secure it in place to either the hearth or bench.**

- 2.3 Position the appliance:  
Loosely attach the bracket to the appliance and place centrally on the hearth OR in the desired position on the bench. Remove the appliance leaving the bracket in the correct position and mark the holes to drill the bracket screws, see Diagram 3.

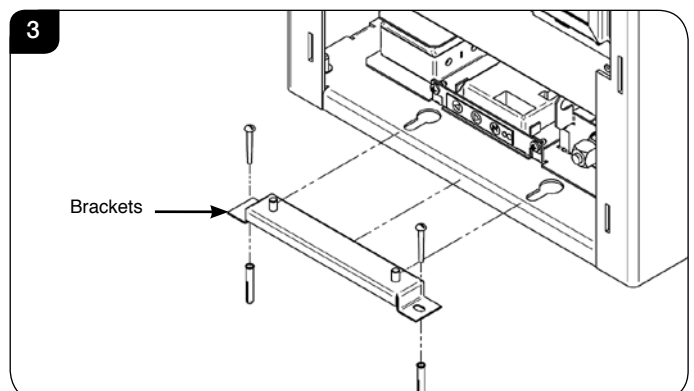

- 2.4 Remove the bracket and drill the guide holes.

# Installation Instructions

- 2.5 Fix the bracket either to the hearth or the bench, see Diagram 3.

**NOTE: Use the wood screws and rawl plugs in the fixing kit supplied for hearth mounting installations and the self tapping screws for installation onto a bench.**

- 2.6 Lift the appliance so as to locate the key slots onto the fixing screws. There are two large holes the lower flanges on the front edges of the base, see Diagram 4.

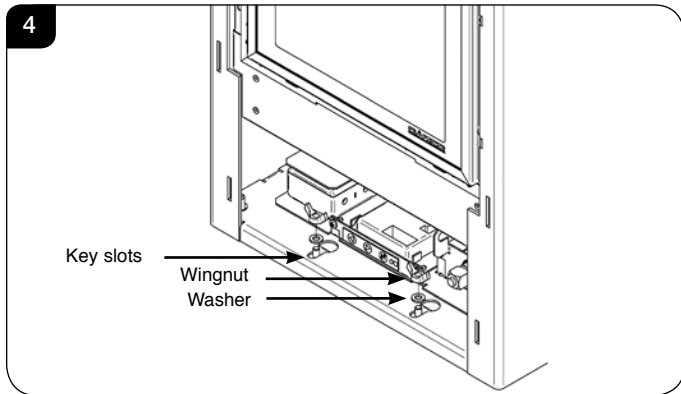

- 2.7 Place the two large washers over the studs and fix with two wingnuts, see Diagram 4.

## 3. Fitting the Top Plate

- 3.1 The Riva Vision has a decorative plate that sits on top of the outer box. Depending on the choice of flue exit this top will have a hole for the flue pipe to pass through or be completely smooth.

The hole will be situated in an off set position to the rear edge of the cast top.

When installing the spigot must be put in place before the cast top is located. Then the connection to the flue can be made.

**NOTE: For Top Exit appliances the flue collar must be placed on the flue exit before the top is fitted.**

- 3.2 To fit the top line up the raised fins on the underside of the glass plate with the cut outs in the top of the box, see Diagram 5a & 5b.

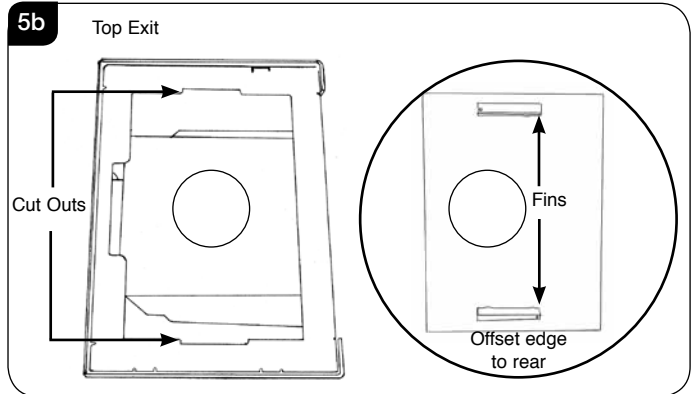
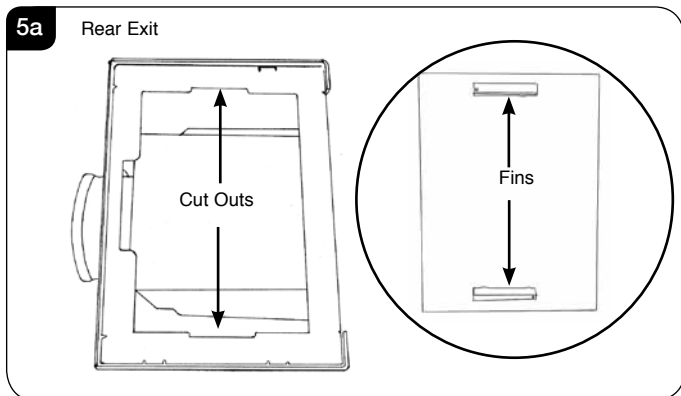

- 3.3 When properly fitted the rear of the glass plate should sit flush with the rear of the appliance, see Diagram 6.

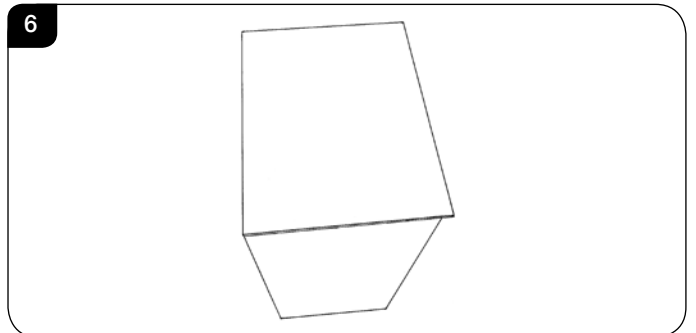

## 4. Gas Soundness Pressure Check

- 4.1 Connect a suitable pressure gauge to the test point located on the inlet fitting and turn the gas supply on. Light the appliance and check all gas joints for possible leaks. Turn the appliance to maximum and check that the supply pressure is as stated on the databadge. Turn the gas off and replace the test point screw, turn the gas on and check the test point for leaks.

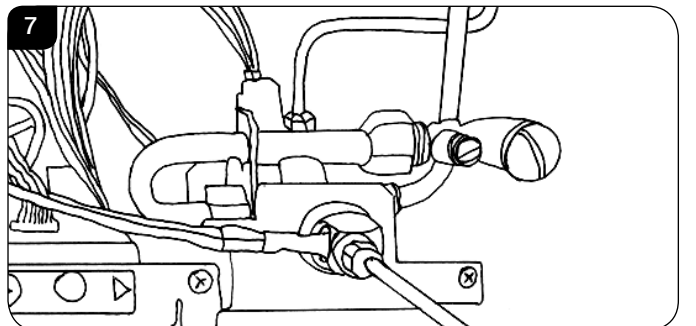

# Installation Instructions

## 5. Removing the Glass

- 5.1 **Small and Midi only:**  
Using screwdriver remove the 6 screws securing the window panel to the appliance, see Diagram 8, Arrows A.
- 5.2 **Medium only:**  
Using screwdriver remove the 8 screws, securing the window panel to the appliance, see Diagram 8, Arrows A & B.

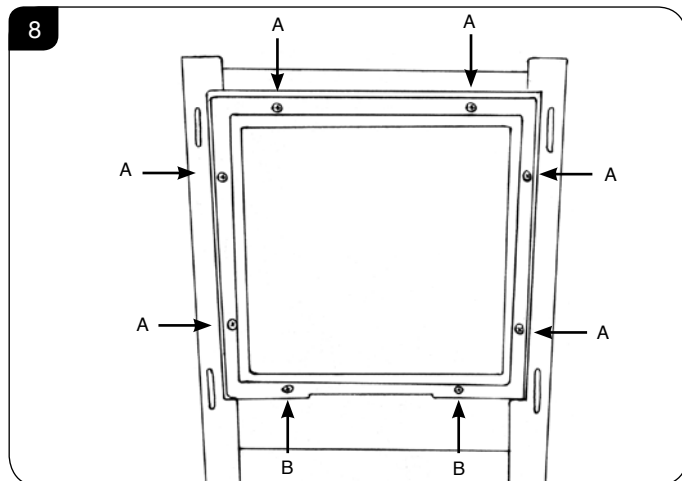

Take care to support the glass when removing the screws.

## 6. Arrangement of the Fuel Bed

### Advice on handling and disposal of fire ceramics



The fuel effect of the log version of this appliance is made from Refractory Ceramic Fibre (RCF), a material which is commonly used for this application.

Protective clothing is not required when handling these articles, but we recommend you follow normal hygiene rules of not smoking, eating or drinking in the work area and always wash your hands before eating or drinking.

To ensure that the release of RCF fibres are kept to a minimum, during installation and servicing a HEPA filtered vacuum is recommended to remove any dust accumulated in and around the appliance before and after working on it. When servicing the appliance it is recommended that the replaced items are not broken up, but are sealed within heavy duty polythene bags and labelled as RCF waste.

RCF waste is classed as stable, non-reactive hazardous waste and may be disposed of at a licensed landfill site.

Excessive exposure to these materials may cause temporary irritation to eyes, skin and respiratory tract; wash hands thoroughly after handling the material.

## 7. Log Layout

**LOGS MUST BE POSITIONED ACCORDING TO THE FOLLOWING INSTRUCTIONS TO GIVE THE CORRECT FLAME EFFECT**

### Small Vision Layout

- 7.1 Ensure the burner tray is clean and free from any debris, see Diagram 9.



The three logs that make up the fuel bed are visually distinct and fit into specific parts on the burner tray.

- 7.2 Place the rear log into position, see Diagram 10. Ensure that the left hand edge butts up against the raised groove in the burner tray and the back panel- see Detail A.

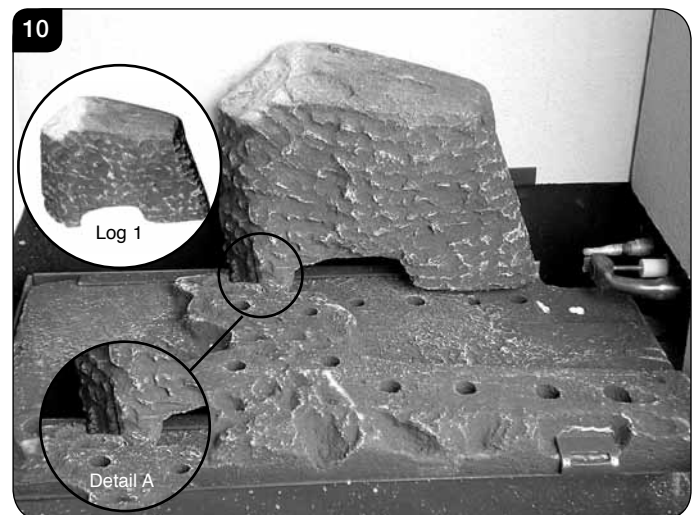

- 7.3 Place the second log into the left hand groove on the burner tray and ensure it is pushed as far into the centre as the groove will allow, see Diagram 11.

# Installation Instructions

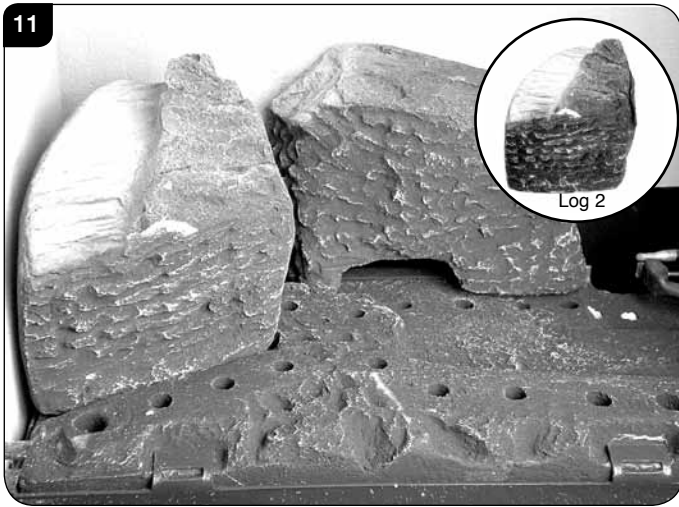

7.4 Place the third log into the groove on the right hand side and ensure it is pushed as far into the centre as the groove will allow, see Diagram 12.

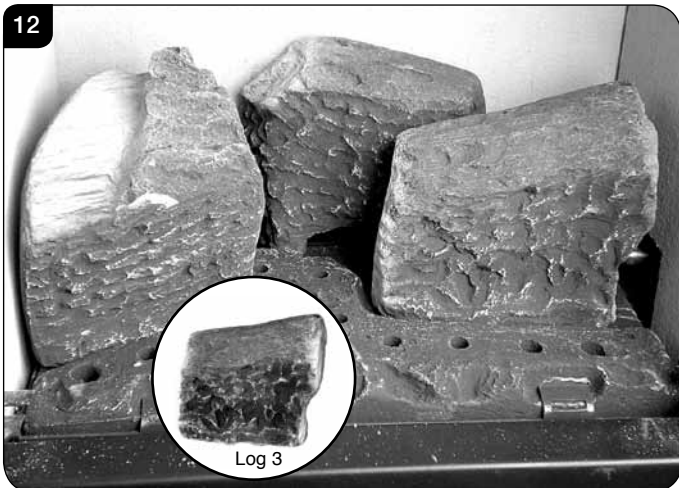

7.5 Once the logs are in place use some of the Embaglow wire wool provided and cover the ports in the burner tray with a liberal amount of fibres, see Diagram 13.

NOTE: It is not necessary to use all of the Embaglow.

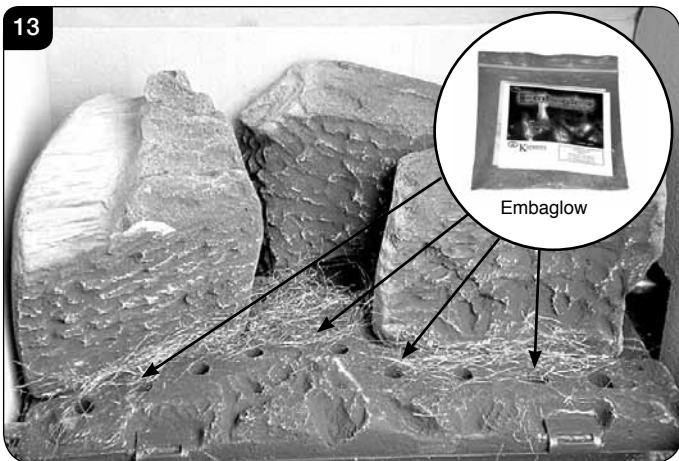

7.6 Fix log guard into position, see Diagram 14.

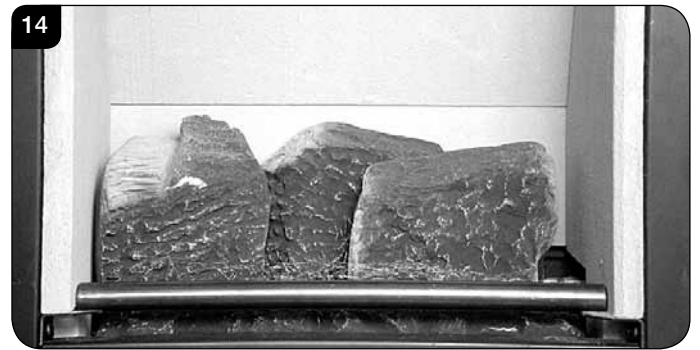

## Midi Vision Layout

7.7 Ensure the burner tray is clean and free from any debris, see Diagram 15.



The three logs that make up the fuel bed are visually distinct and fit into specific parts on the burner tray.

7.8 Place the rear log into position between the rear brackets and pushed up against the back panel, see Diagram 16.

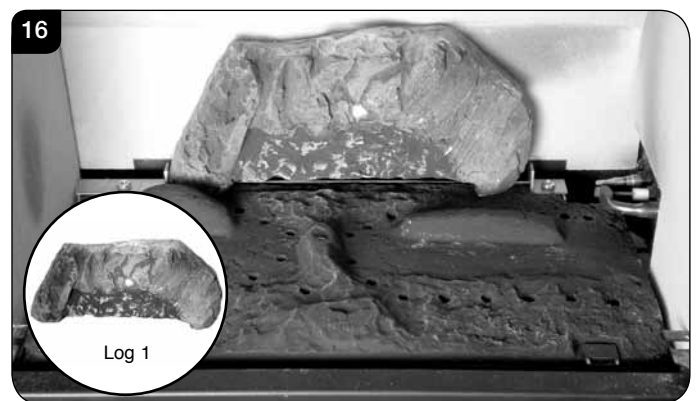

7.9 Place the second log into the left hand groove on the burner tray, see Diagram 17. The log should butt up against the raised molding and the left hand side liner.

# Installation Instructions

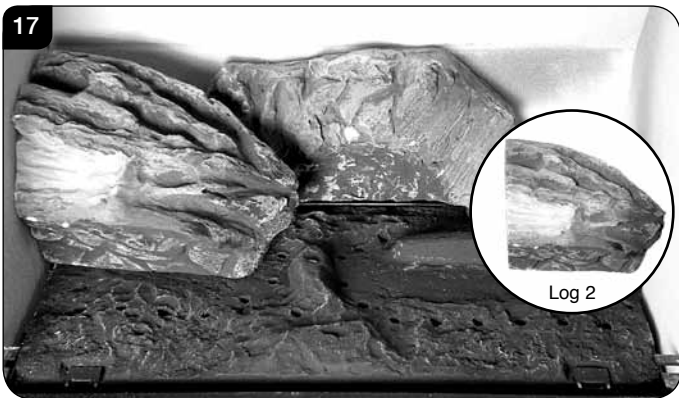

7.10 Place the third log into the groove on the right hand side, see Diagram 18. The log should butt up against the raised molding and the right hand side liner.

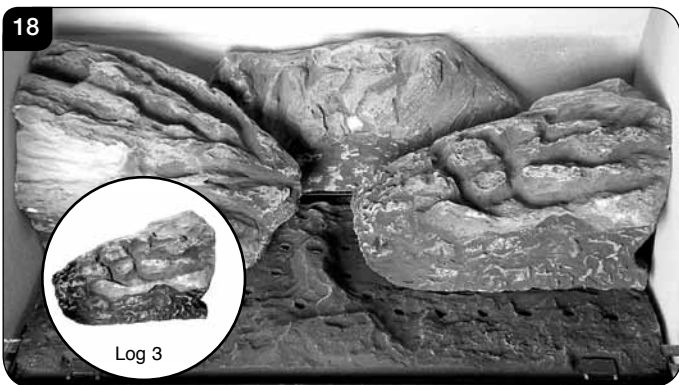

7.11 Once the logs are in there are two embers which can be loosely placed at the front of the fuel bed and cover the tabs securing the burner tray, see Diagram 19.

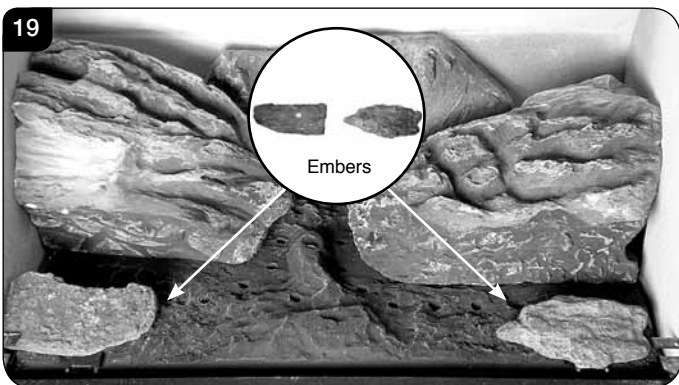

7.12 Use some of the Embaglow provided and cover the ports in the burner tray with a liberal amount of fibres, see Diagram 20.

**It is essential to cover the port in the middle of the burner tray in order to get the most visually appealing flame picture.**

NOTE: It is not necessary to use all of the Embaglow.

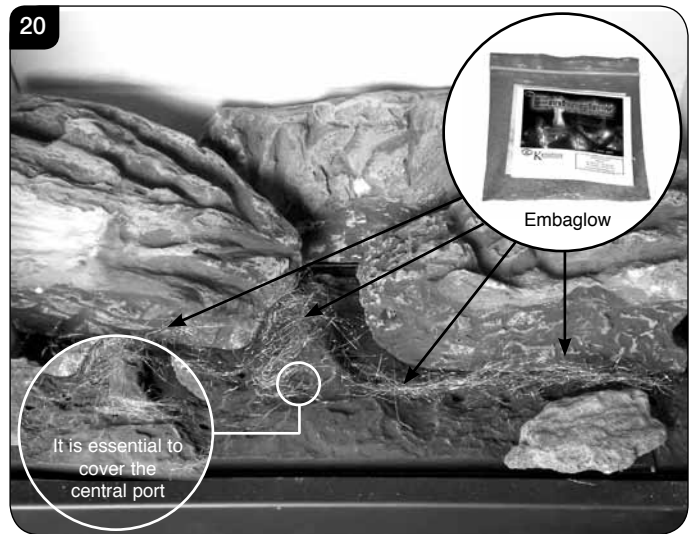

7.13 Fix log guard into position, see Diagram 21.

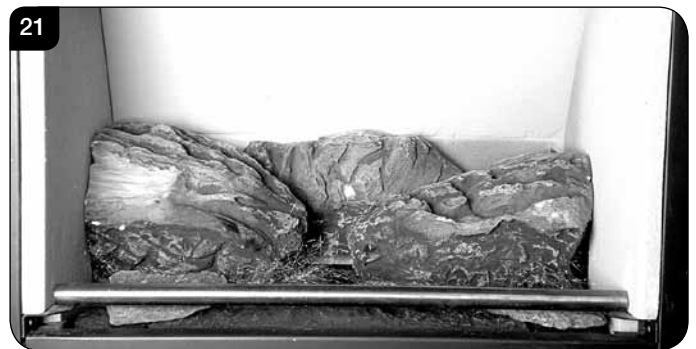

## Medium Vision Layout

The logs for the fuel bed are clearly individually labelled, A to D.

7.14 Ensure the burner tray is clean and free from any debris, see Diagram 22.

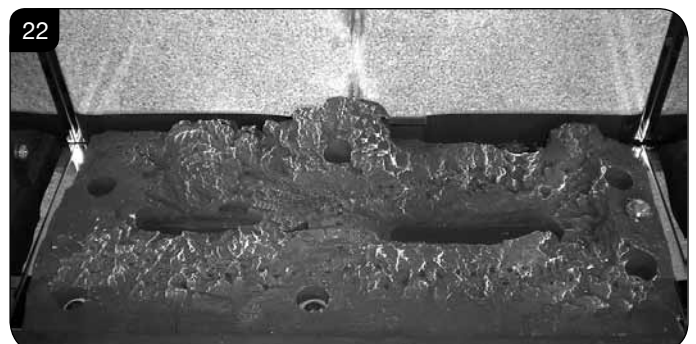

# Installation Instructions

- 7.15 There are 3 embers. Place 2 embers in the back corners of the burner, resting in the cut outs, see Diagram 23. Place the last ember loosely at the front of the fuel bed to cover the hole in the centre.

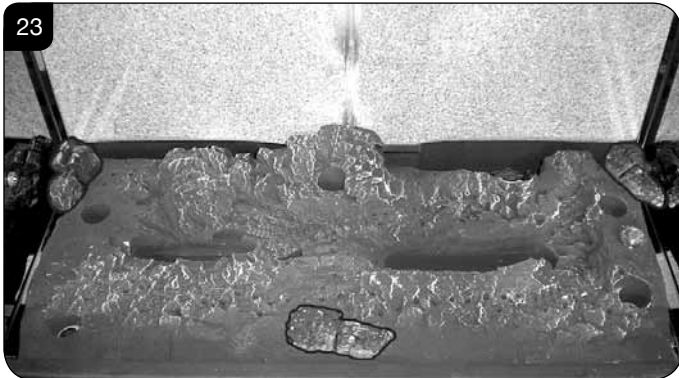

- 7.16 Place Log D on the left hand side of the burner. There is a hole on the underside of Log D which fits over the raised stud on the left of the burner. The back of the log should rest flat against the back panel, see Diagram 24.

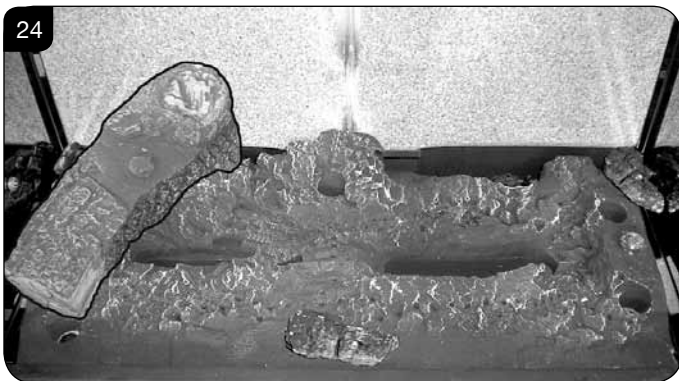

- 7.17 Place Log B on top of Log D. There is a hole on the underside of Log B which fits over the raised stud on Log D to secure in place. The right hand side of the log rests in the groove in the burner, see Diagram 25.

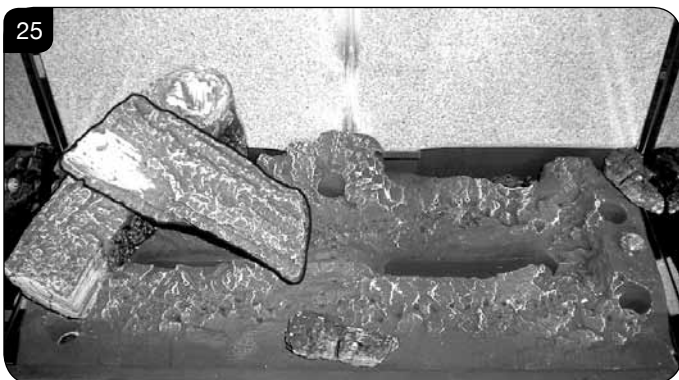

- 7.18 Place Log C on the right hand side of the burner. There is a hole on the underside of Log C which fits over the raised stud on the right of the burner. The back of the log should rest flush against the back panel, see Diagram 26.

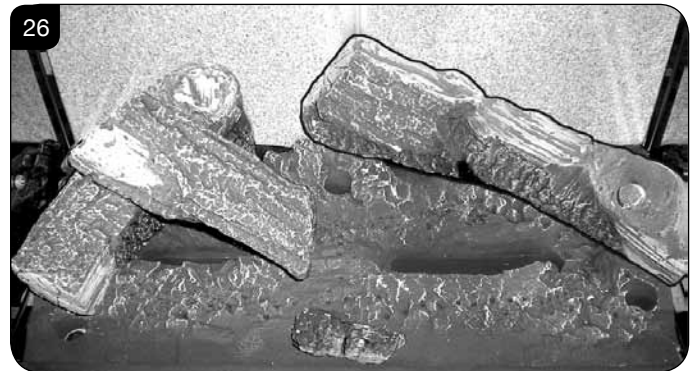

- 7.19 Place the log guard into position on the grooves on the sides of the firebox, see Diagram 27.



- 7.20 Place Log A across Log C. There is a hole on the underside of Log A which fits over the raised stud on Log C to secure in place. The small cut out on the left side of the log rests onto the log guard, see Diagram 28.



- 7.21 Once the logs are in place use some of the Embaglow wire wool provided and cover the ports in the burner tray with a liberal amount of fibres, in the highlighted areas shown in Diagram 29.  
NOTE: It is not necessary to use all of the Embaglow.

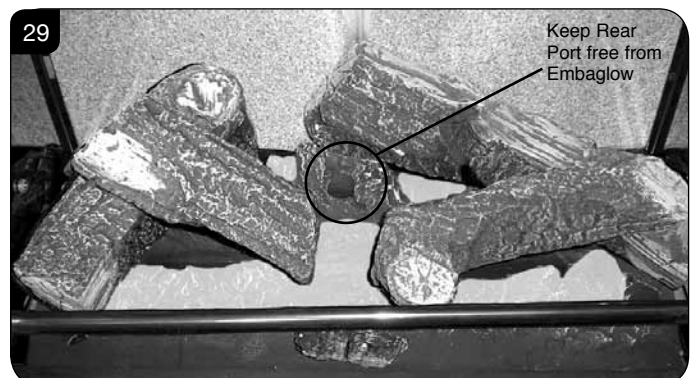



# Installation Instructions

## 8. Completion of Assembly

8.1 To fit the window frame:

### Small and Midi only:

Offer the frame to the foot of the opening and secure using 6 screws as shown, see Diagram 30, Arrow A.

### Medium only:

Offer the frame to the foot of the opening and secure using 8 screws as shown, see Diagram 30, Arrow A & B.

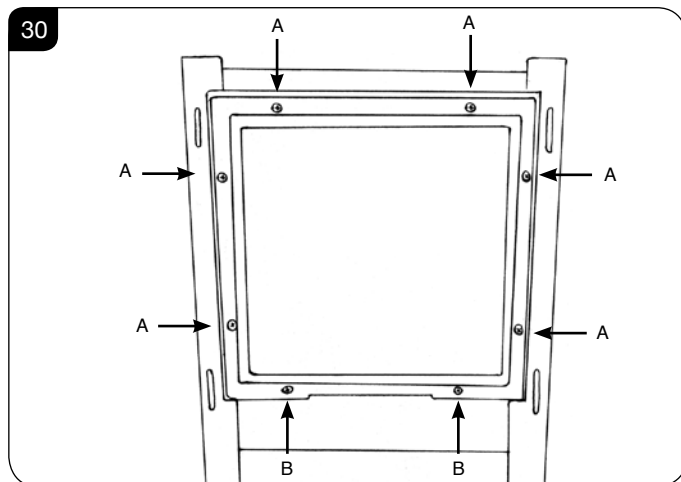

8.2 Replace ALL of the glass frame securing screws ensuring that a screw is present in all fixing slots.



**UNDER NO CIRCUMSTANCES SHOULD THE APPLIANCE BE USED IF ANY OF THE GLASS FRAME RETAINING SCREWS ARE LOOSE OR MISSING.**

8.3 Fit the front and the plinth by inserting the hooks on the back of the frame into the slots on the front of the appliance, see Diagram 31 & 32.

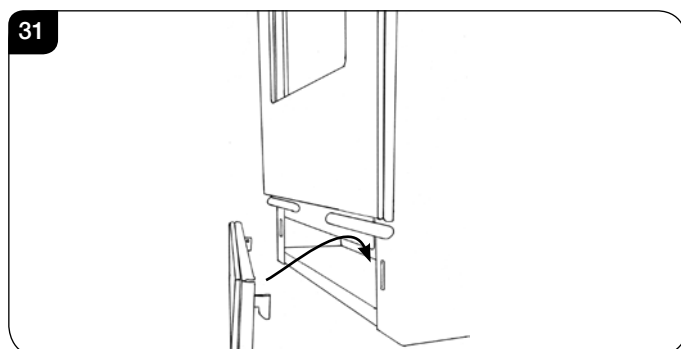

32

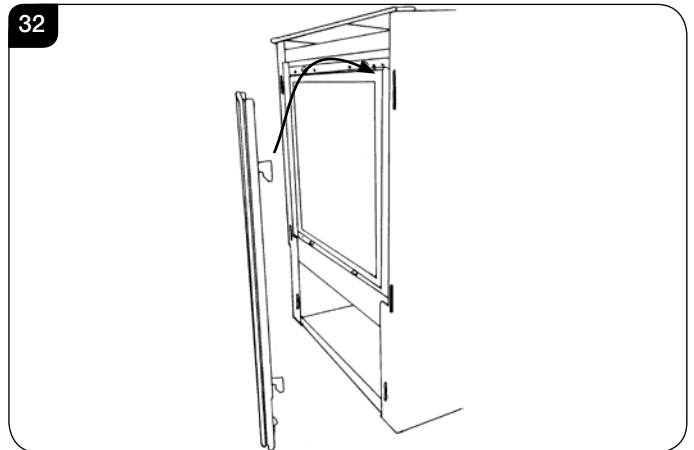

## 9. Operating the Appliance

9.1 The appliance has 4 flame settings:

1. High.
2. Medium.
3. Low.
4. Standby (Pilot only).

9.2 Both touch pad and handset allow you to manually switch between flame settings.

9.3 The Thermostatic handset also allows to set the appliance to automatically regulate the room temperature.

33

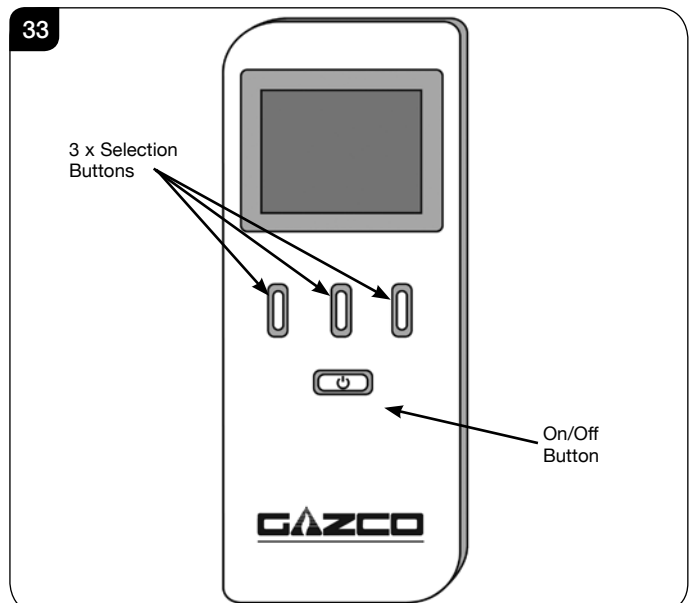

### Before using the remote control:

9.4 If there is no display on the LCD screen press any key.

9.5 When first powered, the handset displays the OFF screen. The handset may be locked as indicated by the padlock symbol (🔒), see Diagram 34.

# Installation Instructions

**NOTE:** To select a function from the options displayed at the bottom of the screen press the button directly below the desired function.

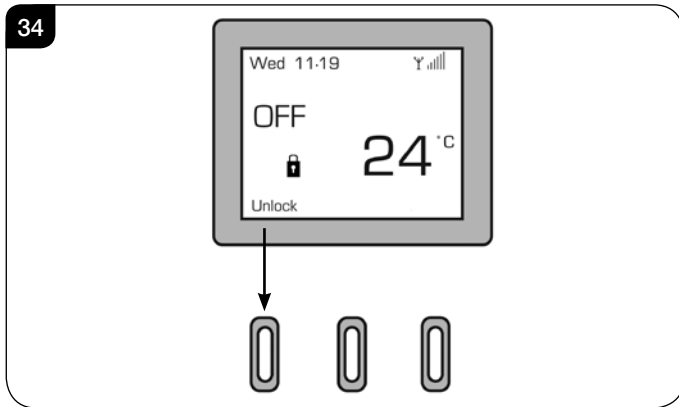

- 9.6 To unlock the handset select Unlock followed by OK - the symbol will change to an open padlock (🔓).
- 9.7 There are 3 different modes available for controlling and operating the appliance for full operating details see Section 2, User Instructions.

When a command from the handset is received a beep will sound and the LED on the handset will briefly illuminate.

**NOTE:** The LED flashes every 4 seconds to show that it is communicating with the appliance. After each command has been accepted the LED will cease flashing until the command has been carried out. Wait until the LED resumes flashing before giving another command.

## Manual Mode

### Switching the Appliance ON:

- 9.8 To light the appliance press the On/Off (⏻) button, this will bring up the LCD screen. Select the 'On' option on the left of the screen immediately followed directly by the OK button, a single beep will sound.

After the start up cycle has completed the appliance will light on the high flame setting (this can take up to 20 seconds).

Select the 'Manual' option on the screen to control the appliance.

### Decreasing the Flame Height:

- 9.9 From the high flame setting press DOWN (⏮) once to lower the flame to the medium setting.
- 9.10 From the medium flame setting press DOWN (⏮) once to lower the flame to the low setting.
- 9.11 From the low flame setting press DOWN (⏮) once to put the appliance in Standby mode (Pilot only).

### Increasing the Flame Height:

- 9.12 To light the appliance when it is in Standby mode press UP (⏭) once. The appliance will light on the **Low** flame setting.

- 9.13 From the low setting press UP (⏭) once to increase the flame setting to medium.
- 9.14 From the medium setting press UP (⏭) once to increase the flame setting to high.

**WARNING: IF THE APPLIANCE FAILS TO LIGHT OR BECOMES EXTINGUISHED IN USE, WAIT 3 MINUTES BEFORE ATTEMPTING TO RELIGHT.**

**IMPORTANT: YELLOW FLAMES TYPICALLY APPEAR WHEN THE APPLIANCE HAS REACHED NORMAL OPERATING TEMPERATURE. THIS CAN TAKE UP TO 30 MINUTES.**

### Switching the Appliance OFF:

- 9.15 To switch the appliance OFF press the On/Off (⏻) button once, see Diagram 1.

**FOR FULL OPERATING INSTRUCTIONS AND TROUBLESHOOTING SEE USER SECTION.**

## 10. Touch Pad Control

The touch pad control is located adjacent to the battery holder behind the lower front cover or frame, see Diagram 35.

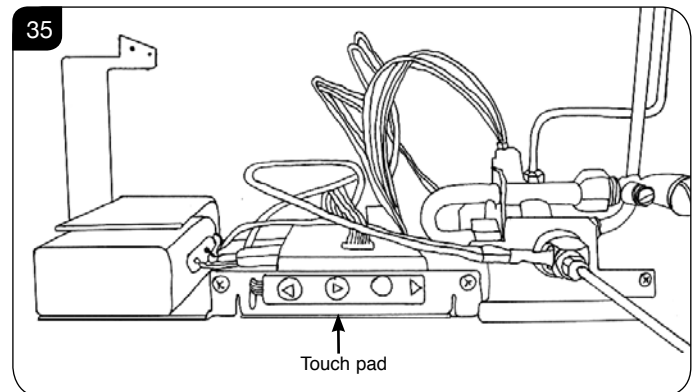

**When a command from the touch pad is received a beep will sound and the LED on the touch pad will briefly illuminate.**

**A second beep and flash of the LED will confirm the command has been carried out (this can take approximately 10 seconds). Wait for this confirmation before giving another command.**

### Lighting the appliance

- 10.1 Press the On/Off button once.
- If the pilot fails to light, press the ON/OFF button to switch OFF. Wait for at least 30 seconds before attempting to relight.
- 10.2 After the start up cycle has completed the appliance will light on the **high flame setting** (this can take up to 20 seconds).
- If the appliance is in Standby mode, pressing the UP (⏭) button will cause the main burner to ignite on the **Low** flame setting.

# Commissioning

- 10.3 To increase the flame height press the UP (▷) button.
- 10.4 To decrease the flame height press the DOWN (◁) button.
- 11.5 When on the lowest flame setting pressing the Down (◁) button will switch the appliance to Standby mode (pilot only).



**WARNING: IF THE APPLIANCE FAILS TO LIGHT OR BECOMES EXTINGUISHED IN USE, WAIT 3 MINUTES BEFORE ATTEMPTING TO RELIGHT.**



**IMPORTANT: YELLOW FLAMES TYPICALLY APPEAR WHEN THE APPLIANCE HAS REACHED NORMAL OPERATING TEMPERATURE. THIS CAN TAKE UP TO 30 MINUTES.**

### To Switch the Appliance OFF:

- 11.6 To turn the appliance **OFF** press the On/Off button once.

## Touch Pad Control Not Working

### If the appliance is not operating with the touch pad control:

- 11.7 Replace the batteries in the battery pack, see Section 6, User Instructions.
- 11.8 If the appliance still fails to operate consult your installer or Gazco retailer.

## 1. Commissioning

- 1.1 Close all doors and windows in the room.
- 1.2 Ignite the appliance and operate on maximum for 10 minutes.
- 1.3 Position a lighted smoke match just inside the draught diverter opening at the rear of the appliance.
- 1.4 Check all smoke is drawn into the opening, see Diagram 1.

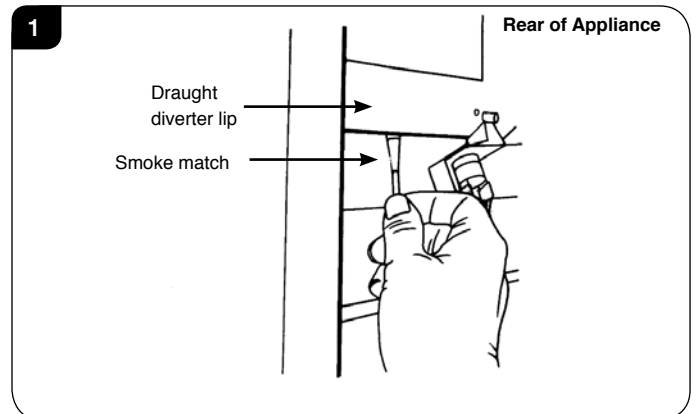

- 1.5 If there is any doubt, run the appliance for a further 10 minutes, and repeat the test.
- 1.6 If there are any extractor fans in adjacent rooms, the test must be repeated with the fans running on maximum and interconnecting doors open.

### IF SPILLAGE PERSISTS, DISCONNECT THE APPLIANCE AND SEEK EXPERT ADVICE.

- 1.7 Complete the Commissioning Checklist at the front of this manual covering:
  - Flue checks
  - Gas checks
  - Log layout - flame picture
- 1.8 Upon completion of the commissioning and testing of the installation and correct operation of the appliance, the installer must instruct the user how to operate the appliance.
- 1.9 Guide the user through the User Instructions paying particular attention to:
  - a) Regular servicing (Section 12 of the User Instructions).
  - b) Ventilation (Section 13 of the User Instructions) - point out the ventilation positions where applicable.
  - c) Hot surfaces (Section 15 of the User Instructions).
  - d) How the appliance works with the touch pad control (Section 5 of the User Instructions).
  - e) How the appliance works with the remote control handset and the modes of operation (Section 2 of the User Instructions).

# Commissioning

- f) How to change settings in the auto mode and program modes of operation.
- g) What to do if the appliance fails to operate (Section 16 of the User Instructions).

## 2. Pairing the appliance

If there is no communication between the remote control and the appliance after replacing the control box or the handset, it will be necessary to pair the two together.

**Before starting the pairing process ensure the handset is programmed to Channel 'C' see Section 3.**

- 2.1 Remove the 2 screws securing the control box.

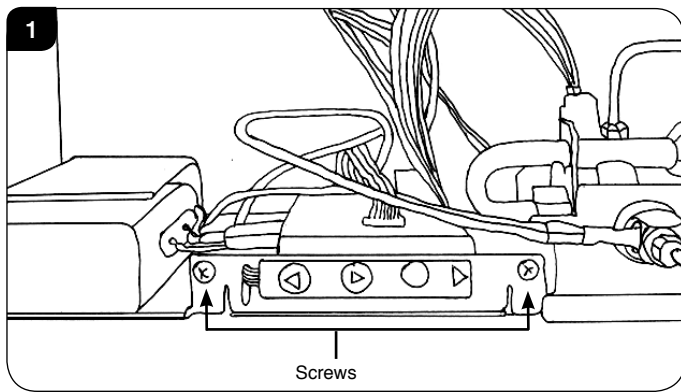

- 2.2 Ensure batteries are fitted and working in the handset.
- 2.3 Check all leads and cables are connected correctly.
- 2.4 Ensure the handset is unlocked. To unlock the handset select Unlock followed by OK - the symbol will change to (☐).
- 2.5 Press the ON/OFF button (⏻) on the handset and keep it depressed until the screen changes to the configuration menu. This may take up to 30 seconds and the screen may go blank before changing to the configuration screen.
- 2.6 When the configuration menu screen appears change the Pairing option to ON using the Change button.
- 2.7 Within 20 seconds press the yellow button on the control unit repeatedly until a single beep is heard confirming the pairing operation has been successful, see Diagram 2. This may be easier using a pencil, ball point pen or similar.

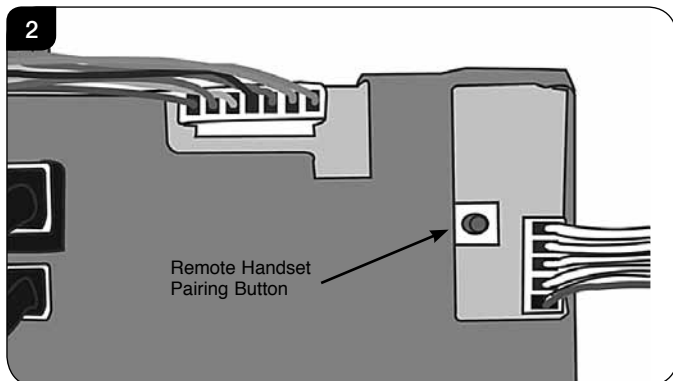

- 2.13 The remote handset will display a signal level in the top right hand corner. This may take up to 4 minutes.
- 2.14 Press the back button on the handset to return to the configuration menu and then again to return to the main menu.

## 3. Changing channel



**WHEN ATTEMPTING A NEW PAIRING PROCEDURE THE HANDSET SHOULD BE SET TO CHANNEL 'C'. IF THE APPLIANCE IS ALREADY SET TO CHANNEL 'C' BUT NO COMMUNICATION SIGNAL STRENGTH IS SHOWN ON THE HANDSET, IT WILL BE NECESSARY TO CHANGE THE COMMUNICATION CHANNEL USING THE FOLLOWING PROCEDURE.**

- 3.5 Ensure the handset is unlocked. To unlock the handset select Unlock followed by OK - the symbol will change to (☐).
- 3.6 Press the ON/OFF button (⏻) on the handset and keep it depressed until the screen changes to the configuration menu. This may take up to 30 seconds and the screen may go blank before changing to the configuration screen.
- 3.7 Press the button below the down arrow (↓) to scroll through the menu until 'Channel' is displayed.
- 3.8 The channel is normally pre-set to C. Press the button below 'Select' and then use the down arrow (↓) to set the handset to channel A or B.
- 3.9 Disconnect the batteries from the control box and reconnect after 10 seconds.
- 3.10 The remote handset will display a signal level in the top right hand corner. This may take up to 4 minutes, check the strength of the signal in the top right hand corner of the LCD display (☐).

# Servicing Instructions

## Servicing/Fault Finding Charts

### 1. Servicing Requirements

**IMPORTANT – The glass panel on this appliance should be checked for any signs of damage on the front face of the glass panel (scratches, scores, cracks or other surface defects). If damage is observed, the glass panel must be replaced and the appliance must not be used until a replacement is installed. Under no circumstances should the appliance be used if any damage is observed. Please isolate the appliance until a replacement glass panel has been obtained and installed. Replacement glass panels can be purchased from Gazco via the retailer from which the appliance was purchased or any other Gazco distributor.**

This appliance must be serviced at least once a year by a competent person.

All tests must be carried out in accordance with the current Gas Safe recommendations.

#### 1.1 Before Testing:

- Conduct a gas soundness test for the property ensuring there are no leaks before servicing.
- Check the operation of the appliance before testing.

#### 1.2 Special checks:

- Clean the burner using a vacuum cleaner with a soft brush attachment. Ensure all debris is removed from the burner ports.
- Clean away lint or fluff from the pilot.
- Clean away lint or fluff from under the burner.
- Check the spark gap on the pilot is correct.
- Ensure that the glass frame is secured correctly and that all retaining screws are in place.

1.3 Correct any faults found during the initial test.

1.4 Re-commission the appliance in accordance with Commissioning Procedures.

1.5 Advise the customer of any remedial work undertaken.

**REPLACE BATTERIES BEFORE ATTEMPTING TO RECTIFY ANY FAULTS.**

### IGNITION FUNCTIONAL CHECK 1

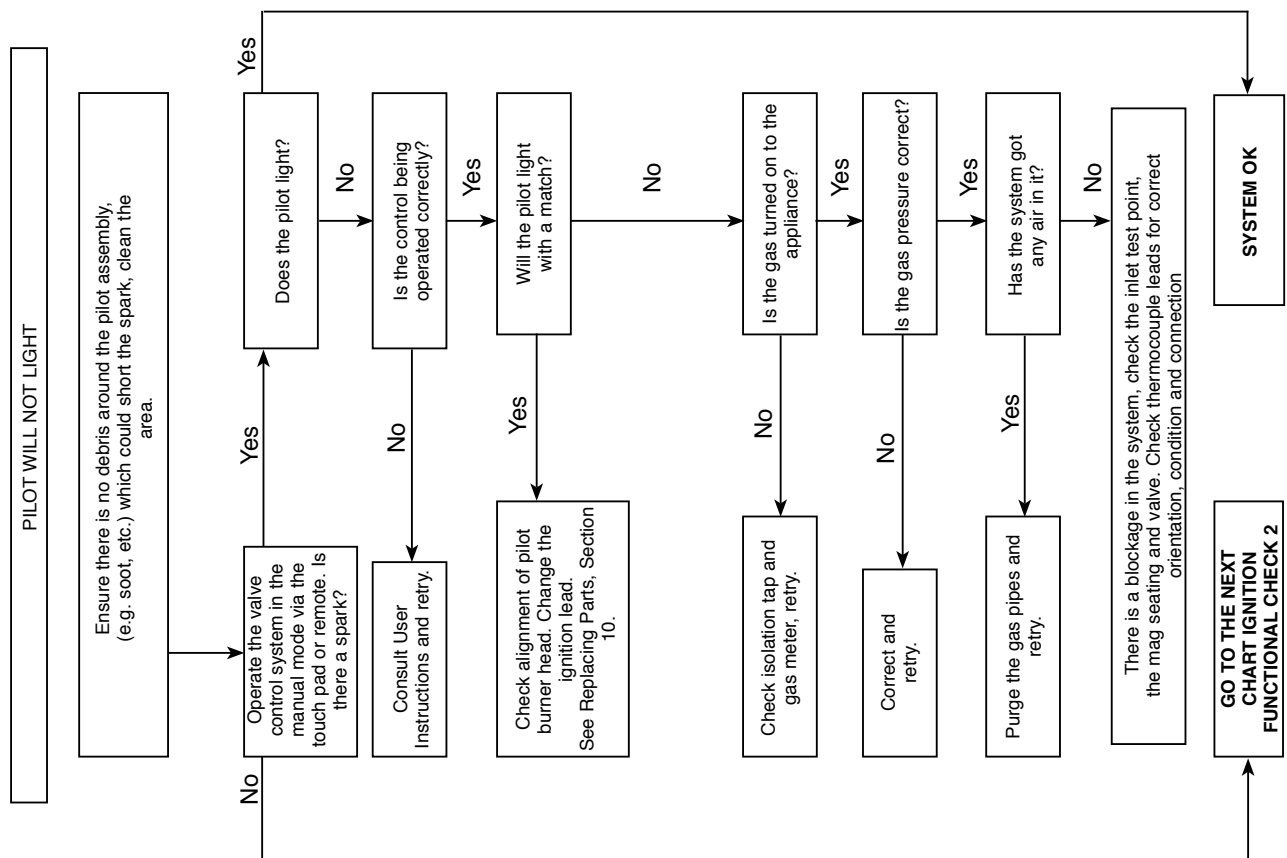

# Servicing Instructions

## Fault Finding Charts

### FLAME FAILURE FUNCTIONAL CHECK 3

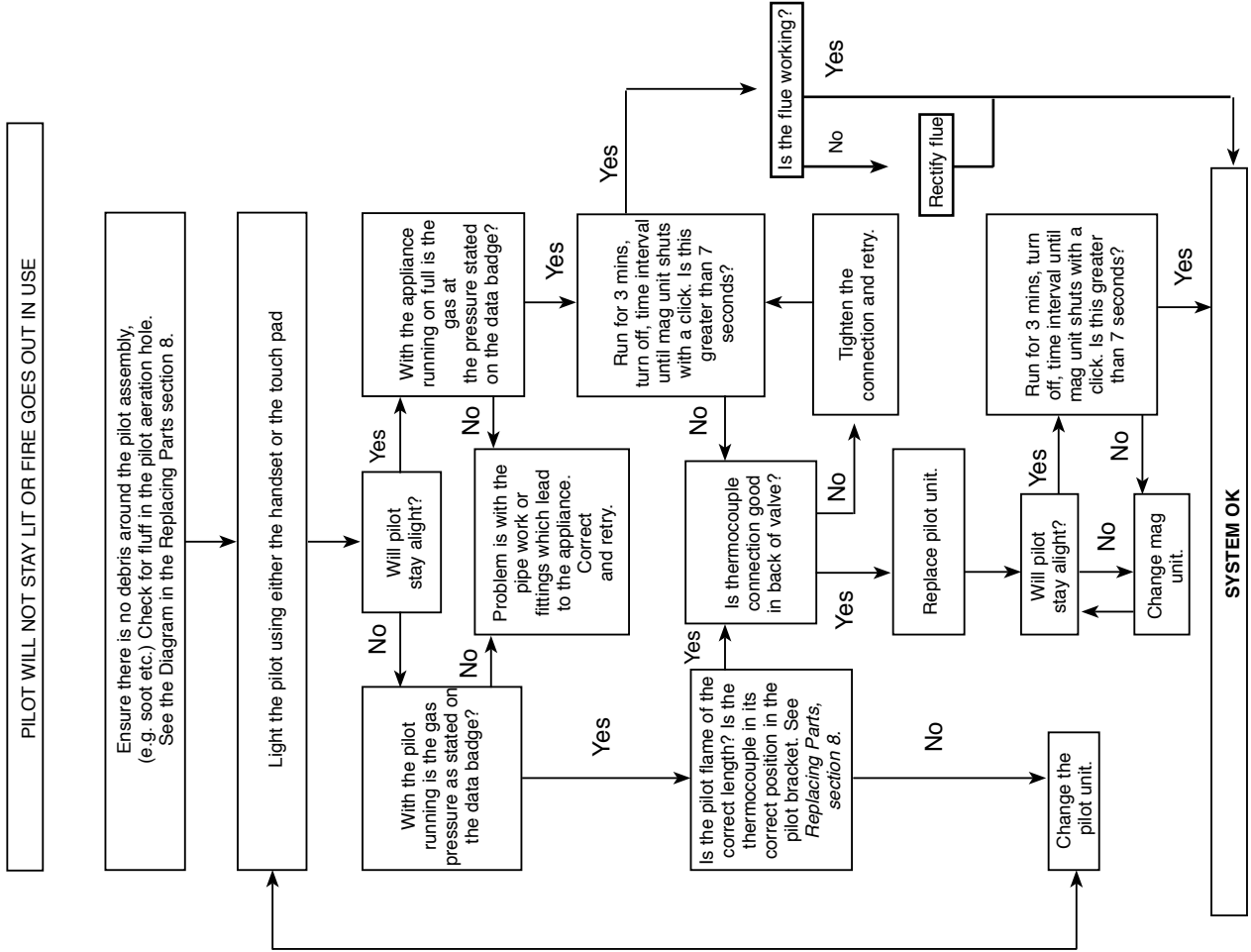

### IGNITION FUNCTIONAL CHECK 2

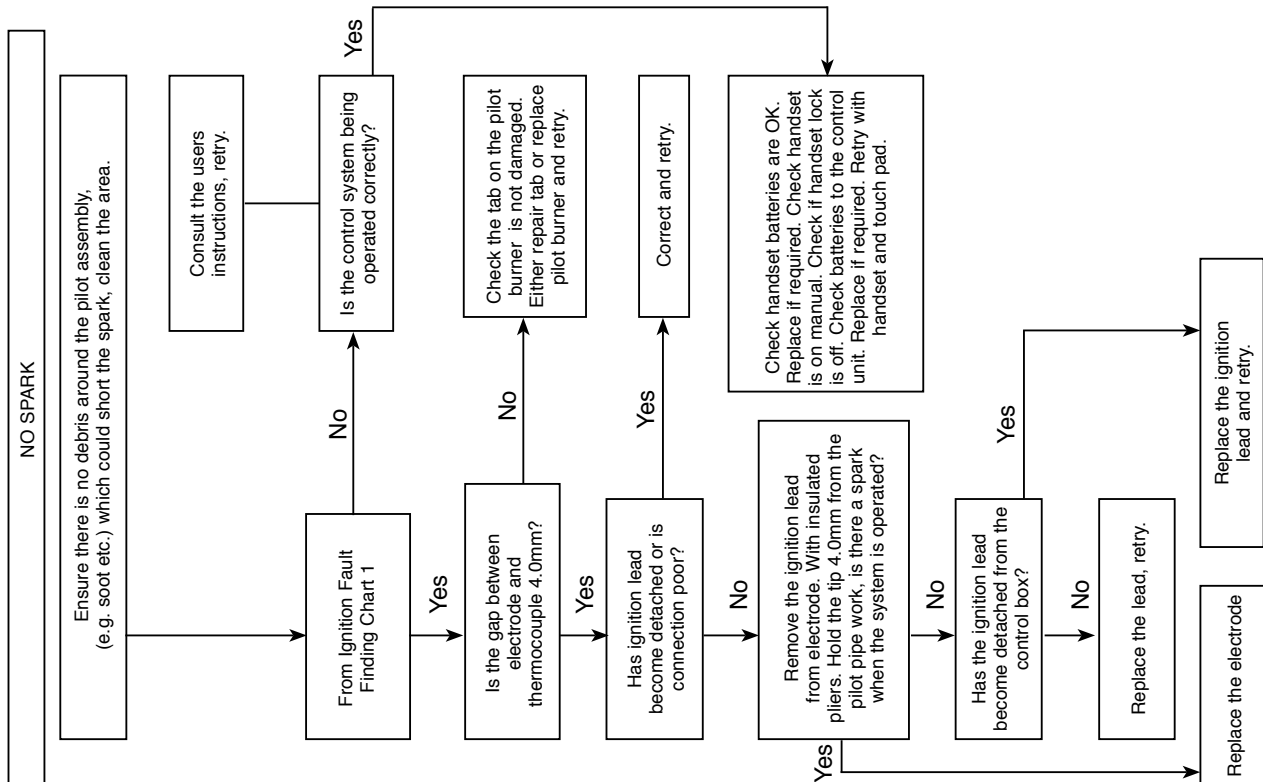

# Servicing Instructions

## Fault Finding Charts

### ELECTRONIC CONTROL VALVE FAULT ANALYSIS

Problem	Cause	Error Message	LCD Display	Solution	
Does not ignite	No batteries or flat batteries in battery box	10 beeps	BATTERY ERROR	Place new batteries in battery box	
	ROM error	2 cycles of 3 beeps	ROM ERROR	Change control unit	
	Support test error	2 cycles of 5 beeps	SUPPORT ERROR	Connect earth cable from control box to valve	
	Bad reception of remote handset signal				Change batteries in the remote handset
					Check the reception of signal from a shorter distance
					Try pairing again
	No response to touch control buttons	If LED is continuously on, the cable is connected the wrong way round		Ensure the touch control cable is correctly connected (see installation manual)	
	Cable loose or broken or connected wrong way round			Change touch control	
Supply cable to valve disconnected or broken	2 cycles of 5 beeps	SUPPORT ERROR	Reconnect or replace valve cable		
Ignition cable disconnected or broken			Connect ignition cable		
Sparks but no pilot ignition	Gas valve supply off or no gas			Check gas installation. Open gas valve	
	Valve cable disconnected or broken			Connect valve cable correctly	
	Interrupter cable disconnected or broken			Connect correctly or replace pilot cable	
Pilot ignites but does not stay on	Pilot is not warmed up			Check pilot flame and verify that it heats the pilot	
	Interrupter cable badly connected			Change polarity of pilot cable	
	Interrupter cable disconnected or broken			Connect pilot cable	
Ignites from remote handset but not from touch pad	Touch control cable disconnected or broken			Connect or replace touch control cable	
	Defective touch control buttons			Change touch control	
Ignites from touch pad but not from remote	Bad communication with handset			Check batteries in handset	
				Check reception of signal from a shorter distance	
				Try pairing again	
				Try changing the channel in the configuration menu	
Switches off after 6 seconds	Short circuit in touch control	5 beeps	BUTTON ERROR	Change touch control wiring	
Low batteries on remote			Low battery	Change the batteries in the remote	
Appliance switches off		2 cycles of 3 beeps	CONFIG ERROR	Change control unit	
		2 cycles of 3 beeps	EEPROM ERROR	Try pairing again	
				Change control unit	
	Loss of communication between appliance and remote for 18min	20 beeps		The remote is too far from the appliance	
				Replace batteries in handset	
	High temperature on control unit	1 long beep	TEMP ERROR	If this occurs more than once call the technical service	
	Ambient temperature higher than configured		Over Temperature	Check the correct configuration of safety temperature	

# Servicing Instructions - Replacing Parts

## 1. General

- 1.1 All main components can be replaced without removing the appliance from its installation.  
**IT IS ESSENTIAL THAT THE GAS SUPPLY TO THE APPLIANCE IS TURNED OFF AT THE ISOLATION DEVICE BEFORE PROCEEDING FURTHER.**
- 1.2 **DISCONNECT BATTERIES BEFORE SERVICING THE APPLIANCE**
- 1.3 **Removal of Flue**  
If, for any reason, the flue has to be removed from the appliance, the seal must be replaced in the inner spigot.
- 1.4 Access to the controls is restricted and the whole of the control assembly is to be removed as one unit, Servicing Section 6.

## 2. Decorative Front



**IMPORTANT: THE OUTER PANELLING OF THE RIVA VISION IS MADE FROM GLASS. USE CAUTION WHEN INSTALLING, REMOVING AND STORING AS THE COMPONENTS ARE FRAGILE AND COULD BREAK UNLESS HANDLED CAREFULLY.**

### 2.1 All Models

Remove the plinth to access the touchpad and battery box by lifting the hooks clear of the slots on the front of the appliance, see Diagram 1.

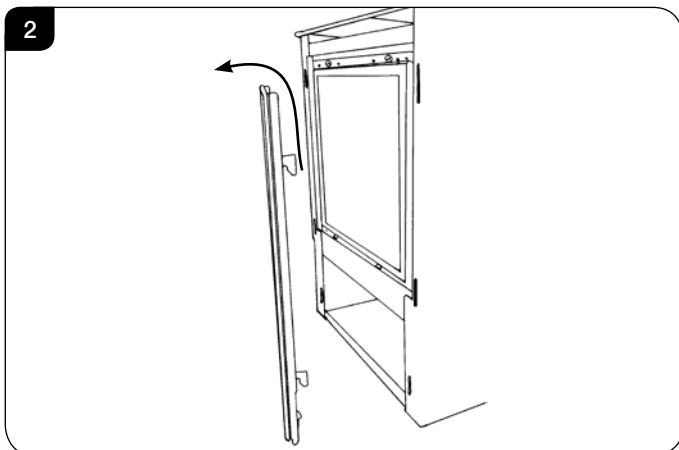
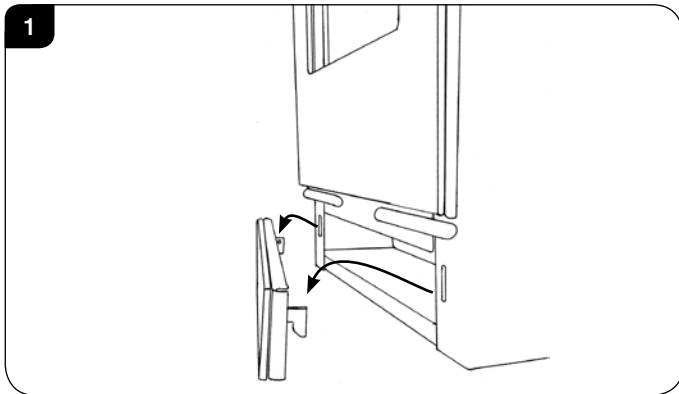

- 2.2 Remove the frame to gain complete access to the control box and the viewing aperture by lifting the hooks clear of the slots on the front of the appliance, see Diagram 2.
- 2.3 The glass frame must be refitted to the appliance following cleaning or servicing. Hold in position and secure with the screws
- 2.4 Replace ALL of the securing screws ensuring that a screw is present in all fixing slots.



**UNDER NO CIRCUMSTANCES SHOULD THE APPLIANCE BE USED IF ANY OF THE GLASS FRAME RETAINING SCREWS ARE LOOSE OR MISSING.**

## 3. Window Frame Assembly

### Small and Midi only:

- 3.1 Using screwdriver remove the 6 screws securing the window panel to the appliance, see Diagram 3, Arrows A. Take care to support the glass when removing the screws.

### Medium only:

- 3.2 Using screwdriver remove the 8 screws, securing the window panel to the appliance, see Diagram 3, Arrows A & B. Take care to support the glass when removing the screws.

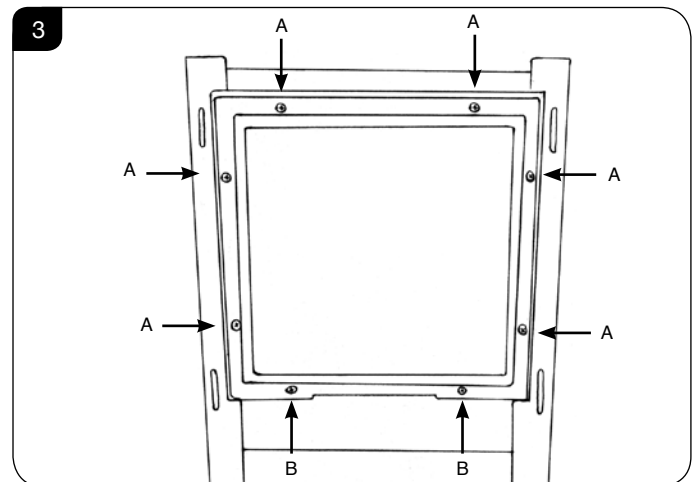

- 3.3 Place carefully to one side.
- 3.4 The glass frame must be refitted to the appliance following cleaning or servicing. Hold in position and secure with the screws
- 3.5 Replace ALL of the securing screws ensuring that a screw is present in all fixing slots.



**UNDER NO CIRCUMSTANCES SHOULD THE APPLIANCE BE USED IF ANY OF THE GLASS FRAME RETAINING SCREWS ARE LOOSE OR MISSING.**



# Servicing Instructions - Replacing Parts

## 4. Baffle & Ceramic Liners (Small & Midi only)

- 4.1 To access the burner tray and interior workings of the appliance it may be necessary to remove the baffle and the liners.

### BAFFLE

- 4.2 The baffle must be removed before the liners can be taken out of the appliance.

To do this undo the 2 screws securing it to the roof of the firebox, see Diagram 4.

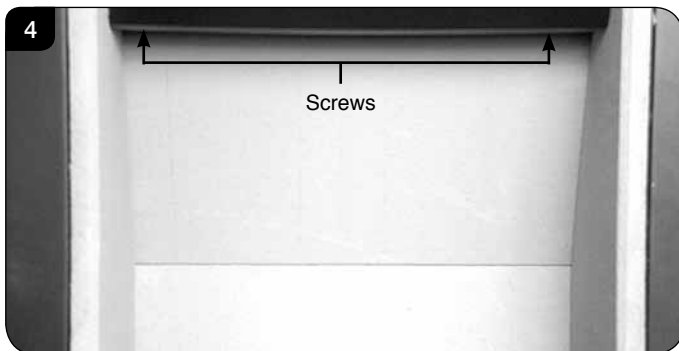

- 4.3 The baffle can now be removed through the front of the appliance.

### CERAMIC LINERS

Once the baffle has been placed carefully to one side the liners can then be taken out in the following order.

- 4.4 To remove the Left Hand liner first tilt inwards towards the centre of the firebox before lifting up and pulling out through the front of the firebox, see Diagram 5.

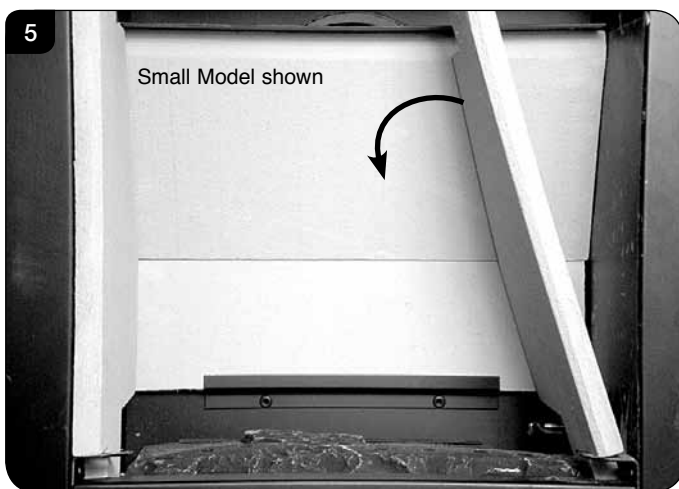

- 4.5 To remove the Right Hand liner first tilt inwards towards the centre of the firebox before lifting up and pulling out through the front of the firebox, see Diagram 5.

The two side liners also support the raised rear liner. Taking out the side liners will allow the rear liner to drop down so ensure it is supported and removed carefully, see Diagram 6.

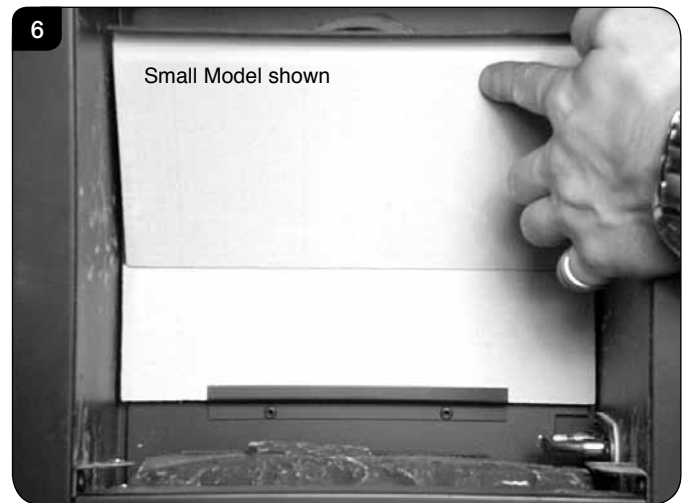

- 4.6 The lower rear liner does not need to be removed from the bracket in order to access the burner tray for maintenance, but can be lifted off in order to clean or replace, see Diagram 7.

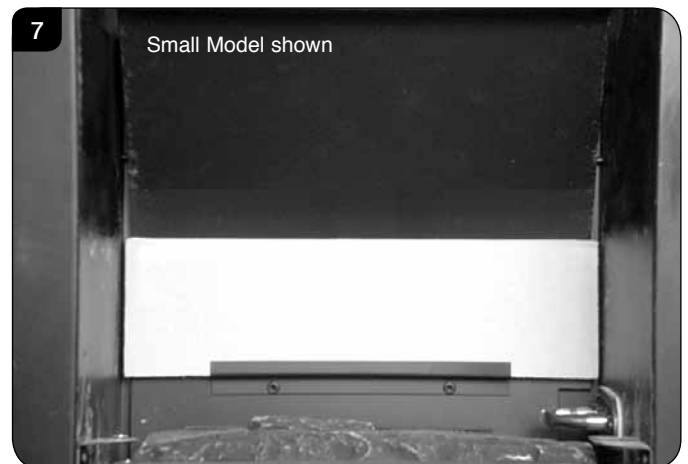

- 4.7 With the liners and baffle removed the firebox is clear for cleaning and maintenance, see Diagram 8.

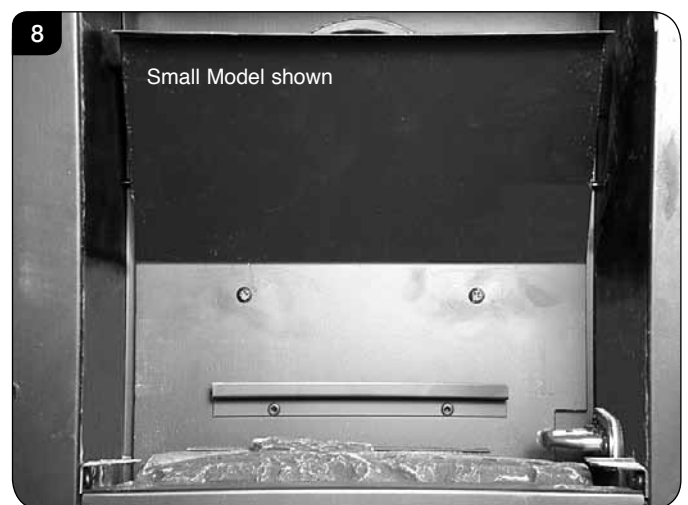

- 4.8 To replace the liners and baffle reverse these procedures.

# Servicing Instructions - Replacing Parts

## 5. Baffle & Liners (Medium only)

- 5.1 To access the burner tray and interior workings of the appliance it may be necessary to remove the baffles and the liners.
- 5.2 This appliance has 2 baffles, 1 metal and 1 vermiculite, that must be removed before the liners can be taken out of the appliance.
- 5.3 Remove the logs.

### METAL BAFFLE

To remove the metal baffle:

- 5.4 Undo the 3 screws securing it to the roof of the firebox, see Diagram 9.

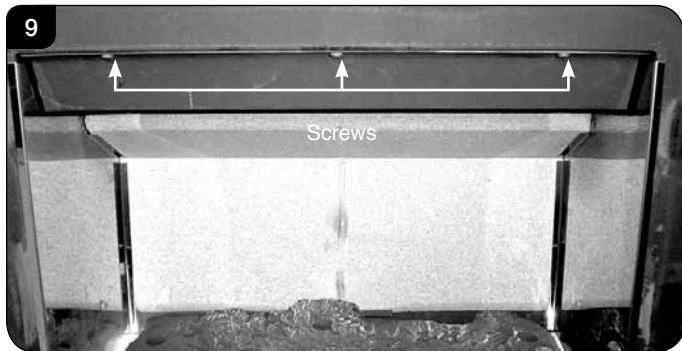

- 5.5 The baffle can now be removed through the front of the appliance.

### VERMICULITE BAFFLE

To remove the vermiculite baffle:

- 5.6 Lift the vermiculite baffle and slide out through the front of the appliance, see Diagram 10.

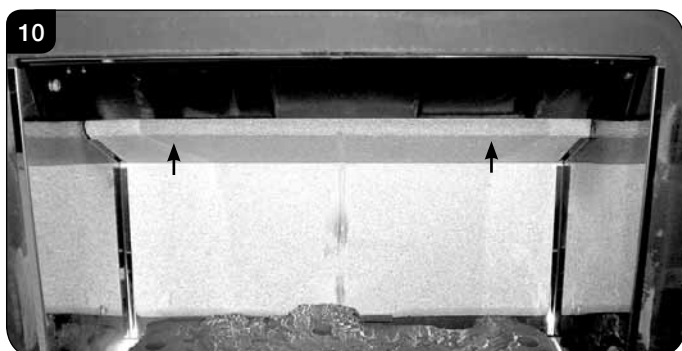

Once the baffles have been placed carefully to one side the liners can then be taken out in the following order.

### REFLECTIVE LINERS

- 5.7 To remove the left hand liner undo the 3 screws, including the 1 under the log guard bracket, see Diagram 11.

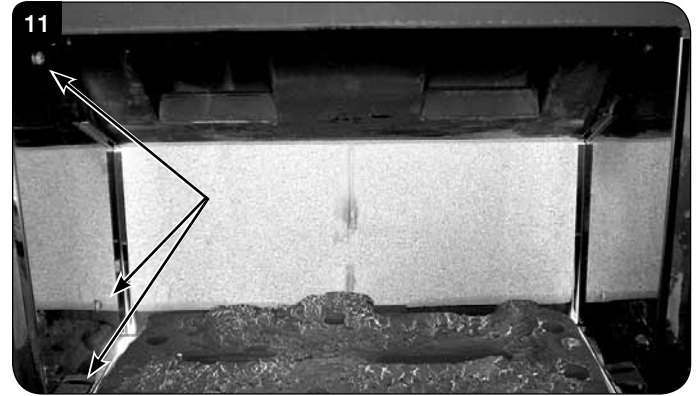

- 5.8 Remove the log guard bracket.
- 5.9 Tilt the liner inwards towards the centre of the firebox before lifting up and pulling out through the front of the firebox, see Diagram 12.

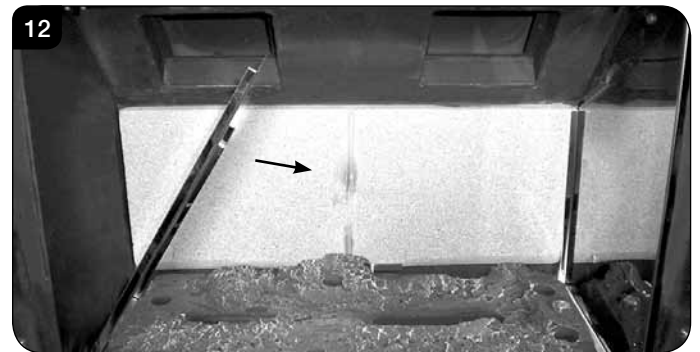

- 5.10 To remove the right hand liner undo the 3 screws, including the 1 under the log guard bracket, see Diagram 11.
- 5.11 Remove the log guard bracket.
- 5.12 Tilt the liner inwards towards the centre of the firebox before lifting up and pulling out through the front of the firebox, see Diagram 12.

### VERMICULITE LINER

- 5.13 The rear liner does not need to be removed in order to access the burner tray for maintenance, however it is advisable to remove the rear panel to avoid possible damage and to clean or replace.

# Servicing Instructions - Replacing Parts

- 5.14 To remove the back panel lift out of the bracket and remove through the front of the appliance, see Diagram 13.

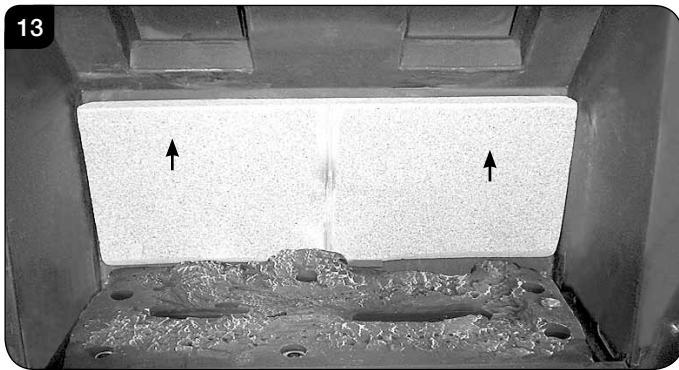

- 5.15 With the liners and baffle removed the firebox is clear for cleaning and maintenance, see Diagram 14.

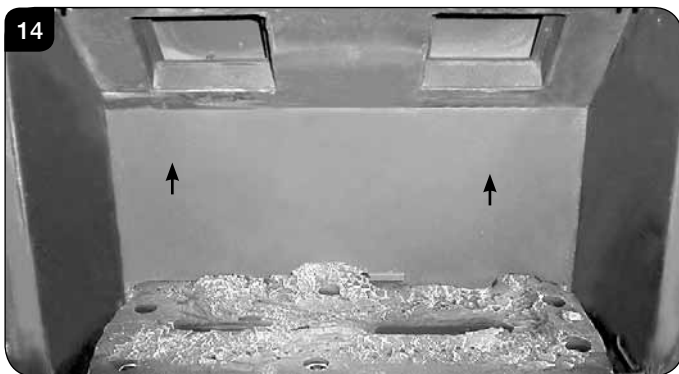

## 6. Main Burner

### Small & Midi

To replace the main burner:

- 6.1 Remove the baffle and enamel liners, see Section 4.
- 6.2 Remove the burner bracket screw on the left hand side of the firebox, Diagram 15.
- 6.3 Remove the 3 securing screws from the edges of the burner, see Diagram 15.

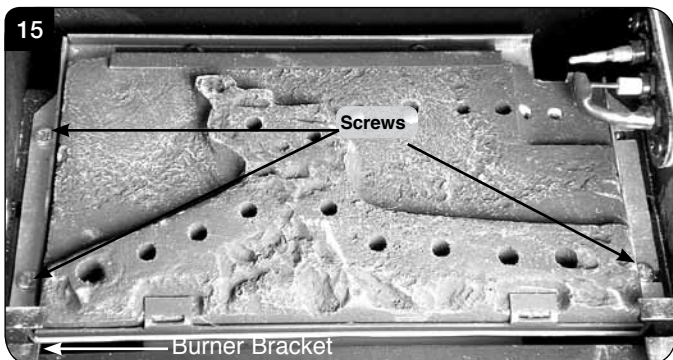

- 6.4 Slide the burner fully to the right whilst lifting the Left Hand side clear of the bracket, see Diagram 16.



- 6.5 Slide the burner back to the left and out of its location.  
**IMPORTANT: Take care when removing the burner not to damage the ceramic pad with the pilot unit attached.**

Refit in reverse order

## Medium

To replace the main burner:

- 6.6 Remove the baffles and liners, see Section 5.
- 6.7 Lift the left side of the burner up first and remove through the front of the fire box.

## 7. Control Assembly

**DISCONNECT THE BATTERIES PRIOR TO REMOVAL OF THE ASSEMBLY PARTS. SEE SECTION 8 USER INSTRUCTIONS.**

- 7.1 It is not necessary to remove the complete control assembly to service or replace parts of this appliance. The following sections will detail how to individually remove and replace each element.

## 8. Pilot Unit

### 8a. Small & Midi

The pilot assembly consists of five components, which can be individually changed, these are:

- Pilot burner bracket.
- Pilot Injector
- Electode
- Thermocouple.
- Gasket.

- 8.1 Turn the gas supply off at the isolation device, remove the door and place to one side, carefully remove the ceramic fuel bed components.

# Servicing Instructions - Replacing Parts

## Pilot Burner Bracket

- 8.2 Remove the two fixing screws from the pilot bracket, see Diagram 17. Gently draw the assemble away from the firebox to give access to the nuts and ignition lead.

**NOTE: TAKE CARE NOT TO DAMAGE THE GASKET.**

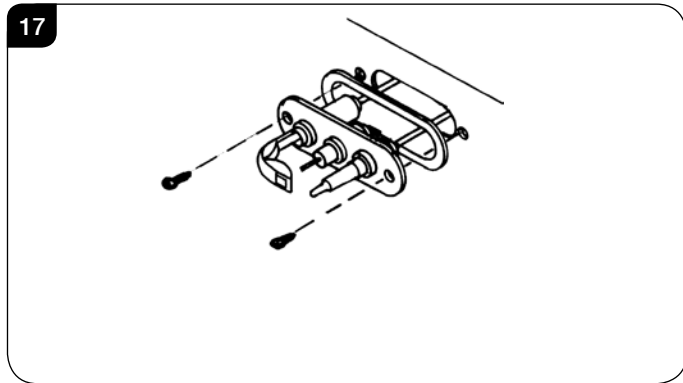

## Pilot Injector

- 8.3 Undo the compression nut on the pilot feed pipe and withdraw the injector which will be hooked onto the olive. When replacing an injector always make sure it is hooked onto the olive before inserting it into the pilot burner, see Diagram 18.

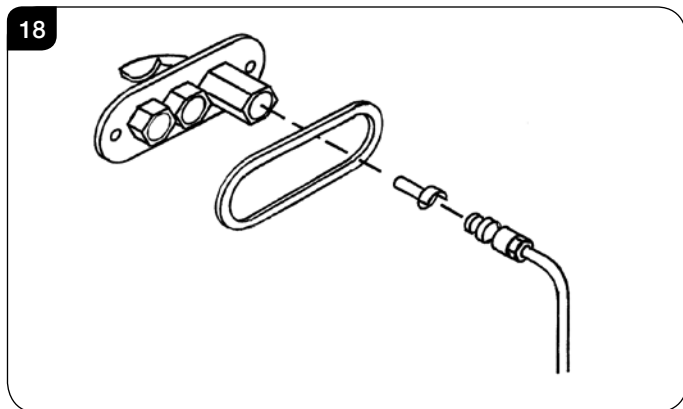

## Electrode

- 8.4 Disconnect the ignition lead and undo the retaining nut. The electrode can now be removed, note the orientation of the electrode terminal when reassembling, see Diagram 19.

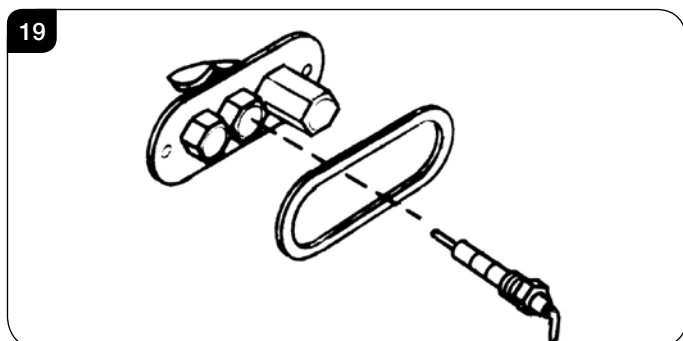

## Thermocouple

- 8.5 Undo the retaining nut and withdraw the thermocouple. Undo the thermocouple from the back of the gas valve, see Diagram 20. Reassemble in reverse order. Do not overtighten.

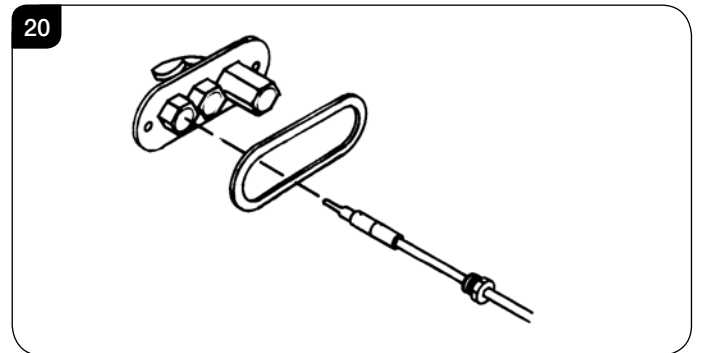

## Gasket

- 8.6 Disconnect all the above components and withdraw the gasket. If it is damaged, replace with a new item. Always replace the gasket first when reassembling the pilot components.

## 8b. Medium

The pilot assembly consists of four components which can be individually changed:

Pilot burner bracket  
Electrode  
Pilot injector  
Thermocouple

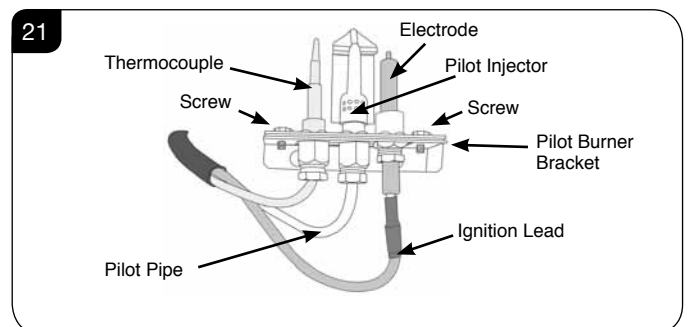

- 8.7 Turn the gas supply off at the isolation device, remove the door and place to one side, carefully remove the ceramic fuel bed components.

# Servicing Instructions - Replacing Parts

## Pilot Burner Bracket

To remove the Pilot Burner Bracket:

- 8.8 **First remove the electrode, pilot pipe and thermocouple as described in the following sections.**
- 8.9 Remove the 2 screws securing the bracket. The pilot burner bracket can now be removed.
- 8.10 Replace in reverse order.

## Electrode

- 8.11 Pull the ignition lead off the electrode and undo the retaining nut, see Diagram 21.
- 8.12 Replace with a new electrode. Do not over-tighten the nut; this could break the component.
- 8.13 Replace the ignition lead by pushing the spade connector onto the terminal (electrode).

## Pilot Injector

- 8.14 Undo the pilot pipe from the gas valve and from the underside of the pilot burner, see Diagram 21.
- 8.15 Remove the pipe and the injector drops out from the burner.

## Thermocouple

- 8.16 Disconnect the thermocouple from the gas valve/interrupter.
- 8.17 Note the position of the interrupter leads. The lead with the red tag **MUST** be placed closest to the gas valve.
- 8.18 Undo the thermocouple nut in the back of the pilot bracket half a turn. This releases the thermocouple.
- 8.19 When replacing with a new thermocouple, take care to bend the new component to the same shape as the thermocouple just removed.
- 8.20 To refit the thermocouple into the pilot bracket, ensure it is pushed fully into the hole. There is a stop on the thermocouple to set the height.
- 8.21 Lock the retaining nut just enough to grip the thermocouple.
- 8.22 Connect the thermocouple to the valve/interrupter **taking care not to over-tighten.**

## 9. Ignition Lead

### 9a. Small & Midi

- 9.1 Gain access to the back of the pilot assembly, see Section 8 and disconnect the ignition lead from the electrode.
- 9.2 Cut the cable tie securing the vida flex (if present) and pull the lead through the vida flex.
- 9.3 If necessary cut any cable ties and disconnect the lead from the control box, see Diagram 22.

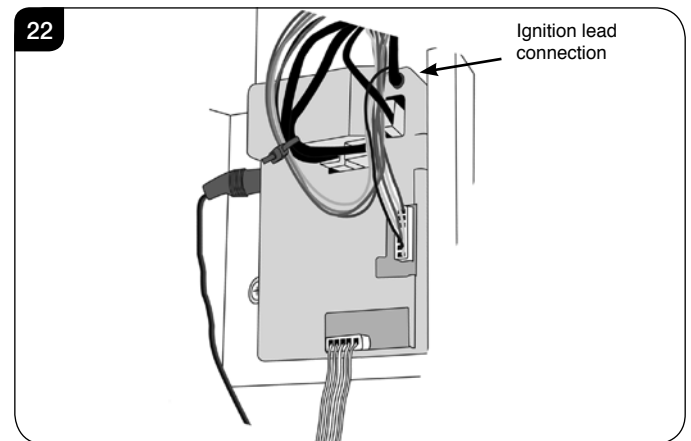

- 9.4 Replace in reverse order.
- 9.5 Ensure the lead is passed through the vida flex, secured with a cable tie and the red insulated end is attached to the electrode.

**Note the direction of the lead. The new lead must follow exactly the same route.**

### 9b. Medium

To replace the ignition lead:

- 9.6 Access the Main Control Assembly by removing the 2 screws on either side of the touch pad and pulling forward, see Diagram 23.

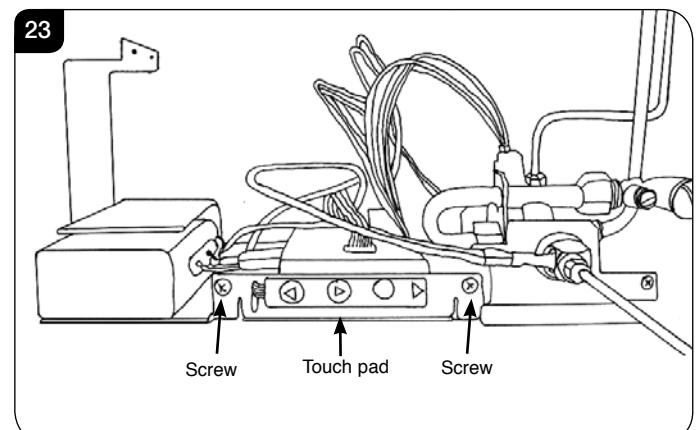

# Servicing Instructions - Replacing Parts

- 9.7 Remove the ignition lead from the control box, see Diagram 24.

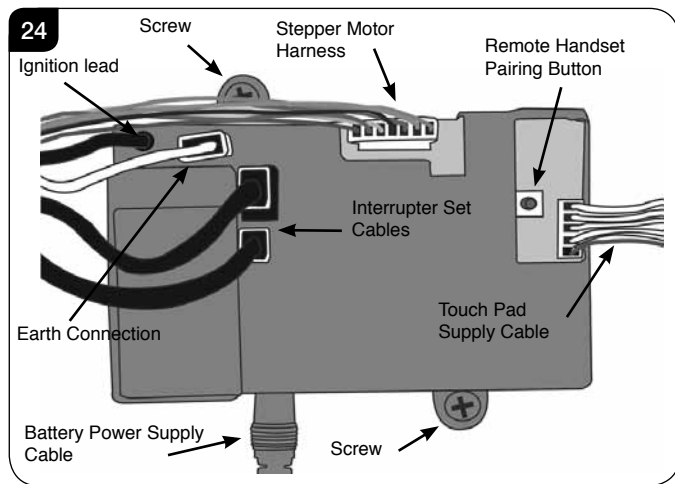

- 9.8 Remove the ignition lead from the electrode, see Diagram 21.

**Note the direction of the lead. The new lead must follow exactly the same route.**

**NOTE: THE IGNITION LEAD MUST NOT PASS IN FRONT OF THE CONTROL BOX AS THIS CAN DAMAGE THE SENSITIVE ELECTRONICS.**

## 10. Gas Valve

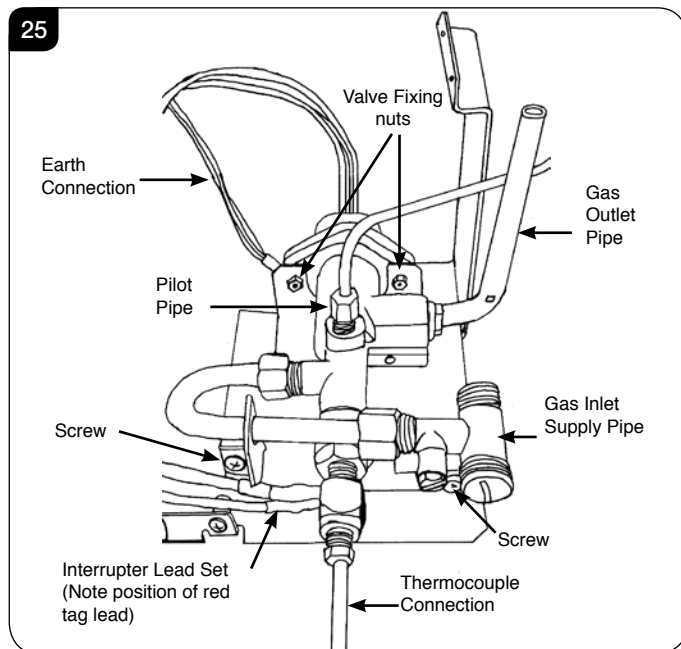

To change the gas valve:

- 10.1 Disconnect the pilot pipe.  
 10.2 Disconnect the thermocouple, interrupter leads and the interrupter block.  
 10.3 Remove the 2 screws securing the valve bracket, see Diagram 25.

- 10.4 Disconnect the gas injector pipe.

**Note - make a note of the location in the interrupter block of the lead with the red tag marking.**

- 10.5 Carefully pull the valve and bracket forward making sure there is no damage to the wires.  
 Note: To ease this process the control box can be pulled to one side for access.  
 10.6 Disconnect the stepper motor harness from the control box, see Diagram 24.  
 10.7 Undo the inlet pipe nut.  
 10.8 Remove the 2 fixing nuts and earth lead.  
 10.9 Replace the valve and refit into the appliance following this section in reverse order ensuring:  
 10.10 The earth cable ring tag is positioned between the valve body and the bracket.  
 10.11 The interrupter leads are connected correctly with the red tag lead nearest to the gas valve body.  
 10.12 The touchpad lead locates in the tab on the control box. Ensure it is not trapped behind the fixings.

## 11. Magnetic Safety Valve

To replace the magnetic safety valve:

- 11.1 Undo the thermocouple from the interrupter block and remove the two interrupter leads.  
 11.2 Unscrew the interrupter block from the back of the valve.  
 11.3 Undo the silver magnetic valve retaining nut on the back of the valve.  
 11.4 Gently tap out the mag valve.  
 11.5 Replace with a new unit.  
 11.6 Reassemble in reverse order ensuring that the interrupter leads are connected correctly with the red tag lead nearest to the gas valve body.  
 11.7 Check for leaks.

# Servicing Instructions - Replacing Parts

## 12. Control Box

- 12.1 Undo the 2 screws securing the control box to the control assembly bracket.
- 12.2 Disconnect from the control box:
  - Ignition lead
  - Thermo current cables
  - Earth connection
  - 7-way stepper motor plug
  - The battery power supply cable
  - The touch pad control cable

See Diagram 26 for details.

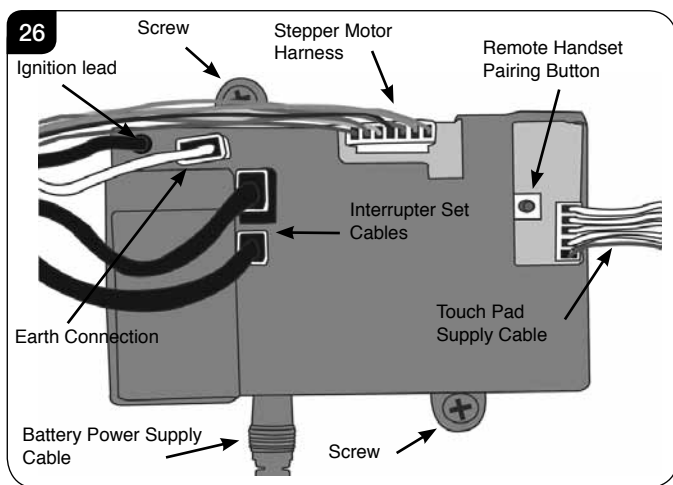

- 12.3 Undo the 2 x screws holding the control box, see Diagram 26. The control box can now be replaced.
- 12.4 After replacing the control box ensure all cables and connections are refitted, see Diagram 27.

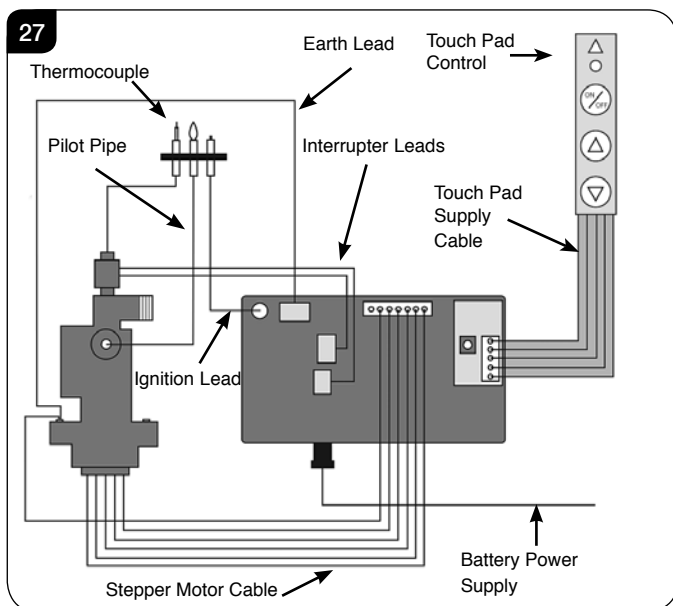

- 12.5 Prior to re-connection of the control box to the appliance, if there is no communication between the remote handset and the appliance, or if the handset is replaced, it will be necessary to pair the handset with the appliance. Please refer to Commissioning Section 2.
- 12.6 Ensure batteries are fitted and working in the handset.
- 12.7 Re-fit the touch pad control cable and the battery power supply cable to the control box.

## 13. Main Injector

- 13.1 Turn the gas supply off at the isolation device. Refer to Section 6, Replacing Parts to remove the main burner.
- 13.2 Undo the compression nut from the feed pipe at the gas control under the appliance.
- 13.3 Working from inside the firebox, remove the lock nut from the injector, see Diagram 20 and withdraw the injector complete with the feed pipe from under the appliance.

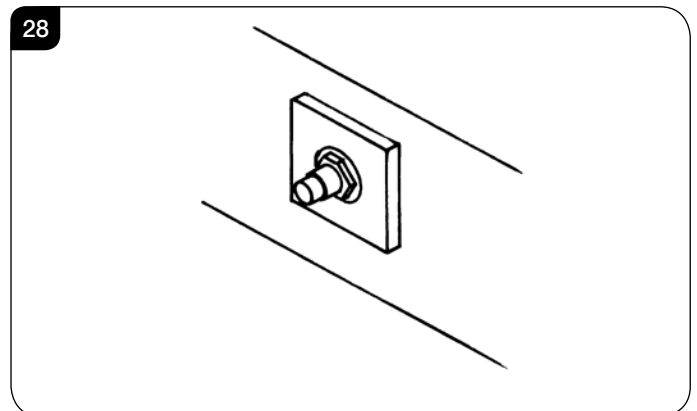

- 13.4 Holding the injector with a spanner, undo the feed pipe.  
**NOTE: THE ORIENTATION OF THE INJECTOR.**
- 13.5 Reassemble in reverse order, turn on the gas supply and check for any leaks.

# Servicing Instructions - Replacing Parts

## 14. Primary Aeration Plate

**NOT ALL MODELS HAVE AERATION PLATES. REFER TO TECHNICAL SPECIFICATIONS, PAGE 16.**

- 14.1 Remove the burner module as described in Servicing section 6.

### Small & Midi

- 14.2 Remove the fixing screw and slide the plate off the venturi.
- 14.3 Replace with the correct size plate and secure with the screw. Ensure the lower edge of the plate is located over the venturi flange, see Diagram 29.

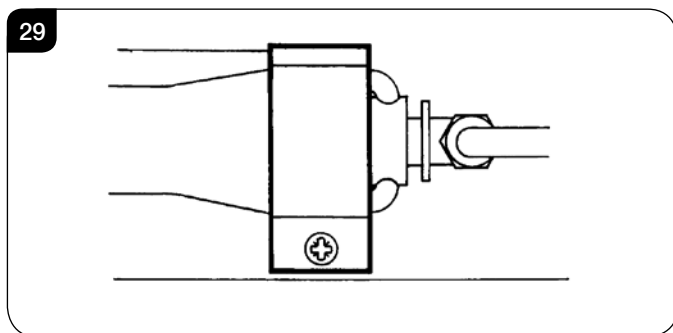

### Medium

- 14.4 Remove the fixing nuts and slide the plate off the venturi.
- 14.5 Replace with the correct size plate and secure with the nuts. Ensure the lower edge of the plate is located over the venturi flange, see Diagram 30.

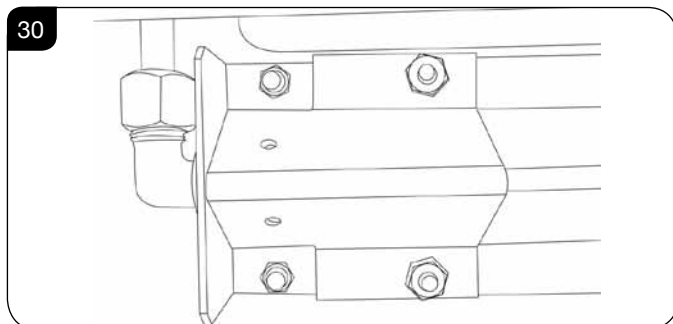

## 15. Changing Between Gas Types

In order to change between gas types, it will be necessary to change the following items:

**Burner Unit (Not Medium)**  
**Pilot Injector**  
**Control Valve**  
**Injector**  
**Aeration Plate (if required)**  
**Data Badge**

A kit of parts is available for this, always quote the Model number and Serial number when ordering any spare parts.

**NOTE: THE CONTROL VALVE IS FACTORY PRESET FOR THE CORRECT GAS TYPE AND MODEL, A NEW UNIT WILL NEED TO BE ORDERED WHEN CHANGING BETWEEN GAS TYPES.**

## 16. Pressure and Leak Testing the Appliance

- 16.1 Remove the decorative front and plinth - see Section 2.
- 16.2 Access to the pressure test point can now be reached, see Diagram 31.
- 16.3 Light the appliance and spray any joints with leak detector fluid.
- 16.4 Tighten joints or replace if required.

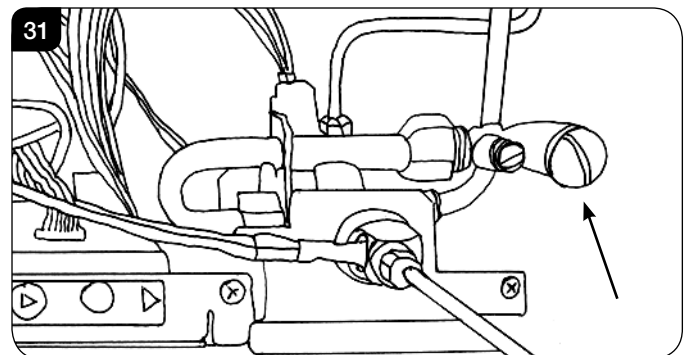

- 16.5 To check the inlet working pressure connect a manometer to the pressure test point, see Diagram 22. Operate the appliance at highest flame setting and check that the inlet pressure is in accordance with specifications detailed on page 15.



# Servicing Instructions - Replacing Parts

## 16. Short Spares List

COMPONENT	RIVA VISION SMALL		RIVA VISION MIDI		RIVA VISION MEDIUM	
	NG	LPG	NG	LPG	NG	LPG
PILOT INJECTOR	PI0026	PI0015	PI0026	PI0015	PI0069	PI0070
MAIN INJECTOR	IN0014	IN0071	IN0001	IN0065	IN0076	IN0068
AERATION PLATE	G20 - GZ9708	G31 - GZ3868	G20 - GZ3270	G31 - GZ2025	GZ10406	GZ11214
ELECTRODE	PI0053				PI0075	
THERMOCOUPLE	PI0011				PI0074	
MAG UNIT	GC0109					
IGNITION LEAD	EL0508					
CONTROL BOX	EL0575					
GAS VALVE	GC0170	GC0172	GC0170	GC0172	GC0170	GC0172
THERMOSTATIC REMOTE CONTROL	EL0574					
INTERRUPTOR BLOCK	GC0026					
INTERRUPTOR CABLE (3 Leads including TTB)	EL0064 EL0317 EL0543					
TOUCH PAD	EL0272					
TOUCH PAD LEAD	EL0273					
BATTERY HOLDER	EL0503					
BATTERY HOLDER CABLE	EL0533					
LH CERAMIC PANEL	CE1004		CE1013		-	
RH CERAMIC PANEL	CE1005		CE1014		-	
BACK CERAMIC PANEL	CE1006		CE1015		-	
TOP CERAMIC PANEL	CE1008		CE1016		-	
CERAMIC LOG SET	CE0953		CE0960		CE1304	
LH STAINLESS STEEL PANEL	-		-		GZ11014	
RH STAINLESS STEEL PANEL	-		-		GZ11015	
REAR VERMICULITE LINER	-		-		CE1311	
TOP VERMICULITE BAFFLE	-		-		CE1312	

# Service Records

**1ST SERVICE**

Date of Service .....  
Next Service Due .....  
Signed .....  
Retailer's Stamp/Gas Safe Registration Number

**3RD SERVICE**

Date of Service .....  
Next Service Due .....  
Signed .....  
Retailer's Stamp/Gas Safe Registration Number

**5TH SERVICE**

Date of Service .....  
Next Service Due .....  
Signed .....  
Retailer's Stamp/Gas Safe Registration Number

**7TH SERVICE**

Date of Service .....  
Next Service Due .....  
Signed .....  
Retailer's Stamp/Gas Safe Registration Number

**9TH SERVICE**

Date of Service .....  
Next Service Due .....  
Signed .....  
Retailer's Stamp/Gas Safe Registration Number

**2ND SERVICE**

Date of Service .....  
Next Service Due .....  
Signed .....  
Retailer's Stamp/Gas Safe Registration Number

**4TH SERVICE**

Date of Service .....  
Next Service Due .....  
Signed .....  
Retailer's Stamp/Gas Safe Registration Number

**6TH SERVICE**

Date of Service .....  
Next Service Due .....  
Signed .....  
Retailer's Stamp/Gas Safe Registration Number

**8TH SERVICE**

Date of Service .....  
Next Due .....  
Signed .....  
Retailer's Stamp/Gas Safe Registration Number

**10TH SERVICE**

Date of Service .....  
Next Service Due .....  
Signed .....  
Retailer's Stamp/Gas Safe Registration Number



**Gazco Limited, Osprey Road, Sowton Industrial Estate, Exeter, Devon, England EX2 7JG**  
**Technical Customer Services: (01392) 261950 Fax: (01392) 261951**  
**E-mail: [technicalservices@gazco.com](mailto:technicalservices@gazco.com)**

A member of the Stovax Group  
E & O E