



Fire Your Imagination

Riva2 800 & 1050

Balanced Flue with Thermostatic Remote Control and Dual Burner



Instructions for Use, Installation & Servicing

For use in GB & IE (Great Britain & Republic of Ireland).

IMPORTANT

THE OUTER CASING, FRONT AND GLASS PANEL BECOME EXTREMELY HOT DURING OPERATION AND WILL RESULT IN SERIOUS INJURY AND BURNS IF TOUCHED. IT IS THEREFORE RECOMMENDED THAT A FIREGUARD COMPLYING WITH BS 8423:2002 IS USED IN THE PRESENCE OF YOUNG CHILDREN, THE ELDERLY OR INFIRM.

This product contains a Heat resistant glass panel. This panel should be checked during Installation and at each servicing interval. If any damage is observed on the front face of the glass panel (scratches, scores, cracks or other surface defects), the glass panel must be replaced and the appliance must not be used until a replacement is installed. Under no circumstances should the appliance be used if any damage is observed, the glass panel is removed or broken.

It is essential that ALL of the screws that retain the glass frame are replaced and tightened correctly. Under no circumstances should the appliance be operated if any of these screws are loose or missing.

These Instructions must be left with the appliance for future reference and for consultation when servicing the appliance. Please make the customer aware of the correct operation of the appliance before leaving these instructions with them.

The commissioning sheet found on Page 3 of this Instruction manual must be completed by the Installer prior to leaving the premises.

Contents

Studio Balanced Flue

Covering the following models:

| Gas Type | Riva2 800 | | Riva2 1050 | |
|-----------------|--------------------|---------------------|--------------------|---------------------|
| | Vermiculite Lining | Black Reeded Lining | Vermiculite Lining | Black Reeded Lining |
| Nat. Gas | 134-099 | 134-110 | 134-136 | 134-178 |
| LPG | 134-412 | 134-461 | 134-493 | 134-544 |

| | |
|--|-----------|
| Appliance Commissioning Checklist | 3 |
| User Instructions | 4 |
| Installation Instructions | 14 |
| Technical Specifications | 14 |
| Site Requirements | 16 |
| Installation | 20 |
| Commissioning | 33 |
| Servicing Instructions..... | 34 |
| Fault Finding..... | 34 |
| How to Replace Parts | 36 |
| Basic Spare Parts List..... | 42 |
| Service Records | 44 |



To receive your Extended Warranty your Gazco appliance must have been purchased from our Expert Retailer Network and registered within one month of purchase or installation. Please note that all warranties are effective from the date of purchase. Any Gazco product purchased outside of our Extended Retailer Network, or not registered within the stated time will carry a standard 12 month warranty.

It is a condition of the Extended Warranty that the installation complies with the relevant Building Regulations and is carried out by a suitably trained and qualified individual (GasSafe in the UK or equivalent in other countries) with the certificate of installation and the Commissioning Report on Page 3 completed and retained by the end user.

Full terms and conditions are detailed in the Warranty Statement on the Gazco website www.gazco.com. In the event of any conflict of information the wording on the website shall prevail.

Important Note: Should any problems be experienced with your product, claims must first be submitted to the Expert Retailer where the appliance was purchased from who will offer immediate assistance or contact Gazco on your behalf.

Appliance Commissioning Checklist

To assist us in any guarantee claim please complete the following information:-

IMPORTANT NOTICE

Explain the operation of the appliance to the end user, hand the completed instructions to them for safe keeping, as the information will be required when making any guaranteed claims.

| FLUE CHECK | PASS | FAIL |
|---|-------------------|------|
| 1. Flue Is correct for appliance | | |
| 2. Flue flow Test | | |
| 3. Spillage Test | | |
| GAS CHECK | | |
| 1. Gas soundness & let by test | | |
| 2. Standing gas pressure | mb | |
| 3. Appliance working pressure (on High Setting NB All other gas appliances must be operating on full | mb | |
| 4. Gas rate | m ³ /h | |
| 5. Does Ventilation meet appliance requirements | | |
| SAFETY CHECK | | |
| 1. Glass checked to ensure no damage, scratches, scores or cracks. | | |
| 2. Glass frame secured correctly and all screws replaced | | |

RETAILER AND INSTALLER INFORMATION

| | |
|-----------------------|----------------------------|
| Retailer | Installation Company |
| | |
| | |
| Contact No..... | Engineer..... |
| Date of Purchase..... | Contact No..... |
| Model No. | Gas Safe Reg No. |
| Serial No..... | Date of Installation |
| Gas Type | |

User Instructions

Welcome

Congratulations on purchasing your Riva2 fire, if installed correctly Gazco hope it will give you many years of warmth and pleasure for which it was designed.

The purpose of this manual is to familiarise you with your appliance and give guidelines for its installation, operation and maintenance. If, after reading, you need further information, please do not hesitate to contact your Gazco retailer.

WARNING



In the event of a gas escape or if you can smell gas, please take the following steps:

- **Immediately turn off the gas supply at the meter/emergency control valve**
- **Extinguish all sources of ignition**
- **Do not smoke**
- **Do not operate any electrical light or power switches (On or Off)**
- **Ventilate the building(s) by opening doors and windows**
- **Ensure access to the premises can be made**

Please report the incident immediately to the National Gas Emergency Service Call Centre on 0800 111 999 (England, Scotland and Wales) , 0800 002 001 (N. Ireland) or in the case of LPG, the gas supplier whose details can be found on the bulk storage vessel or cylinder.

The gas supply must not be used until remedial action has been taken to correct the defect and the installation has been recommissioned by a competent person.

1. General

- 1.1 Installation and servicing must only be carried out by a competent person whose name appears on the Gas Safe register. To ensure the engineer is registered with Gas Safe they should possess an ID Card carrying the following logo:



- 1.2 In all correspondence, please quote the appliance type and serial number, which can be found on the data badge located on a plate attached to the lower slotted trim.
- 1.3 **Do not** place curtains above the appliance: You must have 300mm (1') clearance between the appliance and any curtains at either side.
- 1.4 No furnishings or other objects should be placed within 1 metre of the front of the appliance.
- 1.5 If a shelf is fitted, a distance of 400mm above the appliance is required.
- 1.6 If any cracks appear in the glass panel do not use the appliance until the panel has been replaced.
- 1.7 Do not obstruct the flue terminal in any way, i.e. by planting flowers, trees, shrubs etc. in the near vicinity, or by leaning objects against the terminal guard.
- 1.8 Do not put any objects on the terminal guard; it will lose its shape.
- 1.9 If you use a garden sprinkler, do not let quantities of water into the flue terminal.
- 1.10 In the unlikely event the appliance is receiving interference from other electronic devices, the handset/Control box can be reprogrammed. Please refer to the commissioning section in order to reprogram the handset.
- 1.11 This product is guaranteed for 5 years from the date of installation, as set out in the terms and conditions of sale between Gazco and your local Gazco retailer. Please consult with your local Gazco retailer if you have any questions. In all correspondence always quote the Model Number and Serial Number.



IMPORTANT : NEVER position an LCD/Plasma TV above this appliance.

User Instructions

2. Operating the Appliance

There are two ways of lighting the appliance:

1. Using the remote control handset, see Section 3.
2. Using the appliance's touch pad, see Section 4.

3. Thermostatic and Timer Remote Control

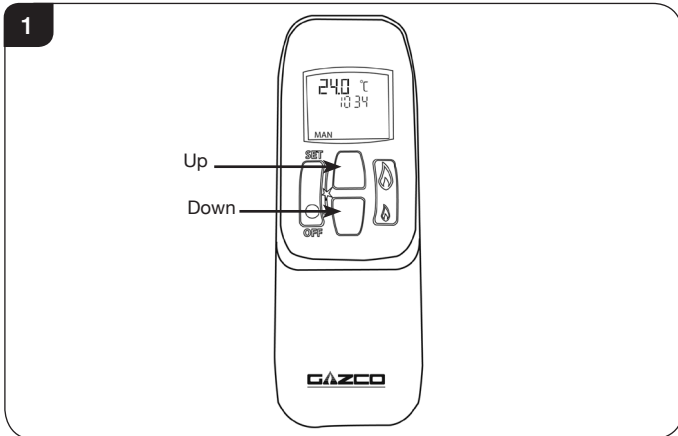

3.1 Turning the appliance On

The remote can control the gas appliance from pilot ignition through to shut down.

To turn the appliance on press the OFF button and the UP button simultaneously. Several short signals can be heard. **The pilot and main burner ignite and the remote is now in Manual Mode:**

IMPORTANT: YELLOW FLAMES TYPICALLY APPEAR WHEN THE APPLIANCE HAS REACHED NORMAL OPERATING TEMPERATURE. THIS CAN TAKE UP TO 30 MINUTES.

WARNING: IF THE APPLIANCE FAILS TO LIGHT OR BECOMES EXTINGUISHED IN USE, WAIT 3 MINUTES BEFORE ATTEMPTING TO RELIGHT.

3.2 There are 3 different modes available for controlling and operating the appliance:

1. Manual Mode
2. Temp Mode (Automatic)
3. Timer Mode (Automatic)

3.3 In **MANUAL MODE** you can:

Turn on the burners using the UP button.
Regulate the flame from high to low and back.
Switch between dual and single burners.
Turn off both burners leaving just the pilot burning .

In **TEMP MODE (Automatic)** you can:

Set the room temperature so the thermostat in the remote automatically maintains that temperature.

In **TIMER MODE (Automatic)** the appliance:

Turns on and off according to the set time periods.

Automatically regulates the room temperature during the set periods.



NOTE: When operating the appliance in Temp or Timer mode, the pilot remains lit and the appliance then automatically switches on at programmed times to bring the room to the set temperature whether or not you are in the room. NEVER LEAVE ANY COMBUSTIBLE MATERIALS WITHIN 1 METRE OF THE FRONT OF THE APPLIANCE.

Advanced Controls

3.4 The LCD screen displays the following information, see Diagram 2.

- 1) °C/24 hour or °F/12 Hour Clock
- 2) Signal strength (between handset and appliance)
- 3) Battery Status
- 4) Time Setting
- 5) Dual/Single Burner Select
- 6) Selected mode - Manual Flame / Fixed Temp (Auto) / Program - when appliance is switched on
- 7) Program Timer Setting
- 8) ON/OFF Temperatures setting
- 9) Temperature Setting

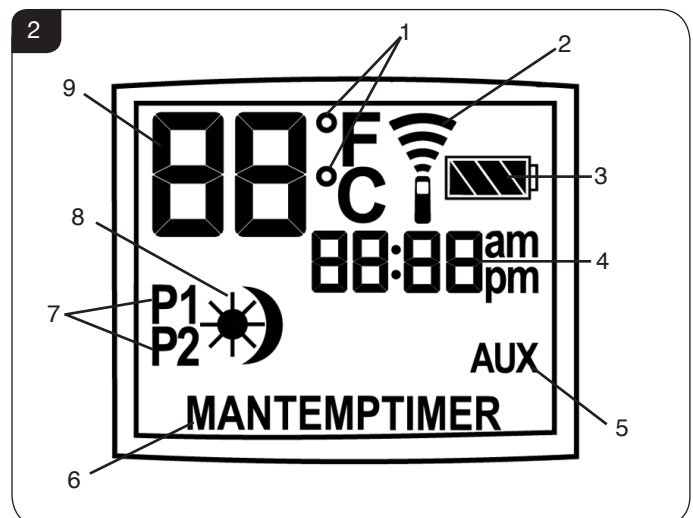

User Instructions

Switching Between Modes

- 3.5 Press the SET button to change to Temperature Mode. Press again to change to Timer Mode. Keep pressing to run through all operating modes.

These are:
MAN
DAY TEMP
NIGHT TEMP
TIMER
and back to MAN

NOTE: MAN mode can also be reached by pressing either the UP or DOWN button.

Setting the Time

- 3.6 The Time display will flash after either:
a) Installing the battery
b) Simultaneously pressing the UP and DOWN buttons.

Press the UP button to set the **HOUR**.
Press the DOWN button to set the **MINUTE**.
Press OFF or wait for the remote to return to **MAN mode**.

Setting the °C/24 Hour or °F/12 Hour clock

- 3.7 Press OFF and the down arrow until the display changes from °C/24 hour clock to °F/12 hour clock and vice versa.

Manual Mode

- 3.8 Press the OFF button and the UP button simultaneously. Several clicks and audible beeps will sound as the appliance begins the ignition process, (up to 30 seconds). The burner will light in the High position.

Turning the appliance Off:

Press the OFF button to turn the appliance off.

FOR SAFETY, WAIT 30 SECONDS BEFORE LIGHTING THE APPLIANCE AGAIN.

Increasing the Flame Height:

Press and hold the UP button to increase to maximum.

Decreasing the Flame Height:

Press and hold the DOWN button to decrease to minimum. At the lowest point the appliance goes to 'Standby Mode' (Only Pilot lit).

Designated Low and High Flame Positions:

Press the DOWN button twice to put the appliance into the designated low position. 'LO' will be displayed on the handset.
NOTE: The flame will go to the designated high position before going to the low setting.

Press the UP button twice to put the appliance into the designated High position. 'HI' will be displayed on the handset.



NOTE: While pressing a button a symbol indicating transmission appears on the display. The receiver confirms transmission with a sound signal.

Temp Mode (Automatic)

- 3.9 The display shows the current **room** temperature.

To increase or decrease the appliance output:

Press the **SET** button to select either the **DAY TEMP** or the **NIGHT TEMP** mode by briefly pressing the SET button.

Hold the **SET** button until the **TEMP** display flashes and then let go.

Set the desired temperature with the UP and DOWN arrows. (Minimum temperature 5C, maximum 40C or 40F to 99F when Fahrenheit is the preferred option)

Press the OFF button to stop the display flashing or wait to return to TEMP mode.



NOTE: If a temperature is set that is beneath the current room temperature, the appliance automatically switches to PILOT (Stand by).

To turn the Night temperature control off then decrease the temperature until [--] is displayed.

Timer Mode (Automatic)

- 3.10 There are two programmable settings that can be set over a 24 hour period, P1 and P2. These are normally used to provide an early morning and evening setting for each working week:

P1 + ● = Start Timed Setting 1
P1 + ☞ = End of Timed Setting 1
P2 + ● = Start Timed Setting 2
P2 + ☞ = End of Timed Setting 2

- 3.11 **P1 - Program 1 for a Timed Setting**

Press the SET button until the TIMER mode is displayed.

Hold the SET button. The displays flashes the current time for P1. **While the time displayed is flashing you can alter the hours and minutes set.**

To set the time the appliance first lights, change P1 ●
Press the **UP** button to alter the **HOUR**.
Press the **DOWN** button to alter the **MINUTES** in 10 minute increments.

Press **SET** again to move to the end setting for P1 ☞ This is the time the appliance first shuts down:
Press the **UP** button to alter the **hour**.
Press the **DOWN** button to alter the **MINUTES**.

User Instructions

3.12 P2 - Program 2 for a Timed Setting

Use the same steps outlined in 3.11 to change the setting for P2.

If P1 is already set and only P2 needs to change:

Press the **SET** button until **TIMER** mode is displayed. Hold the **SET** button until the display flashes the current time for P1. Press the **SET** button once again to scroll past the settings for P1 and P1.

With the time still flashing:

Press the UP button to alter the **HOUR**.
Press the DOWN button to alter the **MINUTES**.

Once all four times are set press the OFF button.

3.13 To view existing settings:

Select **TIMER MODE**.

Press and briefly hold the **SET** button the start time for P1 will be displayed.

Repeat the above step for the start and end of each program.

Low Battery

- 3.14 The handset has a low battery indicator on the display when its batteries need replacement. Battery replacement is recommended after 1 year.

Dual Burners - Riva2 and Eclipse models only

- 3.15 Upon ignition, the appliance will light in the position it was last set to; for example, if it was last set to rear burner only, it will relight in this position. With the handset it is also possible to turn off the front burner and use the appliance with just the rear burner operating.

Press **SET** and the **DOWN** button simultaneously to switch the front burner **OFF**.

Press **SET** and the **UP** button simultaneously to switch the front burner **ON**.

This operation is blocked when in Timer OFF mode and the night time set back temperature is set to "-". It is not possible to independently control the flame height between the rear and front burners. It is however possible to control the flame height of the rear burner when the front burner is turned off allowing a reduced minimum input position.



Transmission Interference on Handset

Your remote has been factory set. If your property, or adjacent properties, contain appliances using the same control system, it may be necessary to change the transmission code of your handset. See User and Installation Instructions for the fire.

4. Touchpad Control

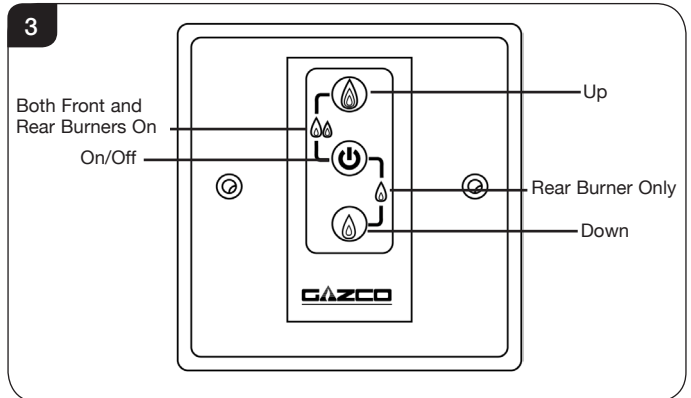

- 4.1 Press and hold the On/Off button until a short beep confirms the start up sequence has begun. Continuing beeps confirm the ignition process is in process. The appliance will light in the High flame position.
- 4.2 Press UP button to increase the flame height. Press the DOWN button to decrease the flame height. At the lowest point it goes to 'standby mode', (only pilot lit). Press the ON-OFF button again to turn the appliance off.

Dual Burners - Riva2 and Eclipse models only

- 4.3 To operate the dual burner controls, press the **On/Off** button and **DOWN** button simultaneously to **turn the front burner off**. Press the **On/Off** button and **UP** button simultaneously to turn the **front burner on**.

The flame height can be adjusted in either the single or dual burner modes by the using the UP and DOWN buttons.

Press and hold the On/Off button to turn the appliance off.



IMPORTANT: YELLOW FLAMES TYPICALLY APPEAR WHEN THE APPLIANCE HAS REACHED NORMAL OPERATING TEMPERATURE. THIS CAN TAKE UP TO 30 MINUTES.



WARNING: IF THE APPLIANCE FAILS TO LIGHT OR BECOMES EXTINGUISHED IN USE, WAIT 3 MINUTES BEFORE ATTEMPTING TO RELIGHT.

Low Battery

- 4.4 If the receiver is not being powered by a mains adapter and the batteries are low it will emit frequent beeps for 3 seconds as the motor turns. The system will shut off the fire completely if the battery power gets too low.

User Instructions

Emergency Shut Off

- 4.5 If the batteries fail during use of the appliance, move the switch to the OFF (O) position, see Diagram 4.
(This switch is set to be ON during normal operation and must remain ON)
- 4.6 To operate the switch insert a thin screwdriver through the semi circular cut out in the lower slotted trim. The switch is located on the right hand side of the appliance under the slotted trim.

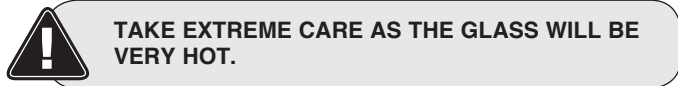

TAKE EXTREME CARE AS THE GLASS WILL BE VERY HOT.

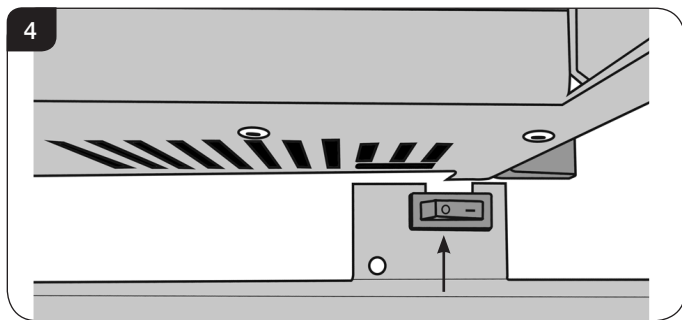

- 4.7 If the temperature in the reciever is higher than 60°C (140°F) then the appliance will go into Standby mode (Pilot only) until the temperature drops below 60°C.

5. Cleaning the appliance

Make sure the fire and surrounds are cool before cleaning.

- 5.1 Use a damp cloth to clean the painted frame and use soap and water for the glass.
- Clean the burner using a vacuum cleaner with a soft brush attachment. Ensure all debris is removed from the burner ports.
In the unlikely event soot is deposited on the logs, use a soft brush to remove.
- 5.2 To remove the glass frame, first remove the side trims, see Diagram 5.



These are held on by magnets.

- 5.3 Lift out the bottom slotted trim, see Diagram 6.

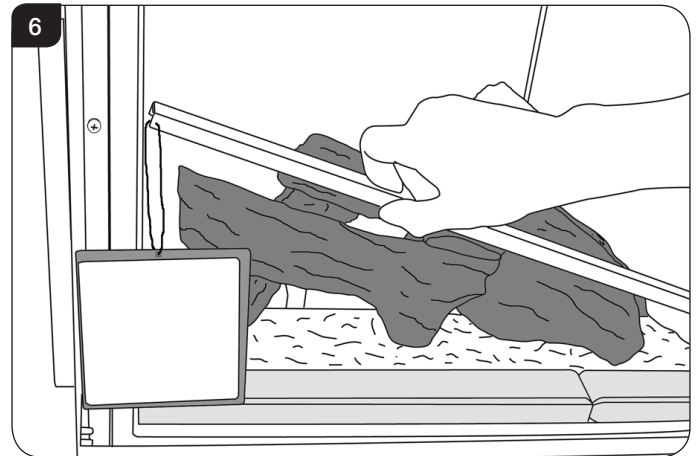

- 5.4 Remove all the screws around the glass frame. (10 on the 800 model and 9 on the 1050 model)
Please note: The screws are located down both sides and along the bottom edge of the glass frame.
- 5.5 Lift the glass frame using the handle, up and over the lower edge. Take extreme care not to damage the paint, Diagram 7.

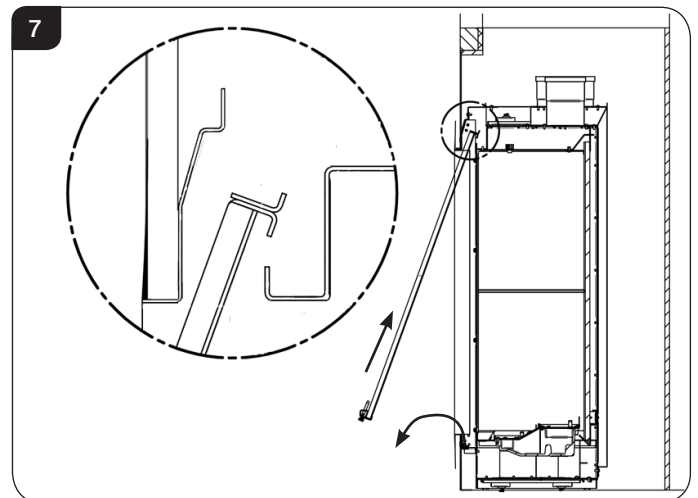

- 5.6 Lower the frame - the top edge will be hooked onto the top of the appliance.
- 5.7 Hold the sides of the frame and lift approximately 25mm and pull the top forward. This will release the door - Lower to clear the appliance.
- 5.8 To replace the glass frame place in position and tilt the bottom forward whilst ensuring the top hooks over the lip on the top of the appliance, see Diagram 7.
- 5.9 **Replace ALL of the glass frame securing screws ensuring that a screw is present in all fixing slots (10 in the Riva2 800 and 9 on the Riva2 1050).**
Tighten each of the screws in the bottom of the frame first and work up the Left and Right hand sides tightening each of the screws in turn, see Diagram 8a and 8b.

User Instructions

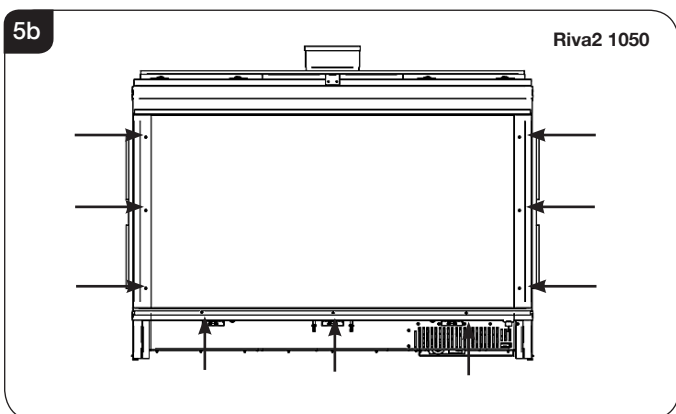
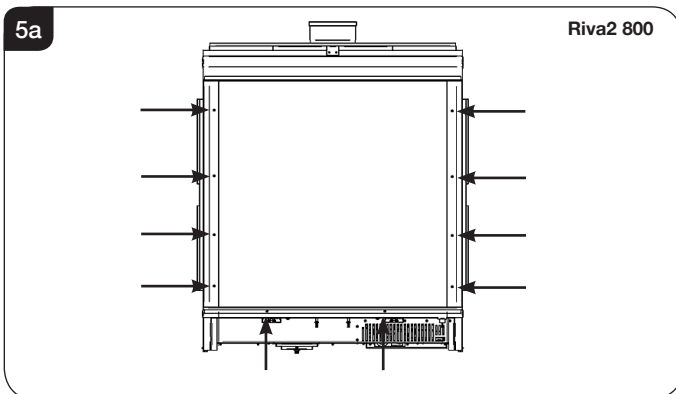

! UNDER NO CIRCUMSTANCES SHOULD THE APPLIANCE BE USED IF ANY OF THE GLASS FRAME RETAINING SCREWS ARE LOOSE OR MISSING.

6. Changing the appliance batteries

The appliance batteries are located behind the wall switch plate.

- 6.1 Undo the two screws securing the wall switch and plate and remove, see Diagram 9.

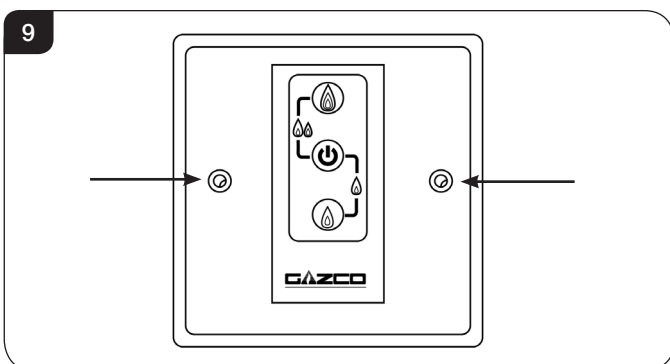

- 6.2 Unclip the battery holder from the wall switch and remove the old batteries.
- 6.3 Correctly position the four new AA size batteries into the battery holder. Re-assemble the battery holder as shown in Diagram 10.

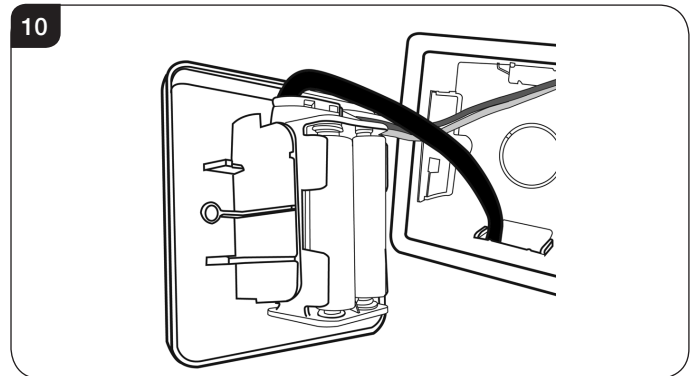

! PLEASE ENSURE NO WIRES ARE TRAPPED BEFORE REPLACING THE WALL PLATE. THE TOUCH PAD LEAD IS EASILY DAMAGED.

7. Arrangement of the fuel bed

Advice on handling and disposal of fire ceramics

! The fuel effect of the log version of this appliance is made from Refractory Ceramic Fibre (RCF), a material which is commonly used for this application.

Protective clothing is not required when handling these articles, but we recommend you follow normal hygiene rules of not smoking, eating or drinking in the work area and always wash your hands before eating or drinking.

To ensure that the release of RCF fibres are kept to a minimum, during installation and servicing a HEPA filtered vacuum is recommended to remove any dust accumulated in and around the appliance before and after working on it. When servicing the appliance it is recommended that the replaced items are not broken up, but are sealed within heavy duty polythene bags and labelled as RCF waste.

RCF waste is classed as stable, non-reactive hazardous waste and may be disposed of at a licensed landfill site.

Excessive exposure to these materials may cause temporary irritation to eyes, skin and respiratory tract; wash hands thoroughly after handling the material.

7.1 Vermiculite for Logs Layout

Use the entire bag of supplied Vermiculite. **TAKE CARE NOT TO SPILL VERMICULITE INTO THE PILOT AREA. ONLY VERMICULITE SUPPLIED BY GAZCO SHOULD BE USED IN THIS FIRE.**

User Instructions

8. Log Layout

LOGS MUST BE POSITIONED ACCORDING TO THE FOLLOWING INSTRUCTIONS TO GIVE THE CORRECT FLAME EFFECT.

- 8.1 Use all the vermiculite to fill the burner tray and spread evenly across the whole burner - The centre ramp does not have vermiculite on it. Spread evenly over the side and front panels (base). **Take care not to block the air gap around the burner.** Cover burner area **BEFORE** doing the panel decoration ensuring it is well covered - Avoid getting Vermiculite dust on the burner.

The logs are identified with letters A - H on the underside or rear of the log. A, B, C, D and G have holes to locate the logs on the pins fixed to the burner skin, Diagram 9.

Logs E and F have interlocking recesses which locate with logs B and D. H has no locations but will rest in a specific position.

There are two bags of effect material. One consists of black embers, the other is a special pack of Embaglow. This looks like wire wool and is placed after the logs are arranged.

- 8.2 Locate Log A on the pin in front of the pilot. Ensure the left hand side of the log rest on the upper part of the burner, see Diagram 11.

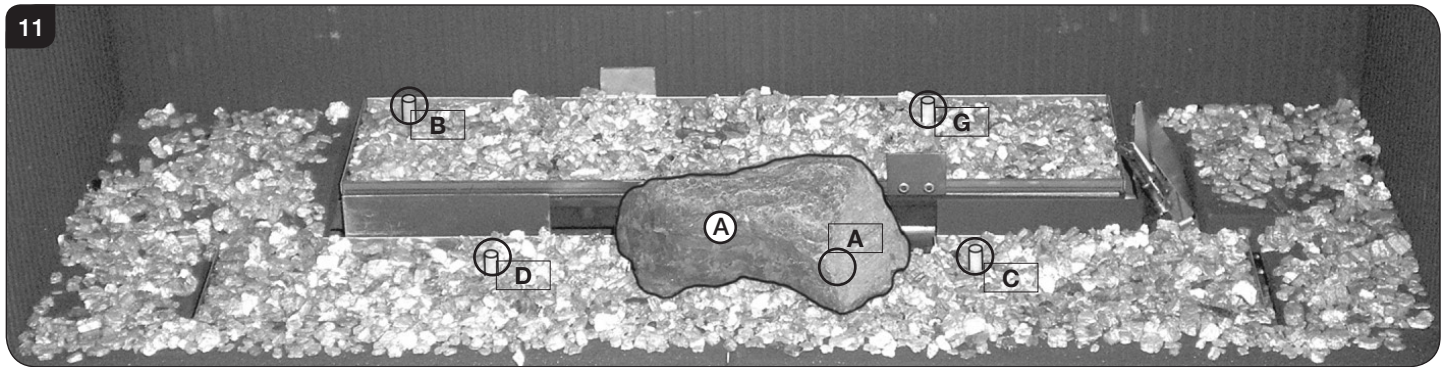

- 8.3 Locate Log B on the top left hand pin. The end of the log nearest the front of the appliance will rest on the side liner on the 800 model. On the 1050 model a distance of 25-30mm between the front left corner of the burner and the log is required, see Diagram 12.

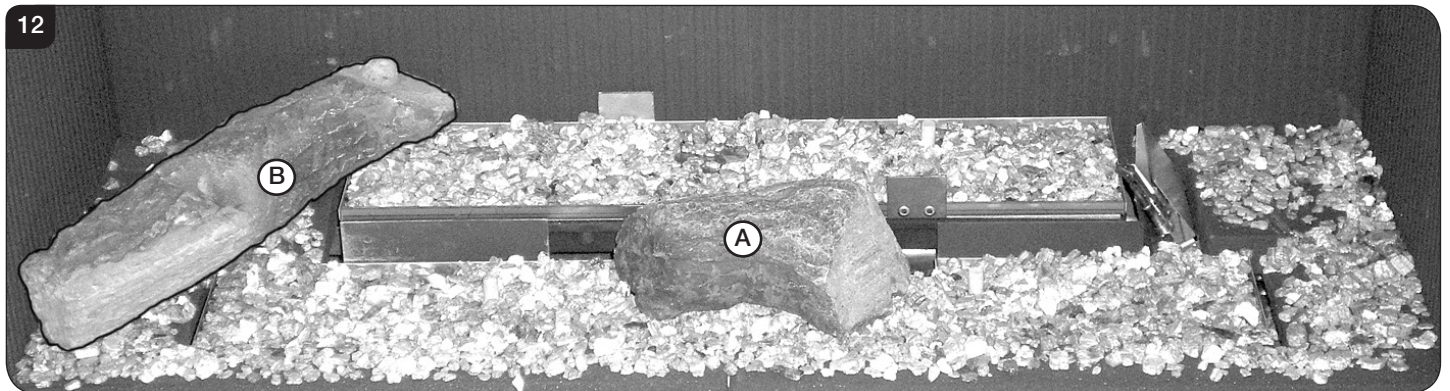

- 8.4 Locate Log C on the lower burner right hand pin. The rear of the log should touch the Pilot Shield at the end of the rear burner, see Diagram 13.



User Instructions

- 8.5 Locate Log D on the lower left hand pin. The hole is in the short branch of the log. The left hand side of the log sits in the groove on Log B, see Diagram 14.

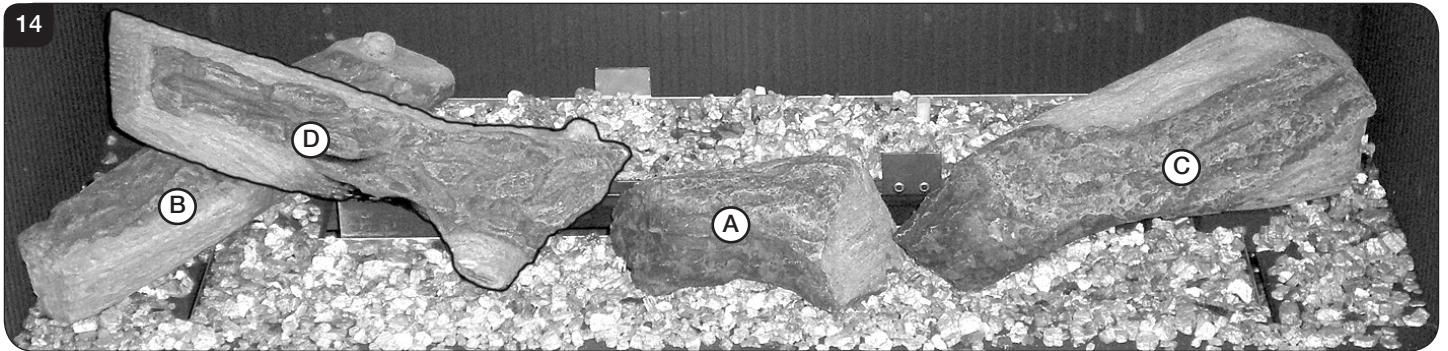

- 8.6 Place Log E on top of Log D. Engage the raised location into the recess on Log E. The rear of the log pushes against the right side of the raised tag on the rear of the burner, see Diagram 15.

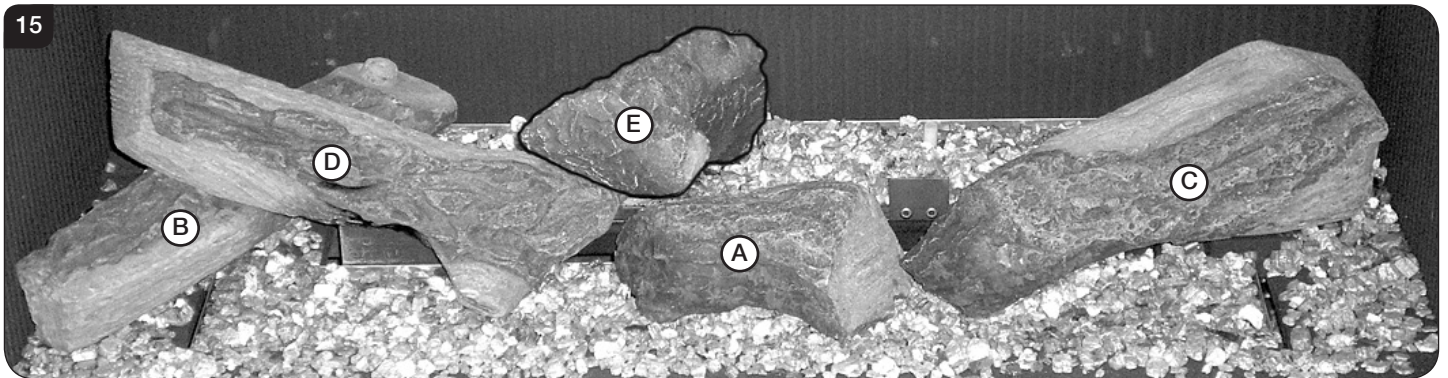

- 8.7 Place Log F on top of Log B and engage the raised locator into the recess on Log F. The right end of the log pushes against the raised tag on the rear of the burner, see Diagram 16.

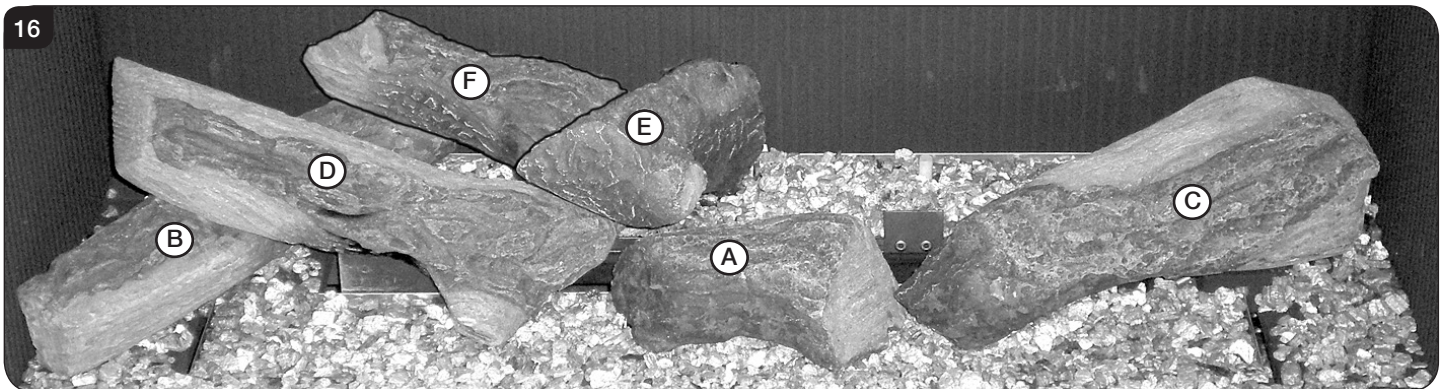

- 8.8 Place Log G on the remaining pin. The charred effect faces forward and the rear of the log rests against the Pilot Shield on the edge of the burner tray, see Diagram 17.

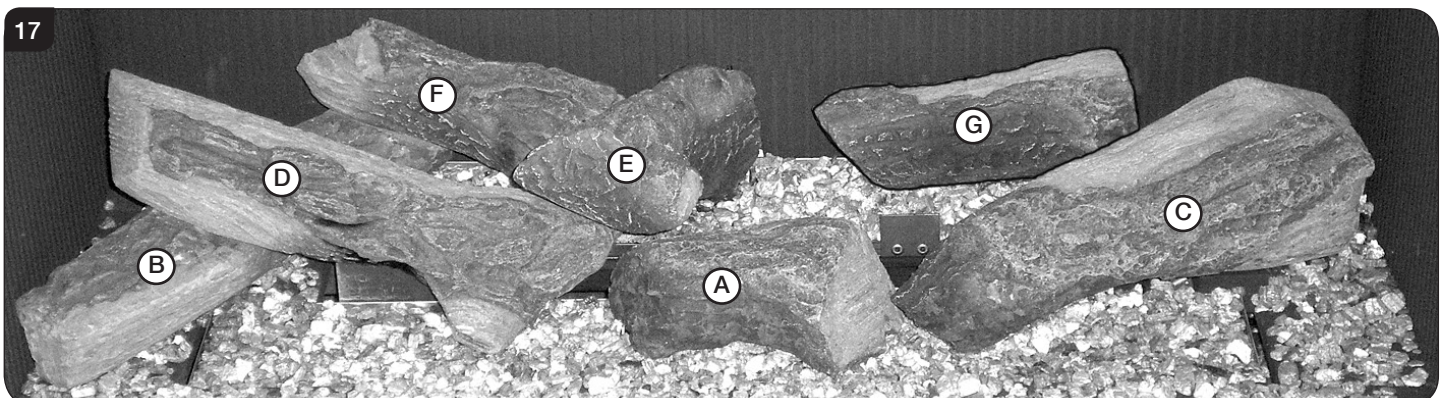

User Instructions

8.9 Log H locates on three points. The short branch locates in the recess on the Left Hand side of Log G. The main body of Log H rests on Log E and the front charred area of Log H rests between Log A and C on the raised tag, see Diagram 18.

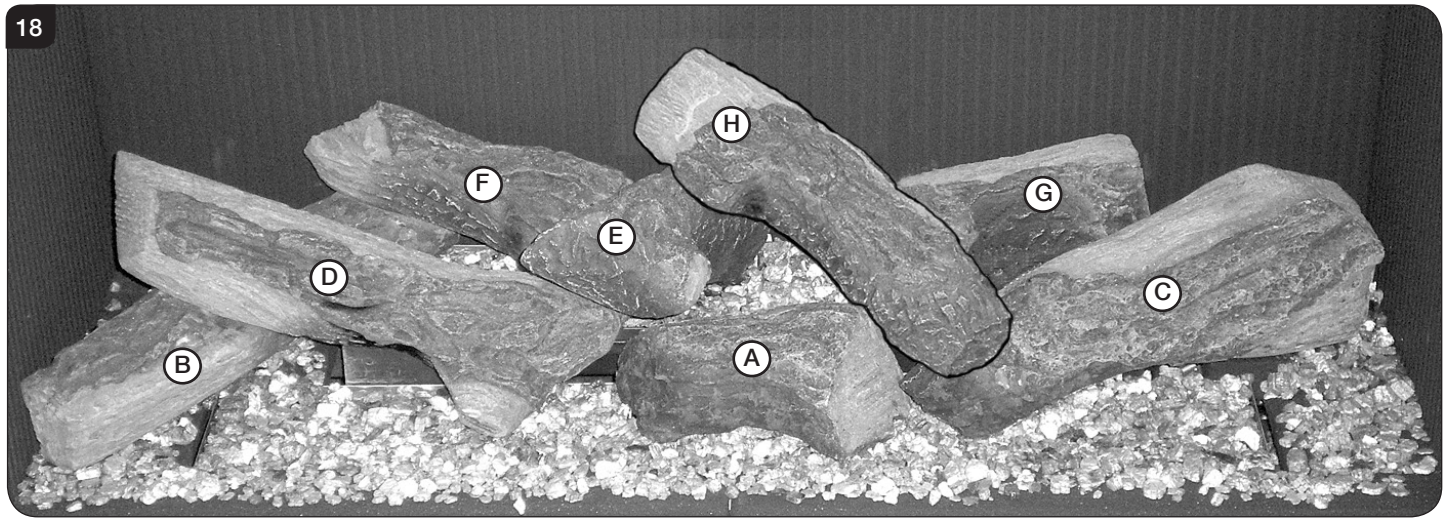

8.10 Place some of the black embers underneath the logs C and D on the front burner only. A few embers are placed between Logs D, A and C. Scatter a few embers in front of long logs B & C on the side panels. For best effect ensure no black embers are forward of the log front faces, see Diagram 19. **Take care not to block the air gap around the burner.**

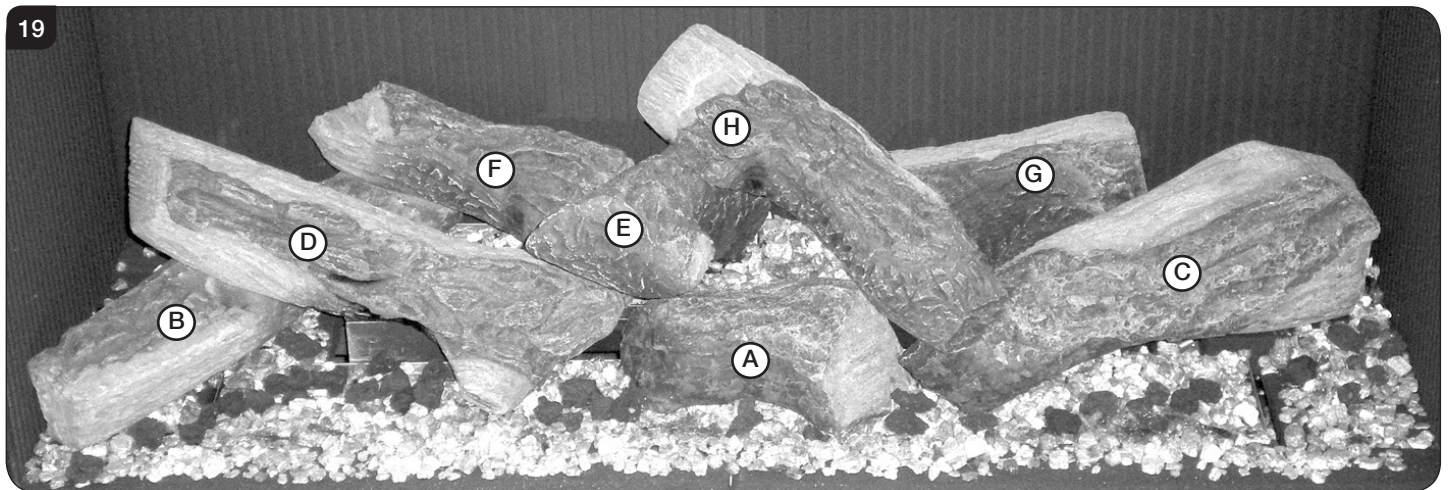

8.11 Lastly locate the Embaglow wire wool. Take care when positioning to ensure the best final effect.
NOTE: ONLY HALF THE MATERIAL SUPPLIED IS USED.

Separate half the material by hand and place the remainder back in the bag - the customer must keep this for use in the future. The material must be pulled into shape until only a very thin layer is applied onto the burner - too much material being used can diminish the flame effect.

The size of each piece is approximate. Loose strands of material can be trimmed with a pair of scissors. This will make it easier to apply.

There are six areas the Embaglow is placed in. Ensure it does not overhang the front of the burner, see Diagram 20 and 21.

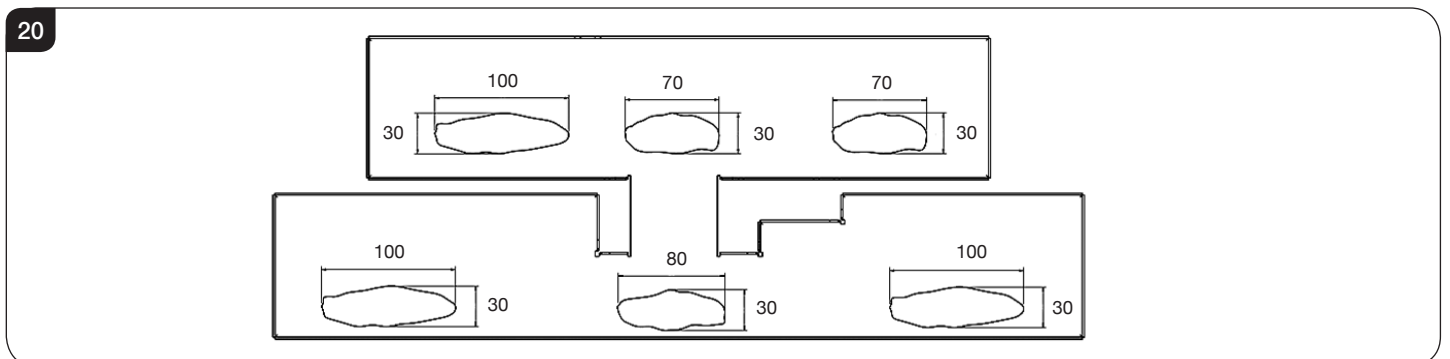

21

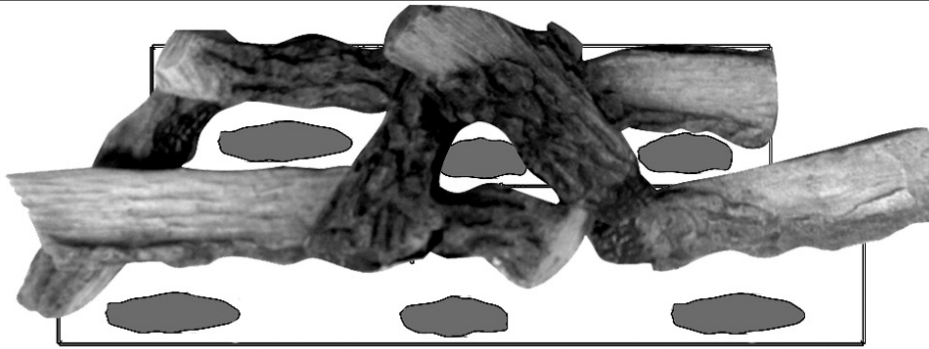

NOTE: This material will last approximately 500 hours burning. It is a consumable part and should be replaced when necessary. It can be purchased from your local dealer, Part No. GZ8471.

9. Flame Failure Device

- 9.1 This is a safety feature incorporated on this appliance which automatically switches off the gas supply if the pilot goes out and fails to heat the thermocouple.

IF THIS OCCURS DO NOT ATTEMPT TO RELIGHT THE APPLIANCE FOR 3 MINUTES.

10. Running In

- 10.1 During initial use of a new GAZCO appliance a strong odour will be encountered as various surface coatings become hot for the first time. Although these odours are harmless it is recommended that the appliance is operated on maximum for 4 to 8 hours in order to fully burn off these coatings. After this period the odours should then disappear.

If the odours persists, please contact your installer for advice.

- 10.2 During the first few hours of burning there may be discolouration of the flames. This will also disappear after a short period of use.

11. Servicing

- 11.1 The appliance must be serviced every 12 months by a qualified Gas Engineer. In all correspondence always quote the Model number and the Serial number which may be found on the data badge.

12. Ventilation

- 12.1 Any purpose provided ventilation should be checked periodically to ensure that it is free from obstruction.

13. Installation Details

- 13.1 Your installer should have completed the commissioning sheet at the front of this book. This records the essential installation details of the appliance. In all correspondence always quote the Model number and Serial number.

14. Hot Surfaces

- 14.1 Parts of this appliance become hot during normal use.
14.2 Regard all parts of the appliance as a working surface.
14.3 Provide a suitable fire guard to protect young children and the infirm.

15. Appliance will not light

If you cannot light the appliance:

- 15.1 Check and change the batteries in the remote handset.
15.2 Check and change the wall switch batteries (see Section 4).
15.3 Consult your Gazco retailer or installer if the appliance still does not light.

Installation Instructions

Technical Specification

Covering the following models:

| Gas Type | Riva2 800 | | Riva2 1050 | |
|-----------------|--------------------|---------------------|--------------------|---------------------|
| | Vermiculite Lining | Black Reeded Lining | Vermiculite Lining | Black Reeded Lining |
| Nat. Gas | 134-099 | 134-110 | 134-136 | 134-178 |
| LPG | 134-412 | 134-461 | 134-493 | 134-544 |

| Model | Gas CAT. | Gas Type | Working Pressure | Aeration | Injector | Gas Rate m ³ /h | Input kW (Gross) | | Country |
|--|------------------|---------------|------------------|--------------------------------------|-------------------------|----------------------------|------------------|-----|---------|
| | | | | | | | High | Low | |
| Riva2 800 BF | I ₂ H | Natural (G20) | 20mbar | Front: 1 x 7mm Ø Rear: 1 x 12mm Ø | Front: 300 Rear: 440 | 0.891m ³ /hr | 9.5 | 3.9 | GB, IE |
| Riva2 800 BF | I ₃ P | Propane (G31) | 37mbar | Front: 2 x 10mm Rear: Open | Front: 95 Rear: 120 | 0.316m ³ /hr | 8.8 | 3.5 | GB, IE |
| Riva2 1050 BF | I ₂ H | Natural (G20) | 20mbar | Front: 1 x 7mm Ø Rear: 1 x 12mm Ø | Front: 300 Rear: 440 | 0.891m ³ /hr | 9.5 | 3.9 | GB, IE |
| Riva2 1050 BF | I ₃ P | Propane (G31) | 37 mbar | Front: 2 x 10mm Rear: Open | Front: 95 Rear: 120 | 0.316m ³ /hr | 8.8 | 3.5 | GB, IE |
| Efficiency Class 1 - 82% / NO_x Class 5 | | | | | | | | | |
| Flue Outlet Size Ø 150mm | | | | | | | | | |
| Flue Inlet Size Ø 100mm | | | | | | | | | |
| Gas Inlet Connection Size Ø 8mm | | | | | | | | | |

i The net efficiency of this appliance has been measured as specified in EN613:2001 and the result after conversion to gross using the appropriate factor from Table E4 of SAP 2009 is 73.8%. The test data has been certified by Kiwa Nederland BV. The gross efficiency value may be used in the UK Government's Standard Assessment Procedure (SAP) for energy rating of dwellings.

| RESTRICTOR REQUIREMENT | | | | | |
|----------------------------|-------------------|-----------------|----------------------------|-------------------|-----------------|
| VERTICAL & HORIZONTAL FLUE | | | VERTICAL & HORIZONTAL FLUE | | |
| RIVA2 800 BF | | | RIVA2 1050 BF | | |
| Vertical Flue Height | Horizontal Length | Restrictor Size | Vertical Flue Height | Horizontal Length | Restrictor Size |
| 200mm - 500mm | Up to 500mm | No restrictor | 500mm - 990mm | Up to 500mm | No restrictor |
| 500mm - 1000mm | Up to 1000mm | No restrictor | 1000mm - 1490mm | Up to 1000mm | No restrictor |
| 1000mm - 1490mm | Up to 1000mm | No restrictor | 1500mm - 1990mm | Up to 5000mm | No restrictor |
| 1500mm - 1990mm | Up to 5000mm | No restrictor | 2000mm - 3000mm | Up to 5000mm | 75mm Ø |
| 2000mm - 3000mm | Up to 5000mm | 75mm Ø | | | |

| RESTRICTOR REQUIREMENT | |
|---|-----------------|
| TOP EXIT - VERTICAL ONLY INCLUDING OFFSET | |
| RIVA2 BF 800 and 1050 | |
| Vertical Flue Height | Restrictor Size |
| 3000 - 4990mm | 60mm Ø |
| 5000mm - 10,000mm | 52mm Ø |

Installation Instructions

Technical Specification

This appliance has been certified for use in countries other than those stated. To install this appliance in these countries, it is essential to obtain the translated instructions and in some cases the appliance will require modification. Contact Gazco for further information.

PACKING CHECKLIST

| Qty Description | Fixing Kit containing:- |
|---|--------------------------|
| 1 Log Set including Ember Pack | 1 x Instruction Manual |
| 1 Vermiculite Pack | 1 x Handset |
| 1 Chimney Renovation Kit | 4 x AA cell batteries |
| Front Cover (Left Hand) | 1 x 9V cell batteries |
| | 1 x wall box |
| 1 Chimney Renovation Kit Front Cover (Right Hand) | 2 x wall plate screws |
| | 1 x touch pad/wall plate |
| 2 Chimney Renovation Kit Rear Cover | 1 x battery holder |
| | 1 x Embaglow pack |
| 8 Fixing Screws (for Chimney Renovation Kit Cover Plates) | |

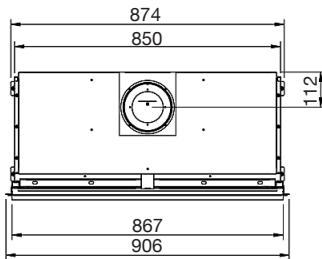

Riva2 800

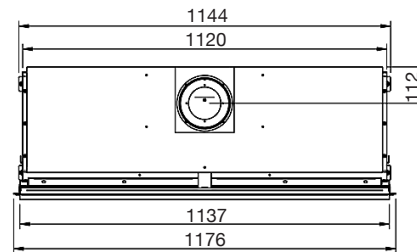

Riva2 1050

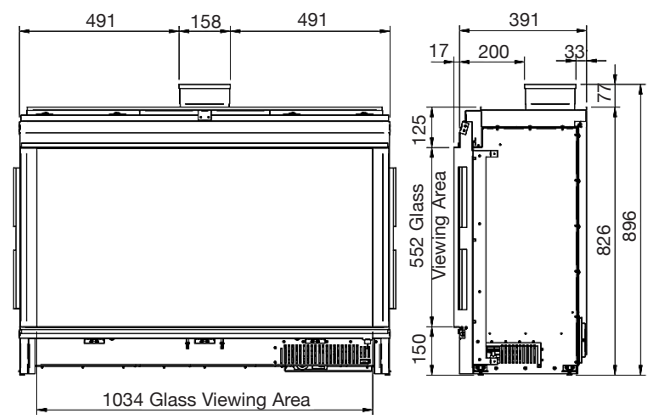
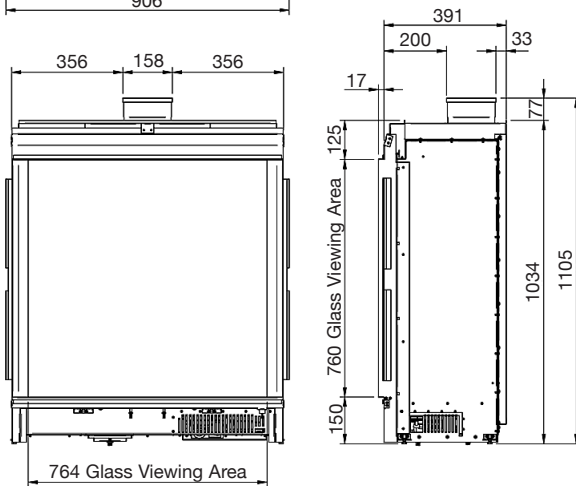

Installation Instructions

Site Requirements

1. Flue & Chimney Requirements

Note: This appliance must only be installed with the flue supplied.

You must adhere to the following:

- 1.1 The flue must be sited in accordance with BS5440: Part 1 (latest edition), see Diagram 1.
- 1.2 Fit a guard to protect people from any terminal less than 2 metres above any access such as level ground, a balcony or above a flat roof.
- 1.3 All vertical and horizontal flues must be securely fixed and fire precautions followed in accordance with local and national codes of practice.
- 1.4 A restrictor may be required, see Technical Specifications on page 14.
- 1.5 Two types of flue terminals are available, horizontal and vertical.

- 1.6 To measure for a horizontal terminal decide on the terminal position.
- 1.7 Measure the height from the top of the appliance to the centre of the required outlet.
- 1.8 For minimum and maximum flue dimensions see Diagrams 2 & 3.
- 1.9 Allow enough room either above or to the side of the appliance to assemble the flue on top.
- 1.10 Assemble a horizontal flue in the following order:
 - Vertical section
 - 90° elbow
 - Horizontal plus terminal
- 1.11 Support the opening of a masonry installation with a lintel.
- 1.12 Only the horizontal terminal section can be reduced in size.

1 UK Dimensions

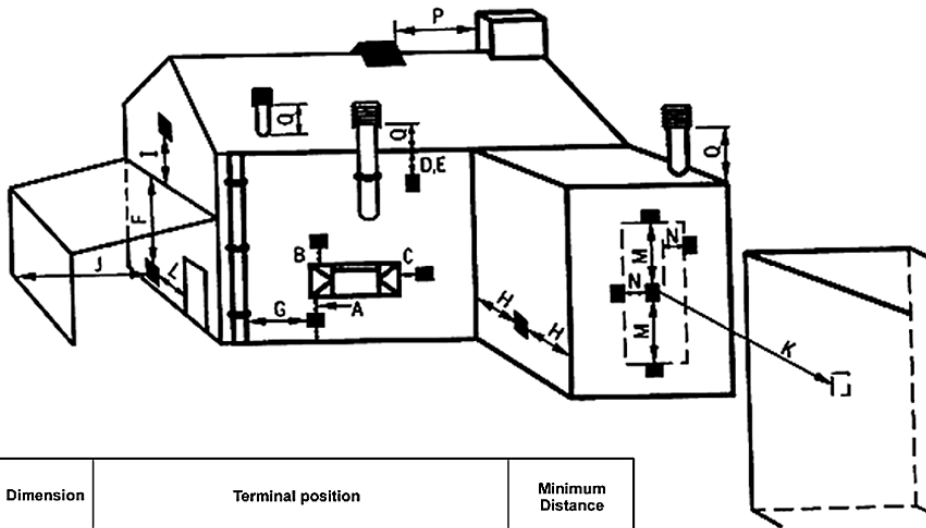

| Dimension | Terminal position | Minimum Distance |
|-----------|---|------------------|
| A* | Directly below an opening, air brick, opening windows, etc. | 600mm |
| B* | Above an opening, air brick opening windows, etc. | 300mm |
| C* | Horizontally to an opening, air brick opening windows etc. | 400mm |
| D | Below gutters, soil pipes or drain pipe | 300mm |
| E | Below eaves | 300mm |
| F | Below balconies or car port roof | 600mm |
| G | From a vertical drain pipe or soil pipe | 300mm |
| H | From an internal or external corner | 600mm |
| I | Above group roof or balcony level | 300mm |
| J | From a surface facing the terminal (also see 6.1.2) | 600mm |
| K | From a terminal facing the terminal | 600mm |
| L | From an opening in the car port (e.g. door, window) into the dwelling | 1200mm |
| M | Vertically from a terminal on the same wall | 1500mm |
| N | Horizontally from a terminal on the same wall | 300mm |
| O | From the wall on which the terminal is mounted | N/A |
| P | From a vertical structure on the roof | 600mm |
| Q | Above intersection with roof | 300mm |

* In addition, the terminal should not be nearer than 300mm to an opening in the building fabric formed for the purpose of accommodating a built-in element such as a window frame

Installation Instructions

Site Requirements

2. Flue Options

RIVA2 800 BF

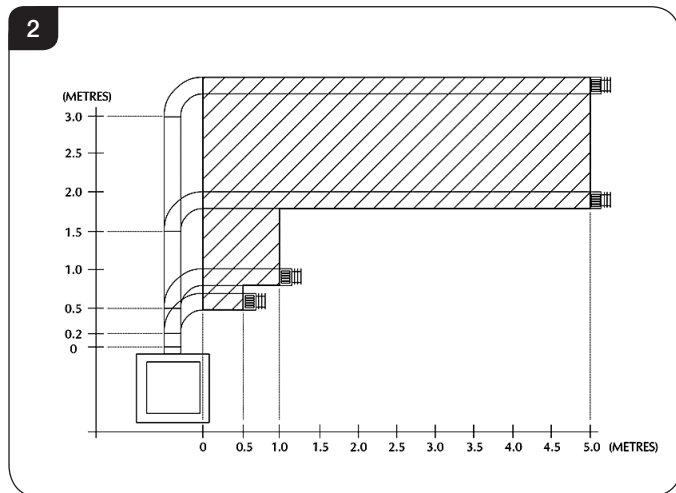

RIVA2 1050 BF

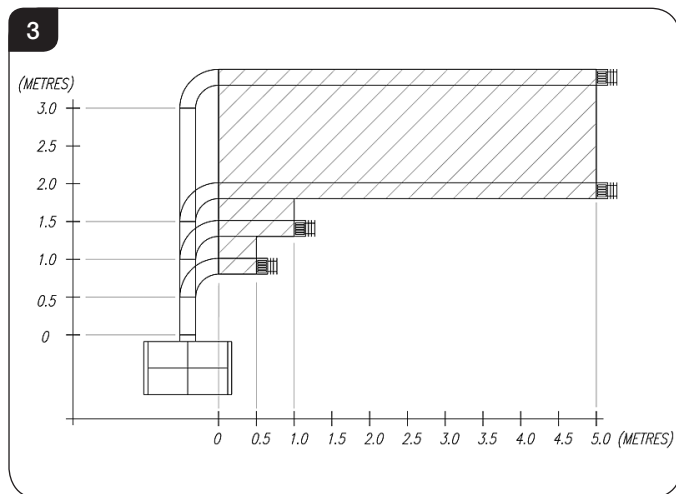

Start of bend to centre line of horizontal flue 170mm.
Centre line of vertical flue to end of bend 220mm.

2A. Top Flue Up and Out Kit

RIVA 2 800 - Kit No. 8534

Vertical from the top of the appliance then horizontally out, see Diagram 2. The basic kit comprises:

- 1 x 200mm vertical length
- 1 x 500mm terminal length (cut to length on site)
- 1 x 90° elbow
- 1 x wall plate
- 1 x 75mm restrictor
- 1 x 70mm restrictor - Not used on this appliance
- 1 x 60mm restrictor - Not used on this appliance

RIVA2 1050 - Kit No. 8523

Vertical from the top of the appliance then horizontally out, see Diagram 3. The basic kit comprises:

- 1 x 500mm vertical length
- 1 x 500mm terminal length (cut to length on site)
- 1 x 90° elbow
- 1 x wall plate
- 1 x 75mm restrictor

The kit may be used on its own. (Note – RIVA2 800 with a 200mm rise only the 500mm terminal length can be used). Extra lengths may be added to the vertical and horizontal from the list below, see Section 2.5.

2B. Top Flue Up and Out with Additional Bend

Any additional bend may be used on the horizontal section (either 45° or 90°), but the overall horizontal flue run will be reduced, see Diagram 4.

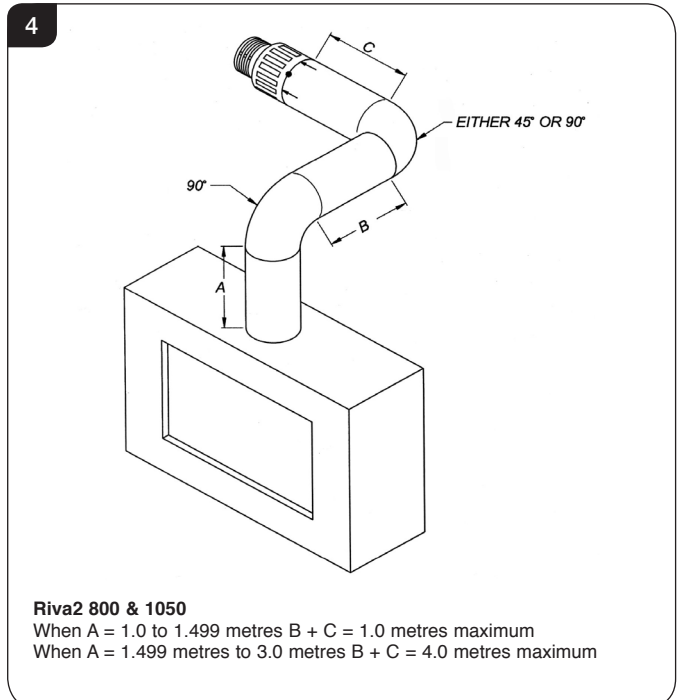

Riva2 800 & 1050

When A = 1.0 to 1.499 metres B + C = 1.0 metres maximum
When A = 1.499 metres to 3.0 metres B + C = 4.0 metres maximum

2C Top Flue Vertical Kit (8524/8524AN))

Vertical from the top of the appliance, see Diagram 5. A minimum vertical rise 3m (9'10") to a maximum 10m (32'10"). The basic kit comprises:

- 2 x 1m lengths
 - 1 x 1m terminal length
 - 1 x 52mm restrictor
 - 1 x 47mm restrictor - Not used on this appliance
 - 1 x 60mm restrictor
 - 1 x 70mm restrictor - Not used on this appliance
- Extra lengths may be added from the list below.

Installation Instructions

Site Requirements

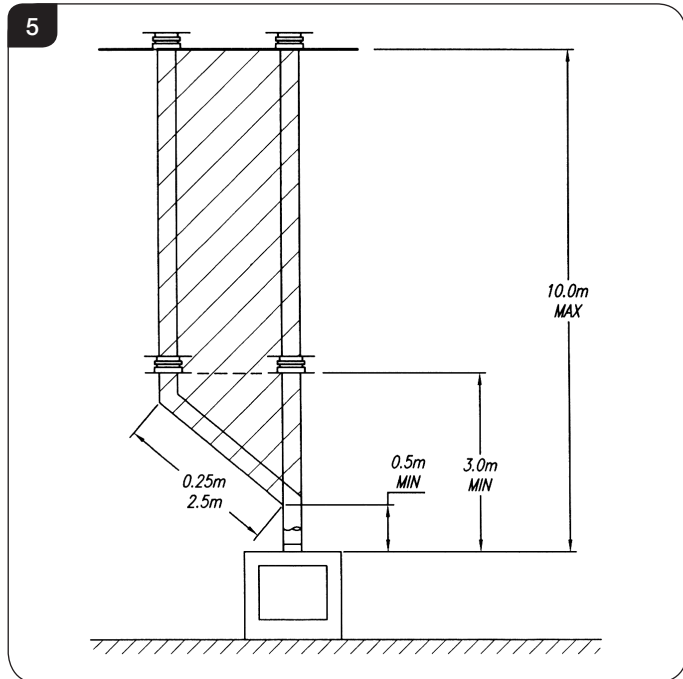

2D Top Flue Vertical Offset Kit (8530/8530AN)

Used with kit 8524. A minimum rise of 500mm (19 1/2") is required to the first bend, see Diagram 5.

3. Optional Extra Flue Lengths

All flue components are 150mm diameter (6").

| NOMINAL LENGTH | ACTUAL LENGTH | STAINLESS FINISH | ANTHRACITE FINISH |
|----------------|---------------|------------------|-------------------|
| 200mm | 140mm | 8527 | 8527AN |
| 500mm | 440mm | 8528 | 8528AN |
| 1000mm | 940mm | 8529 | 8529AN |
| 40° Bend | N/A | 8507 | 8507AN |
| 90° Bend | N/A | 8508 | 8508AN |

NOTE: Carefully consider:

- a) Terminal positions
- b) Flue supports
- c) Weatherproofing
- d) Fire precautions

For all the above options, you must conform to local and national codes of practice.

4. Chimney Renovation Kit (999-668)

Details of the Chimney Renovation Kit are available in the separate Installation Instructions - PR1181 Chimney Renovation Kit Instructions.

5. Gas Supply

THIS APPLIANCE IS INTENDED FOR USE ON A GAS INSTALLATION WITH A GOVERNED METER.

- 5.1 Before installation, ensure that the local distribution conditions (identification of the type of gas and pressure) and the adjustment of the appliance are compatible.
- 5.2 Ensure the gas supply delivers the required amount of gas and is in accordance with the rules in force.
- 5.3 You can use soft copper tubing on the installation and soft soldered joints outside the appliance and below the firebed.
- 5.4 A factory fitted isolation device is part of the inlet connection; no further isolation device is required.
- 5.5 All supply gas pipes must be purged of any debris that may have entered prior to connection to the appliance.
- 5.6 The gas supply enters through the aperture located on the RIGHT-HAND side of the box.

6. Ventilation

- 6.1 This appliance requires no additional ventilation.

7. Appliance Location

RIVA 2 BALANCED FLUE INSTALLATION FOR STUDWORK/FALSE CHIMNEY BREAST.

- 7.1 While the figures quoted in these instructions for clearances to combustible materials etc conform to the relevant standards; it is advisable to read the following notes.
- 7.2 Due to the high efficiency and high temperatures expected from a Glass Fronted Appliance it is advisable to plan carefully the exact method of installation. It is generally considered that the temperatures are higher on a balanced flue version due to the extra efficiency.
- 7.3 The studwork can be formed using metal or wood framework paying particular attention to the diagram showing combustible material distances. The carcass must consist in part of totally fire proof materials such as Supalux, Masterboard or Monolux. The fireproof board names as shown above are factory names and so there will be others available. (Contact your local building supplier).

Installation Instructions

Site Requirements

- 7.4 It is strongly recommended that a single sheet of this material also surrounds the fascia of the appliance to the sides and to the top to provide maximum heat proofing. Plasterboard can be used on the outer limits of your false chimney breast/studwork and then it should be possible to PVA the construction using a neat solution and a plaster finish.
- 7.5 There are also Plaster products on the market which can be used in areas of higher temperatures that have successfully been used in some installations (Vitcas and Envirograf are two examples). It may be prudent to contact the suppliers or manufacturers of these products to check your particular application or requirements.
- 7.6 Please remember that the expansion and contraction properties will be different between fireproof boarding and plasterboard and so a joint, or introduction of the two materials too close to the appliance may result in plaster cracking.
- 7.7 To avoid an unnecessary build up of heat in the void created, fit 2 vents at high level. The high level vents could be fitted at such a height that following engineers on a service could in fact inspect any flue work in the void. The enclosure must also be constructed to leave a gap between the top of the wall and the ceiling.

- 7.10 A combustible shelf must be:
 • maximum 150mm in depth
 • minimum, 150mm high above the fire
 A combustible side wall must be a minimum of 150mm from the appliance.
- 7.11 This appliance must stand on a non-combustible platform that is at least 12mm thick.
- 7.12 Although a hearth is not required, consideration for the young, elderly and infirm should be given. This is to prevent accidental touching of the glass as it reaches high temperature.



IMPORTANT : NEVER position an LCD/Plasma TV above this appliance.

- 7.8 Please note this appliance has been primarily designed for studwork applications. However, there are circumstances where the appliance could be installed in a block or brickwork fireplace using different methods and materials for the final effect. This void must be vented.
- 7.9 This appliance is not suitable for installation onto a combustible wall. Remove all combustible material from the area shown, see Diagram 6.

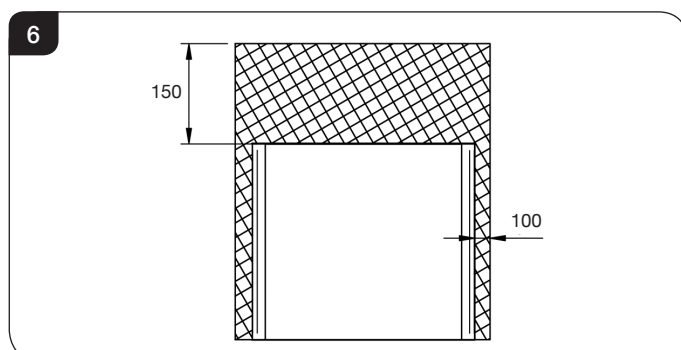

NOTE: If you intend to construct the fascia of the fireplace opening from natural materials it is recommended you cut this into three or more sections to prevent cracking. Resin-based materials may not be suitable. This appliance is an effective heat producer and attention must be paid to the construction and finish of the fireplace.

Installation Instructions

1. Safety Precautions



IMPORTANT NOTE: DUE TO THE DESIGN OF THE APPLIANCE NO CONVECTED AIR IS EMITTED FROM THE FRONT. WHEN INSTALLED IN THE FALSE CHIMNEY BREAST ALL THE HOT AIR IN THE VOID IS RETURNED INTO THE ROOM THROUGH EITHER THE TWO VENTS OR THE GAP LEFT AT THE TOP OF THE WALL.

- 1.1 For your own and other's safety, you must install this stove according to local and national codes of practice. Failure to install the stove correctly could lead to prosecution. **Read these instructions before installing and using this appliance.**
- 1.2 These instructions must be left intact with the user.
- 1.3 Do not attempt to burn rubbish on this appliance.
- 1.4 Keep all plastic bags away from young children.
- 1.5 Do not place any object on or near to the appliance and allow adequate clearance above the appliance.

IF THE APPLIANCE IS EXTINGUISHED OR GOES OUT IN USE, WAIT 3 MINUTES BEFORE ATTEMPTING TO RELIGHT THE APPLIANCE.



IMPORTANT: REFER TO DATA BADGE AND TECHNICAL SPECIFICATION AT THE FRONT OF THE MANUAL TO ENSURE THE APPLIANCE IS CORRECTLY ADJUSTED FOR THE GAS TYPE AND CATEGORY APPLICABLE IN THE COUNTRY OF USE.

FOR DETAILS OF CHANGING BETWEEN GAS TYPES REFER TO SERVICING, SECTION 15, REPLACING PARTS.

Unpacking

- 1.6 Remove the appliance from its packaging, and check that it is complete and undamaged.

Put the loose ceramic parts to one side so that they are not damaged during installation.

2. Installation Methods

THE APPLIANCE CAN BE INSTALLED INTO A FALSE CHIMNEY BREAST. THIS IS CONSTRUCTED OF WOOD OR METAL STUDWORK WITH A PLASTERBOARD AND SKIMMED FINISH. A BRICK AND BLOCK CONSTRUCTION WITH PLASTERBOARD AND SKIMMED FINISHED CAN ALSO BE USED.

THE FINAL APPEARANCE OF THE INSTALLATION FALLS INTO ONE OF THE FOLLOWING CATEGORIES:

- 1) A PLASTERED AND PAINTED WALL
- 2) A STONE FIREPLACE
- 3) A TILED OR MARBLE FINISH

THE APPLIANCE HAS A PURPOSE BUILT FRAME TO ENSURE THE WALL FINISH IS ALWAYS IN THE CORRECT POSITION.

FOR INSTALLATIONS 1 AND 2 THE WALL FINISH SITS AGAINST THE FLANGES ON THE SIDES AND THE VERTICAL FACES TOP AND BOTTOM OF THE BLACK FRAME, SEE DIAGRAM 1.

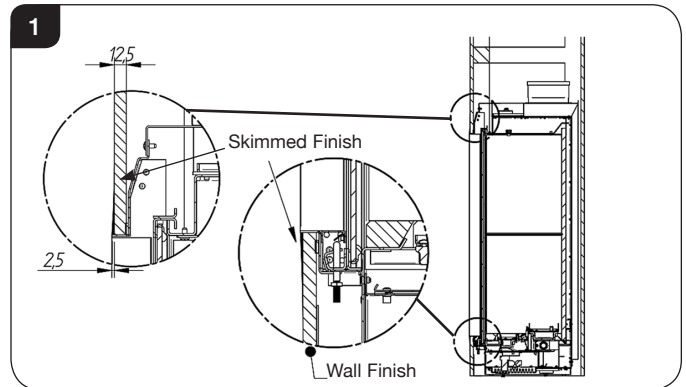

IF IT IS INTENDED TO FIT THIS APPLIANCE WITH A GAZCO STONE FIREPLACE, MANTEL OR HEARTH & SLIP SET, IT WILL BE NECESSARY TO REFER TO THE INSTRUCTIONS SUPPLIED WITH THE SURROUND OR MANTEL TO ENSURE THE RIVA2 IS INSTALLED AT THE CORRECT HEIGHT, SEE DIAGRAM 1A.

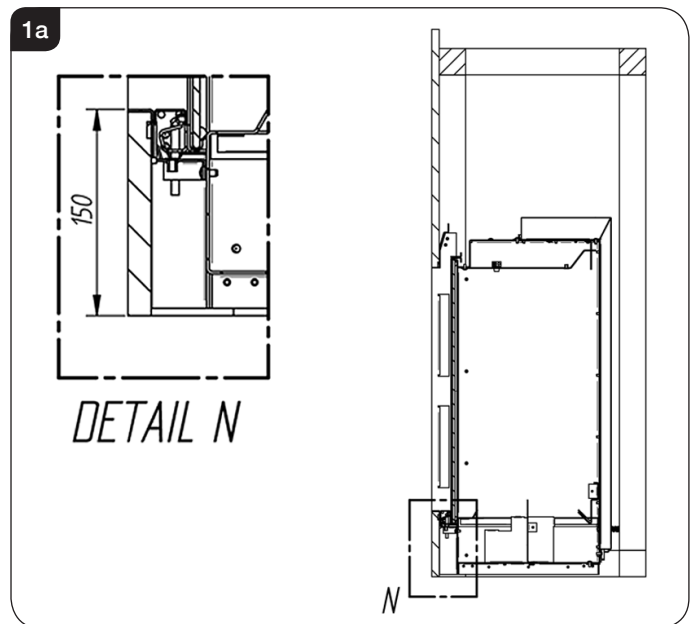

FOR INSTALLATION 3 IF THE TILE OR MARBLE IS TO FINISH FLUSH WITH THE BLACK FRAME THEN THE WALL FINISH WILL HAVE TO BE A SET DISTANCE BEHIND THE FRAME DEPENDING ON THE TILE/MARBLE THICKNESS, SEE DIAGRAM 2.

Installation Instructions

A FIXING KIT IS AVAILABLE FOR THIS INSTALLATION:
800 KIT NO: 999-440
1050 KIT NO: 999-321

ATTACH THE UPPER BAR BY SCREWING THROUGH THE TOP OF THE BLACK FRAME USING THE SCREW PROVIDED. THIS FORMS A VERTICAL FACE TO SUPPORT THE TILE/MARBLE FINISH, DIAGRAM 2. THE LOWER BAR IS ATTACHED UNDER THE BOTTOM OF THE BLACK FRAME. THE SCREWS ARE INSERTED DOWNWARDS BEHIND THE FRAME, DIAGRAM 2.

DUE TO THE EXPANSION OF METAL IT IS ADVISABLE NOT TO USE ADHESIVE BETWEEN THE TILE/MARBLE AND THE SUPPORT BARS. ONLY USE ADHESIVE BETWEEN THE TILE/MARBLE AND THE WALL FINISH.

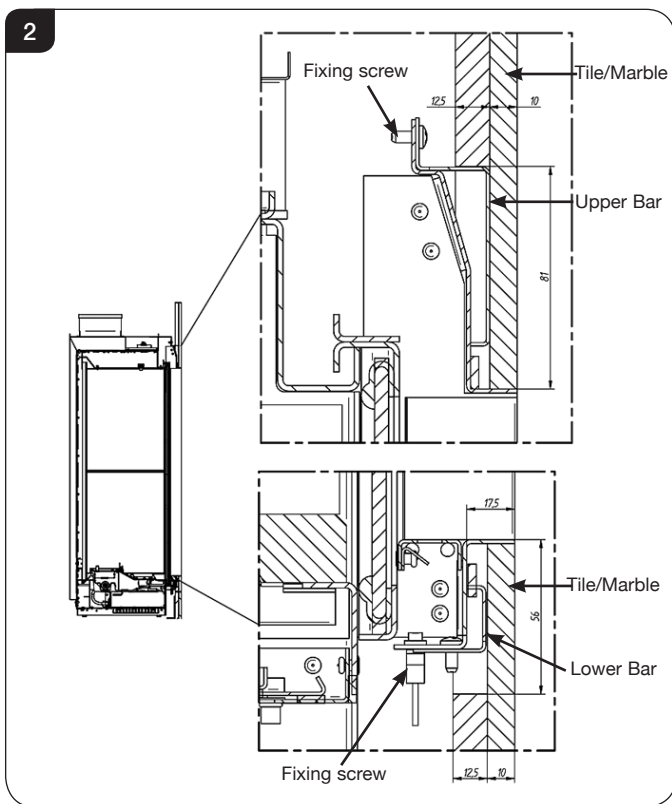

ALTERNATIVELY THE TILE/MARBLE CAN OVERHANG FORWARD OF THE BLACK FRAME BUT MUST NOT PROTRUDE INSIDE SO AS TO REDUCE THE SIZE OF THE DOOR FRAME APERTURE.

- 2.1 **DISTANCE TO COMBUSTIBLE MATERIAL**
COMBUSTIBLE PARTS OF THE STUDWORK MUST BE KEPT BEYOND THE MINIMUM DIMENSIONS SHOWN IN DIAGRAM 3. EVEN IF THE FRAMEWORK IS PROTECTED BY NON-COMBUSTIBLE MATERIAL, YOU MUST MAINTAIN THESE DIMENSIONS, SEE DIAGRAM 3.

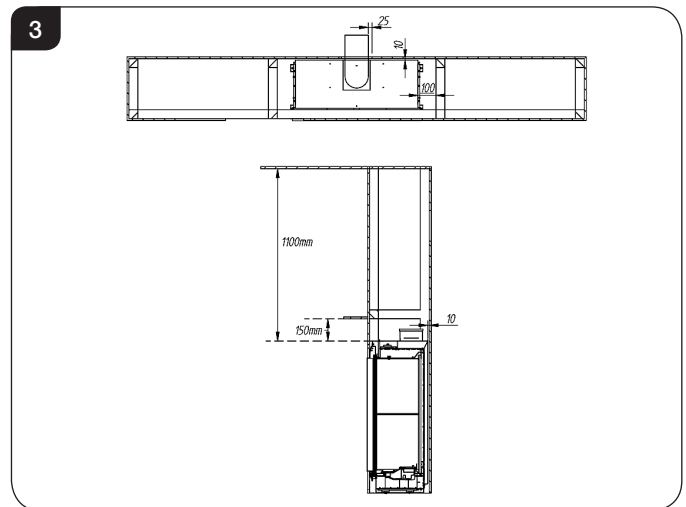

- 2.2 **DO NOT PACK THE VOID AROUND OR ABOVE THE APPLIANCE WITH INSULATION MATERIALS SUCH AS MINERAL WOOL.**
- 2.3 **THE VOID BUILT FOR THE CASSETTE MUST BE VENTILATED TO PREVENT A BUILD-UP OF HEAT. YOU MUST FIT 2 VENTS OF APPROXIMATELY 100CM² EACH. THESE VENTS RETURN WARM AIR BACK INTO THE ROOM, SEE DIAGRAM 4.**

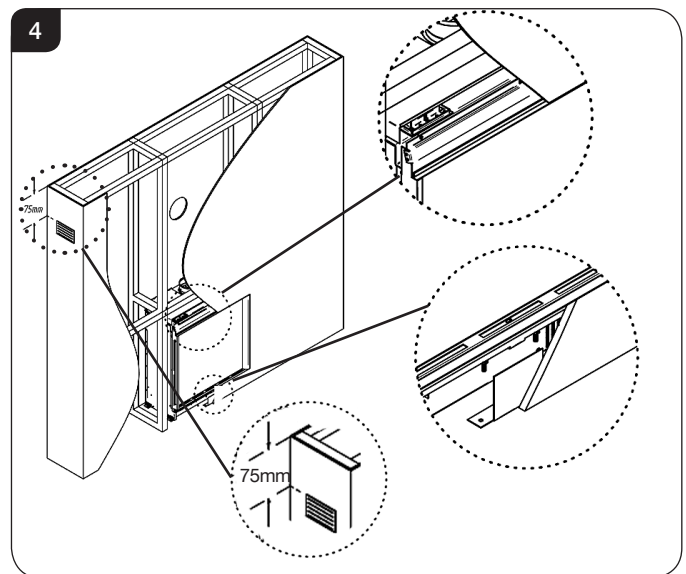

- 2.4 **ALTERNATIVELY THE ENCLOSURE CAN BE CONSTRUCTED TO LEAVE A GAP BETWEEN THE TOP OF THE WALL AND THE CEILING. ENSURE THE OPEN AREA IS EQUAL TO OR GREATER THAN THE TWO VENTS.**
- 2.5 **AN ACCESS HATCH MUST BE LEFT IN THE SIDE OF THE CHIMNEY BREAST FOR FUTURE SERVICING AND INSPECTION OF THE FLUE AND APPLIANCE.**

Installation Instructions

3. Installation Of The Appliance

- 3.1 Remove the appliance from the carton and discard all unnecessary packaging. Ensure no components are thrown away when unpacking.
- 3.2 If the appliance is being fitted with a **Gazco Chimney Renovation Kit**, the four supplied metal cover plates **MUST** be fitted to the appliance heat shield - see PR1181 Chimney Renovation Kit instructions, Section 4 Page 8.
- If the **Chimney Renovation Kit** is NOT being used then the cover plates can be discarded.
THE COVER PLATES MUST NOT BE FITTED TO THE APPLIANCE IF IT IS BEING INSTALLED WITH A STANDARD GAZCO FLUE OPTION AS LISTED IN THIS INSTALLATION MANUAL (Page 16 Section 2).
- 3.3 To remove the glass frame:
Remove the side trims, see Diagram 5.

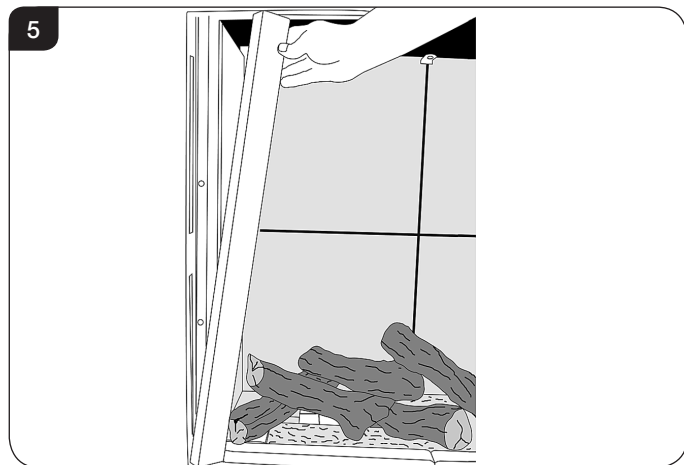

These are held on by magnets.

- 3.4 Lift out the bottom slotted trim, see Diagram 6.

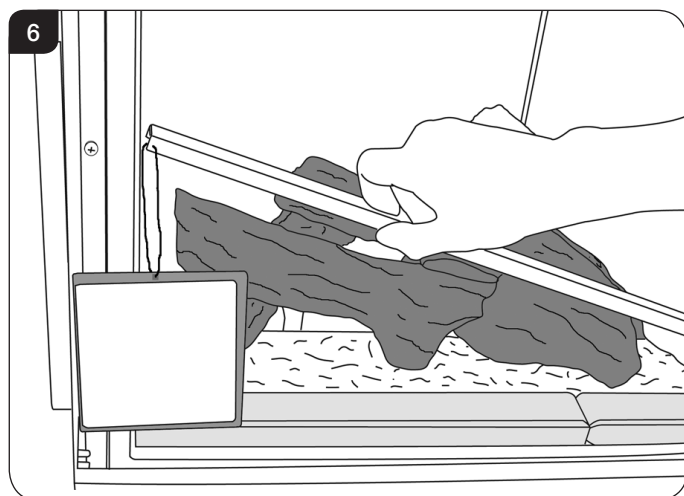

- 3.5 Remove all the screws around the glass frame. (10 on the 800 model and 9 on the 1050 model)
Please note: The screws are located down both sides and along the bottom edge of the glass frame.

- 3.6 Lift the frame using the handle, up and over the lower edge. Take extreme care not to damage the paint, see Diagram 7.

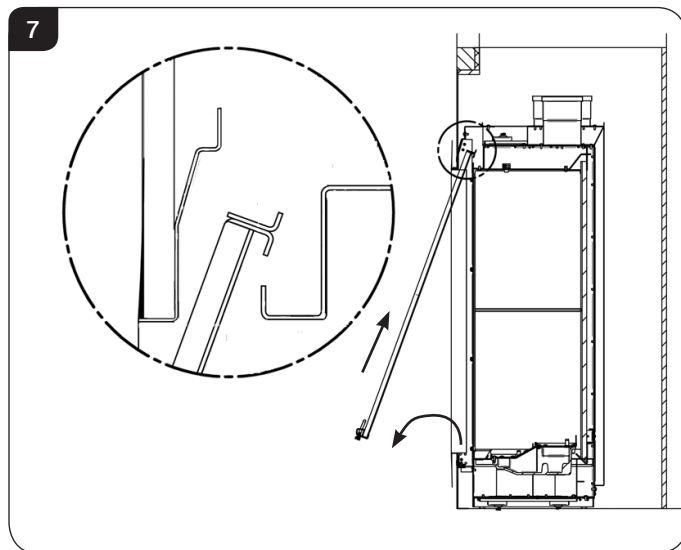

- 3.7 Lower the frame - the top edge will be hooked onto the top of the appliance.
- 3.8 Hold the sides of the frame and lift approximately 25mm and pull the top forward. This will release the frame- Lower to clear the appliance.
- 3.9 Remove the box from the appliance and store safely as it contains the remote control and fuel effects, etc.
- 3.10 Remove all the vermiculite liners. The rear panels can remain in place. See Replacing Parts, Section 4.
- 3.11 Remove the Burner Assembly, see Replacing Parts, Section 5.
- 3.12 The gas supply enters the fire through the **RIGHT HAND** side of the appliance along with the battery and touch pad leads, see Diagram 8.

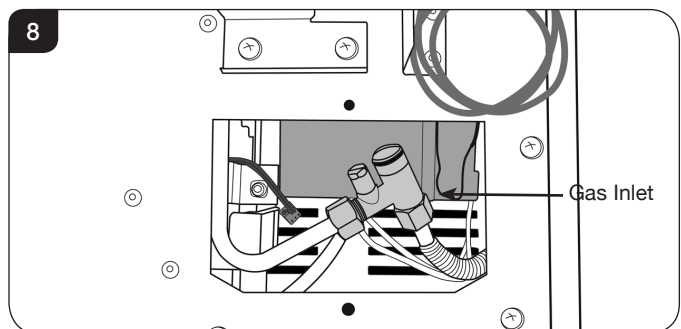

Riva 2 gas inlet pipe

The Riva 2 is supplied with a flexible pipe extension to aid installation from the appliance inlet to the rigid gas supply pipe.

- 3.13. To fit the Gas Inlet extension:
Gain access to the isolating elbow.
- 3.14 Remove the isolating elbow from the inlet pipe.

Installation Instructions

3.15 Bend the flexible pipe as shown, see Diagram 9.

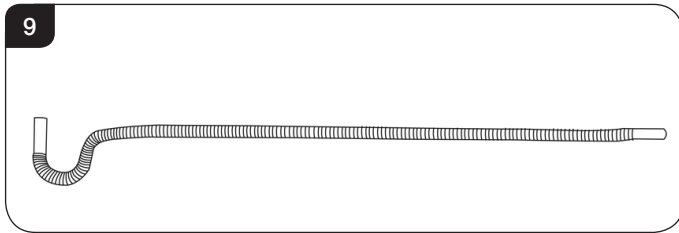

3.16 Fix the isolating elbow on the flexible pipe and secure using an 8mm Pipe Nut.

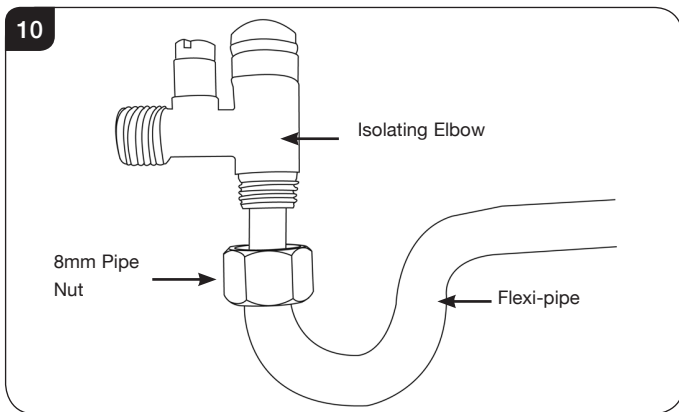

3.17. Thread the flexible pipe through the top of the control cover and out of the access hole in the side of the appliance. Attach the isolating elbow back onto the inlet pipe, See page 21 for details on the Isolating Elbow.

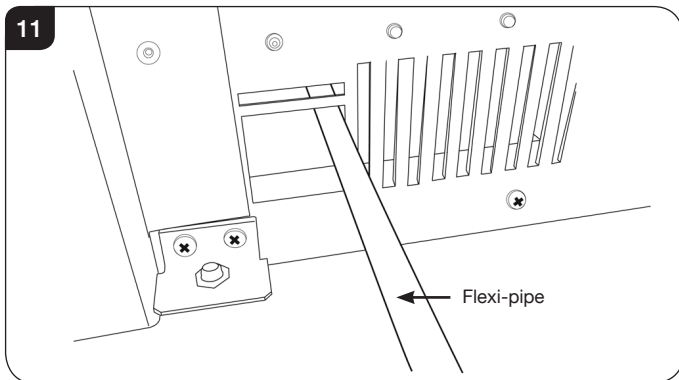

3.18 The 8mm compression fitting can now be attached to the flexible pipe. The pipe may be bent to suit the fitters pipework.

4. Studwork Installation for Riva 2

NOTE: IF THE APPLIANCE IS TO BE RAISED OFF THE FLOOR ENSURE THE PLATFORM IS SUITABLY SUPPORTED. THESE APPLIANCES ARE VERY HEAVY.

- 4.1 Build the studwork chimney breast and enclosures to the desired size to include the protected platform at the required height.
- 4.2 Line the aperture for the appliance with 12mm thick non-combustible material as shown, see Diagrams 12 and 13.

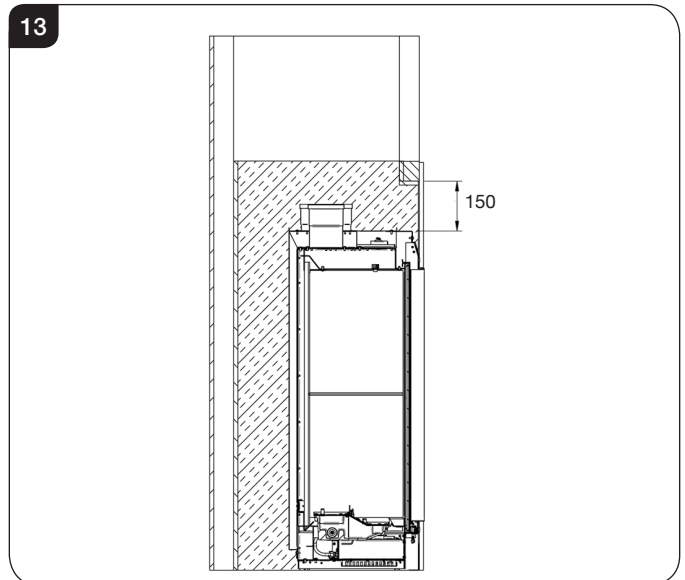
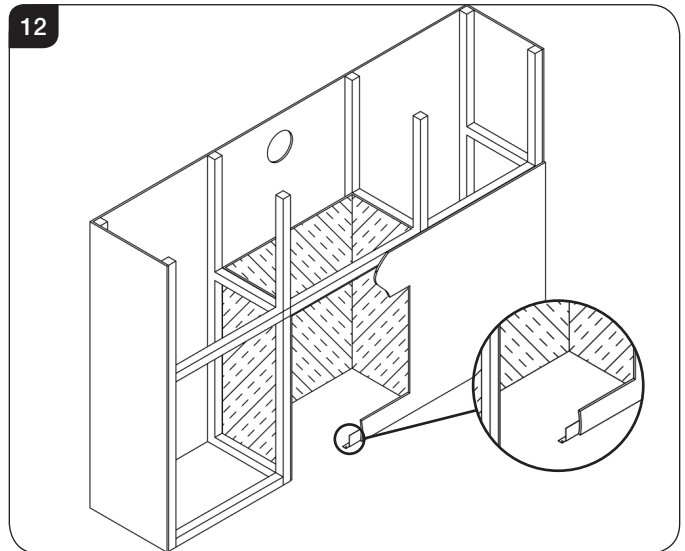

- 4.3 Do Not fit a timber bottom on the floor in front of the appliance as this will block the airflow. Use the metal bracket provided, see Diagram 12.
- 4.4 Ensure the clearances are maintained, see Diagram 14.
- 4.5 Site the appliance and decide on flue requirements.
- 4.6 Cut a hole for the flue exit - see **Installation Instructions, Flue Assembly**.
- 4.7 Provide gas into the cassette void on the right-hand side.

NOTE: The touch pad and battery lead are long enough to allow the touch pad and battery box to be sited on the left hand side of the appliance.

- 4.8 Fit non-combustible board to the studwork around the fire. This should extend a minimum of 150mm above the appliance and at least 100mm to the sides of the appliance, see Diagram 14. It is however recommended that this is extended further to prevent cracking.

Installation Instructions

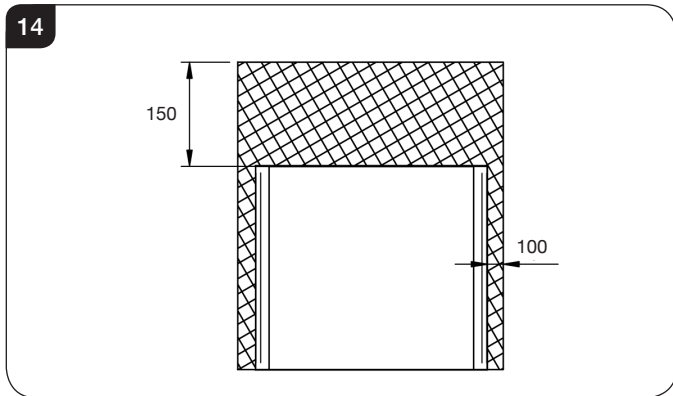

4.9 Apply plasterboard to the remainder of the studwork.

Apply a plaster finish to the front of the chimney breast.

4.10 To finish this installation connect the wall box and batteries following instruction in Section 5 below.

Connect:

- the flue system (see **Installation, Flue Assembly**)
- and gas services (see **Installation 2.3**) using the opening in the side of the chimney breast for access.

After commissioning finish the sides of the chimney breast, see Diagram 15.

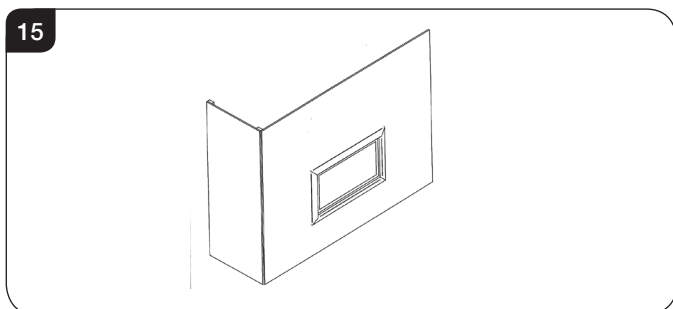

5. Wall Box & Battery Installation



Please note: As an optional extra Gazco can provide a mains adapter to supply constant power to the appliance control box instead of the battery pack.

If installing an appliance with the adapter make provision for a mains power socket within 1.5m of the control box and follow the instructions provided.

When installing the wall box allow at least 100mm of slack wire in the touch pad lead and battery lead where they enter the appliance on the right hand side. This allows the removal of the control assembly during servicing.

5.1 Decide on the position for the wall box containing the batteries and wall switch and cut the necessary hole. Connect the wire from the fire to the battery pack, see Diagram 16.

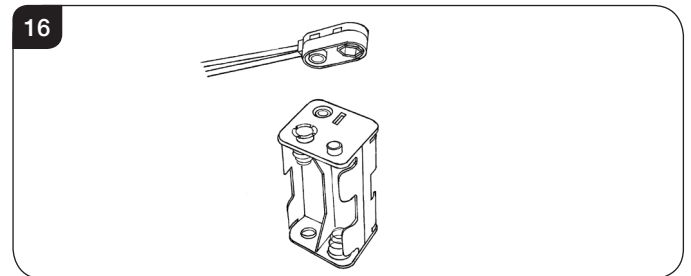

5.2 Connect the wire from the fire to the touch pad/connector, see Diagram 17.

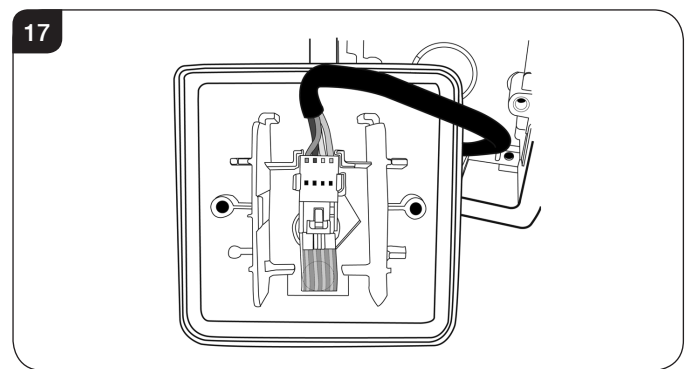

5.3 Correctly position the four new AA size batteries and re-assemble the battery holder as shown, see Diagram 18.

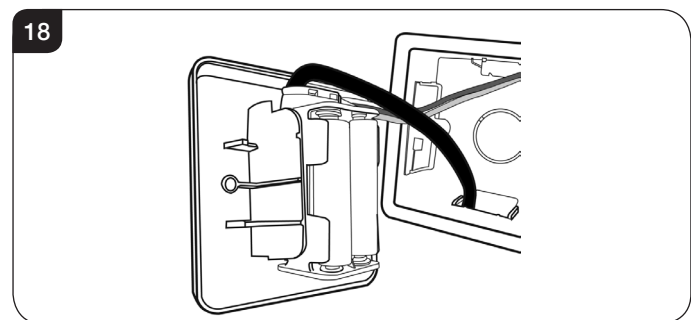

5.4 Secure the wall switch plate to the wall box using the two fixing screws, see Diagram 19.

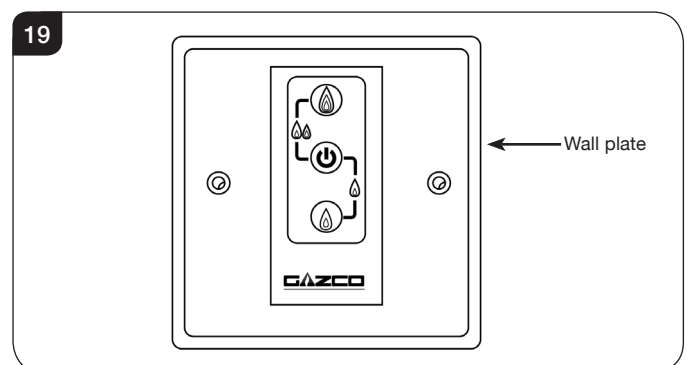

Installation Instructions



IMPORTANT

The wall switch must be installed using a non-metallic mounting box, please ensure that the plastic dry lining box is used wherever possible. If it is intended to install the wall switch on a masonry it is possible to drill through the rear of this box and secure in position using wall plugs and screws although a small amount of finishing work will be required to cover the plastic side securing tags. Alternatively a standard 47mm deep pattress box can be used to surface mount the wall switch.

6. Flue Assembly

6.1 See Site Requirements, Section 2, Flue Options.

TAKE CARE WHEN MARKING OUT FOR THE FLUE AS IT IS DIFFICULT TO MOVE AFTER INSTALLATION. IF A RESTRICTOR IS REQUIRED FIT THIS BETWEEN THE SMALL OUTLET SPIGOT AND THE AIR DUCT SEE DIAGRAM 20. REFER TO TECHNICAL SPECIFICATIONS FOR RESTRICTOR SIZE.

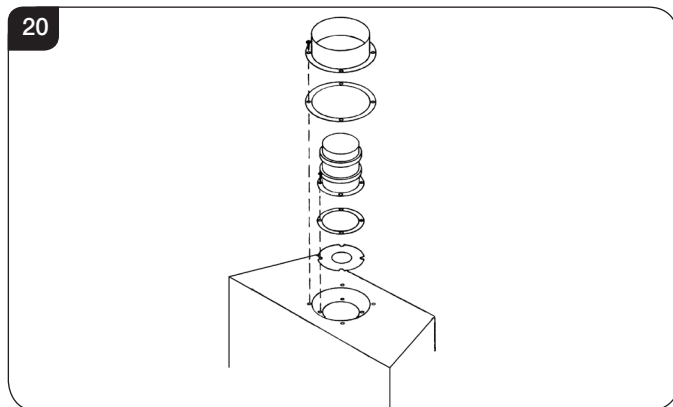

6.2 A 152mm (6") diameter hole in the wall is required to install the flue. This can be achieved by either:

- a) Core drill
- b) Hammer and chisel

6.3 Drill small holes around the circumference when using method b) Make good both ends of the hole.

6.4 Allow enough room either above or to the side of the appliance to assemble the flue on top.

6.5 Assemble a horizontal flue in the following order:

- Vertical section
- 90° elbow
- Horizontal plus terminal

6.6 Support the opening of a masonry installation with a lintel.

6.7 Only the horizontal terminal section can be reduced in size.

To find the length:

6.8 Measure from the outside of the wall to the stop on the 90° elbow.

6.9 Add 10mm to the outlet end.

6.10 Measure from the edge of the slots closest to the wall.

6.11 Mark around the flue, see Diagram 21.

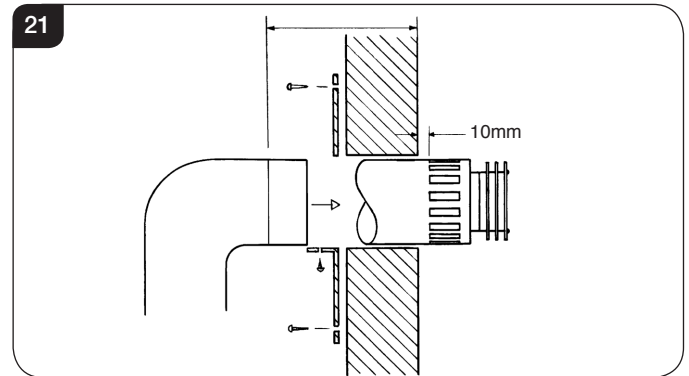

A wall plate is supplied to fix the flue to the wall:

6.12 Bend the tab to 90°.

6.13 Assemble the plate onto the flue but wait to secure to wall and flue after the flue is fully assembled.

6.14 The cardboard fitment in the terminal is used to support the flue whilst it is cut to length. **ONCE CUT TO SIZE, REMOVE THE CARDBOARD REMNANT**, see Diagram 22.

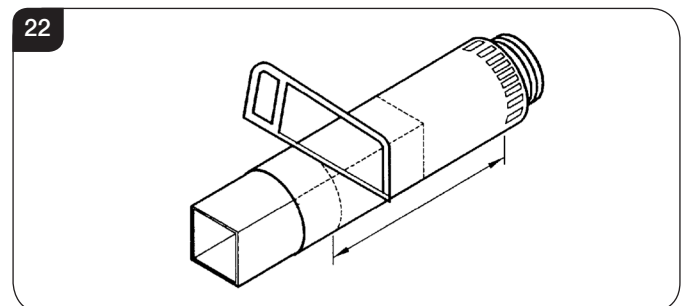

TOP EXIT - VERTICAL FLUE

If a vertical only flue system has been purchased refer to Site Requirements, see Diagram 5.

The following areas need careful consideration:

- a) Terminal Positions
- b) Flue Supports
- c) Weatherproofing
- d) Fire Precautions

For all of the above, local and national codes of practice must be adhered to.

TABLE A - TOP EXIT - VERTICAL ONLY, INCLUDING OFFSET

| Vertical Height from Floor | Restrictor Size |
|----------------------------|-----------------|
| 3,000mm to 4,990mm | 60mm Ø |
| 5,000mm to 10,000mm | 52mm Ø |
| Flue temp | 400°C |

Installation Instructions

6.15 Connect a suitable pressure gauge to the test point located on the inlet fitting.

6.16 Replace the burner.

NOTE: On the Riva2 1050 the burner can be permanently fixed. The Riva2 800 burner has to be removed after the pressure check. This is to allow access to refit the controls cover plate.

6.17 Turn on the gas and light the appliance. Check for leaks.

6.18 Turn the appliance to maximum and check that the supply pressure is as stated on the data badge.

6.19 Turn off the gas and replace the test point screw.

6.20 Turn the gas back on and check the test point for leaks.

7. Assembling the appliance

7.1 VERMICULITE PANELS

NOTE: RIVA2 FRONT AND REAR PANELS ARE IN TWO PIECES.

The rear panels are already in place. Ensure the two-piece rear panels are centralised, with the chamfers touching and pushed together, see Diagram 23.

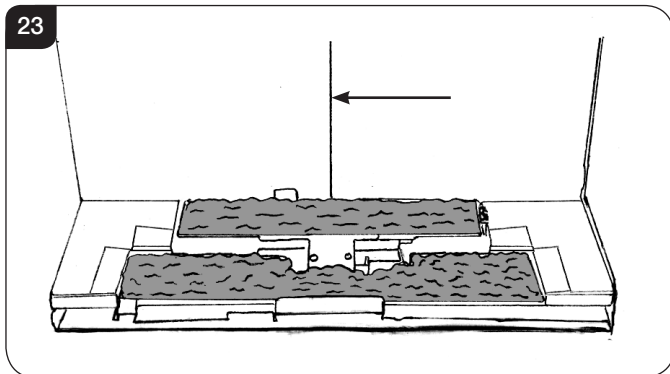

7.2 Place the left hand and right hand L shaped lower panels either side of the burner, see Diagram 24.

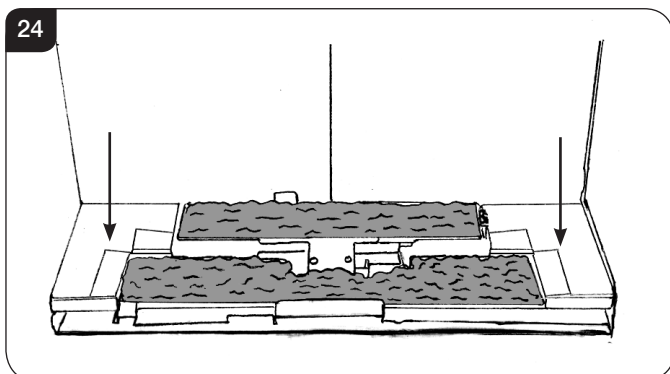

7.3 Place the left and right hand front strips on the front edge of the firebox. The rear of the vermiculite strips are angled to match the angled stops on the firebox. Centralise the strips and ensure all the chamfers align, see Diagram 25.

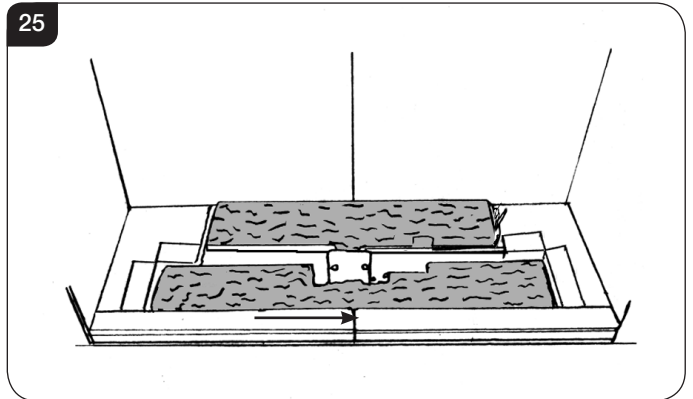

7.4 Place the side panels on top of the lower panels and secure with clips.

The side panels are left and right handed. Ensure they are fitted in the correct orientation and that the grooves align with the rear panels, see Diagram 26.

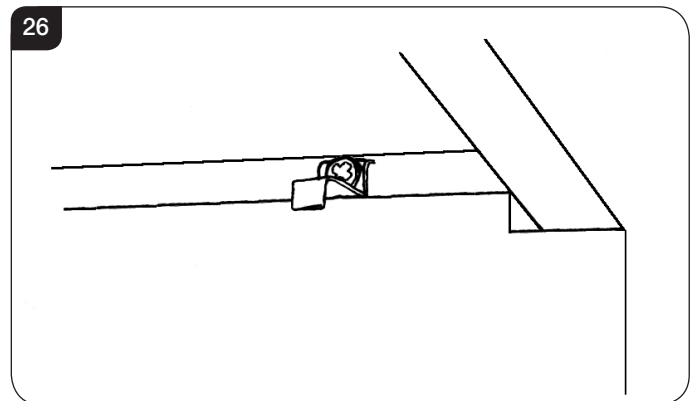

Installation Instructions

8. Arrangement of the fuel bed

Advice on handling and disposal of fire ceramics



The fuel effect of this appliance is made from Refractory Ceramic Fibre (RCF), a material which is commonly used for this application.

Protective clothing is not required when handling these articles, but we recommend you follow normal hygiene rules of not smoking, eating or drinking in the work area and always wash your hands before eating or drinking.

To ensure that the release of RCF fibres are kept to a minimum, during installation and servicing a HEPA filtered vacuum is recommended to remove any dust accumulated in and around the appliance before and after working on it. When servicing the appliance it is recommended that the replaced items are not broken up, but are sealed within heavy duty polythene bags and labelled as RCF waste.

RCF waste is classed as stable, non-reactive hazardous waste and may be disposed of at a licensed landfill site.

Excessive exposure to these materials may cause temporary irritation to eyes, skin and respiratory tract; wash hands thoroughly after handling the material.

9. Log Layout

LOGS MUST BE POSITIONED ACCORDING TO THE FOLLOWING INSTRUCTIONS TO GIVE THE CORRECT FLAME EFFECT.

- 9.1 Use all the vermiculite to fill the burner tray and spread evenly across the whole burner - The centre ramp does not have vermiculite on it. Spread evenly over the side and front panels (base). **Take care not to block the air gap around the burner.**

Cover burner area BEFORE doing the panel decoration ensuring it is well covered - Avoid getting Vermiculite dust on the burner.

The logs are identified with letters A - H on the underside or rear of the log. A, B, C, D and G have holes to locate the logs on the pins fixed to the burner skin, Diagram 9.

Logs E and F have interlocking recesses which locate with logs B and D. H has no locations but will rest in a specific position.

There are two bags of effect material. One consists of black embers, the other is a special pack of Embaglow. This looks like wire wool and is placed after the logs are arranged.

- 9.2 Locate Log A on the pin in front of the pilot. Ensure the left hand side of the log rest on the upper part of the burner, see Diagram 10.

27

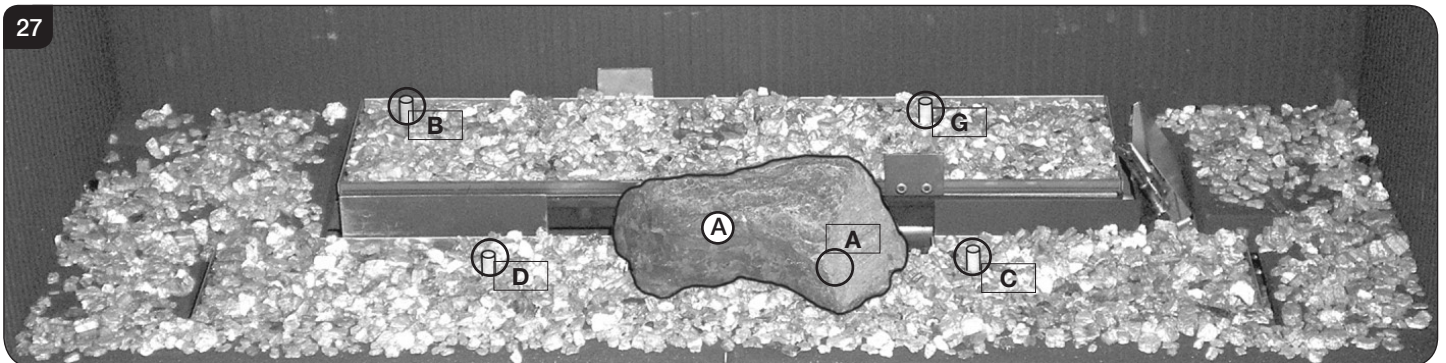

- 9.3 Locate Log B on the top left hand pin. The end of the log nearest the front of the appliance will rest on the side liner on the 800 model. On the 1050 model a distance of 25-30mm between the front left corner of the burner and the log is required, see Diagram 28.

28

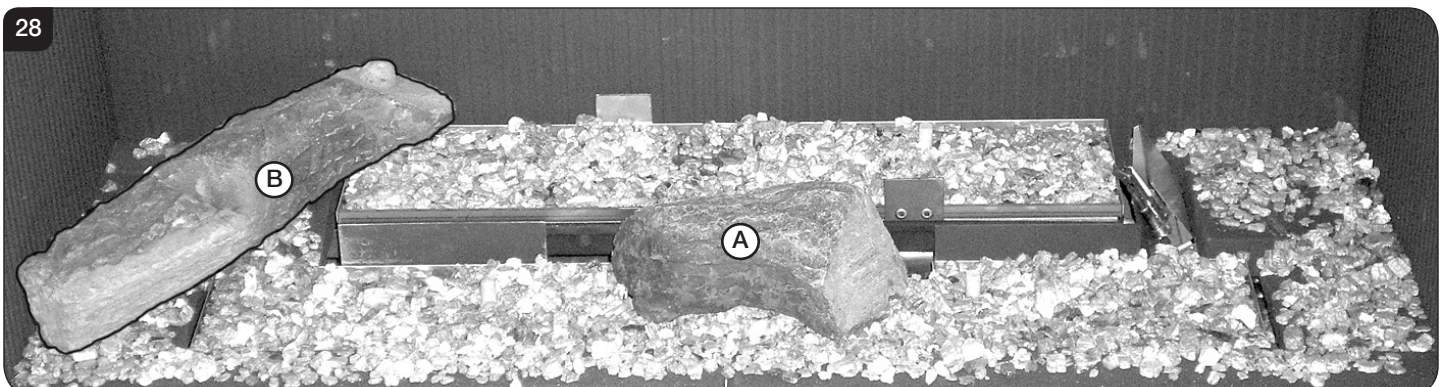

Installation Instructions

- 9.4 Locate Log C on the lower burner right hand pin. The rear of the log should touch the Pilot Shield at the end of the rear burner, see Diagram 29.

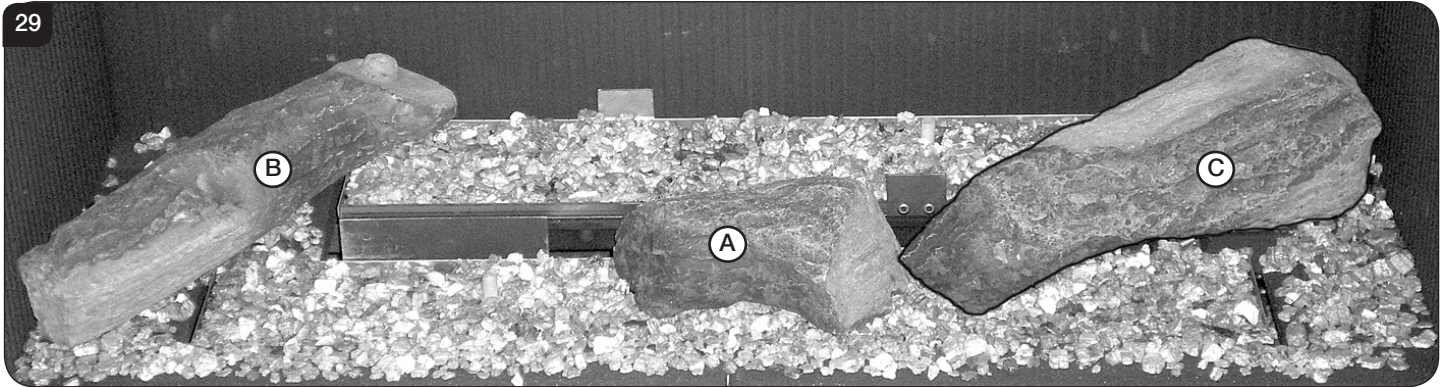

- 9.5 Locate Log D on the lower left hand pin. The hole is in the short branch of the log. The left hand side of the log sits in the groove on Log B, see Diagram 30.

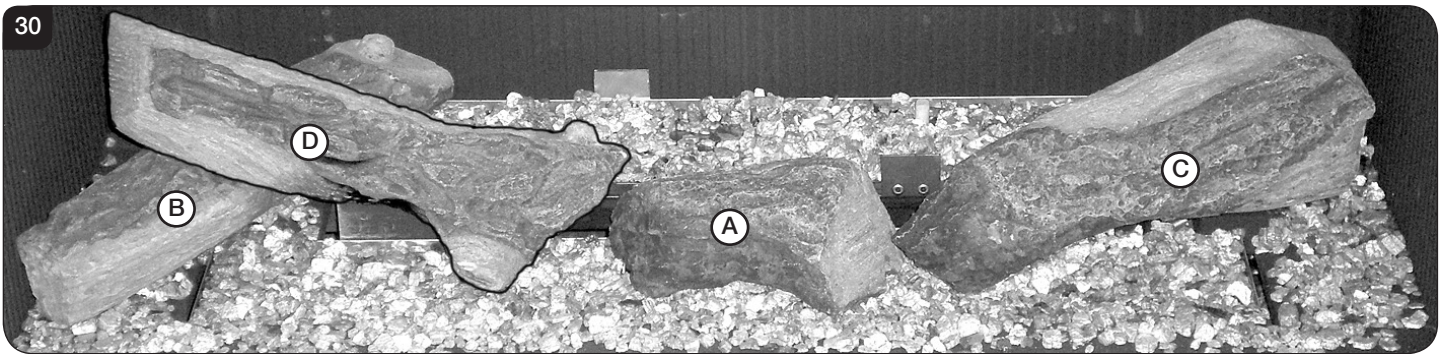

- 9.6 Place Log E on top of Log D. Engage the raised location into the recess on Log E. The rear of the log pushes against the right side of the raised tag on the rear of the burner, see Diagram 31.

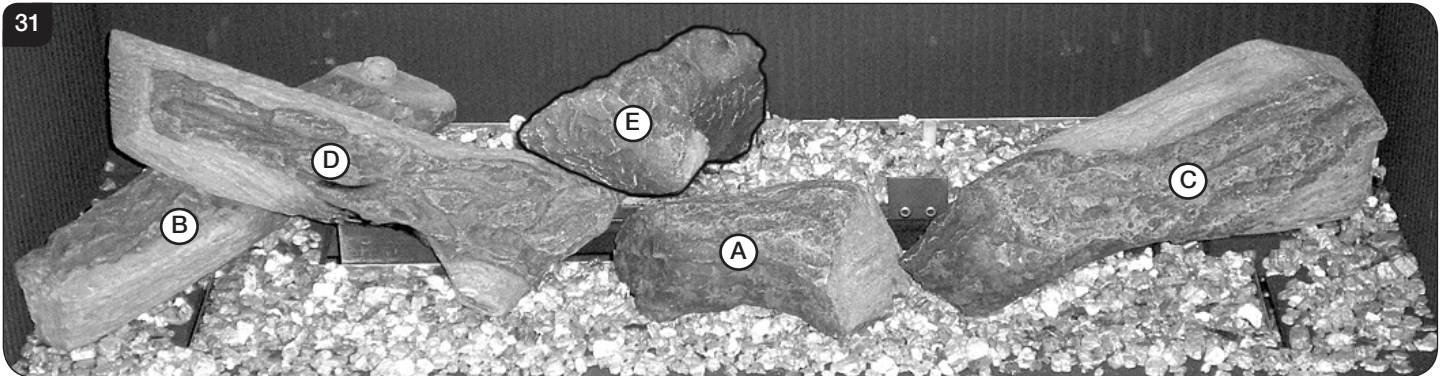

- 9.7 Place Log F on top of Log B and engage the raised locator into the recess on Log F. The right end of the log pushes against the raised tag on the rear of the burner, see Diagram 32.

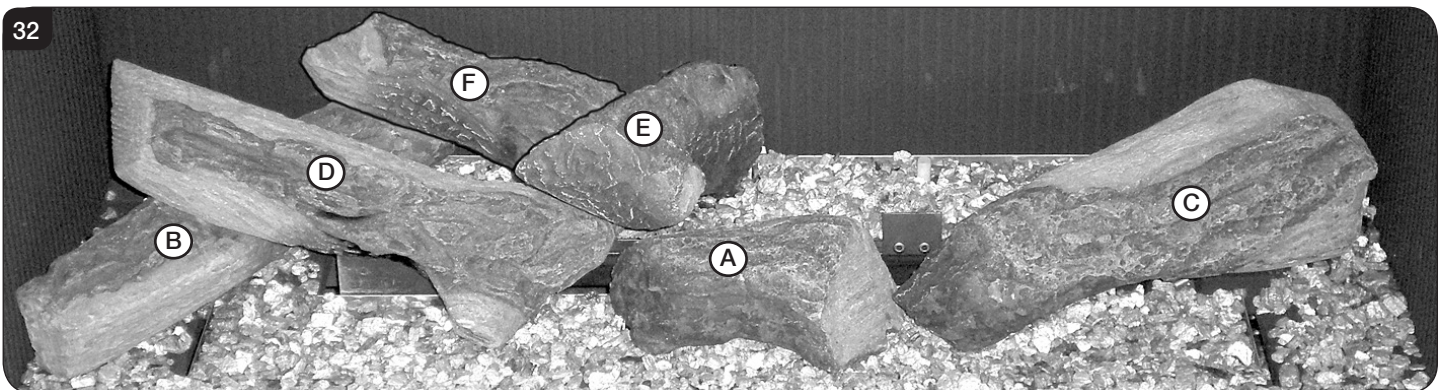

Installation Instructions

- 9.8 Place Log G on the remaining pin. The charred effect faces forward and the rear of the log rests against the Pilot Shield on the edge of the burner tray, see Diagram 33.

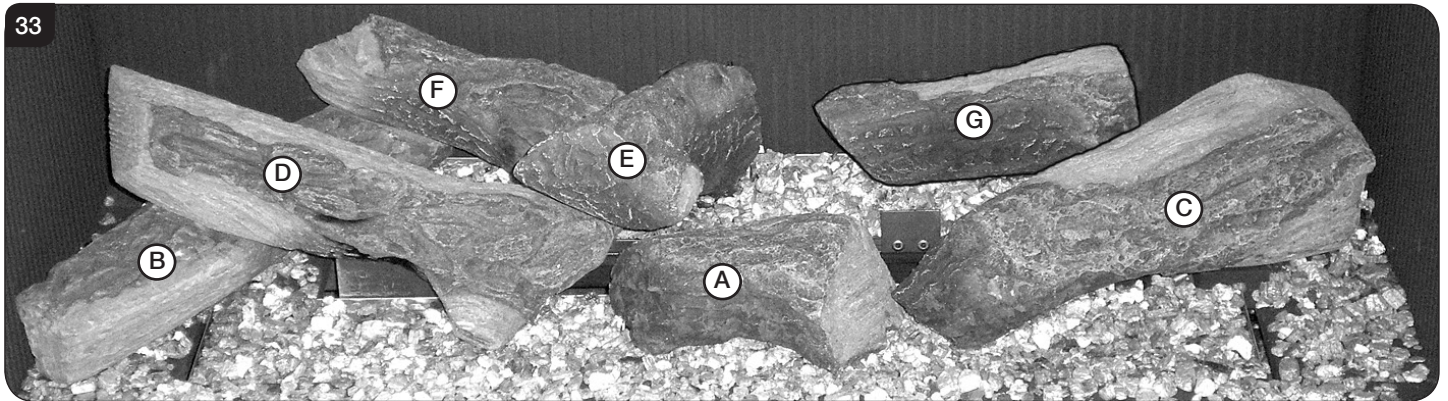

- 9.9 Log H locates on three points. The short branch locates in the recess on the Left Hand side of Log G. The main body of Log H rests on Log E and the front charred area of Log H rests between Log A and C on the raised tag, see Diagram 34.

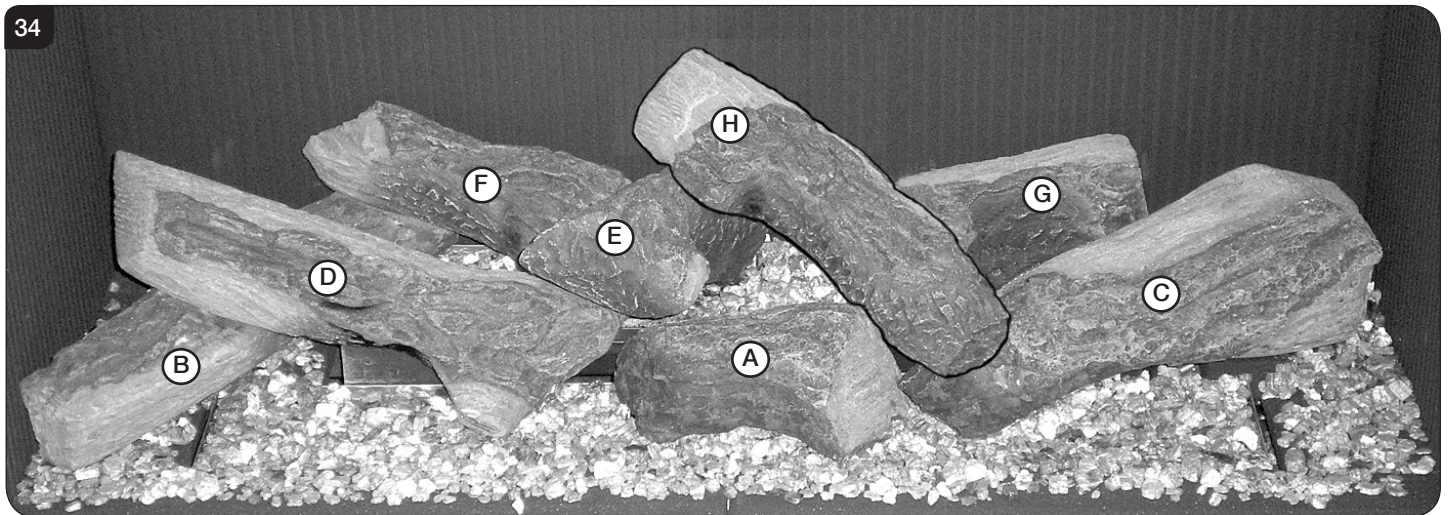

- 9.10 Place some of the black embers underneath the logs C and D on the front burner only. A few embers are placed between Logs D, A and C. Scatter a few embers in front of long logs B & C on the side panels. For best effect ensure no black embers are forward of the log front faces, see Diagram 35.
Take care not to block the air gap around the burner.

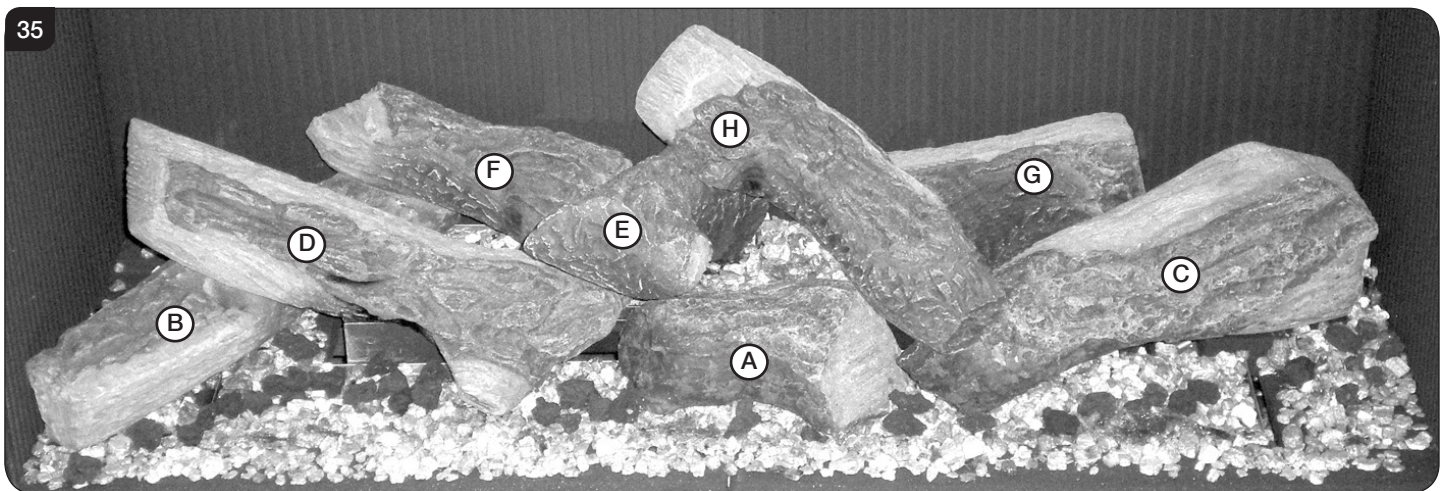

Installation Instructions

- 9.11 Lastly locate the Embaglow wire wool. Take care when positioning to ensure the best final effect.
NOTE: ONLY HALF THE MATERIAL SUPPLIED IS USED.

Separate half the material by hand and place the remainder back in the bag - the customer must keep this for use in the future. The material must be pulled into shape until only a very thin layer is applied onto the burner - too much material being used can diminish the flame effect.

The size of each piece is approximate. Loose strands of material can be trimmed with a pair of scissors. This will make it easier to apply.

There are six areas the Embaglow is placed in. Ensure it does not overhang the front of the burner, see Diagram 36 and 37.

36

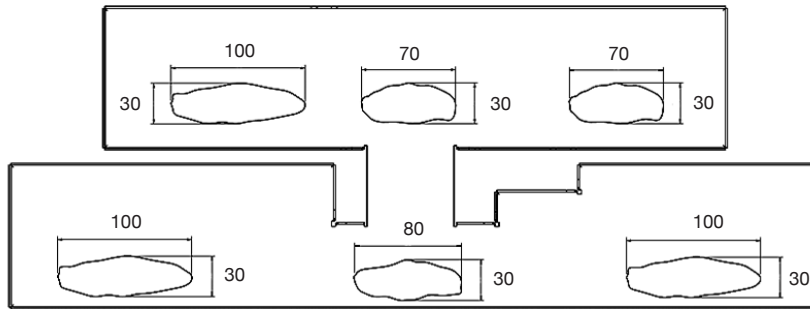

37

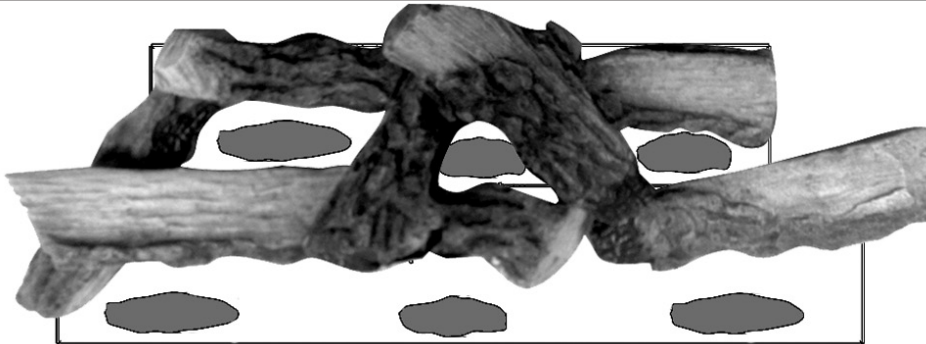

NOTE: This material will last approximately 500 hours burning. It is a consumable part and should be replaced when necessary. It can be purchased from your local dealer, Part No. GZ8471.

Installation Instructions

10. Completion of assembly

10.1 To fit the window frame:

NOTE: IT IS ADVISABLE TO PROTECT THE LOWER BLACK TRIM AS THIS IS EASILY SCRATCHED.

Insert the top of the window frame behind the black trim and hook the frame onto the vertical face of the firebox, see Diagram 38.

Carefully rest the bottom of the frame up against the appliance.

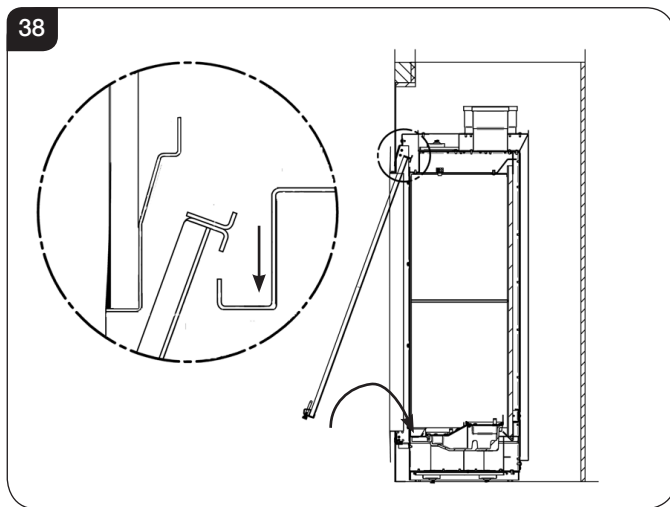

10.2 Using the handle in the bottom of the frame lift the frame over the bottom trim and locate onto the lower brackets. Keep pressure on the top of the frame to ensure it hooks back onto the firebox.

10.3 Replace ALL of the glass frame securing screws ensuring that a screw is present in all fixing slots (10 in the Riva2 800 and 9 on the Riva2 1050). Tighten each of the screws in the bottom of the frame first and work up the Left and Right hand sides tightening each of the screws in turn, see Diagrams 39a and 39b.

DO NOT OVERTIGHTEN THE SCREWS.

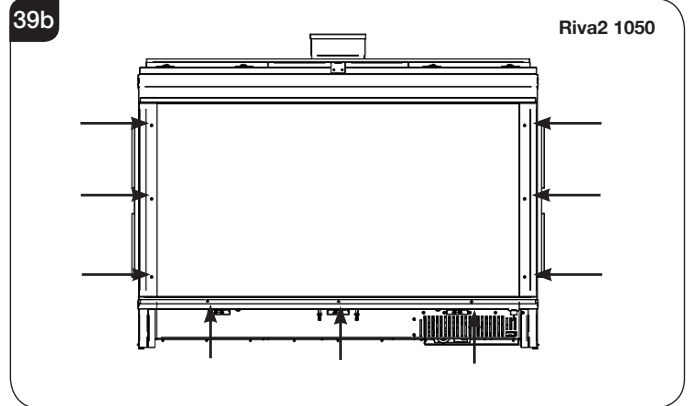
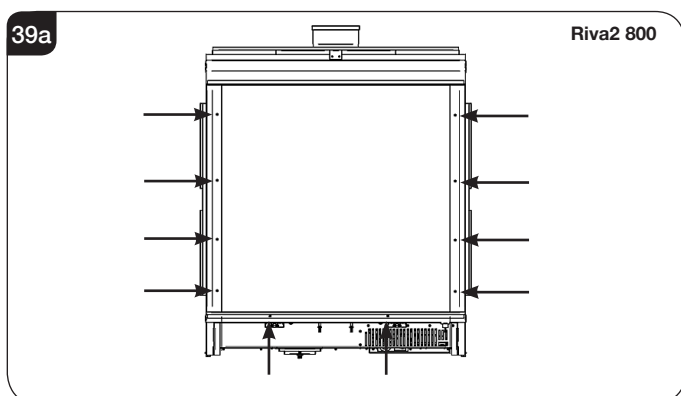

UNDER NO CIRCUMSTANCES SHOULD THE APPLIANCE BE USED IF ANY OF THE GLASS FRAME RETAINING SCREWS ARE LOOSE OR MISSING.

10.4 Place the slotted trim over the studs to cover the gap at the bottom of the window. The louvres point forwards, see Diagram 40.

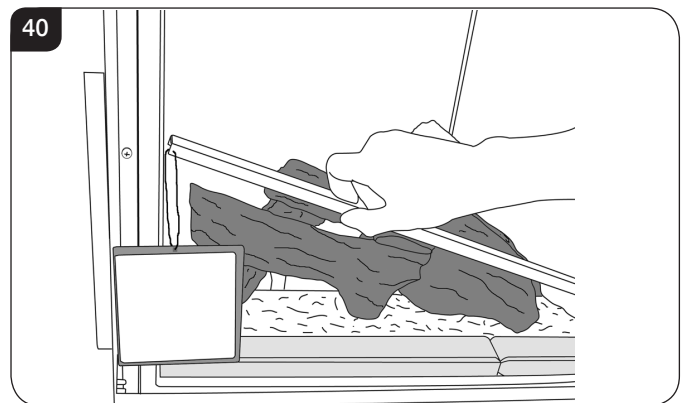

10.5 Place the magnetic side trims against the sides of the black frame, see Diagram 41.

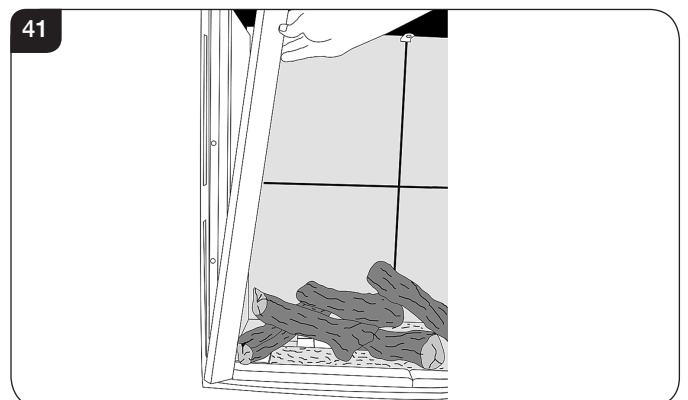

Installation Instructions

11. Lighting the Appliance

Note: The Emergency Shut Off switch must be in the ON position, refer to Section 2, User Instructions.

There are two ways of lighting the appliance:

1. Using the remote control handset.
2. Using the appliance's touch pad.

Thermostatic and Timer Remote Control

42



- 11.1 This remote controls the appliance from pilot ignition through to shut down.

There are 3 different modes available for controlling and operating the appliance:

1. Manual Mode
2. Temp Mode (Automatic)
3. Timer Mode (Automatic)

- 11.2 In **MANUAL MODE** you can:

Turn on the burners using the UP button.
Regulate the flame from high to low and back.
Switch between dual and single burners.
Turn off both burners leaving just the pilot burning .

In **TEMP MODE (Automatic)** you can:
Set the room temperature so the thermostat in the remote automatically maintains that temperature.

In **TIMER MODE (Automatic)** the appliance:
Turns on and off according to the set time periods.
Automatically regulates the room temperature during the set periods.

i **IMPORTANT: YELLOW FLAMES TYPICALLY APPEAR WHEN THE APPLIANCE HAS REACHED NORMAL OPERATING TEMPERATURE. THIS CAN TAKE UP TO 30 MINUTES.**

! **WARNING: IF THE APPLIANCE FAILS TO LIGHT OR BECOMES EXTINGUISHED IN USE, WAIT 3 MINUTES BEFORE ATTEMPTING TO RELIGHT.**

FOR FULL OPERATING INSTRUCTIONS AND TROUBLESHOOTING SEE USER SECTION.

Touchpad Control

43

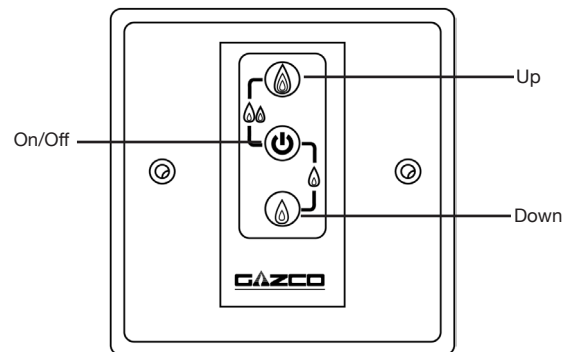

- 11.3 Press and hold the On/Off button until a short beep confirms the start up sequence has begun. Continuing beeps confirm the ignition process is in process. The appliance will light in the High flame position.
- 11.4 Press UP button to increase the flame height. Press the DOWN button to decrease the flame height. At the lowest point it goes to 'standby mode', (only pilot lit). Press the ON-OFF button again to turn the appliance off.

i **IMPORTANT: YELLOW FLAMES TYPICALLY APPEAR WHEN THE APPLIANCE HAS REACHED NORMAL OPERATING TEMPERATURE. THIS CAN TAKE UP TO 30 MINUTES.**

! **WARNING: IF THE APPLIANCE FAILS TO LIGHT OR BECOMES EXTINGUISHED IN USE, WAIT 3 MINUTES BEFORE ATTEMPTING TO RELIGHT.**

FOR FULL OPERATING INSTRUCTIONS AND TROUBLESHOOTING SEE USER SECTION.

1. Commissioning

- 1.1 Complete the Commissioning Checklist at the front of this manual covering:
- Flue checks
 - Gas checks
 - Log layout - flame picture
- For working pressure test, use the access panel at the gas connection ensuring the burner is in position. Refer to Installation Instructions, Section 3.
- 1.2 Ensure all safety checks listed in the Commissioning Section are completed, paying particular attention to the glass panel checks and securing of the glass frame.
- 1.3 Upon completion of the commissioning and testing of the installation and correct operation of the appliance, the installer must instruct the user how to operate the appliance.
- 1.4 Guide the user through the User Instructions paying particular attention to:
- a) Regular servicing (Section 9 of the User Instructions).
 - b) Ventilation (Section 10 of the User Instructions) - point out the ventilation positions where applicable.
 - c) Hot surfaces (Section 12 of the User Instructions).
 - d) How the appliance works with the touch pad control (Section 5 of the User Instructions).
 - e) How the appliance works with the remote control handset and the modes of operation (Section 2 of the User Instructions).
 - f) How to change settings in the auto mode and program modes of operation.
 - g) What to do if the appliance fails to operate (Section 13 of the User Instructions).
- 1.5 **In the unlikely event that the appliance is receiving interference from other electronic devices, re-programme the handset/Control box.**

Reprogramming handset/Control box

To access the control box see Servicing Instructions, Section 6 - Main Control Assembly.

- Press and hold the reset button on the control box until you hear two signals. After the second longer signal:
- Release the reset button and within 20 seconds:
- Press the DOWN button on the handset until you hear two additional short signals confirming the new code is set. If there is a single long signal the code learning sequence has failed or the wiring is incorrect.

Servicing Instructions

Servicing/Fault Finding Charts

1. Servicing Requirements

IMPORTANT – The glass panel on this appliance should be checked for any signs of damage on the front face of the glass panel (scratches, scores, cracks or other surface defects). If damage is observed, the glass panel must be replaced and the appliance must not be used until a replacement is installed. Under no circumstances should the appliance be used if any damage is observed. Please isolate the appliance until a replacement glass panel has been obtained and installed. Replacement glass panels can be purchased from Gazco via the dealer from which the appliance was purchased or any other Gazco distributor. This appliance must be serviced at least once a year by a competent person.

All tests must be carried out in accordance with the current Gas Safe recommendations.

- 1.1 Before any tests are undertaken on the appliance:
 –Conduct a gas soundness test for the property to ensure there are no gas leaks prior to starting work
 –Fully check the operation of the appliance

1.2 Special checks

- Clean the burner using a vacuum cleaner with a soft brush attachment. Ensure all debris is removed from the burner ports.
- Clean any lint or fluff from the pilot - pay particular attention to the aeration holes of the pilot
- Clean away any fluff or lint from under the burner
- Check the spark gap on the pilot is correct
- Ensure that the glass frame is secured correctly and that all retaining screws are in place.

- 1.3 Correct any faults found during the initial tests.
- 1.4 Re-commission the appliance in accordance with Commissioning Procedures of these instructions.
- 1.5 Advise the customer of any remedial action taken.

REPLACE BATTERIES BEFORE ATTEMPTING TO RECTIFY ANY FAULTS.

IF THE FIRE DOES NOT WORK, BUT HAS WORKED IN THE PAST CHECK THE EMERGENCY SHUT OFF SWITCH IN THE BOTTOM RIGHT CORNER BY THE DOOR IS SWITCHED ON, SEE USER SECTION, PAGE 7.

Electronic Control Valve Fault Analysis

| Symptom | Cause | Remedy |
|--|--|--|
| 3 Short beeps from control | Batteries low in appliance | Replace appliance batteries |
| No ignition, 5 second continuous tone (there may be several short beeps before) | 1. On/Off switch is in OFF position 2. Loose/damaged wire | 1. Move switch to ON position 2 Check interrupter block and wires |
| No ignition, no tone, motor turns slightly when operated | Receiver board damaged | Replace receiver |
| No pilot flame and control continues to spark | Thermocouple circuit wired incorrectly | Correct wiring |
| Pilot lights, control continues to spark, valve shuts down after 10 - 30 seconds | 1. No spark at pilot burner 2. Loose/damaged wire | 1. Rectify spark at pilot burner 2. Check interrupter and wires |
| Front burner can not be turned off - valve can be heard to operate. | Faulty Solenoid Valve | Replace Solenoid Valve |
| Front burner can not be turned off - no beep or noise from solenoid | 1. Faulty wire/ wire not connected. 2. Faulty receiver | 1. Replace wire/ solenoid. 2. Replace receiver |

IGNITION FUNCTIONAL CHECK 1

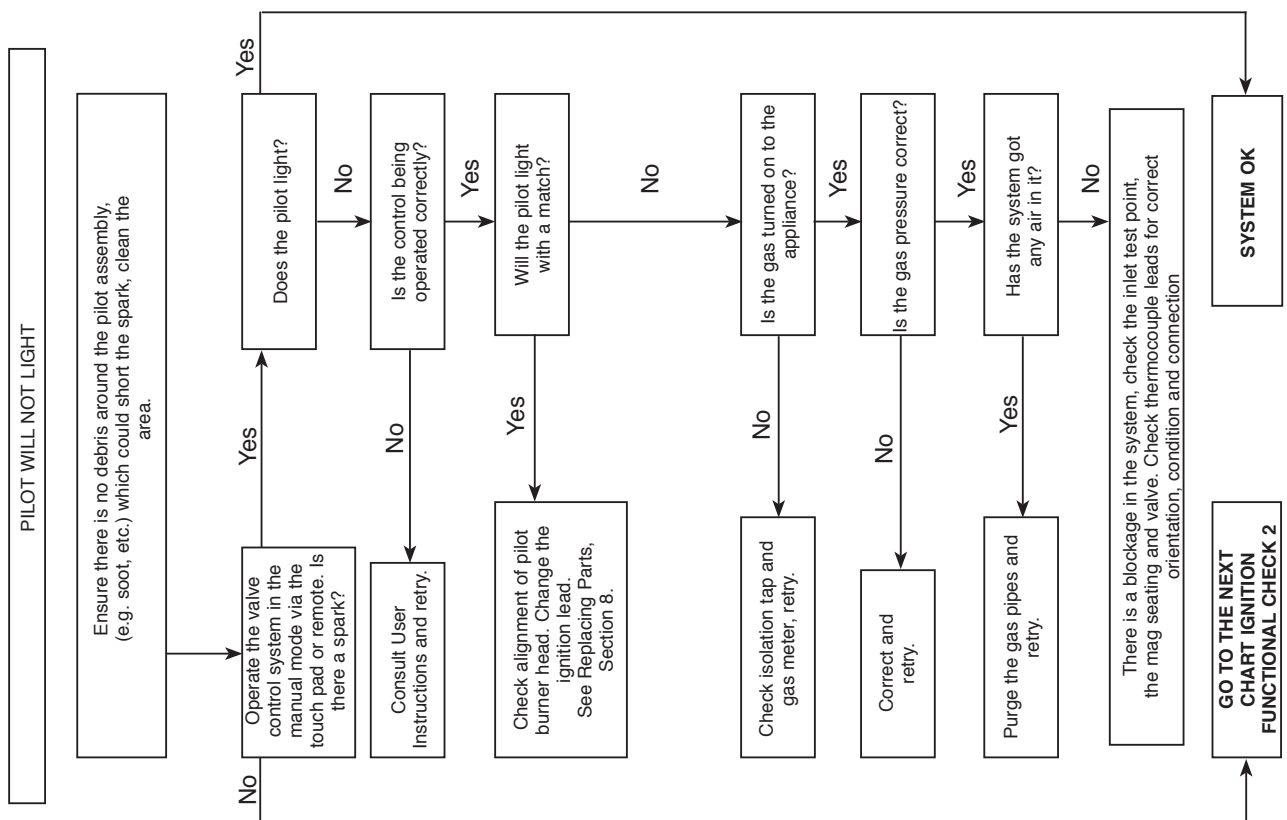

Servicing Instructions

Fault Finding Charts

FLAME FAILURE FUNCTIONAL CHECK 3

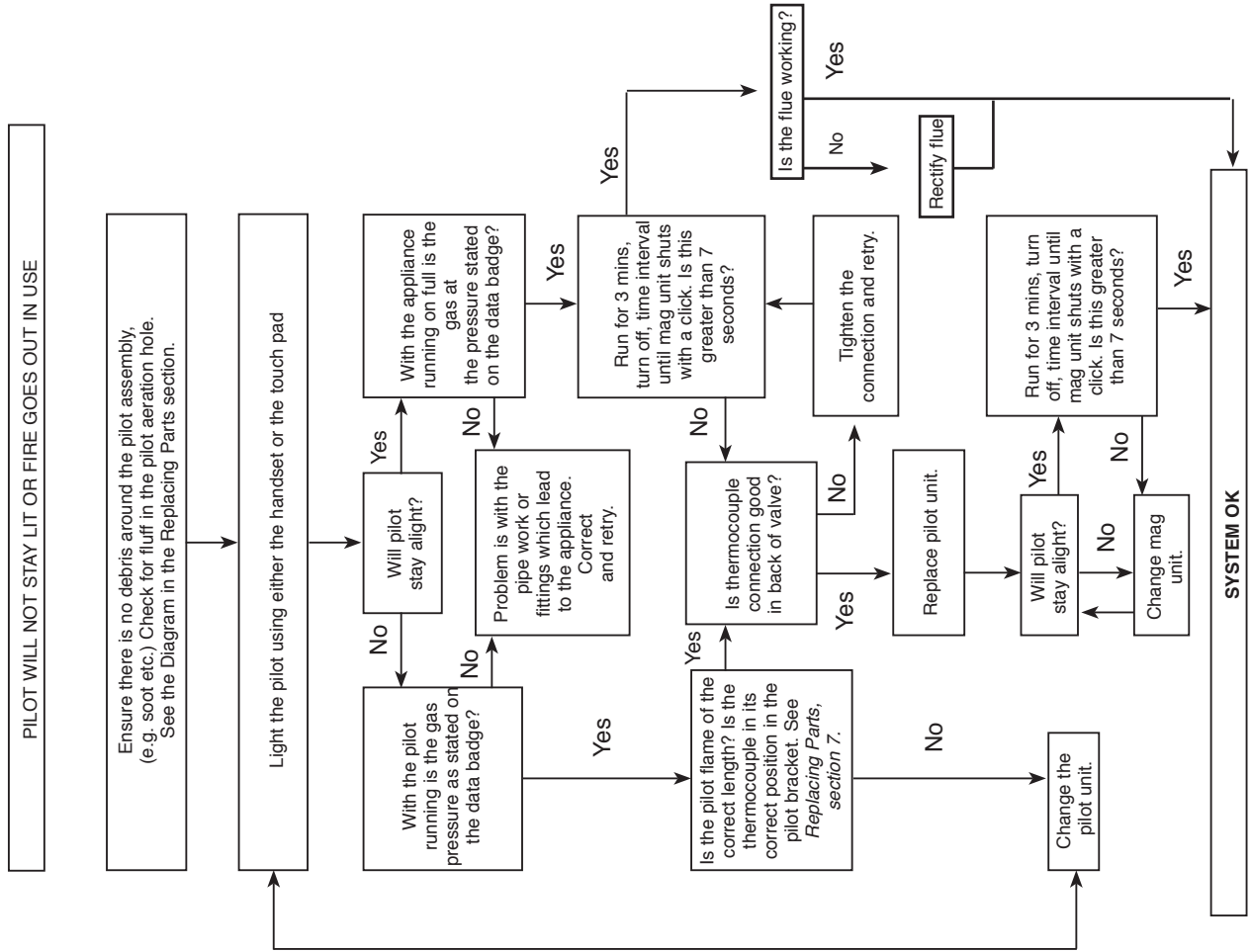

IGNITION FUNCTIONAL CHECK 2

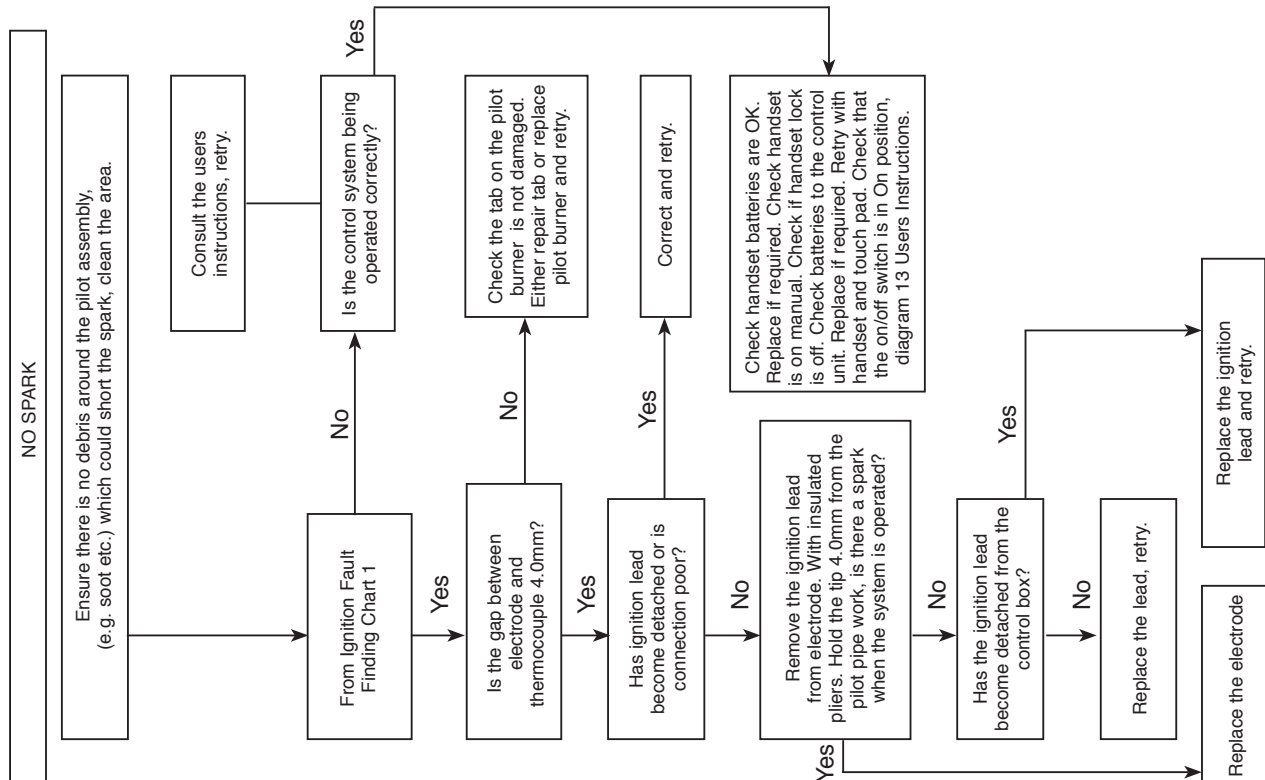

Servicing Instructions - Replacing Parts

1. General

- 1.1 All main components can be replaced without removing the appliance from its installation.

IT IS ESSENTIAL THAT THE GAS SUPPLY TO THE APPLIANCE IS TURNED OFF AT THE ISOLATION DEVICE BEFORE PROCEEDING FURTHER.

- 1.2 **DISCONNECT BATTERIES BEFORE SERVICING THE APPLIANCE.**

Removal of Flue

- 1.3 **If, for any reason, the flue has to be removed from the appliance, the seal must be replaced in the inner spigot.**
- 1.4 Access to the controls is restricted and the whole of the control assembly is to be removed as one unit. Refer to Section 6.

2. Window Frame Assembly

- 2.1 To remove the glass frame:
Remove the side trims, see Diagram 1.

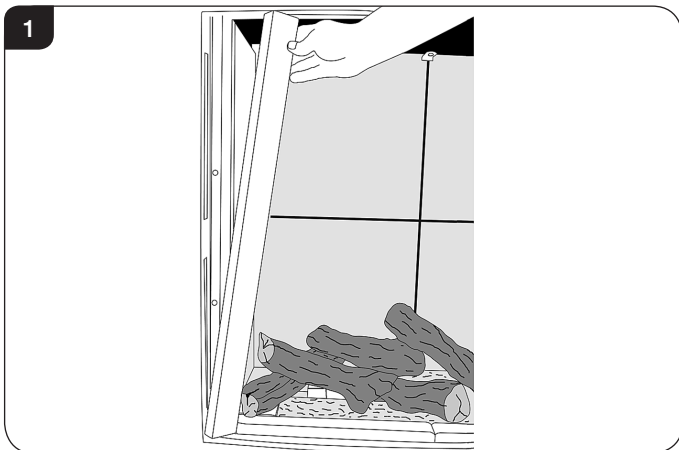

These are held on by magnets.

- 2.2 Lift out the bottom slotted trim, see Diagram 2.

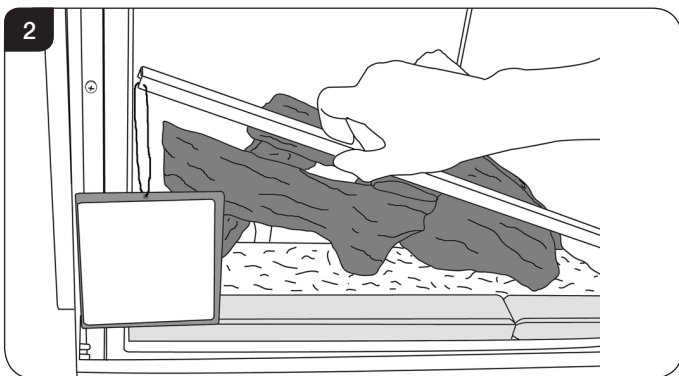

- 2.3 Remove all the screws around the frame.
(10 on the 800 model and 9 on the 1050 model)
Please note: The screws are located down both sides and along the bottom edge of the glass frame.

- 2.4 Lift the frame using the handle, up and over the lower edge. Take extreme care not to damage the paint, see Diagram 3.

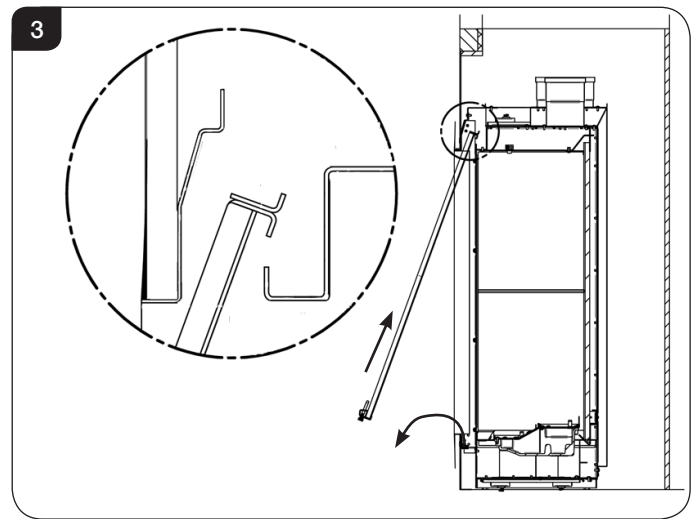

- 2.5 Lower the frame - the top edge will be hooked onto the top of the appliance.
- 2.6 Hold the sides of the frame and lift approximately 25mm and pull the top forward. This will release the door - Lower to clear the appliance.
- 2.7 To replace the glass frame place in position and tilt the bottom forward whilst ensuring the top hooks over the lip on the top of the appliance, see Diagram 6.
- 2.8 **Replace ALL of the glass frame securing screws ensuring that a screw is present in all fixing slots (10 in the Riva2 800 and 9 on the Riva2 1050).**
Tighten each of the screws in the bottom of the frame first and work up the Left and Right hand sides tightening each of the screws in turn, see Diagram 4.

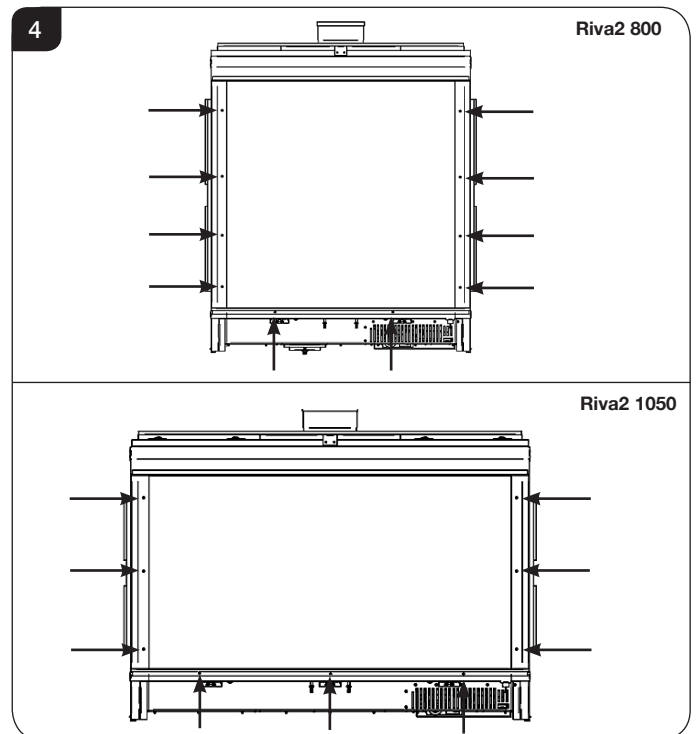

Servicing Instructions - Replacing Parts



UNDER NO CIRCUMSTANCES SHOULD THE APPLIANCE BE USED IF ANY OF THE GLASS FRAME RETAINING SCREWS ARE LOOSE OR MISSING.

3. Glass Window

- 3.1 Remove the two screws and clips from the underside of the glass frame. Lift the bottom of the glass out and drop down to release it from the bottom of the frame, see Diagram 5.

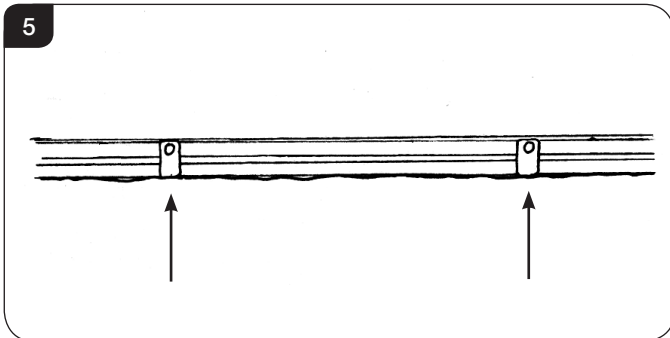

4. Vermiculite Panels

NOTE: RIVA2 FRONT AND REAR PANELS ARE IN TWO PIECES:

4.1 VERMICULITE PANELS

To remove the vermiculite panels it will be necessary to remove the logs and burner see Section 5.

- 4.2 Release the screws at the top of the side panels and rotate the brackets. Lean the top of the panel inwards and remove. Repeat with the other side, see Diagram 6.

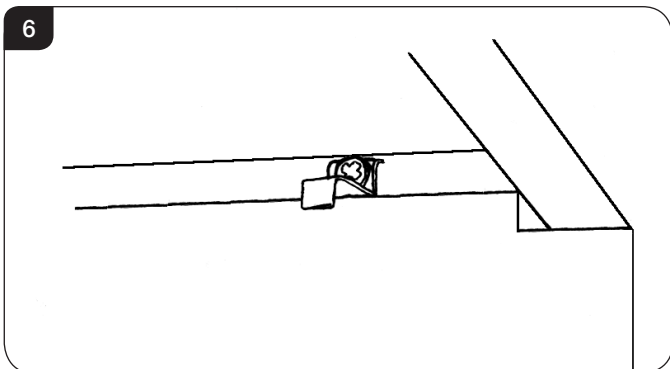

- 4.3 Remove the left and right hand front strips of vermiculite, along with the left and right hand L shaped panels.
- 4.4 To remove the rear panels loosen the retaining bracket at the top of the liners, see Diagram 7.

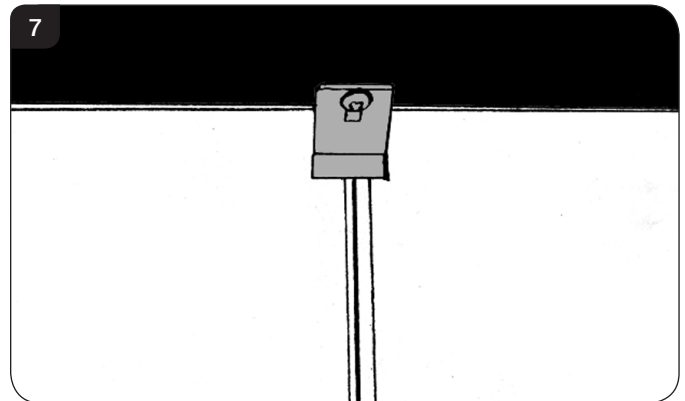

- 4.5 Lift the left hand liner off the lower support and lower it between the rear air guide (arrow A) and burner fixing bracket (arrow B). Lean the top forward and remove the liner, see Diagram 8.

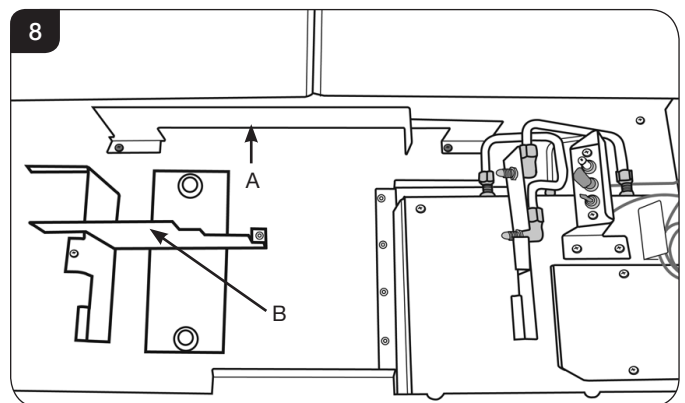

- 4.6 To remove the right hand liner slide it to the left hand side and repeat the above procedure, see Diagram 9.

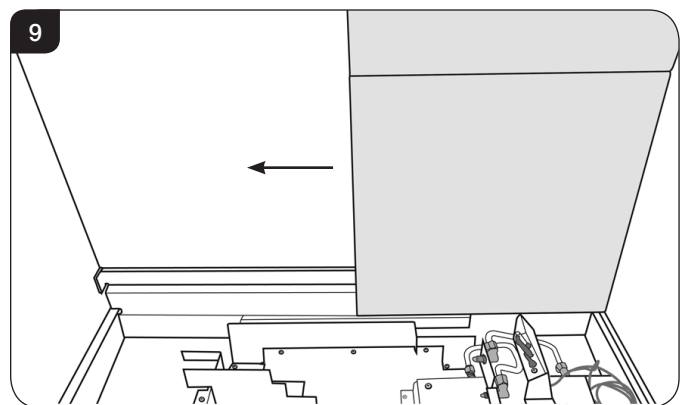

- 4.7 To replace the liners reverse the above procedure, noting the following points.

a) Replace the rear right hand liner first by lowering the bottom of the liner between the rear air guide and burner fixing bracket. Then lift and insert the top behind the top baffle but in front of the back support top rail.

Locate the bottom on the lower support rail and slide fully to the right hand side of the appliance with the chamber running centrally.

Repeat with the left hand liner.

Servicing Instructions - Replacing Parts

Ensure the two-piece rear panels are centralised, with the chamfers touching and pushed together.

b) When replacing the panels and the front strips, ensure the chamfers align where the liners touch, see Diagram 10.

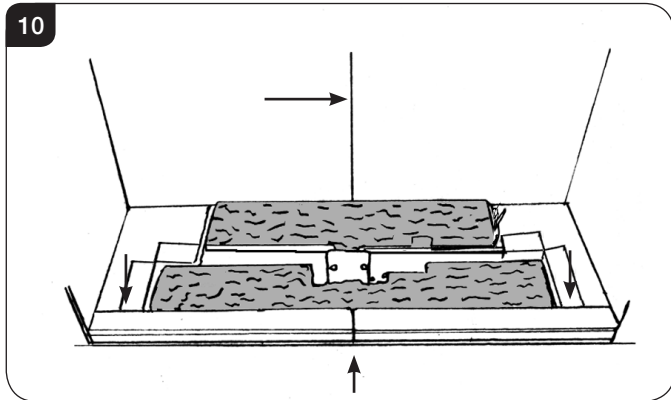

5. Burner Assembly

To replace the Burner Assembly:

- 5.1 Remove the Logs, Embaglow, Black Embers and the vermiculite.
Take care when removing the Embaglow.
- 5.2 Remove the vermiculite liners except for the two rear panels.
- 5.3 Remove the two burner fixing screws from the left side of the burner, see Diagram 11.

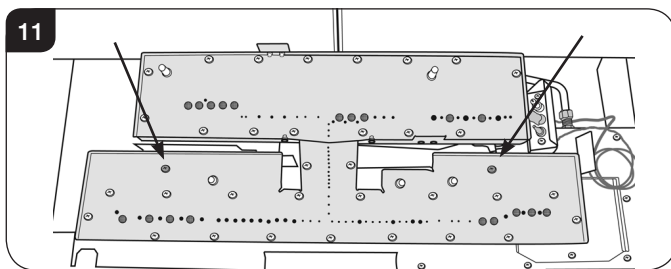

- 5.4 Move the burner to the left to clear the injector.

Refit in reverse order.

6. Main Control Assembly

- 6.1 To access the main control assembly, first remove:

- Window frame
- Vermiculite panels
- Burner Assembly

To remove the access panel:

- 6.2 Undo the two screws, see Diagram 12.

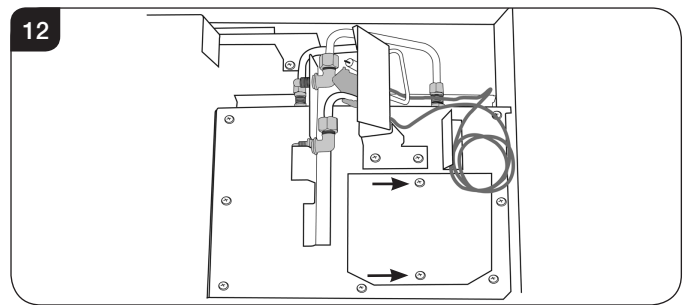

- 6.3 Isolate the gas supply at the isolation device and disconnect the gas inlet, see Diagram 13.

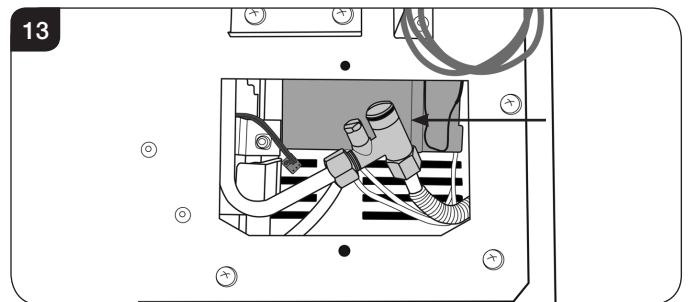

- 6.4 Remove the seven screws from the top of the control cover and a further four screws at the rear, see Diagram 14.

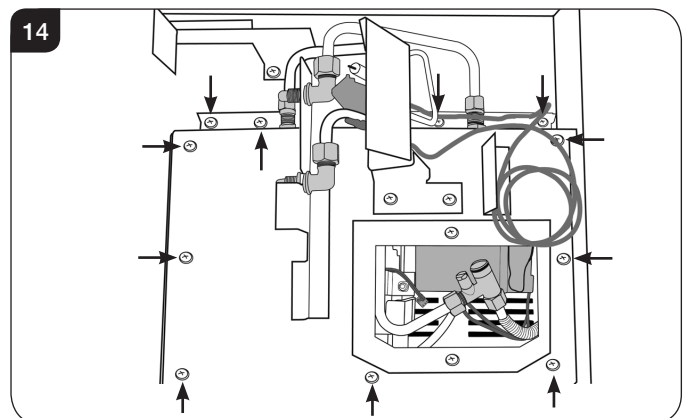

- 6.5 Remove the two screws securing the air guide at the rear of the control compartment, see Diagram 15.

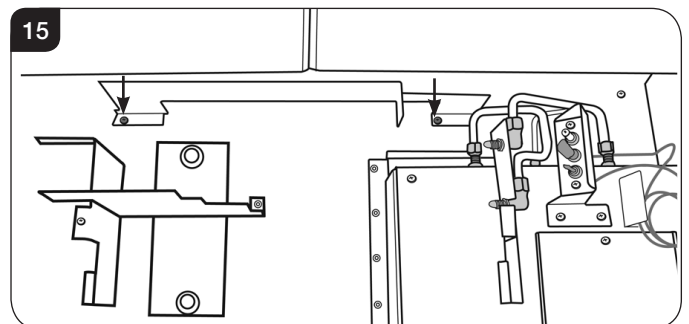

- 6.6 Release the On/Off switch from its bracket situated on the right hand side between the front of the firebox and the black trim, see Diagram 16.

Servicing Instructions - Replacing Parts

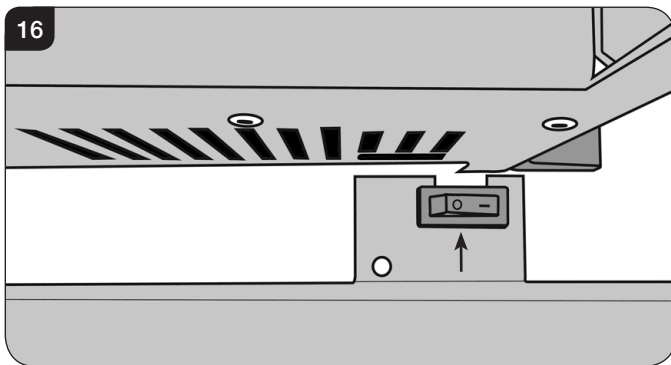

6.7 Before the assembly can be completely removed, the battery and touch pad lead must be disconnected from the right hand side of the control box, see Diagram 17.

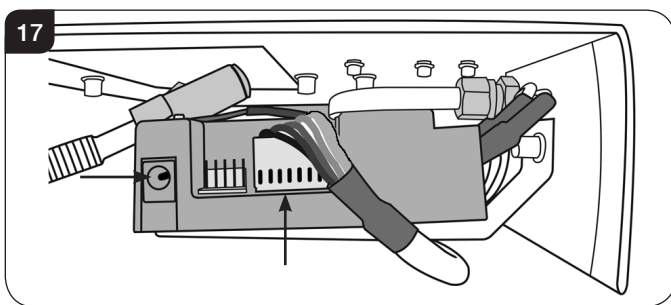

6.8 Remove the solenoid connector from the opposite side of the control box, see Diagram 18.

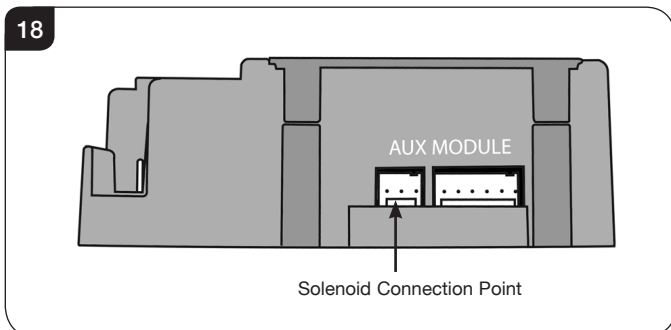

Feed the switch wire through the aperture in the front of the firebox. The control assembly can now be removed.

6.9 Replace in reverse order. When replacing the screws, locate the two screws on the top rear corners first. All the top screws are M5 x 10 machine screws. The rear four screws are all self tapping screws.

7. Pilot Unit Assembly

The pilot assembly consists of four components which can be individually changed:

- 7a) Pilot burner bracket
- 7b) Pilot injector
- 7c) Electrode
- 7d) Thermocouple

7.1 Before commencing work on the pilot the Burner Assembly must be removed, see Section 5.

7a Pilot Burner Bracket

- 7.2 Remove the electrode, see 7b.
- 7.3 Remove the thermocouple, see 7d.
- 7.4 Remove the pilot pipe by disconnecting at both ends. Ensure Pilot injector is retained.
- 7.5 Remove the two screws securing the bracket.

The pilot burner bracket can now be removed.
- 7.6 Replace in reverse order.

Ensure the black vidaflex cover is pushed up to the back of the pilot bracket covering the thermocouple and ignition lead.

7b Electrode

- 7.7 Pull the ignition lead off the electrode and undo the retaining nut, see Diagram 19.

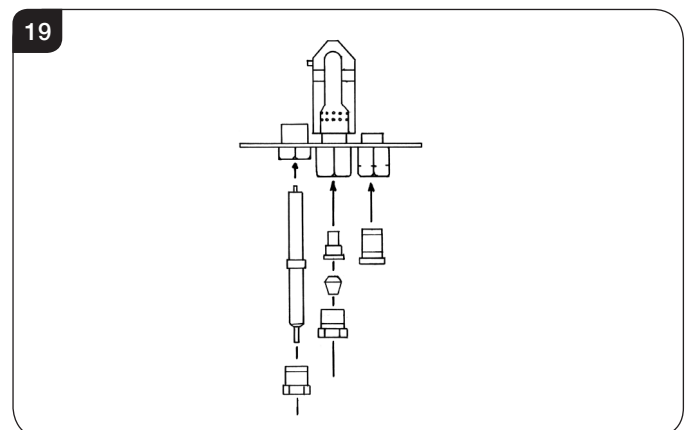

- 7.8 Replace with a new electrode. Do not over-tighten the nut; this could break the component.
- 7.9 Replace the ignition lead.

7c Pilot Injector

- 7.10 Undo the pilot pipe from the control cover and from the underside of the pilot burner and remove the pipe. The injector drops out from the burner, see Diagram 20.

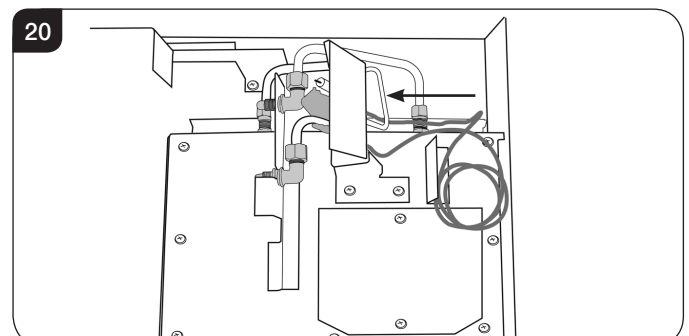

Servicing Instructions - Replacing Parts

7d Thermocouple

- 7.11 To remove the thermocouple the control assembly will have to be removed, see Section 6.
- 7.12 Disconnect the thermocouple from the gas valve/interrupter.
- 7.13 Undo the thermocouple nut in the back of the pilot bracket half a turn. This releases the thermocouple.
- 7.14 When replacing with a new thermocouple, take care to bend the new component to the same shape as the thermocouple just removed.
- 7.15 To refit the thermocouple into the pilot bracket, ensure it is pushed fully into the hole. There is a stop on the thermocouple to set the height.
- 7.16 Lock the retaining nut just enough to grip the thermocouple and connect the thermocouple to the valve/interrupter and **take care not to over-tighten.**

8. Ignition Lead

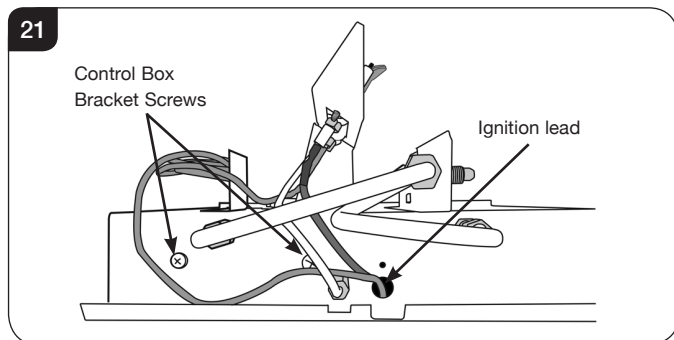

- 8.1 To replace the ignition lead remove the Main Control Assembly, see Section 6.
Carefully remove the ignition lead from the electrode.
- 8.2 The Control Box bracket is held in place with 2 x 10mm M5 screws. Remove the screws and withdraw the bracket with the control box for access.
- 8.3 Release the cables from the clip on the underside of the assembly. This allows the control box to be pulled forward.
- 8.4 Feed the ignition lead through the aperture in the rear of the control cover, Diagram 21. Pull the control box to expose the ignition lead.

Note the direction of the lead. The new lead must follow exactly the same route.
NOTE: THE IGNITION LEAD MUST NOT PASS IN FRONT OF THE CONTROL BOX AS THIS CAN DAMAGE THE SENSITIVE ELECTRONICS.

When replacing the lead re-use the black vidaflex. Ensure it is pushed up to the rear of the electrode. Use a new cable tie on the inside of the control cover. Reseal the cover plate with a suitable silicone sealant.

9. Gas Valve

To change the gas valve:

- 9.1 First remove the control assembly, see Section 6, then release the gas inlet pipe, Diagram 22, Arrow A.
- 9.2 The remove the thermocouple from the interrupter block and release the two thermocurrent cables.
- 9.3 Release the pilot pipe, Diagram 22, B and release the injector feed pipe, Diagram 22, C.
- 9.4 Remove the wiring loom by inserting a small flat screwdriver in the top of the white plug, Diagram 23.
- 9.5 Remove the two screws, Diagram 22, D. The valve can now be freed.

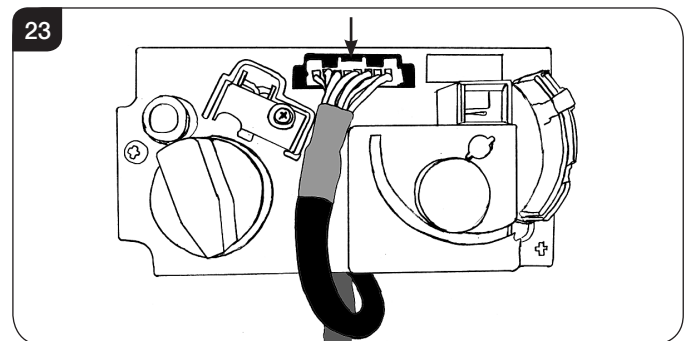
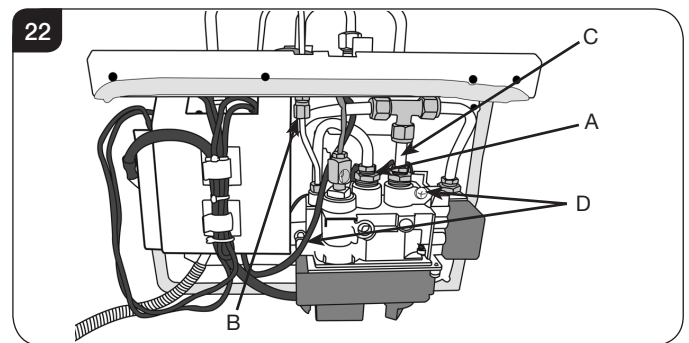

10. Magnetic Safety Valve

Remove the main control assembly, See Section 6.

- 10.1 To replace the magnetic safety valve:
Undo the thermocouple from the interrupter block and remove the two thermocurrent cables. Then unscrew the interrupter block from the back of the valve.
- 10.2 Undo the silver magnetic valve retaining nut on the back of the valve and gently tap out the mag valve.
- 10.3 Replace with a new unit and reassemble in reverse order.

Servicing Instructions - Replacing Parts

11. Control Box

- 11.1 To replace the control box first remove the main control assembly, See Section 6.
- 11.2 Release the cables from the clip on the underside of the assembly. Then remove the sealing plate from the rear of the control box assembly.
- 11.3 Pull the control box forward and remove the ignition lead followed by the two thermo current cables by removing the two screws.
- 11.4 Remove the eight wire loom from the control box.

When replacing the sealing plate on the rear of the control cover use a suitable silicone sealant.

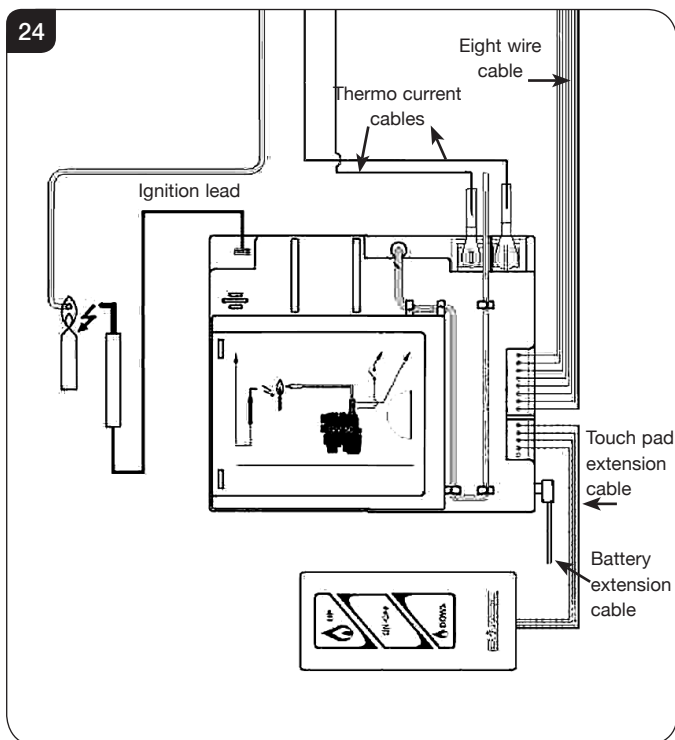

- 11.5 After replacing the control box it will be necessary to reprogram the handset.

To access the control box see Servicing Instructions, Section 6 - Main Control Assembly.

- Press and hold the reset button on the control box until you hear two signals. After the second longer signal:
- Release the reset button and within 20 seconds:
- Press the DOWN button on the handset until you hear two additional short signals confirming the new code is set. If there is a single long signal the code learning sequence has failed or the wiring is incorrect.

12. Main Injector

- 12.1 To change the main injector undo the injector feed pipe and remove the lock nut from the injector.
- 12.2 Replace with the correct size injector(s).

13. Solenoid

- 13.1 Disconnect the pipes at either end of the Solenoid - the pipe connected to the Tee-Piece will need to be removed, see Diagram 25.

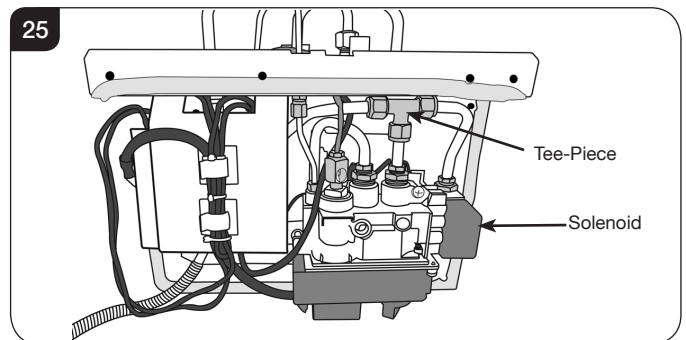

- 13.2 Remove the Solenoid cable from the Control Box and replace Solenoid.
- 13.3 Fit new Solenoid in reverse order.

14. Primary Aeration Plate

NOT ALL MODELS HAVE AERATION PLATES. REFER TO NOTE AT BEGINNING OF INSTALLATION INSTRUCTIONS.

- 14.1 Remove the Burner Assembly as described in Servicing section 5.
- 14.2 Remove the fixing screw and remove the plate off the venturi.
- 14.3 Replace with the correct size plate and secure with the screw.

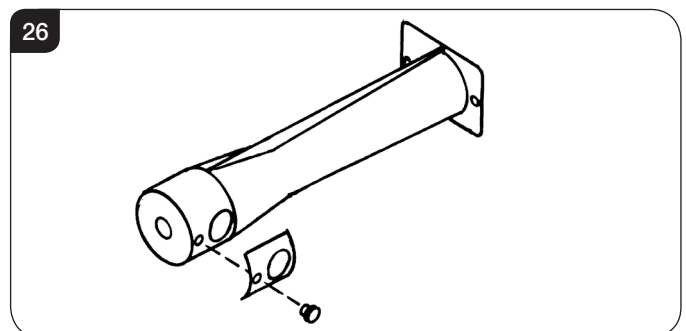

Servicing Instructions - Replacing Parts

15. Changing Between Gas Types

In order to change between gas types, it will be necessary to change the following items:

Burner Assembly: - NG: GZ8234N
- LPG: GZ8234P

Control Assembly:

| | NG | LPG |
|------|----------|----------|
| 800 | GZ11072N | GZ11072P |
| 1050 | GZ11073N | GZ11073P |

Data Badge - PR0393 RIV 2

A kit of parts is available for this, always quote the Model number and Serial number when ordering any spare parts.

NOTE: THE CONTROL VALVE IS FACTORY PRESET FOR THE CORRECT GAS TYPE AND MODEL, A NEW UNIT WILL NEED TO BE ORDERED WHEN CHANGING BETWEEN GAS TYPES.

16. Short Spares List

| COMPONENT | RIVA 2 - 800 | | RIVA 2 1050 | |
|-------------------------------|--------------|-----|-------------|-----|
| | NG | LPG | NG | LPG |
| VERMICULITE BACK PANEL x 2 | CE0780 | | CE0773 | |
| VERMICULITE SIDE PANEL (LH) | CE0974 | | CE0976 | |
| VERMICULITE SIDE PANEL (RH) | CE0975 | | CE0977 | |
| VERMICULITE BASE PANEL (LH) | CE0781 | | CE0776 | |
| VERMICULITE BASE PANEL (RH) | CE0782 | | CE0832 | |
| VERMICULITE FRONT PANEL (LH) | CE0774 | | CE0833 | |
| VERMICULITE FRONT PANEL (RH) | CE0796 | | CE0834 | |
| BLACK REEDED BACK PANEL x 2 | CE1253 | | CE1260 | |
| BLACK REEDED SIDE PANEL (LH) | CE1251 | | CE1259 | |
| BLACK REEDED SIDE PANEL (RH) | CE1252 | | CE1258 | |
| BLACK REEDED BASE PANEL (LH) | CE1257 | | CE1264 | |
| BLACK REEDED BASE PANEL (RH) | CE1255 | | CE1262 | |
| BLACK REEDED FRONT PANEL (LH) | CE1256 | | CE1263 | |
| BLACK REEDED FRONT PANEL (RH) | CE1254 | | CE1261 | |

Servicing Instructions - Replacing Parts

16. Short Spares List (continued)

| COMPONENT | RIVA 2 - 800 | | RIVA 2 1050 | |
|----------------------------|---------------|--------------|---------------|--------------|
| | NG | LPG | NG | LPG |
| PILOT INJECTOR | PI0069 | PI0070 | PI0069 | PI0070 |
| FRONT INJECTOR | IN0002 | IN0049 | IN0002 | IN0049 |
| REAR INJECTOR | IN0039 | IN0052 | IN0039 | IN0052 |
| BURNER ASSEMBLY | GZ11094N | GZ11094P | GZ11094N | GZ11094P |
| FRONT AERATION PLATE | G20 - GZ11374 | G31 - ME1348 | G20 - GZ11374 | G31 - ME1348 |
| REAR AERATION PLATE | G20 - ME1350 | G31 - ME1348 | G20 - ME1350 | G31 - ME1348 |
| ELECTRODE | PI0075 | | PI0075 | |
| THERMOCOUPLE | PI0074 | | PI0074 | |
| MAG UNIT | GC0166 | | GC0166 | |
| IGNITION LEAD | GC0125 | | GC0125 | |
| GAS VALVE | GC0123 | | GC0123 | |
| CONTROL BOX | EL0564 | | EL0564 | |
| LATCHING SOLENOID | EL0563 | | EL0563 | |
| REMOTE CONTROL | EL0568 | | | |
| INTERRUPTOR BLOCK | GC0124 | | GC0124 | |
| THERMOCURRENT CABLE | GC0136 | | GC0136 | |
| THERMOCURRENT SWITCH CABLE | GC0128 | | GC0128 | |
| TOUCH PAD | EL0570 | | EL0570 | |
| TOUCH PAD LEAD | GC0144 | | GC0144 | |
| BATTERY HOLDER | EL0410 | | EL0410 | |
| BATTERY HOLDER CABLE | GC0138 | | GC0138 | |
| CONTROL BOX/VALVE CABLE | GC0133 | | GC0133 | |
| EMBAGLOW | GZ8471 | | GZ8471 | |
| VERMICULITE (LOOSE) | CE0746 | | CE0746 | |
| LOG SET | CE0777 | | CE0777 | |
| GLASS PANEL | GZ8487 | | GZ8488 | |

Service Records

1ST SERVICE

Date of Service:.....
Next Service Due:.....
Signed:.....
Retailer's Stamp/Gas Safe Registration Number

3RD SERVICE

Date of Service:.....
Next Service Due:.....
Signed:.....
Retailer's Stamp/Gas Safe Registration Number

5TH SERVICE

Date of Service:.....
Next Service Due:.....
Signed:.....
Retailer's Stamp/Gas Safe Registration Number

7TH SERVICE

Date of Service:.....
Next Service Due:.....
Signed:.....
Retailer's Stamp/Gas Safe Registration Number

9TH SERVICE

Date of Service:.....
Next Service Due:.....
Signed:.....
Retailer's Stamp/Gas Safe Registration Number

2ND SERVICE

Date of Service:.....
Next Service Due:.....
Signed:.....
Retailer's Stamp/Gas Safe Registration Number

4TH SERVICE

Date of Service:.....
Next Service Due:.....
Signed:.....
Retailer's Stamp/Gas Safe Registration Number

6TH SERVICE

Date of Service:.....
Next Service Due:.....
Signed:.....
Retailer's Stamp/Gas Safe Registration Number

8TH SERVICE

Date of Service:.....
Next Service Due:.....
Signed:.....
Retailer's Stamp/Gas Safe Registration Number

10TH SERVICE

Date of Service:.....
Next Service Due:.....
Signed:.....
Retailer's Stamp/Gas Safe Registration Number

Gazco Limited, Osprey Road, Sowton Industrial Estate, Exeter, Devon, England EX2 7JG
Technical Customer Services (01392) 261950 Fax: (01392) 261951
E-mail: technicalservices@gazco.com

A member of the Stovax Group