



# Jeoman

## *The Dartmoor*

---



**LOG EFFECT GAS STOVE -  
CONVENTIONAL FLUE  
SINGLE AND DOUBLE DOOR**

**INSTALLATION, SERVICING  
AND USER INSTRUCTIONS**



For use in Great Britain and the Republic of Ireland (GB, IE)

These instructions are to be left with the customer and should be read carefully and kept in a safe place.

They will be necessary when servicing the appliance



### **IMPORTANT**

**THIS APPLIANCE MUST ONLY BE OPENED, INSTALLED AND SERVICED BY A CORGI REGISTERED ENGINEER**

# Contents

---

<b><u>APPLIANCE COMMISSIONING CHECKLIST</u></b>	<b>3</b>
---	----------

<b><u>GUARANTEE</u></b>	<b>3</b>
-------------------------	----------

<b><u>USER INSTRUCTIONS</u></b>	<b>4</b>
---------------------------------	----------

<b><u>INSTALLATION INSTRUCTIONS</u></b>	<b>9</b>
---	----------

Technical Specifications	9
--------------------------	---

Site Requirements	10
-------------------	----

Installation	11
--------------	----

<b><u>COMMISSIONING</u></b>	<b>15</b>
-----------------------------	-----------

<b><u>SERVICING INSTRUCTIONS</u></b>	<b>16</b>
--------------------------------------	-----------

Fault Finding	16
---------------	----

How to Replace Parts	18
----------------------	----

Basic Spare Parts List	23
------------------------	----

Service Records	24
-----------------	----

# APPLIANCE COMMISSIONING CHECKLIST

## IMPORTANT NOTICE

Explain the operation of the stove to the end user, hand the completed instructions to them for safe keeping, as the information will be required when making any guaranteed claims.

FLUE CHECK	PASS	FAIL
1. Flue is correct for appliance		
2. Flue flow test N/A		
3. Spillage test N/A		
GAS CHECK		
1. Gas soundness & let by test		
2. Standing pressure test	mb	
3. Appliance working pressure (on High Setting) NB All other gas appliances must be operating on full	mb	
4. Gas rate	m <sup>3</sup> /h	
5. Does ventilation meet appliance requirements		
6. Have controls been upgraded (Upgradeable models only)	8455 Standard	YES NO
	8456 Programmable Thermostatic and Timer	YES NO

## DEALER AND INSTALLER INFORMATION

Dealer .....

.....

.....

Contact No.....

Date of Purchase.....

Model No.....

Serial No.....

Gas Type.....

Installation Company .....

.....

Engineer .....

Contact No.....

Corgi Reg No.....

Date of Installation .....

This product is guaranteed for 2 years from the date of installation, as set out in the terms and conditions of sale between Yeoman and your local Yeoman dealer. **This guarantee will be invalid, to the extent permitted by law, if the above Appliance Commissioning Checklist is not fully completed by the installer and available for inspection by a Yeoman engineer.** The guarantee will only be valid during the second year, to the extent permitted by law, if the annual service recommended in the Instructions for Use has been completed by a Corgi registered engineer, and a copy of the service visit report is available for inspection by a Yeoman engineer.

# USER INSTRUCTIONS

## 1. GENERAL

- 1.1 A competent person must carry out installation and servicing.
- 1.2 In all correspondence, please quote the appliance type and serial number, which can be found on the databadge located on a tag/chain behind the appliance.
- 1.3 Ensure that curtains are not positioned above the appliance and there is at least 300mm between the sides of the appliance and any curtains.
- 1.4 If any cracks appear in the glass panel do not use the appliance until the panel has been replaced.
- 1.5 This product is guaranteed for 2 years from the date of installation, as set out in the terms and conditions of sale between Yeoman and your local Yeoman dealer. Please consult with your local Yeoman dealer if you have any questions. In all correspondence always quote the Model Number and Serial Number.
- 1.6 Any combustible shelves or surrounding furniture must only be fitted in accordance with the minimum dimensions detailed in Diagram 1.

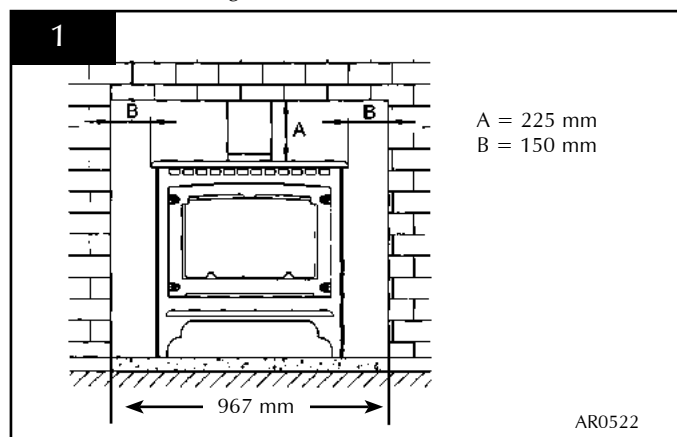

- 1.7 Contact a competent service engineer to carry out relevant spillage checks etc. following home improvements carried out after installation of this stove (e.g. the fitting of double glazing).

## 2. LIGHTING THE STOVE

- 2.1 The controls are at the lower right of the stove:
  - the right-hand knob ignites the pilot
  - the left-hand knob controls the main burner
- 2.2 If you have upgraded your stove to operate with remote control, you must have the pilot lit before you can use the remote (see Section 4 below)
  - Use the following instructions to light the pilot

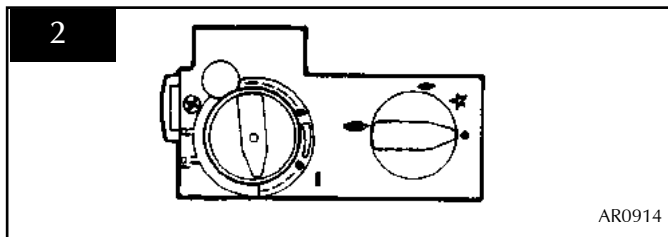

### Pilot Ignition

- Ensure the left-hand control knob is pointing to off (●)
  - Ensure that the right-hand control knob is pointing to off (●)
  - Press in the right-hand control knob and rotate it left until a click is heard
  - Keep pressing in and the knob is pointing to pilot (★)
- The pilot should now light. If the pilot has not lit, repeat the procedure until it lights
- Hold the control knob pressed in for 10 seconds and then release it
- The pilot stays lit. If the pilot goes out, repeat the steps.

### Regulating the Main Burner

- 2.3 • Turn the right-hand control to main burner (↔).
- The temperature and flame height is now controlled by left-hand knob
- Turn the left-hand knob to low fire (↔) to light the main burner. Turn the knob anticlockwise to increase the flame height and clockwise to decrease the flame height.
- THE YELLOW FLAMES WILL APPEAR WHEN THE FIRE HAS REACHED SUFFICIENT HEAT - TYPICALLY 10 TO 20 MINUTES.**
- 2.4 **If the pilot flame is extinguished, intentionally or unintentionally, do not relight the stove for at least 3 minutes.**

## 3. TURNING THE STOVE OFF

- 3.1 To turn the burner off,
  - Turn the left-hand control knob to point to off (●)The main burner goes out leaving the pilot burning.
- 3.2 To turn the pilot off:
  - Turn the right-hand control knob to point to off (●)

## 4. UPGRADING YOUR STOVE

- 4.1 Your stove is fitted with a control valve that can be upgraded to battery powered Remote Control. This upgrade can be fitted by anyone capable of simple DIY jobs. Your Yeoman dealer keeps two versions of the remote:
- 4.2 **STANDARD REMOTE CONTROL (Yeoman PART NUMBER YM-8455)**

# USER INSTRUCTIONS

This remote controls the gas stove after the pilot has been lit to:

- Turn on the main burner
- Regulate the flame from low to high and back
- Turn off the burner leaving just the pilot burning

## 4.3 THERMOSTATIC AND TIMER REMOTE CONTROL (Yeoman PART NUMBER YM-8456)

This remote controls the gas stove after the pilot has been lit. In 'MANUAL MODE' you can:

- Turn on the main burner
- Regulate the flame from low to high and back
- Turn off the burner leaving just the pilot burning

In 'AUTO MODE' you can:

- Set the room temperature so the stove automatically maintains that temperature

In 'TIMER MODE' the stove:

- Turns on and off according to the set time periods
- Automatically regulates the room temperature during the set periods

**NOTE: WHEN OPERATING THE FIRE IN TEMP OR TIMER MODE, THE PILOT REMAINS LIT AND THE FIRE THEN AUTOMATICALLY SWITCHES ON AT PROGRAMMED TIMES TO BRING THE ROOM TO THE SET TEMPERATURE WHETHER OR NOT YOU ARE IN THE ROOM.**

**NEVER LEAVE ANY COMBUSTIBLE MATERIALS WITHIN 1 METRE OF THE FRONT OF THE APPLIANCE.**

## 5. CLEANING THE FIRE

**WARNING: DO NOT ATTEMPT TO CLEAN THE STOVE UNTIL IT IS COLD. THE STOVE RETAINS ITS HEAT FOR A CONSIDERABLE TIME AFTER SHUTDOWN.**

**NOTE: THE CAST IRON DOOR IS HEAVY, TAKE EXTREME CARE WHEN HANDLING.**

### 5.1 Single Door

To open the door and access the interior:

- Turn the right-hand rosette 90°, Diagram 3
- Pull the door open

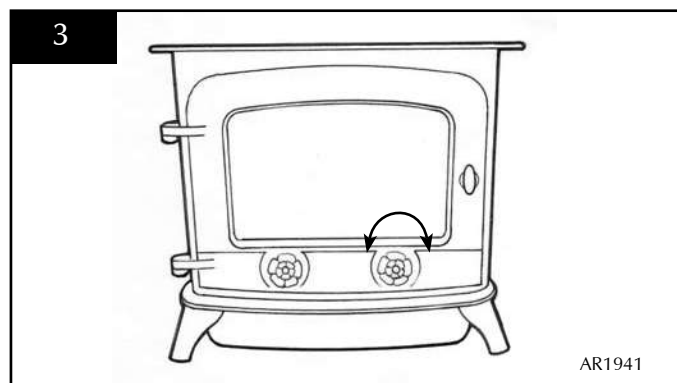

### Double Door

To open the door:

- Turn the knob on the right door to release the catch, Diagram 4

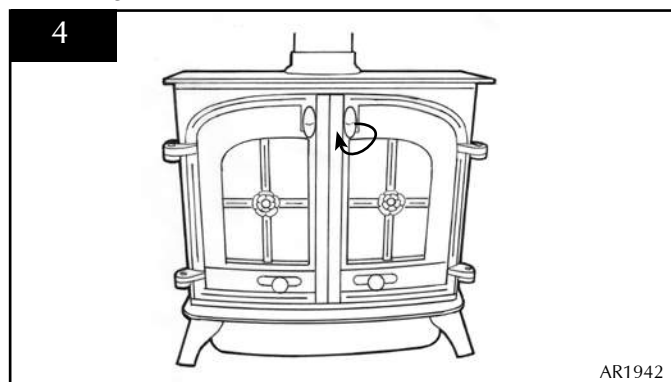

- Remove the glass frame by undoing the six screws, Diagram 5

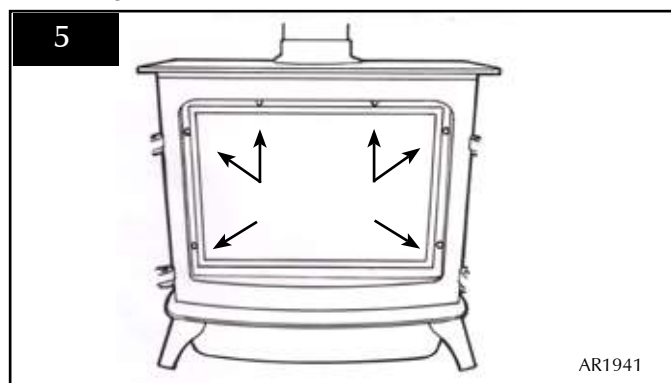

- Lower the frame down to clear the top edge before lifting clear, Diagram 6

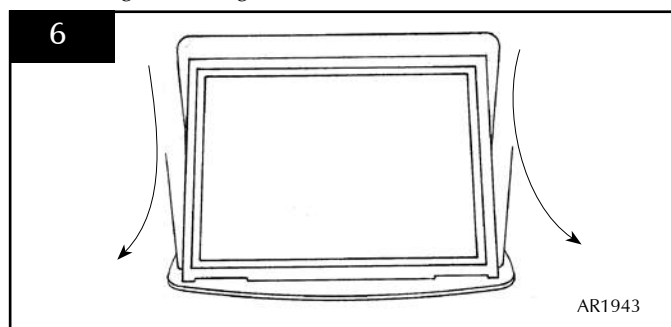

- Remove the ceramic fuel bed components and place to one side  
You must protect floor covers and **handle the ceramic logs with care**

5.3 The logs should not require cleaning:

- Do not use a vacuum cleaner or brush to clean the logs
- Remove any large debris by hand
- Make sure no debris blocks the burner ports

5.4 See Section 6 to replace the ceramic logs.

# USER INSTRUCTIONS

5.5 Use a damp cloth to clean the outer casing of the stove.

## Advice on Handling and disposal of fire ceramics

The fuel effect and side panels in this appliance are made from Refractory Ceramic Fibre (RCF), a material which is commonly used for this application.

Protective clothing is not required when handling these articles, but we recommend you follow normal hygiene rules of not smoking, eating or drinking in the work area and always wash your hands before eating or drinking.

To ensure that the release of RCF fibres are kept to a minimum, during installation and servicing a HEPA filtered vacuum is recommended to remove any dust accumulated in and around the appliance before and after working on it. When servicing the appliance it is recommended that the replaced items are not broken up, but are sealed within heavy duty polythene bags and labelled as RCF waste.

RCF waste is classed as stable, non-reactive hazardous waste and may be disposed of at a licensed landfill site.

Excessive exposure to these materials may cause temporary irritation to eyes, skin and respiratory tract; wash hands thoroughly after handling the material.

## 6. FUEL BED ARRANGEMENT

- Open the door as set out in Section 5 above

The fuel bed consists of 5 logs and 2 ash panels. The logs have letters A,B,C,D and E moulded into them for identification.

- 6.1
- Take the rear log A
  - Place it up against the rear of the fire sitting on the two flat ledges of the burner. The two legs of the log should sit between the rear burner ports. See Diagram 7
  - Ensure there is an equal gap between the sides of the firebox at each end of the log

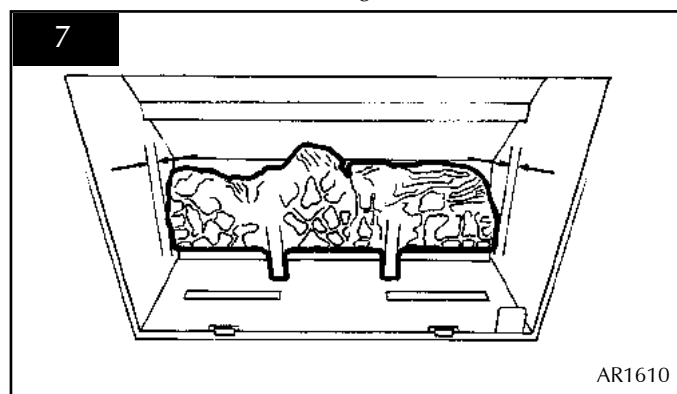

- 6.2
- Place log B on the left-hand side of the burner with the location bar on its underside slid into the long slot of the burner

- Make sure the log is as far left as possible, Diagram 8

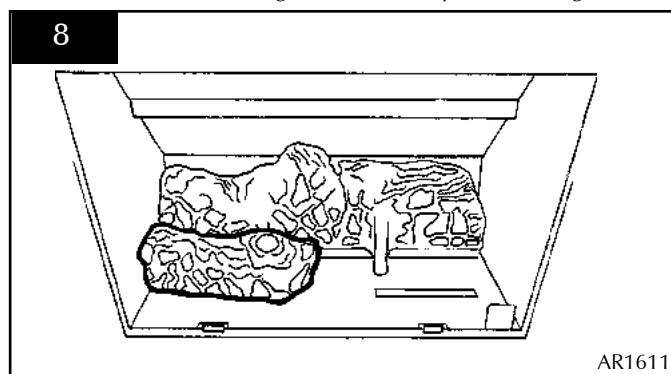

- 6.3
- Place log C on the right-hand side of the burner with the location bar on its underside slid into the long slot of the burner.
  - Make sure the log is as far right as possible, Diagram 9

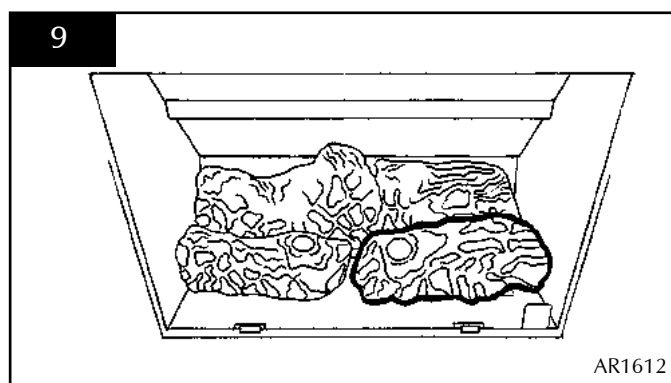

- 6.4
- Place log D across from the rear log A to log B on the left-hand side. There are cut-outs in both logs for location, Diagram 10

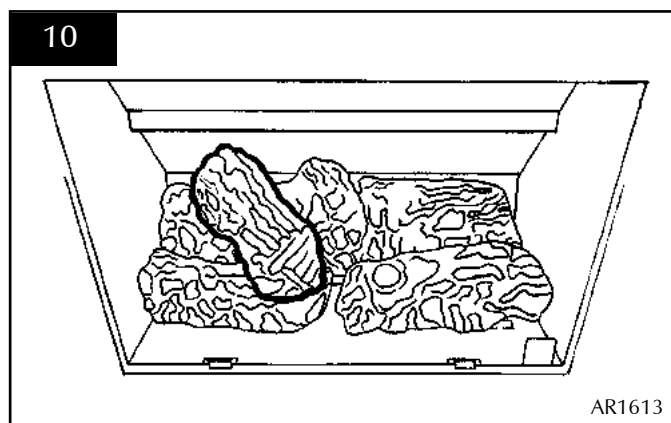

- 6.5
- There are two ash panels to lie across the front of the burner.
  - Place the panel with the flat edge facing the left side of the firebox. There are location holes on this log fitting the screw holes on the burner.

# USER INSTRUCTIONS

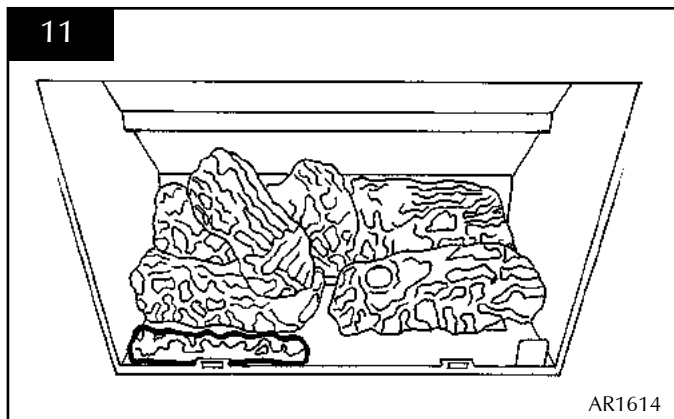

- Place the second ash panel to the right of the first, the pointed end of this panel fitting the V shape and fitting the screw holes on the burner.
- Ensure that both logs are horizontal to the burner ports.

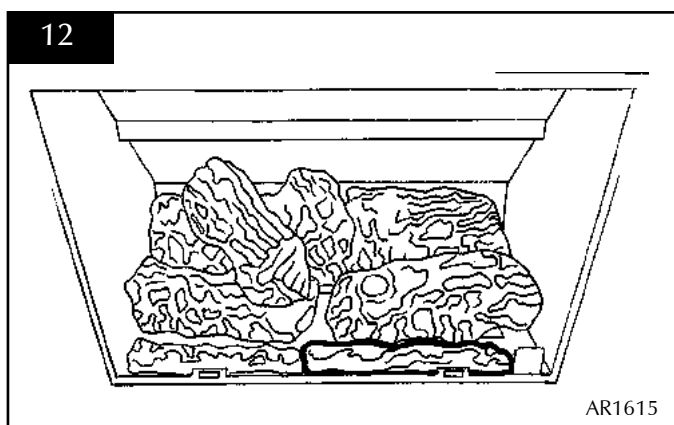

- 6.6
- Place log E across from the rear of log A to log C on the right-hand side using the shaped cut-outs as location guides. The front of the log should sit on the front ash panels and should fit tight to log C, Diagram 13

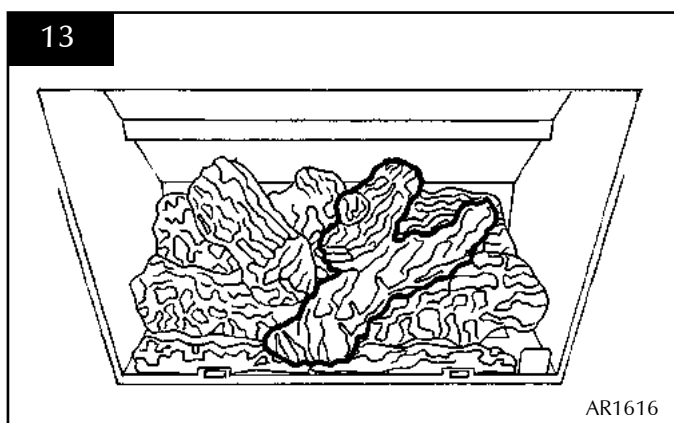

- 6.7
- Manoeuvre the frame under the top edge to secure in place
  - Replace the six screws. Do not overtighten, Diagram 14

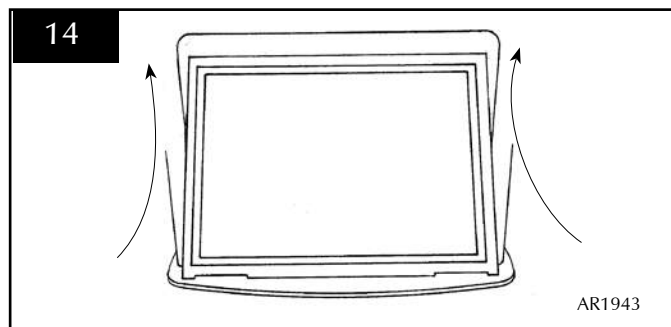

## 6.8 Single Door

- Push the door closed
- Turn the right-hand rosette until the catch holds the door firm

## Double Door

- Push the door closed
- Turn the knob on the right door until the catch holds the door closed

**NEVER OPERATE THE STOVE WHEN THE DOOR IS REMOVED OR WHEN THE GLASS IS BROKEN.**

## 7. GAZCO FLUE SURE SYSTEM

The stove is fitted with the Gazco Flue Sure System, which cuts off the gas supply to the burner if the flue does not operate correctly. This means there is insufficient flue pull. If this happens, wait 10 minutes before trying to relight. Repeated shutdown may indicate a serious problem with the flue system and you must ask a qualified gas engineer to inspect the system. **Do not use the stove until an engineer says it is safe to do so.**

## 8. THE FLAME FAILURE DEVICE

This is a safety feature incorporated in all Yeoman fires to automatically switch off the gas supply if the pilot light goes out and fails to heat the thermocouple.

## 9. 'RUNNING IN'

The surface coating on your Yeoman stove 'burns off' during the first 24 hours of operation on high, producing a harmless and temporary odour. If the odour persists ask your retailer for advice.

# USER INSTRUCTIONS

## 10. SERVICING

A qualified gas engineer must service the stove every 12 months. In all correspondence, always quote the stove type and the Serial Number found on the data badge on the stove.

## 11. VENTILATION

Any purpose provided ventilation should be checked periodically to ensure it is free from obstruction.

## 12. INSTALLATION DETAILS

To assist in any future correspondence, your installer should have completed the Appliance Commissioning Checklist in this manual. This records the essential installation details of this stove. In all correspondence always quote the Model No. and Serial No.

## 13. HOT SURFACES

Parts of this stove become hot during normal use. It is recommended that a suitable fire guard be used for protection of young children and the infirm. Indeed, all parts of the stove should be treated as a 'working surface' except for the control area.



# INSTALLATION INSTRUCTIONS

## TECHNICAL SPECIFICATION

Covering the following models:

YM - N5101CFLUC

YM - N5102CFLUC

YM - P5101CFLUC

YM - P5102CFLUC

Model CAT.	Gas	Gas Type	Working Pressure	NOX Class	Aeration	Injector	Gas Rate m <sup>3</sup> /h	Input kW (Gross)		Country
								High	Low	
Dartmoor: YM-N5101CFLUC YM-N5102CFLUC	I <sub>2</sub> H	Natural Gas G20	20 mbar	3	ø14.5	375	0.634	6.6 Gross	3.2 Gross	GB,IE
Dartmoor: YM-P5101CFLUC YM-P5102CFLUC	I <sub>3</sub> P	LPG Propane G31 LPG Propane G30	37 mbar 29 mbar	3	ø11.5 ø14.5	165	0.222 0.169	6 Gross	3.2 Gross	GB,IE
Efficiency Class II Flue Outlet Size 127 mm (5") ø Gas Inlet Connection Size 8 mm ø										
Minimum flue specification T260/N2/O/D/1										
Maximum flue temperature 180°C										

### Packing Checklist

#### Qty Description

- 1 Stove
- 1 Flue Blanking plate
- 1 Flue In fill plate
- 1 Log set\*
- 1 Fixing kit containing:
  - 1 Instruction Manual

\*Packed in stove

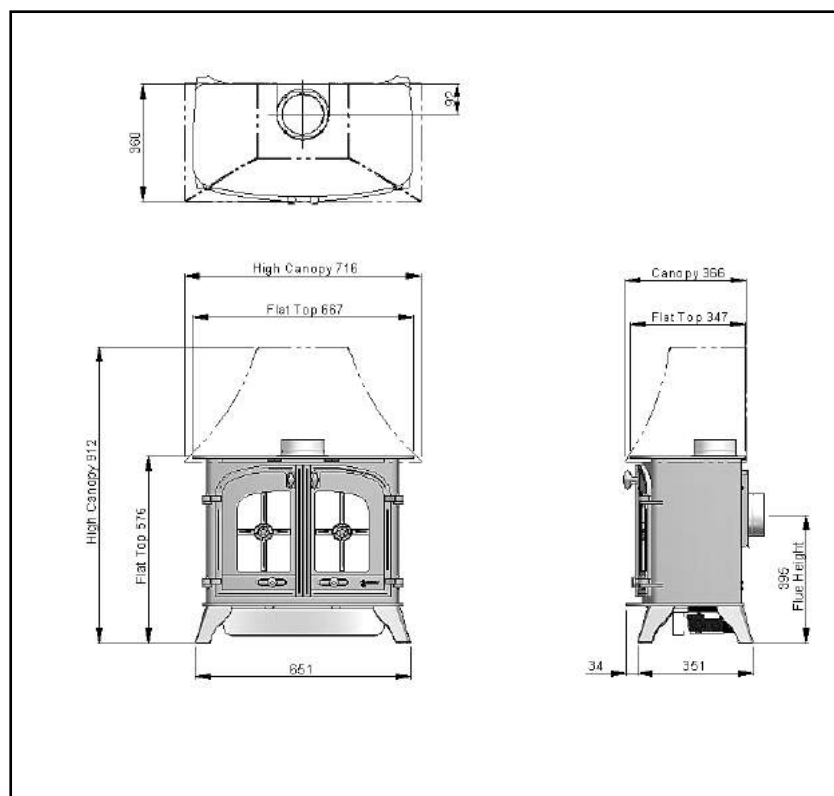

# INSTALLATION INSTRUCTIONS

## SITE REQUIREMENTS

### 1. FLUE AND CHIMNEY REQUIREMENTS

**The flue must be installed in accordance with all local and national regulations and the current rules in force.**

- 1.1 The chimney or flue system must be a minimum of 127mm in diameter. (5").
- 1.2 The minimum height of the flue or chimney must be 3 metres (10ft). Any horizontal flue run from the rear outlet must not exceed 100mm from the back of the stove.
- 1.3 The chimney or flue must be free from any obstruction. Any damper plates should be removed or secured in the fully open position, and no restrictor plates should be fitted.
- 1.4 The chimney should be swept immediately prior to the installation of the stove - unless you can see it is clean and there are no obstructions throughout its entire length.
- 1.5 If it is intended to fit the stove into a existing brick built chimney, a 5" (127mm) liner must be used. Larger lined flues may work, but in some instances could cause cold start flue problems resulting in nuisance shutdown. Lined flues above 7" (175mm) are not recommended.
- 1.6 Due to recent changes to European chimney standards, new flue's and chimney's are now described by their temperature, pressure and resistance to corrosion, condensation and fire. To assist in identifying the correct flue system, the minimum flue specification is shown in the technical specification on page 9 of this book. Existing chimney's are not covered by this system.

### 2. VENTILATION

- 2.1 This stove has a rated output below 7kW and does not normally require any additional ventilation.

### 3. INSTALLATION OF THE GAS SUPPLY

**This appliance is intended for use on a gas installation with a governed meter.**

- 3.1 Before installation, ensure the local distribution conditions (identification of the type of gas and pressure) and the adjustment of the stove are compatible.
- 3.2 Ensure that the gas supply is capable of delivering the required amount of gas, and is in accordance with the rules in force.
- 3.3 Soft copper tubing and soft soldered joints can be used but must not be closer than 50mm to the base of the tray.
- 3.4 An independent means of isolating the gas pipe must be provided before the gas supply enters the stove.
- 3.5 Before connecting to the stove all supply gas pipes must be purged of any debris.

### 4. STOVE LOCATION

- 4.1 This stove must stand on a non-combustible hearth that is at least 12mm thick, and projects 50mm minimum from the base of the stove in all directions, Diagram 1.

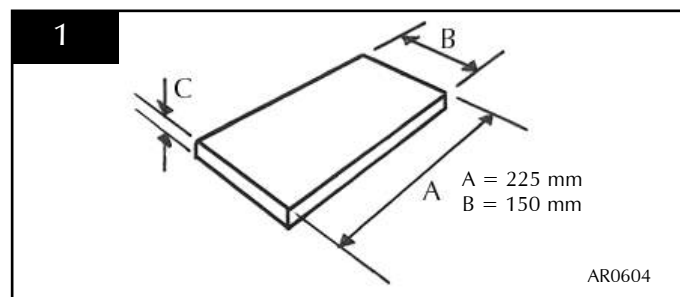

- 4.2 Do not install in a room that contains a bath or shower.

#### MINIMUM CLEARANCE

- 4.3 There must be NO combustible materials within the minimum clearance measurements shown in Diagrams 2 and 2A.

These dimensions give adequate space at the side and rear to reach the controls.

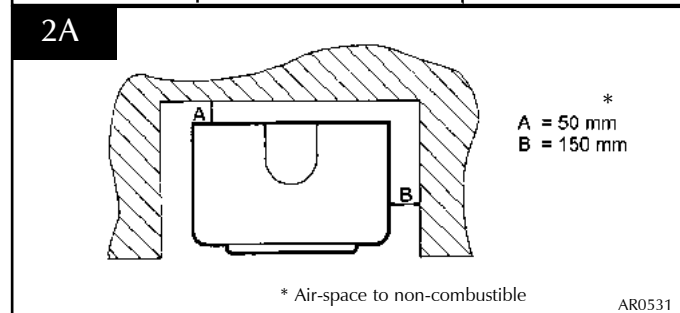
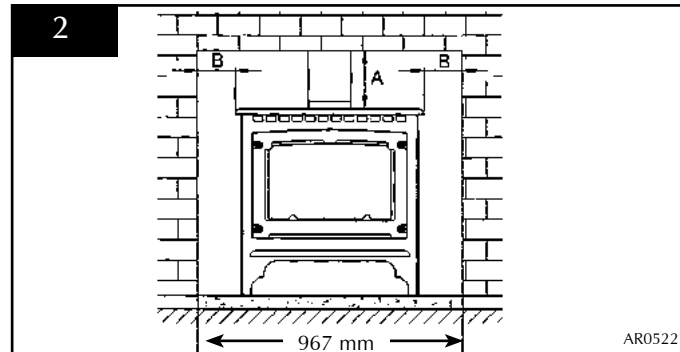

**IMPORTANT: ENSURE THAT THE STOVE IS CORRECTLY ADJUSTED FOR THE GAS TYPE AND CATEGORY APPLICABLE IN THE COUNTRY OF USE. REFER TO DATABADGE AND TECHNICAL SPECIFICATIONS OF THIS BOOKLET.**

**FOR DETAILS OF CHANGING BETWEEN GAS TYPES REFER TO *SERVICING INSTRUCTIONS, REPLACING PARTS.***

# INSTALLATION INSTRUCTIONS

## INSTALLATION

### 1. CONTROL UPGRADE

1.1 Your stove is fitted with a control valve that can be upgraded to battery powered Remote Control. This upgrade can be fitted by anyone capable of simple DIY jobs. Your Yeoman dealer keeps two versions of the remote:

1.2 **STANDARD REMOTE CONTROL (Yeoman PART NUMBER YM-8455)**

This remote controls the gas stove after the pilot has been lit to:

- turn on the main burner
- regulate the flame from low to high and back
- turn off the burner leaving just the pilot burning

1.3 **THERMOSTATIC AND TIMER REMOTE CONTROL (Yeoman PART NUMBER YM-8456)**

This remote controls the gas stove after the pilot has been lit. In 'MANUAL MODE' you can:

- turn on the main burner
- regulate the flame from low to high and back
- turn off the burner leaving just the pilot burning

In 'AUTO MODE' you can:

- set the room temperature so the stove automatically maintains that temperature

In 'TIMER MODE' the stove:

- turns on and off according to the set time periods
- automatically regulates the room temperature during the set periods

### 2. SAFETY PRECAUTIONS

2.1 For your own and other's safety, you must install this stove according to local and national codes of practice. Failure to install the stove correctly could lead to prosecution:

- Read these instructions before installing and using this stove.

2.2 All the instructions must be left intact with the user.

2.3 Make sure you install the stove in a sufficiently ventilated space.

2.4 This stove is intended for use on a governed gas installation and set to the required pressure.

2.5 Keep all plastic bags away from young children.

2.6 Do not place any object on or near the stove and allow adequate clearance above the stove. See Diagram 2 and 2A, Site Requirements.

2.7 The stove is fitted with the Gazco Flue Sure System which cuts off the gas supply to the burner if the flue does not operate correctly. This means there may be insufficient flue pull. If this happens, wait 10 before trying to relight.

Repeated shutdown may indicate a serious problem. You must investigate both the flue and the Flue Sure device - refer to *Servicing Instructions, Replacing Parts, Section 3*.

### 3. INSTALLATION OF THE STOVE

#### Flue Pipe Installation

- 3.1
- Unpack the accessories carton and stove unit
  - Decide upon top or rear flue exit. The stove is factory built for rear flue exit, but it can be changed to top exit by:
    - 3.1.1 - Removing the flue spigot from the rear of the stove
      - Replacing it with the blanking plate from the top of the stove
      - Put the flue spigot on the top of the stove
- 3.2
- Position the stove observing all clearance measurements
  - Adjust the balance of the stove using the bolts in the legs to make it level

#### Canopy Fitting

3.3 **To fit the canopy to the top of the stove:**

- Slide the canopy over the top plate, Diagram 1

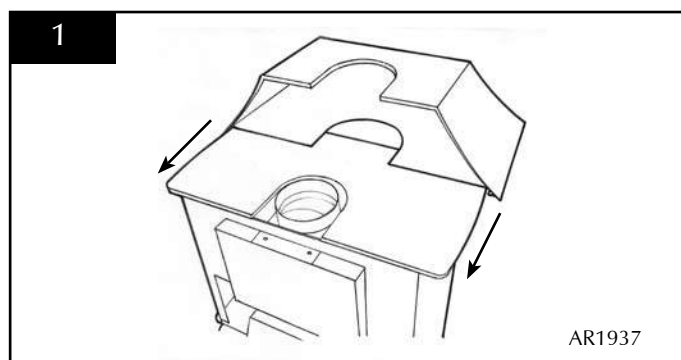

- Make sure the canopy fits into the guide along the bottom of the canopy, Diagram 2

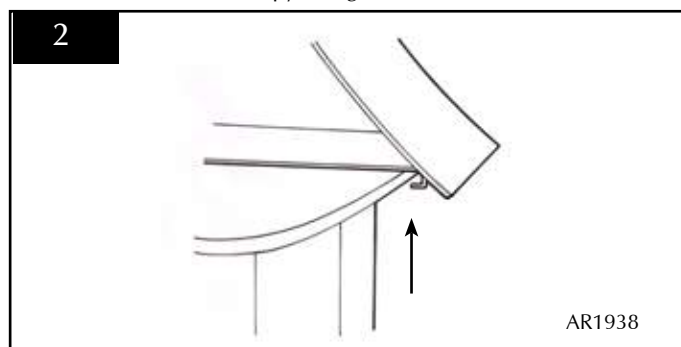

- Push the canopy back until it hits the stop
- Make sure the canopy sits square on top of the stove

### 4. GAS SUPPLY

- 4.4
- Run the gas supply to the stove and **PURGE THE SUPPLY PIPE** This is essential to expel any debris that may block the gas controls.

# INSTALLATION INSTRUCTIONS

## INSTALLATION

- Connect the gas supply to the 8mm-compression elbow at the right-hand rear corner of the stove
- Check the gas soundness up to the gas inlet connection
- Check the pull of the flue system by applying a lighted smoke pellet to the flue system opening. If there is a definite flow into the chimney, carry on with the installation. If not, repeat after warming the chimney for a few minutes.

**IF THERE IS STILL NO DEFINITE FLOW, THE FLUE MAY REQUIRE ATTENTION - SEEK EXPERT ADVICE**

- 4.5 The flue system can now be connected to the stove:
- Make sure all joints are sealed with a suitable fire resistant sealant. We advise you to use a physical retention method at the flue spigot joint using self-tapping screws.
- 4.6
- Connect a suitable pressure gauge to the test point on the inlet fitting and turn on the gas
  - Light the stove and check all gas joints for gas soundness
  - Turn the stove to maximum and check the supply pressure is as stated on the databadge
  - Turn off the gas and replace the test point screw
  - Turn on the gas and check the test point for gas soundness

### Advice on Handling and disposal of fire ceramics

The fuel effect and side panels in this appliance are made from Refractory Ceramic Fibre (RCF), a material which is commonly used for this application.

Protective clothing is not required when handling these articles, but we recommend you follow normal hygiene rules of not smoking, eating or drinking in the work area and always wash your hands before eating or drinking.

To ensure that the release of RCF fibres are kept to a minimum, during installation and servicing a HEPA filtered vacuum is recommended to remove any dust accumulated in and around the appliance before and after working on it. When servicing the appliance it is recommended that the replaced items are not broken up, but are sealed within heavy duty polythene bags and labelled as RCF waste.

RCF waste is classed as stable, non-reactive hazardous waste and may be disposed of at a licensed landfill site.

Excessive exposure to these materials may cause temporary irritation to eyes, skin and respiratory tract; wash hands thoroughly after handling the material.

## 5. FUEL BED ARRANGEMENT

### Single Door

To open the door and access the interior:

- Turn the right-hand rosette, Diagram 4
- Pull the door open

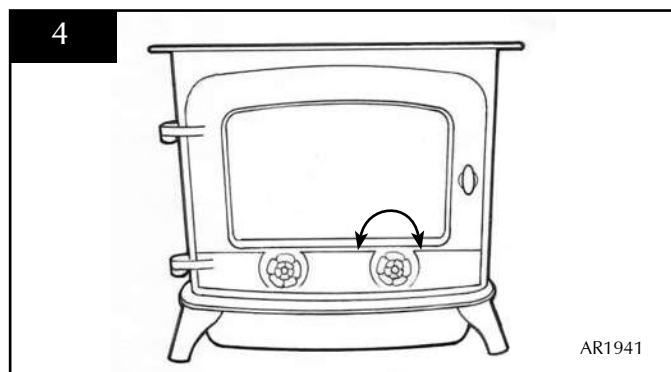

### Double Door

To open the door:

- Turn the knob on the right door to release the catch, Diagram 5

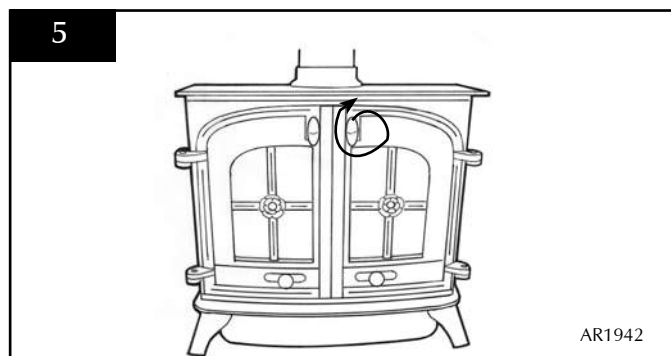

- Remove the glass frame by undoing the six screws, Diagram 6

# INSTALLATION INSTRUCTIONS

## INSTALLATION

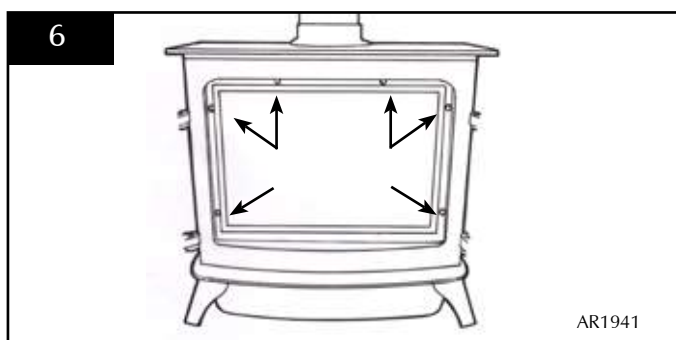

- Lower the frame down to clear the top edge before lifting clear

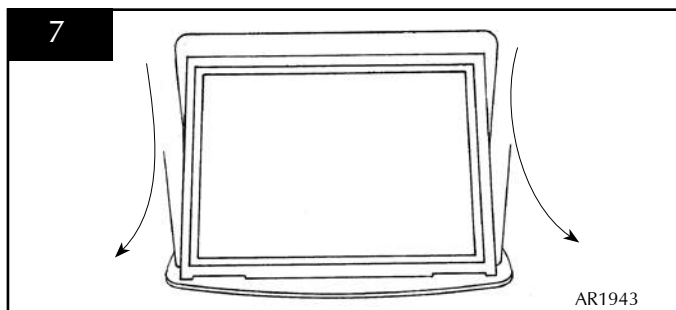

The fuel bed consists of 5 logs and 2 ash panels. The logs have letters A,B,C,D and E moulded into them for identification.

- 5.1
- Take the rear log A
  - Place it up against the rear of the fire sitting on the two flat ledges of the burner. The two legs of the log should sit between the rear burner ports, Diagram 8
  - Ensure there is an equal gap between the sides of the firebox at each end of the log

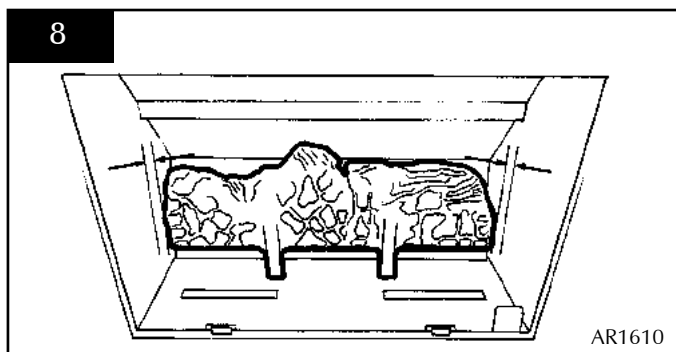

- 5.2
- Place log B on the left-hand side of the burner with the location bar on its underside slid into the long slot of the burner
  - Make sure the log is as far to the left as possible, Diagram 9

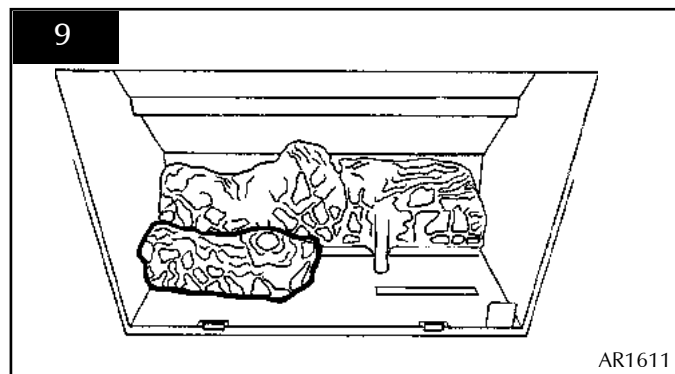

- 5.3
- Place log C on the right-hand side of the burner with the location bar on its underside slid into the long slot of the burner.
  - Make sure the log is as far right as possible, Diagram 10

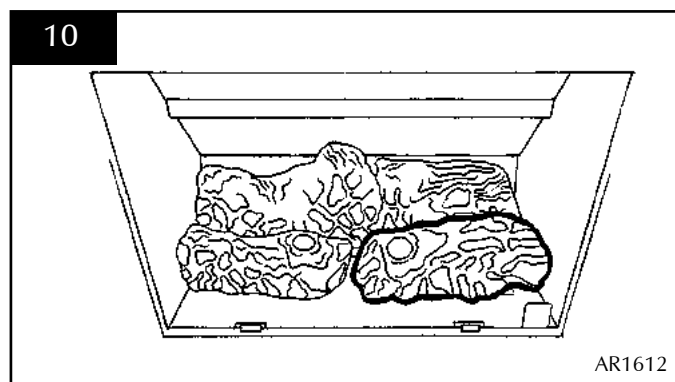

- 5.4
- Place log D across from the rear log A to log B on the left-hand side. There are cut-outs in both logs for location. See Diagram 11

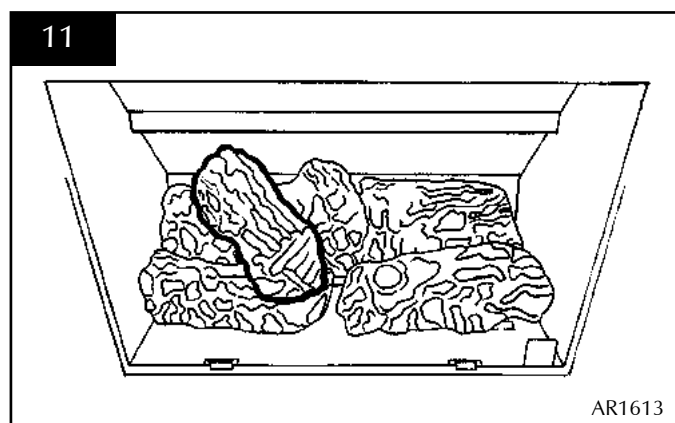

- 5.5
- There are two ash panels to lie across the front of the burner:
- Place the panel with the flat edge facing the left side of the firebox. There are location holes on this log fitting the screw holes on the burner.

# INSTALLATION INSTRUCTIONS

## INSTALLATION

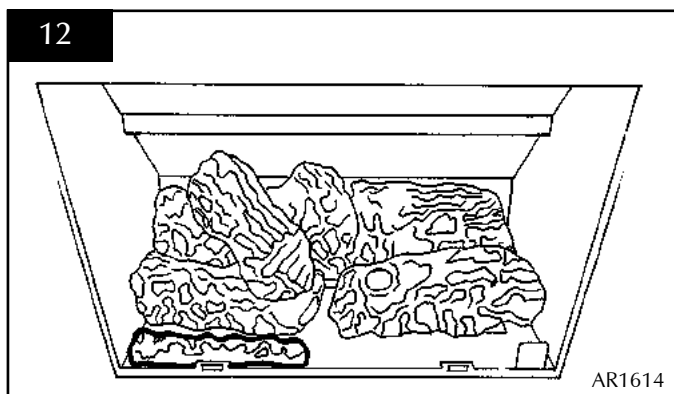

- Place the second ash panel to the right of the first, the pointed end of this panel fitting the V shape and fitting the screw holes on the burner.
- Ensure that both logs are horizontal to the burner ports.

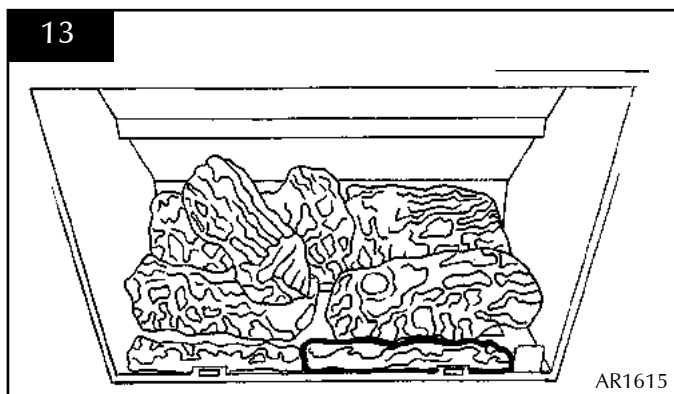

- 5.6
- Place log E across from the rear of log A to log C on the right-hand side using the shaped cut-outs as location guides. The front of the log should sit on the front ash panels and should fit tight to log C. See Diagram 14

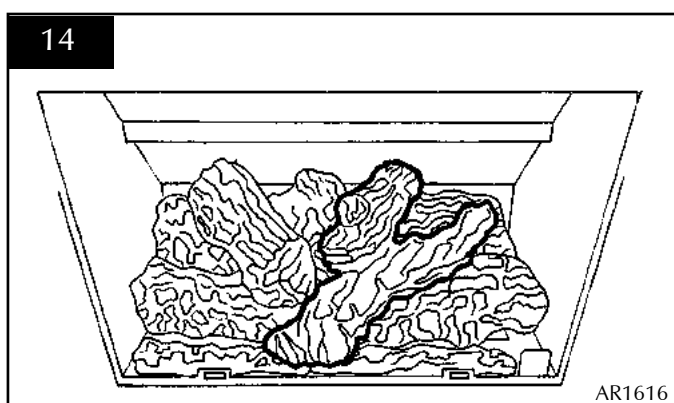

- 5.7
- Manoeuvre the frame under the top edge to secure in place
  - Replace the six screws. Do not overtighten, Diagram 15

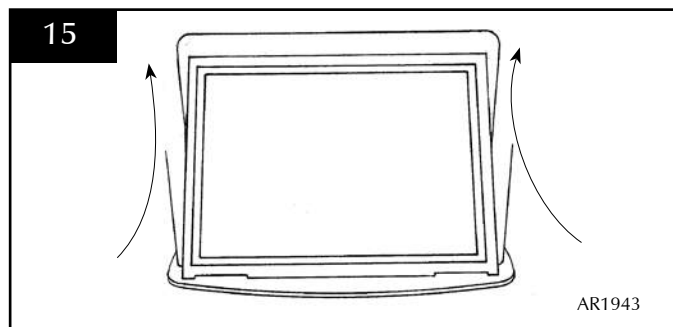

5.8 **Single Door**

- Push the door closed
- Turn the right-hand rosette until the catch holds the door firm

**Double Door**

- Push the door closed
- Turn the knob on the right door until the catch holds the door closed

**NEVER OPERATE THE STOVE WHEN THE DOOR IS REMOVED OR WHEN THE GLASS IS BROKEN.**

## 6. LIGHTING

- 6.1 Full instructions are given in the *User Instructions* under *Lighting the Stove*.

# INSTALLATION INSTRUCTIONS

## COMMISSIONING

### 1. COMMISSIONING

- 1.1
- Close all doors and windows in the room
  - Light the stove and leave for maximum for 10 minutes •
  - Position a lighted smoke match just inside the draught diverter opening
  - Check all smoke is drawn into the opening,, Diagram 1
- If there is any doubt, run the stove for a further 10 minutes, and repeat the test.

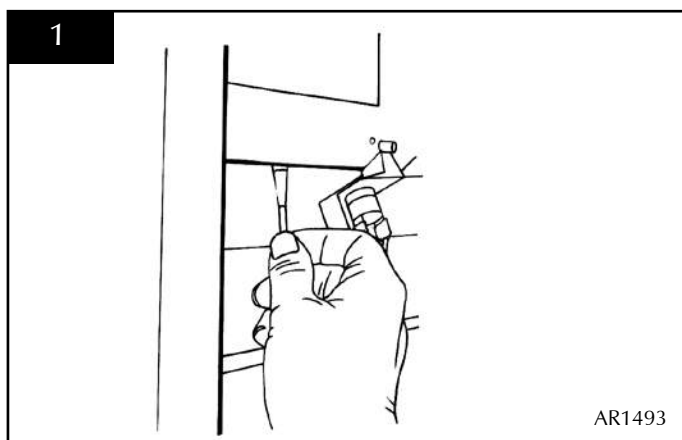

- 1.2
- If there are any extractor fans in adjacent rooms:
- Repeat the test with the fans running on maximum and interconnecting doors open

**IF SPILLAGE PERSISTS, DISCONNECT THE STOVE AND SEEK EXPERT ADVICE.**

For future reference record the installation details on the Appliance Commissioning Checklist of these instructions.

# SERVICING INSTRUCTIONS

## SERVICING/FAULT FINDING

### 1. SERVICING REQUIREMENTS

This stove must be serviced at least once a year by a competent person.

All tests must be serviced by best practice as described by the current CORGI recommendations.

Refer to ADVICE ON HANDLING AND DISPOSAL OF FIRE CERAMICS In *Installation Instructions* section 5

- 1.1 Before any tests are undertaken on the stove:
- Conduct a gas soundness test for the property to ensure there are no gas leaks prior to starting work.

- 1.2
- Fully check the operation of the stove

Special checks

1.2.1 Clean any lint or fluff from the pilot - pay particular attention to the aeration hole in the side of the pilot

1.2.2 Clean away any fluff or lint from under the burner

1.2.3 Check the spark gap on the pilot is correct

- Correct any faults found during the initial tests
- Re-commission the stove conducting the usual safety checks

- 1.3 Advise the customer of any remedial action taken.

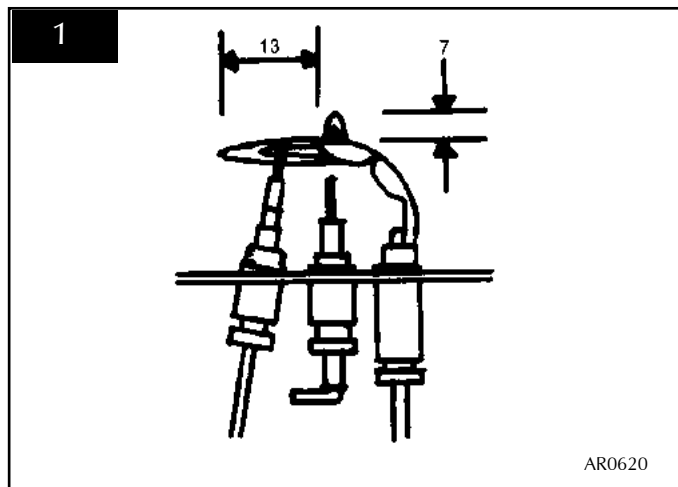

### IGNITION FUNCTIONAL CHECK 1

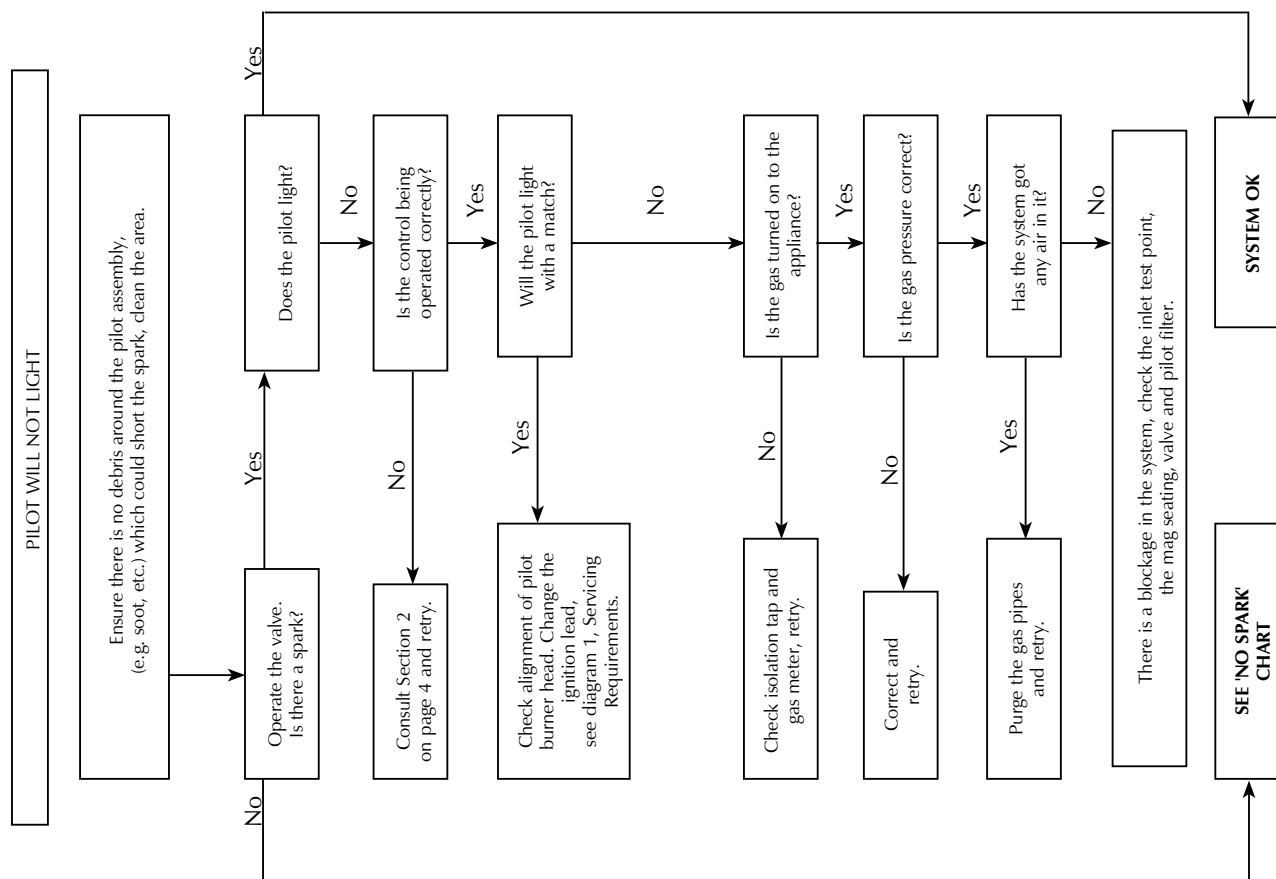



# SERVICING INSTRUCTIONS

## SERVICING/FAULT FINDING

### FLAME FAILURE FUNCTIONAL CHECK

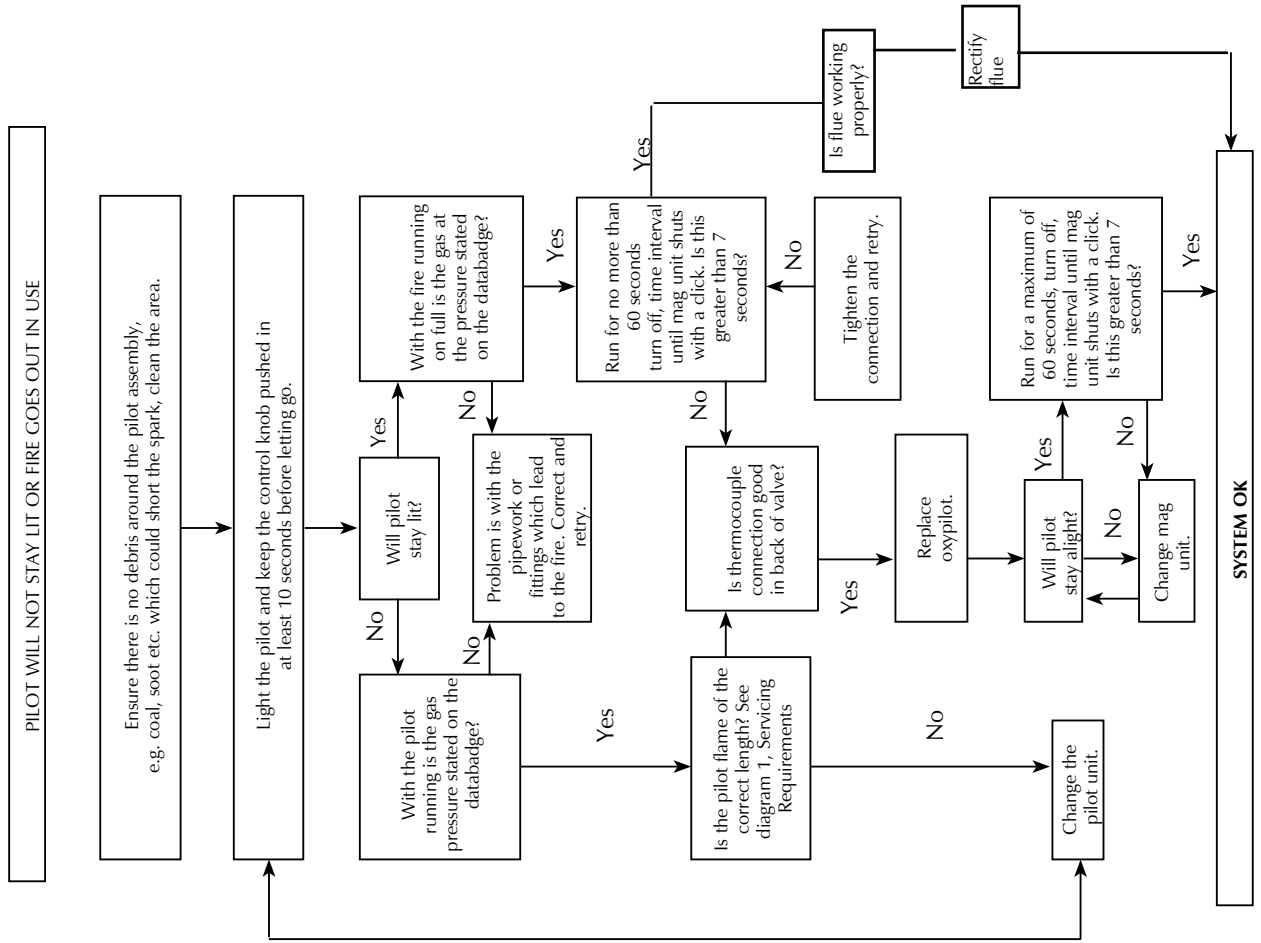

### IGNITION FUNCTIONAL CHECK 2

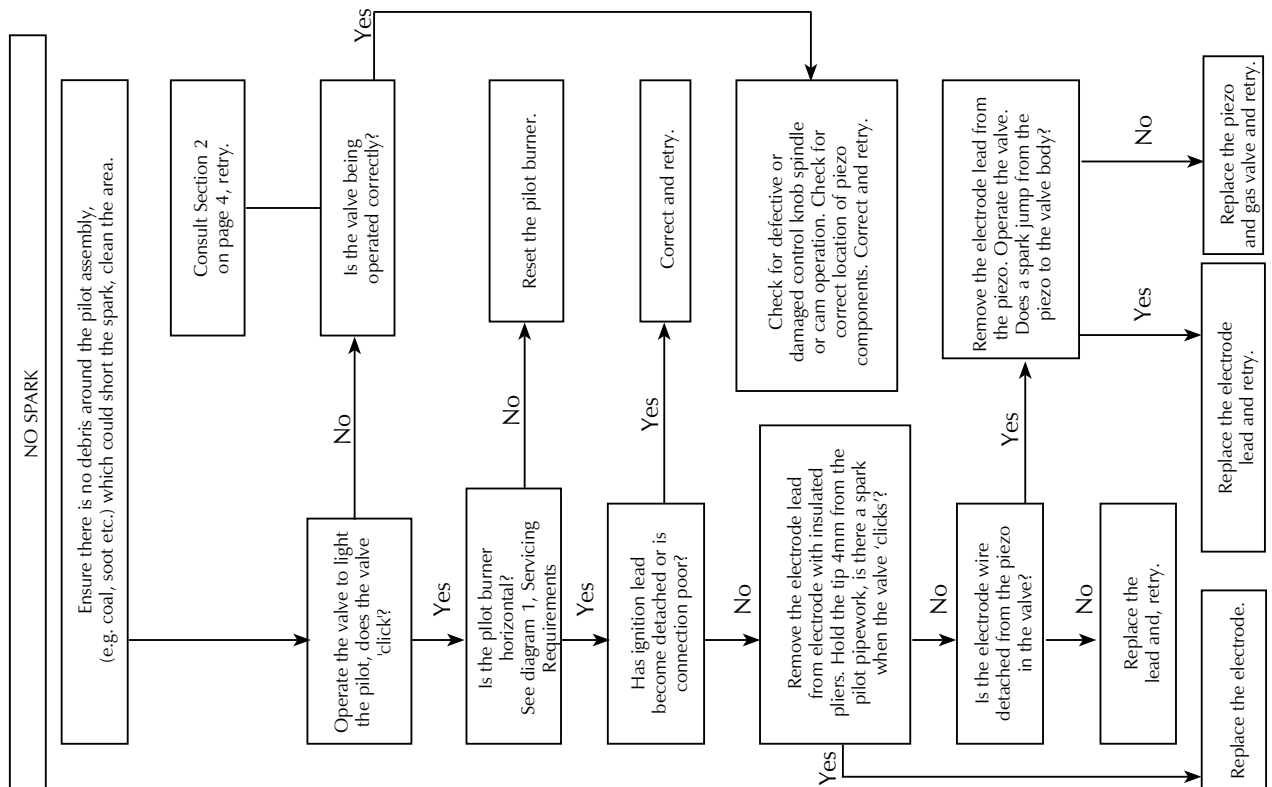

# SERVICING INSTRUCTIONS

## REPLACING PARTS

### 1. GENERAL

- 1.1 All main components can be replaced without removing the stove from its installation. **IT IS ESSENTIAL THAT THE GAS SUPPLY TO THE STOVE IS TURNED OFF AT THE ISOLATION DEVICE BEFORE PROCEEDING FURTHER.**

### 2. MAIN BURNER

- 2.1 Turn the gas supply off at the isolation device. Ensure the unit is cool.
- Remove the door and place to one side
  - Remove the ceramic fuel bed components carefully
  - Remove the three securing screws, two at the rear and one at the front left hand side. See Diagram 1
- The burner venturi is engaged over the injector. When removing the burner make sure you clear the injector to free up the right side of the burner.
- Take care too not to damage the pilot when removing the burner.
- Raise the left-hand side of the burner to clear the bracket and draw forward

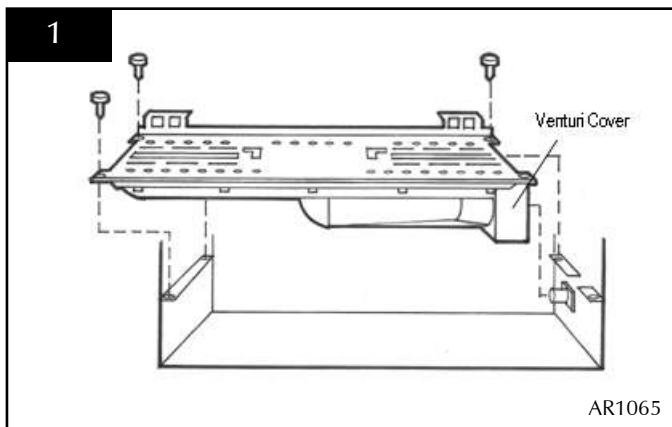

- 2.2 To replace the burner
- Engage the venturi over the injector making sure the burner sits on top of the bracket
  - Push the burner to the right and hold to insert the three screws

**NOTE: BEFORE REPLACING THE BURNER, ENSURE THE SILICONE SEAL AROUND THE INJECTOR IS INTACT AND CHECK THE VENTURI COVER IS ATTACHED.**

### 3. PILOT UNIT

**Do not tamper with the Flue Sure system. Use only genuine Gazco replacement parts when servicing the system.**

The pilot assembly has five components you can change:

- 1) Pilot burner bracket
- 2) Pilot injector
- 3) Electrode
- 4) Thermocouple
- 5) Gasket

- 3.1
- Turn the gas supply off at the isolation device
  - Remove the door and place to one side
  - Remove the ceramic fuel bed components carefully
  - Refer to Section 2 to remove the main burner
  - Remove the thermocouple baffle taking note of how it is positioned in Diagram 2

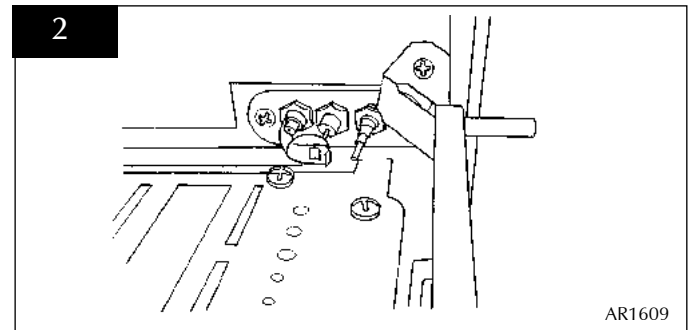

- Remove the two fixing screws from the pilot bracket, Diagram 3.
- Gently draw the assembly out of the firebox to access the nuts and ignition lead

**NOTE: TAKE CARE NOT TO DAMAGE THE GASKET**

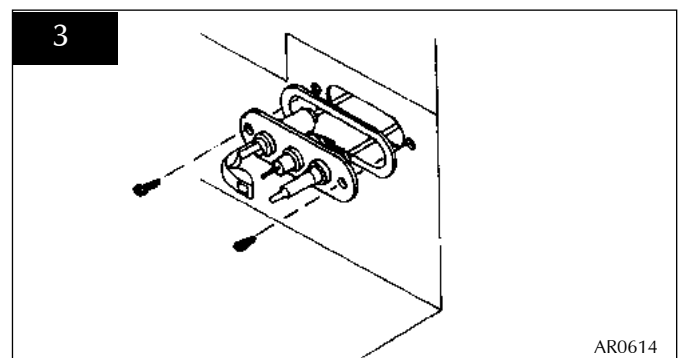

- 3.2 To remove the pilot injector:
- Undo the compression nut on the pilot feed pipe and withdraw the injector which is hooked onto the olive.
- When replacing an injector always make sure it is hooked onto the olive before inserting it into the pilot burner. See Diagram 4.

# SERVICING INSTRUCTIONS

## REPLACING PARTS

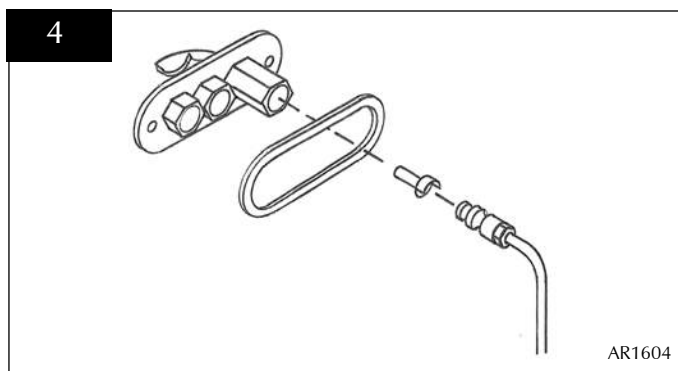

- 3.3 To remove the electrode:
- Disconnect the ignition lead and undo the retaining nut. The electrode can now be removed. Note the orientation of the electrode terminal when reassembling. See Diagram 5.

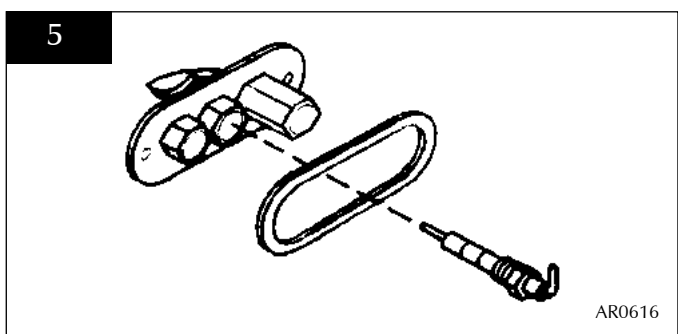

- 3.4 To remove the thermocouple:
- Undo the retaining nut and withdraw the thermocouple, Diagram 6

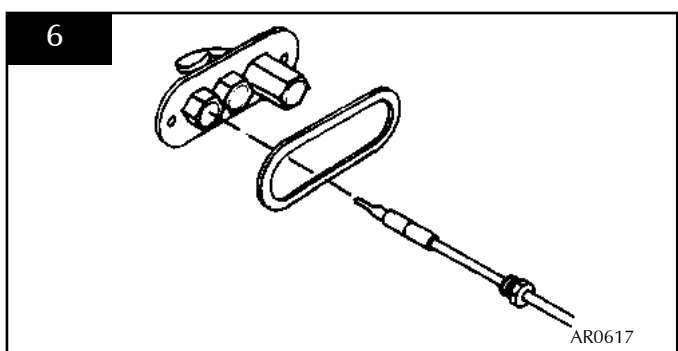

- Undo the thermocouple from the back of the gas valve, Diagram 7, arrow A
- Reassemble in reverse order
- Do not overtighten

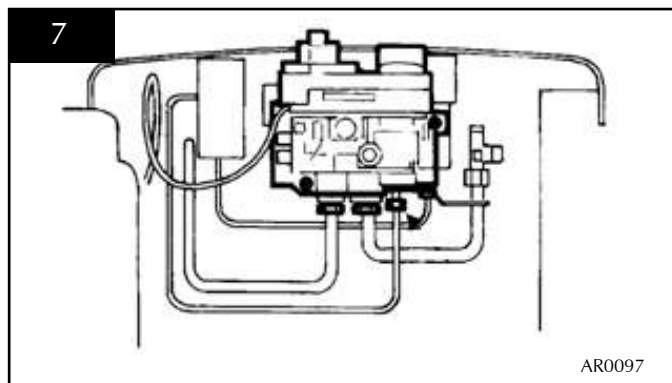

**NOTE: TAKE CARE NOT TO DISCONNECT THE SENSOR WIRES FOR THE GAZCO FLUE SURE SYSTEM WHEN YOU REPLACE THE THERMOCOUPLE TO THE BACK OF THE GAS VALVE.**

### 4. IGNITION LEAD

- 4.1 Look at Section 3 above to access the back of the pilot assembly:
- Disconnect the ignition lead from the electrode
  - Undo the single screw that secures the left side of the control cover, Diagram 8.

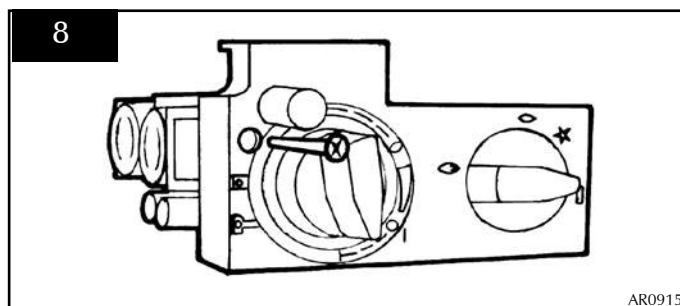

To release the right side of the control cover:

- Insert the narrow blade screwdriver into the slot shown in Diagram 9
- Lever it gently and pull from the right-hand side at the same time to remove the cover.

There is a small cylindrical metal spacer inside the cover. This must be kept and replaced on the fixing screw during re-assembly.

# SERVICING INSTRUCTIONS

## REPLACING PARTS

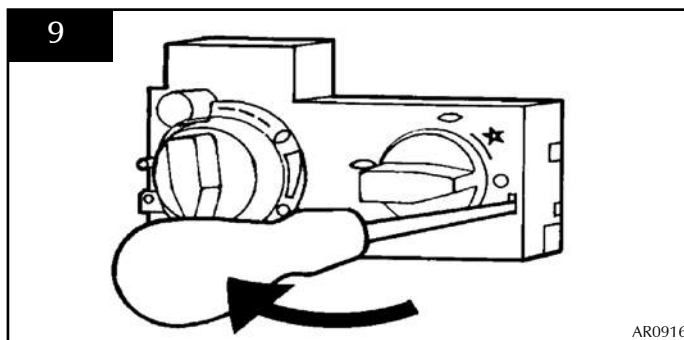

- Disconnect the other end of the ignition lead from the valve body

**Note the existing route of the ignition lead.**

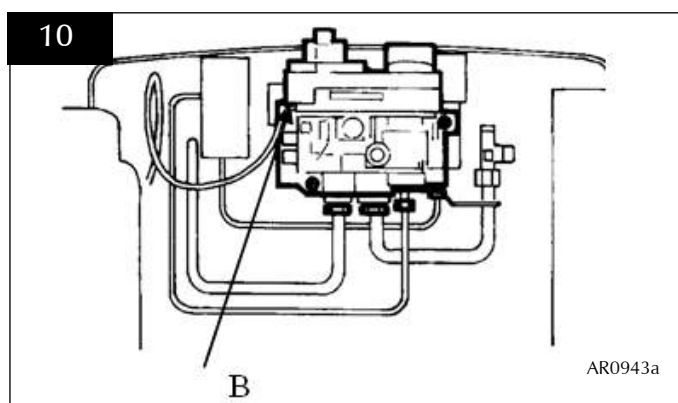

- 4.2 • Replace with a new ignition lead following the same route as the old one
- Replace the valve cover and the pilot assembly
- 4.3 • Check operation of the new ignition lead

### 5. PIEZO

- 5.1 The piezo assembly used on this appliance is not serviceable and is unlikely to fail.
- 5.2 If a new piezo is required, you must change the gas valve. Refer to Section 6.

### 6. GAS VALVE

- 6.1 • Turn off the gas supply at the isolation device
- Disconnect the 2 x 8mm and 1 x 4mm gas pipe fittings at the back of the gas valve
- Disconnect the thermocouple, see Diagram 11

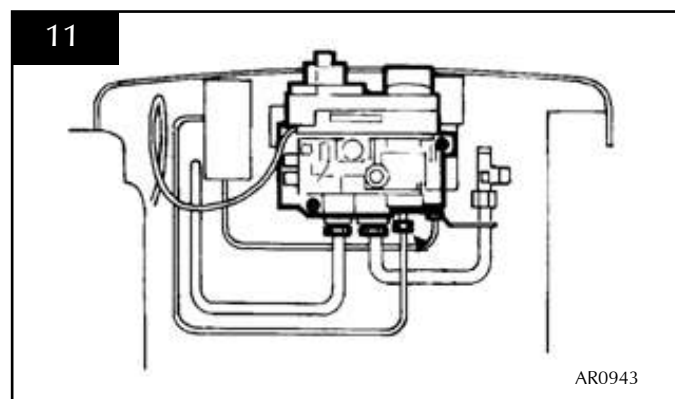

- Undo the single screw that secures the left-hand side of the control cover, Diagram 12

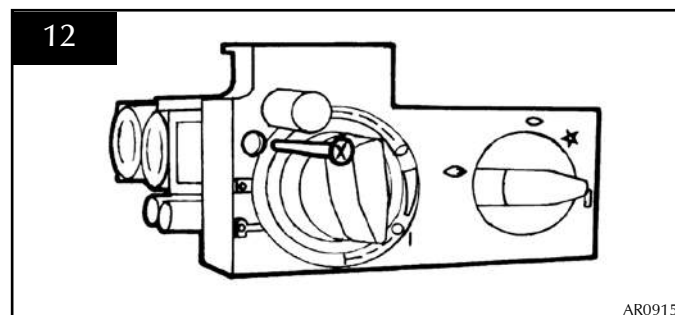

- 6.2 To release the right side of the cover:
  - Insert the narrow blade screwdriver into the slot shown in Diagram 13
  - Lever it gently and pull from the right-hand side at the same time to remove the cover. There is a small cylindrical metal spacer inside the cover. This must be kept and replaced on the fixing screw during re-assembly.

# SERVICING INSTRUCTIONS

## REPLACING PARTS

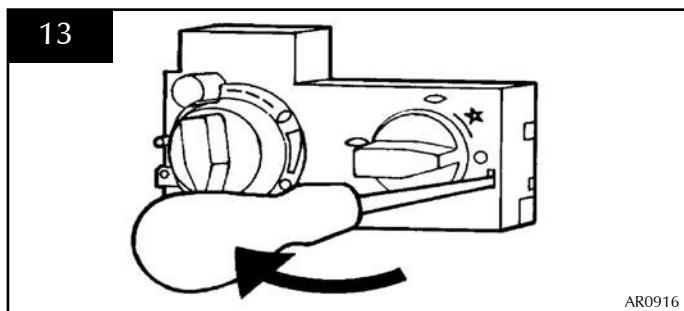

### NOTE THE EXISTING ROUTE OF THE IGNITION LEAD

- 6.3
- Disconnect the ignition lead from the gas valve
  - Undo the two bolts securing the gas valve to the stove and remove the valve
- 6.4
- Replace in reverse order
  - Check all joints for gas leaks
  - Check operation of the thermocouple and ignition lead.

## 7. MAGNETIC SAFETY VALVE

- 7.1
- Turn off the gas supply at the isolation device
  - Undo the thermocouple connection from the back of the gas valve
  - Pull the sensor leads clear and remove the interrupter block
  - Undo the magnetic valve-retaining nut from the back of the control valve
  - Gently tap out the magnetic valve and replace with a new unit
  - Replace the retaining nut and tighten, Diagram 14

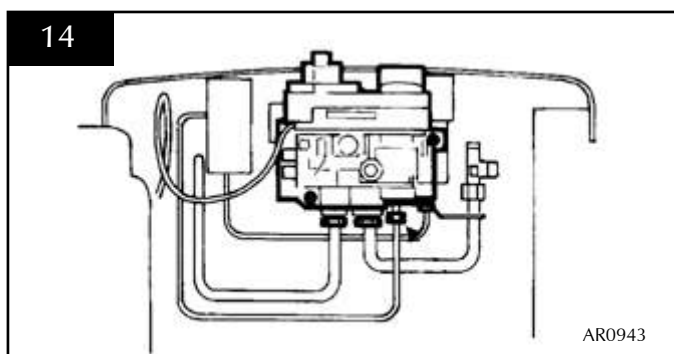

- 7.2
- Reassemble the interrupter block and leads
  - Secure the thermocouple connection at the rear of the gas control (Do not overtighten)

- Turn on the gas supply
- Check the entire pipework and valve joints for any leaks

## 8. MAIN INJECTOR

- 8.1
- Turn off the gas at the isolation device. Refer to *Section 2, Replacing Parts* to remove the main burner
- 8.2
- Undo the compression nut from the feed pipe at the gas control under the appliance
- 8.3
- Working from inside the firebox:
- Remove the lock nut from the injector, Diagram 15
  - Withdraw the injector complete with the feed pipe from under the appliance

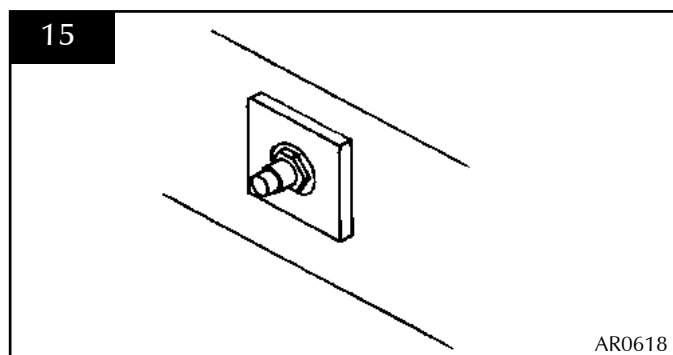

- 8.4
- Holding the injector with a spanner to undo the feed pipe

### NOTE: THE ORIENTATION OF THE INJECTOR.

- 8.5
- Reassemble in reverse order
  - Turn on the gas supply and check for any leaks

## 9. GAZCO FLUE SURE SYSTEM

- 9.1
- Remove ceramic components and place to one side
  - Remove the burner casting by removing the three screws located on the sides of the burner skin.

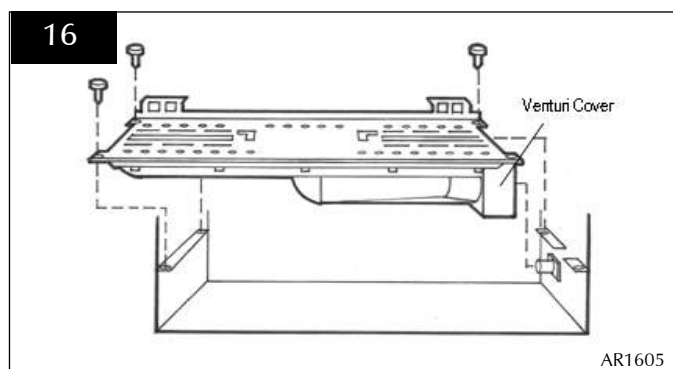

- 9.2
- Remove the screw on the back panel and remove the panel. Refer to Diagram 17

# SERVICING INSTRUCTIONS

## REPLACING PARTS

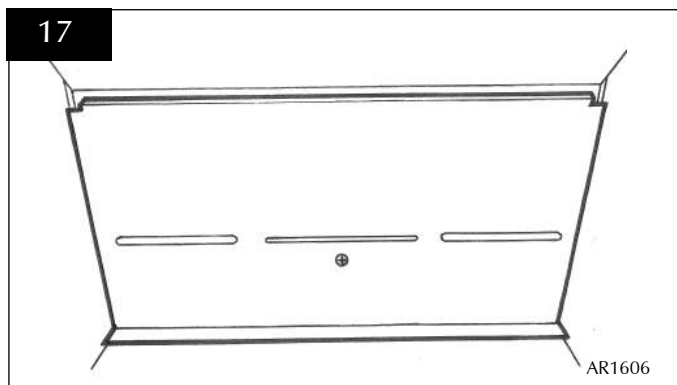

- 9.3 • Undo the two screws at the back of the firebox and carefully withdraw the bracket

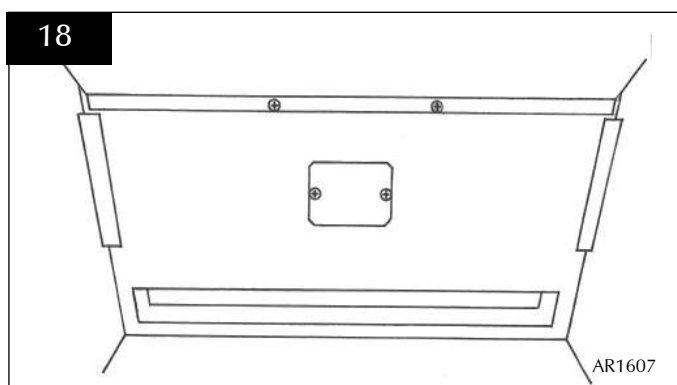

- 9.4 Disconnect the two slender wires. Undo the two tapite screws and remove the sensor and the two plastic spacers. See Diagram 19.

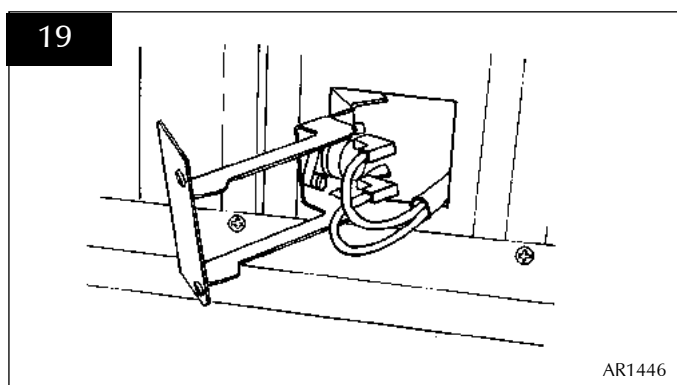

- 9.5 • Refit the new sensor, ensuring that the plastic spacers are between the sensor and the bracket. Refit the leads. See Diagram 20

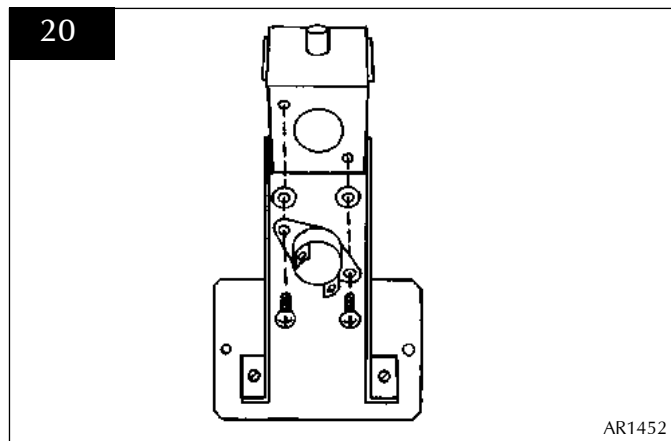

- 9.6 • Feed the cable back through the hole as you replace the bracket. When the bracket is located correctly it sits flush with the back panel with no force. If not positioned correctly the bracket sits at an angle, Diagram 21.

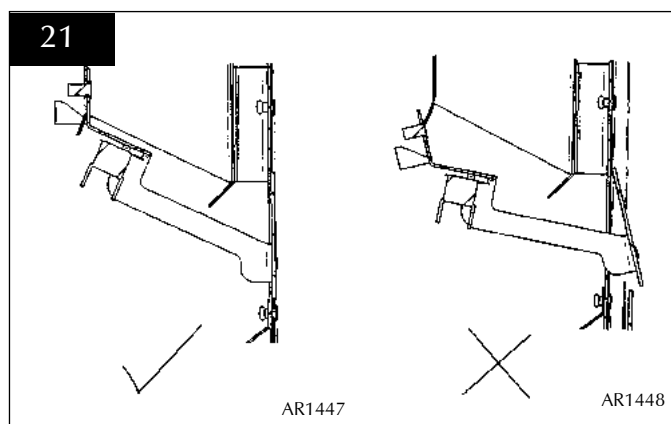

### 10. PRIMARY AERATION PLATE

- 10.1 • Turn the gas supply off at the isolation device  
 • Refer to Section 2 to remove the main burner  
 • Remove the two screws on the burner skin to detach the cover from the venturi  
 • Slide the venturi cover off the venturi as in Diagram 22

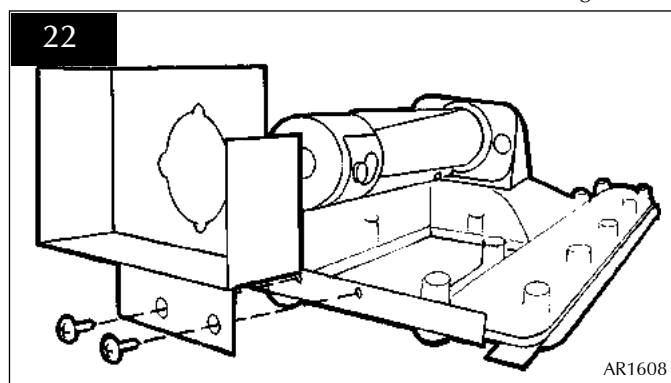

# SERVICING INSTRUCTIONS

## REPLACING PARTS

- Change the aeration plates to those stated in the technical specification for the gas for this product
- Refer to the databadge

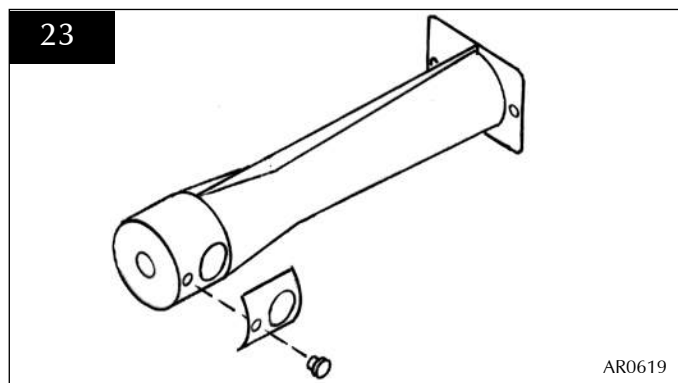

- 10.2 • Reassemble in reverse order with correct aeration plate(s).

**NOTE: EVEN IF NO AERATION PLATE IS REQUIRED, THE SMALL SCREW(S) MUST BE REPLACED**

### 11. CHANGING BETWEEN GAS TYPES

- 11.1 In order to change between gas types, it will be necessary to change the following items.

- Pilot Unit
- Control Valve
- Main Injector
- Aeration Plate (if required)
- Databadge

The relevant parts can be ordered as a conventional kit from Yeoman. Always quote the appliance type and serial number when ordering spare parts.

**\*\* NOTE: THE CONTROL VALVE IS FACTORY PRESET FOR CORRECT GAS TYPE AND MODEL. A NEW UNIT WILL NEED TO BE ORDERED WHEN CHANGING BETWEEN GAS TYPES.**

### 12. CONTROL UPGRADE

See *Installation*, section 1.

### 13. SHORT SPARES LIST

Component	NG	LPG	
	G20	G30	G31
	20mb	29mb	37mb
Main Injector	IN0045	IN0030	IN0030
Aeration plate	N/A	N/A	GZ5387
Pilot injector	PI0026	PI0015	
Burner assembly	GZ5369	GZ5388	
Thermocouple	PI0010		
Magnetic unit	GC0092		
Electrode	PI0053		
Pilot Gasket	PI0052		
Gas valve	GC0088K		
Ignition lead	GC0090		
Complete log set	CEO583		
TTB	EL0001		
TTB Lead	EL0064		
Interrupter block	GC0026		
Standard upgrade kit	YM-8455		
Thermostat/timer kit	YM-8456		

# SERVICE RECORDS

## 1ST SERVICE

Date of Service:.....  
Next Service Due:.....  
Signed:.....  
Dealer's Stamp/CORGI Registration Number

## 2ND SERVICE

Date of Service:.....  
Next Service Due:.....  
Signed:.....  
Dealer's Stamp/CORGI Registration Number

## 3RD SERVICE

Date of Service:.....  
Next Service Due:.....  
Signed:.....  
Dealer's Stamp/CORGI Registration Number

## 4TH SERVICE

Date of Service:.....  
Next Service Due:.....  
Signed:.....  
Dealer's Stamp/CORGI Registration Number

## 5TH SERVICE

Date of Service:.....  
Next Service Due:.....  
Signed:.....  
Dealer's Stamp/CORGI Registration Number

## 6TH SERVICE

Date of Service:.....  
Next Service Due:.....  
Signed:.....  
Dealer's Stamp/CORGI Registration Number

## 7TH SERVICE

Date of Service:.....  
Next Service Due:.....  
Signed:.....  
Dealer's Stamp/CORGI Registration Number

## 8TH SERVICE

Date of Service:.....  
Next Due:.....  
Signed:.....  
Dealer's Stamp/CORGI Registration Number

## 9TH SERVICE

Date of Service:.....  
Next Due:.....  
Signed:.....  
Dealer's Stamp/CORGI Registration Number

## 10TH SERVICE

Date of Service:.....  
Next Service Due:.....  
Signed:.....  
Dealer's Stamp/CORGI Registration Number





A division of Stovax Ltd

**Falcon Road, Sowton Industrial Estate, Exeter, Devon, England EX2 7LF**

**Tel: (01392) 474500 Fax: (01392) 219932**

**E-mail: [yeoman@stovax.com](mailto:yeoman@stovax.com) [www.yeoman-stoves.co.uk](http://www.yeoman-stoves.co.uk)**