



## INSTALLER AND OWNER GUIDE

Please keep me in a safe place for future use.

# Model 762

Inset live fuel effect gas fire for assembly with;

## Blakely fascia

We trust that this guide gives sufficient details to enable this appliance to be installed, operated and maintained satisfactorily. However, if further information is required, our **Valor Technical Helpline** will be pleased to help.

Telephone **0844 879 35 88** (National call rates apply in the United Kingdom).

In the Republic of Ireland Telephone **01 842 8222**.



**THIS APPLIANCE IS FOR USE WITH NATURAL GAS (G20).**

**WHEN CONVERTED USING CONVERSION KIT NO. 0595271 THIS APPLIANCE  
IS FOR USE WITH PROPANE GAS (G31).**

**THIS APPLIANCE IS SUITABLE ONLY FOR INSTALLATION IN THE UNITED  
KINGDOM (GB) AND THE REPUBLIC OF IRELAND (IE).**

**© GDC Group Ltd.**

All rights reserved. No part of this publication may be reproduced in any material form (including photocopying), stored in any medium by electronic means (including in any retrieval system or database) or transmitted, in any form or by any means, whether electronic, mechanical, recording or otherwise, without the prior written permission of the copyright owner.

Applications for the copyright owner's permission to reproduce any part of this publication should be made, giving details of the proposed use, to the following address: The Marketing Communications Manager, GDC Group Ltd, Millbrook House, Grange Drive, Hedge End, Southampton, SO30 2DF.

Warning: Any person who does any unauthorised act in relation to a copyright work may be liable to criminal prosecution and civil claims for damages.



Valor, GDC Group Ltd., Millbrook House,  
Grange Drive, Hedge End, Southampton,  
SO30 2DF. UK

[www.valor.co.uk](http://www.valor.co.uk)

**Because our policy is one of constant development and improvement, details may vary  
slightly from those given in this publication**

### **Safety First.**

Valor fires are CE Approved and designed to meet the appropriate British Standards and Safety Marks.



### **Quality and Excellence.**

All Valor fires are manufactured to the highest standards of quality and excellence and are manufactured under a BS EN ISO 9001 quality system accepted by the British Standards Institute.



### **The Highest Standards**

Valor is a member of SBGI and HHIC (Heating and Hot water Industry Council) that work to ensure high standards of safety, quality and performance.



### **Careful Installation**

This gas fire must be installed by a competent GAS SAFE REGISTER operative in accordance with our installer guide and should not be fitted directly on to a carpet or floor of combustible material.



# INSTALLER GUIDE

FOR OWNER GUIDE SEE PAGES 41 TO 58

# INSTALLER GUIDE

## CONTENTS

<u>Section</u>	<u>Page</u>
<b>INSTALLER GUIDE</b>	<b>5 - 40</b>
<b>OWNER GUIDE</b>	<b>41 - 58</b>
<b>1. IMAGE</b>	<b>7</b>
<b>2. SAFETY</b>	<b>8</b>
<b>3. ACCESSORIES</b>	<b>9</b>
<b>4. APPLIANCE DATA, EFFICIENCY AND NO<sub>x</sub></b>	<b>9</b>
4.1 General information.	9
4.2 Efficiency.	10
4.3 NO <sub>x</sub>	10
<b>5. GENERAL INSTALLATION REQUIREMENTS</b>	<b>10</b>
5.1 Regulations, Standards and Law.	10
5.2 Ventilation requirements.	11
5.3 The Atmosphere sensing device (ASD).	11
5.4 Fireguard requirements.	11
5.5 Room considerations.	11
5.6 Chimney preparation.	12
5.7 Fireplace preparation.	12
5.8 The hearth.	13
5.9 Fireplace clearances.	13
5.10 Installation options.	15
5.11 Flues.	16
5.12 Propane appliances.	16
<b>6. UNPACKING</b>	<b>17</b>
<b>7. PACK CONTENTS</b>	<b>18</b>
<b>8. FIREPLACE CHECK</b>	<b>20</b>
8.1 Fireplace check.	20
8.2 Fireplace flue pull.	21
<b>9. IGNITION CHECK</b>	<b>21</b>
9.1 Fitting batteries to the remote control handset.	21
9.2 Fitting batteries to the receiver box.	21
9.3 Setting the handset and receiver relationship.	22
9.4 Checking the ignition operation.	22
<b>10. GAS SUPPLY CONNECTION</b>	<b>22</b>
<b>11. PREPARING APPLIANCE FOR INSTALLATION</b>	<b>22</b>
<b>12. CONVECTION BOX INSTALLATION</b>	<b>23</b>
12.1 Method 1 - Front fixing to fireplace surround.	23
12.2 Method 2 - Cable retention and floor fixing.	24
12.3 Sealing floor front - All installations.	26

# INSTALLER GUIDE

## CONTENTS (CONTINUED)

<u>Section</u>	<u>Page</u>
<b>13. BURNER AND SUPPLY PIPE INSTALLATION</b>	<b>27</b>
13.1 Burner installation.	27
13.2 Supply pipe installation.	27
13.3 Burner checks.	27
13.3.1 Lighting the fire.	27
13.3.2 Adjusting flame height.	28
13.3.3 Adjusting to pilot only setting.	28
13.3.4 Turning off.	28
13.4 Check inlet pressure.	29
<b>14. FITTING THE CERAMIC FUEL EFFECT</b>	<b>29</b>
14.1 Fitting the rear ceramic wall.	29
14.2 Fitting the side ceramic walls.	29
14.3 Fitting the ceramic support.	29
14.4 Fitting the port cover.	29
14.5 Fitting the ceramic fuel effect.	30
<b>15. FULL OPERATING CHECKS</b>	<b>32</b>
15.1 Check the burner operation.	32
15.2 Check for spillage.	32
15.3 Flame supervision and spillage monitoring system.	32
<b>16. FASCIA INSTALLATION</b>	<b>33</b>
<b>17. FINAL REVIEW</b>	<b>34</b>
<b>18. SERVICING &amp; PARTS REPLACEMENT</b>	<b>35</b>
18.1 Checking the aeration setting of the burner.	36
18.2 To remove the window panel.	36
18.3 To remove the fuel effect.	36
18.4 To remove the ceramic side walls.	37
18.5 To remove the burner unit.	37
18.6 To remove the pilot unit.	37
18.7 To remove the gas valve.	38
18.8 To remove the receiver box.	39
18.9 To remove the thermocouple interrupter block.	39
18.10 To replace the burner.	39
18.11 To remove the burner injector.	40
18.12 To remove the appliance from the fireplace.	40

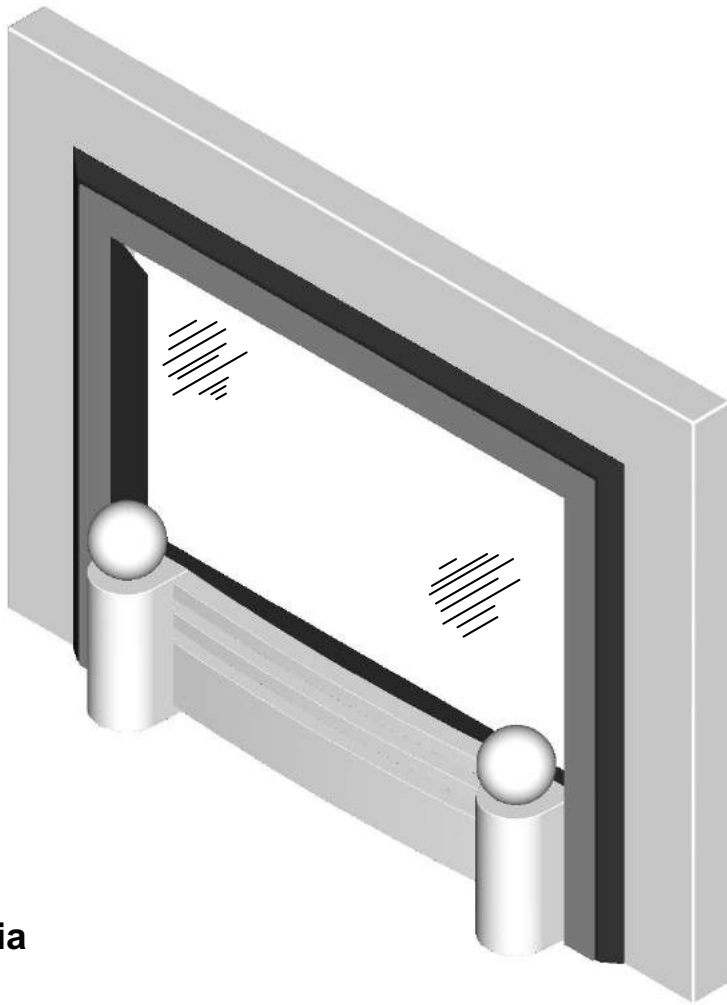

**Blakely fascia**

# INSTALLER GUIDE



## Installer

Before continuing any further with the installation of this appliance please read the following guide to manual handling.

- The lifting weight of this appliance (kg) is as below:

<u>Model</u>	<u>Heat Engine (Without ceramics)</u>	<u>Fascia</u>	<u>Fascia</u>
Blakely	22.14	6.62 (Fret)	8.54 (Frame)

This fire and the fascia are both heavy. We therefore recommend that two people should be sufficient to lift the fire or the fascia. If fitting or moving alone we recommend the use of suitable lifting apparatus.

- When lifting always keep your back straight. Bend your legs and not your back.
- Avoid twisting at the waist. It is better to reposition your feet.
- Avoid upper body/top heavy bending. Do not lean forward or sideways whilst handling the fire.
- Always grip with the palm of the hand. Do not use the tips of fingers for support.
- Always keep the fire as close to the body as possible. This will minimise the cantilever action.
- Use gloves to provide additional grip.
- Always use assistance if required.

**This product uses fuel effect pieces, burner compartment walls and ceramic gravel containing Refractory Ceramic Fibres (RCF), which are man-made vitreous silicate fibres. Excessive exposure to these materials may cause irritation to eyes, skin and respiratory tract. Consequently, it is important to take care when handling these articles to ensure that the release of dust is kept to a minimum. To ensure that the release of fibres from these RCF articles is kept to a minimum, during installation and servicing we recommend that you use a HEPA filtered vacuum to remove any dust and soot accumulated in and around the fire before and after working on the fire. When replacing these articles we recommend that the replaced items are not broken up, but are sealed within a heavy duty polythene bag, clearly labelled as RCF waste. RCF waste is classed as a stable, non-reactive hazardous waste and may be disposed at a landfill licensed to accept such waste. Protective clothing is not required when handling these articles, but we recommend you follow the normal hygiene rules of not smoking, eating or drinking in the work area and always wash your hands before eating or drinking.**

**This appliance does not contain any component manufactured from asbestos or asbestos related products.**



# INSTALLER GUIDE

## ACCESSORIES

Accessory                      Part number

LPG conversion kit              0595271

## 4. APPLIANCE DATA, EFFICIENCY AND NO<sub>x</sub>

### 4.1 General information.

Gas	Natural (G20)	LPG (G31)*
Inlet Pressure	20mbar	37mbar
Input - Max. (Gross)	5.7kW (19,448 Btu/h)	5.6kW (19,107 Btu/h)
Input - Min. (Gross)	2.0kW (6,824 Btu/h)	3.3kW (11,260 Btu/h)
Inlet Test Pressure (Cold)	20.0 ± 1.0mbar (8.0 ± 0.4in w.g.)	37.0 ± 1.0 mbar (14.85 ± 0.4in w.g.)
Gas Connection	8mm pipe	8mm pipe
Burner Injector	Cat 82 - 067	123
Pilot & Atmosphere Sensing Device	Copreci Ref. O.D.S 21100/224	Copreci Ref. O.D.S 21100/225
Ignition	Battery powered electronic remote control.	Battery powered electronic remote control.
<b>Aeration Setting</b>	<b>See section 18.1</b>	<b>See section 18.1</b>

\* When converted using kit 0595271.

The appliance information label is located under the burner on the right hand side of the fire. This can be seen by removing the fascia.

### 4.2 Efficiency.

The efficiency of this appliance has been measured as specified in BS 7977 - 1 and the result is as below :

<u>Model</u>	<u>Efficiency % (Gross)</u>
762 Blakely	75.6
762 Blakely when converted to LPG.	75.6

# INSTALLER GUIDE

The gross calorific value of the fuel has been used for this efficiency calculation. The test data from which it has been calculated has been certified by Advantica Certification services (0087). The efficiency value may be used in the UK Government's Standard Assessment Procedure (SAP) for energy rating of dwellings.

The conversion of **net** efficiency to **gross** was achieved by multiplying the net efficiency by the following conversion factor from Table E3 of SAP 2005, rounding down to the nearest whole number.

Gas	Conversion factor from <b>net</b> to <b>gross</b> efficiency
Natural Gas	0.901
LPG	0.921

## 4.3 NO<sub>x</sub>

For NG the 'Weighted' result for this appliance equates to NO<sub>x</sub> Class 5.

For LPG the 'Weighted' result for this appliance equates to NO<sub>x</sub> Class 4.

# GENERAL INSTALLATION REQUIREMENTS

## 5.1 Regulations, Standards and Law.

The installation must be in accordance with these instructions.

For the user's protection, in the United Kingdom it is the law that all gas appliances are installed by competent persons in accordance with the current edition of the Gas Safety (Installation and Use) Regulations. Failure to install the appliance correctly could lead to prosecution. GAS SAFE REGISTER require their members to work to recognised standards.

In the United Kingdom the installation must also be in accordance with:

All the relevant parts of local regulations.

All relevant codes of practice.

The relevant parts of the current editions of the following British Standards:-

- BS EN 1856 Part 1 Chimneys - Requirements for metal chimneys.
- BS 5440 Part 1 Installation of flues.
- BS 5440 Part 2 Installation and maintenance of flues and ventilation for gas appliances of rated input not exceeding 70 kW net (1st, 2nd and 3rd family gases).
- BS 6461 Part 1 Masonry chimney & flues - Installation.
- BS 1251 Fireplace components.
- BS 5871 Part 2 Installation - Inset LFE gas fires.
- BS 6891 Gas pipework installation.

– In England and Wales, the current edition of the Building Regulations issued by the Department of the Environment and the Welsh Office.

# INSTALLER GUIDE

- In Scotland, the current edition of the Building Standards (Scotland) Regulations issued by the Scottish Executive.
- In Northern Ireland, the current edition of the Building regulations (Northern Ireland) issued by the Department of the Environment for Northern Ireland.
- In the Republic of Ireland the installation must be carried out by a competent person and also conform to the relevant parts of:
  - a) The current edition of IS 813 “Domestic Gas Installations”
  - b) All relevant national and local rules in force.

Where no specific instructions are given, reference should be made to the relevant British Standard Code of Practice.

## 5.2 Ventilation requirements.

Normal adventitious ventilation is usually sufficient to satisfy the ventilation requirements of this appliance. In GB reference should be made to BS 5871 Part 2 and in IE reference should be made to the current edition of IS 813 “Domestic Gas Installations” which makes clear the conditions that must be met to demonstrate that sufficient ventilation is available.

## 5.3 The Atmosphere sensing device (ASD).

The appliance is fitted with an A.S.D (Atmosphere sensing device). If the appliance closes down after a period of operation for no apparent reason, the consumer should be informed to stop using the appliance until the installation and appliance have been thoroughly checked. The A.S.D will shut the appliance down if an unacceptable amount of harmful products of combustion accumulate. Under no circumstances should the A.S.D be altered or bypassed in any way. Only a genuine manufacturer’s replacement part should be fitted. The individual A.S.D components are not replaceable.

## 5.4 Fireguard requirements.

A fireguard complying with BS 8423 should be fitted for the protection of young children, the elderly, the infirm and pet animals.

## 5.5 Room considerations.

**5.5.1** This appliance must not be installed in any room that contains a bath or shower or where steam is regularly present.

**5.5.2** An extractor fan may only be used in the same room as this appliance, or in any area from which ventilation for the appliance is taken, if it does not affect the safe performance of the appliance. Note the spillage test requirements detailed further on in this manual. If the fan is likely to affect the appliance, the appliance must not be installed unless the fan is permanently disconnected.

**5.5.3** Note that soft wall coverings (e.g. embossed vinyl, etc.) are easily affected by heat. They may scorch or become discoloured when close to a heating appliance. Please bear this in mind when installing.

# INSTALLER GUIDE

## 5.6 Chimney preparation.

**5.6.1** If the appliance is intended to be installed to a chimney that was previously used for solid fuel, the flue must be swept clean prior to installation. All flues should be inspected for soundness and freedom from blockages.

**5.6.2** Any chimney damper or restrictor should be removed. If removal is not possible, they must be secured in the open position.

## 5.7 Fireplace preparation.

**5.7.1** If the fireplace opening is an underfloor draught type, it must be sealed to stop any draughts.

**5.7.2** The fireplace floor should be reasonably flat to ensure that a good seal with the convection box can be made.

**5.7.3** The front face of the fireplace should be reasonably flat over the area covered by the convection box top and side flange seals to ensure good sealing. These faces should be made good if necessary.

**5.7.4** If the appliance is to be fitted against a wall with combustible cladding, the cladding must be removed from the area covered by the fascia. The cladding must also not touch the fascia (See figure 1). We suggest that the actual fascia is used as a template to mark the area for combustible cladding removal and that this area is increased by at least 2mm all round.

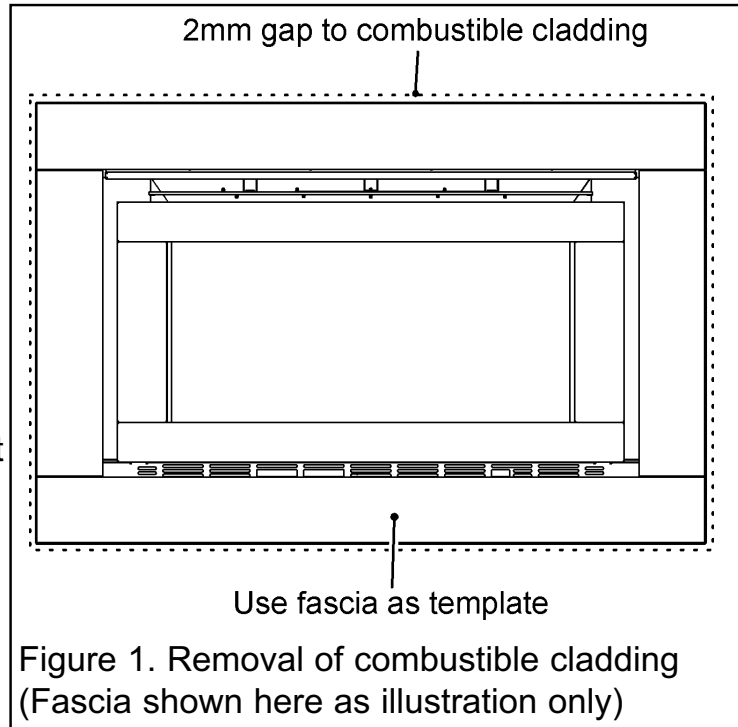

**5.7.5** If the fireplace opening is greater than the acceptable dimensions given in this guide, do not use the back of a fire surround or marble to reduce the opening. This may cause cracking of the surround back or marble.

# INSTALLER GUIDE

## 5.8 The hearth.

The appliance must be mounted behind a non-combustible hearth unless the conditions of section 4.10.2 are met (N.B. conglomerate marble hearths are considered as non-combustible). The appliance can be fitted to a purpose made proprietary class “O”-150°C surround. The hearth material must be at least 12mm thick. The periphery of the hearth (or fender) should be at least 50mm above floor level to discourage the placing of carpets or rugs over it.

The surface of the hearth must be sufficiently flat to enable the bottom of the front surround and the bottom front cover to be aligned horizontally. Any excessive unevenness (uneven tiles, Cotswold stone, etc.) should be rectified.

The appliance must not stand on combustible materials or carpets.

## 5.9 Fireplace clearances.

**5.9.1** The minimum height from the base of the fireplace opening to the underside of any shelf made from wood or other combustible materials is detailed below:

- For a shelf up to 150mm deep: Minimum height = 750mm.
- For a shelf deeper than 150mm: 750mm + 12.5mm for every 25mm depth over 150mm (See Figure 2).

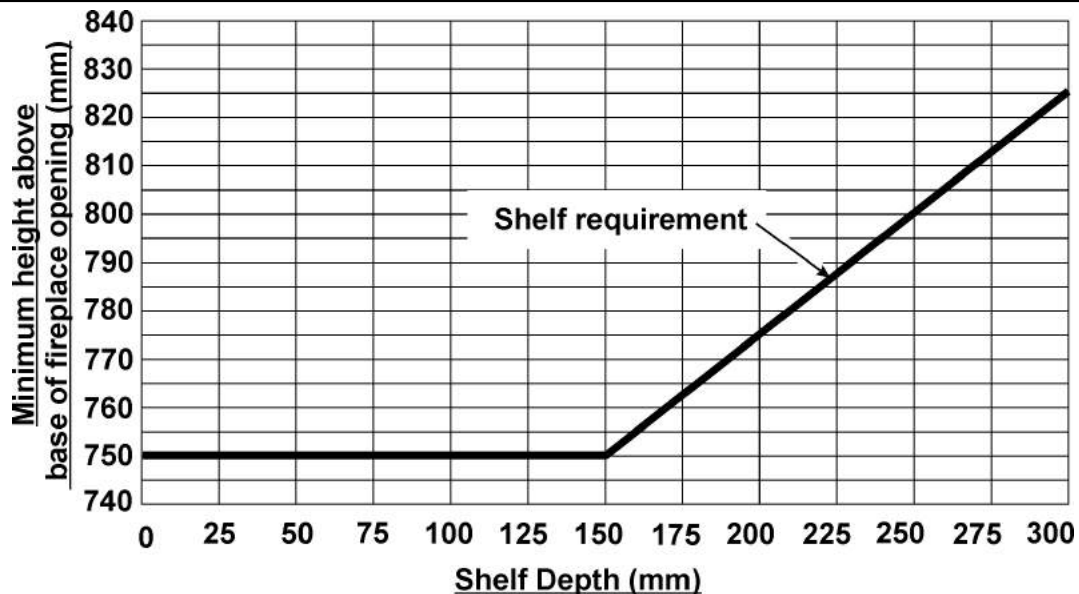
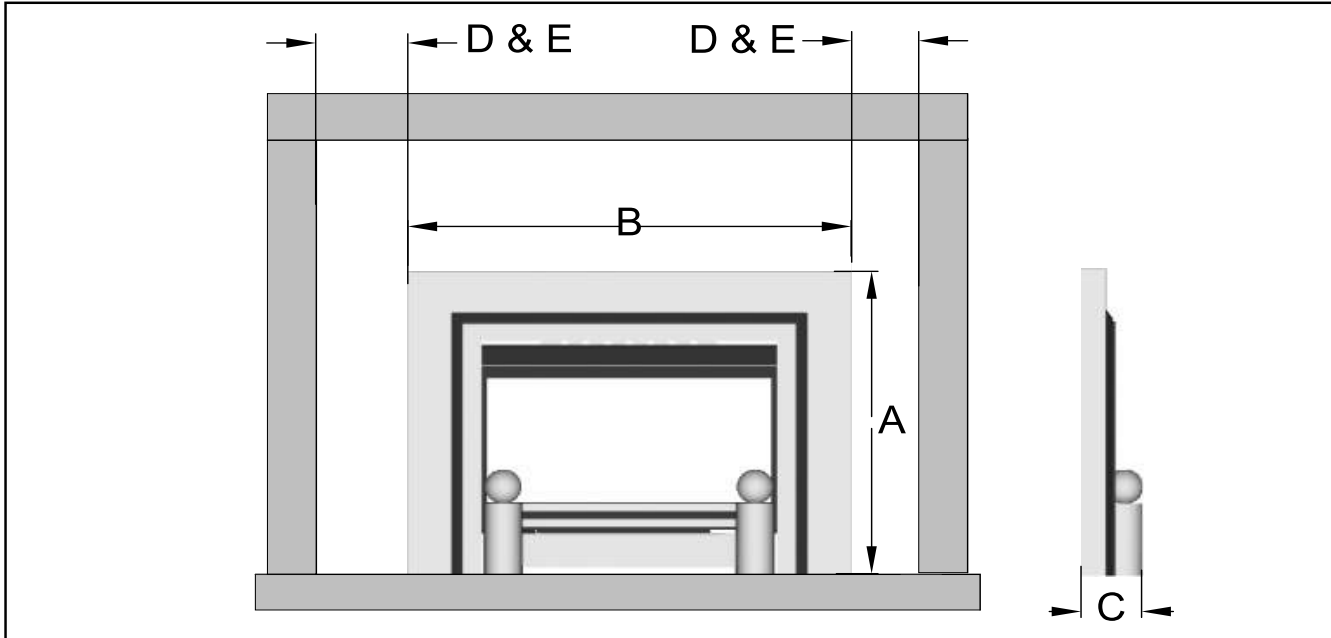

Figure 2. Combustible shelf clearances

# INSTALLER GUIDE

**5.9.2 Blakely Fascia** - The minimum allowable distance from the outside of the appliance fascia to a corner wall having combustible material or any other combustible surface which projects beyond the front of the appliance is shown in figure 3.

A 10mm access clearance from a non-combustible surface is necessary at the left side.



Key	Description	Blakely Model
A	Height (mm)	680
B	Width (mm)	930
C	Depth into room (mm)	130
D	Minimum <b>mandatory</b> clearance to <b>combustible</b> surfaces projecting beyond the front of appliance (mm)	75
E	<b>Recommended</b> clearance to <b>non-combustible</b> surfaces for access purposes (mm)	50

Figure 3. Blakely fascia - Appliance dimensions and clearances (Dimensions are subject to manufacturing tolerances)

# INSTALLER GUIDE

## 5.10 Installation options.

In the United Kingdom, as supplied, the appliance can be installed in the following situations:

### 5.10.1 Conventional fireplace and hearth.-

To a fireplace opening and hearth as shown in figure 4 and complying with BS1251 after removal of the fireback and sufficient material behind the fireback for a debris catchment space. The required fireplace, hearth, debris catchment area and clearance dimensions are shown in figure 5.

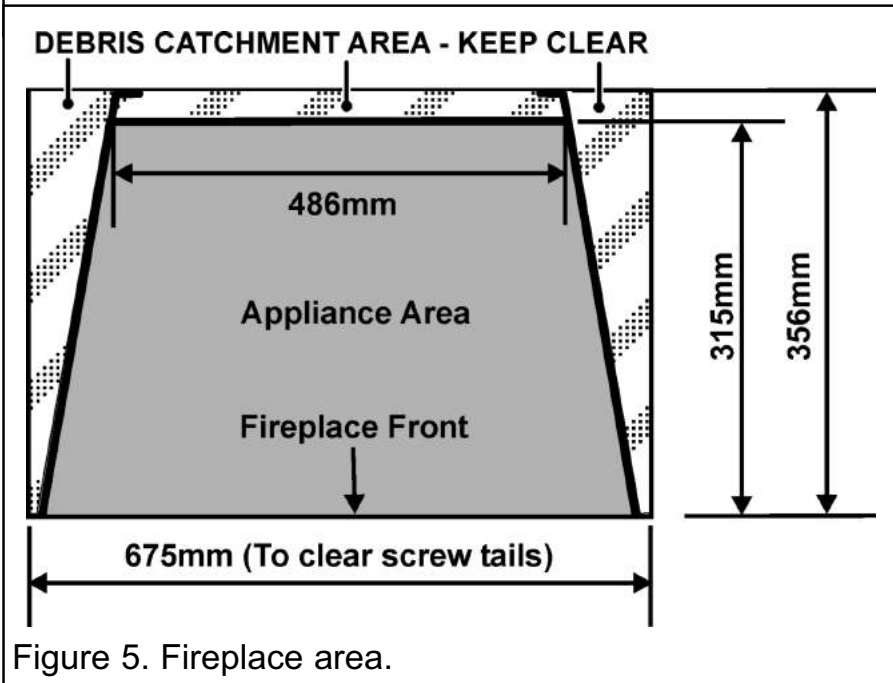
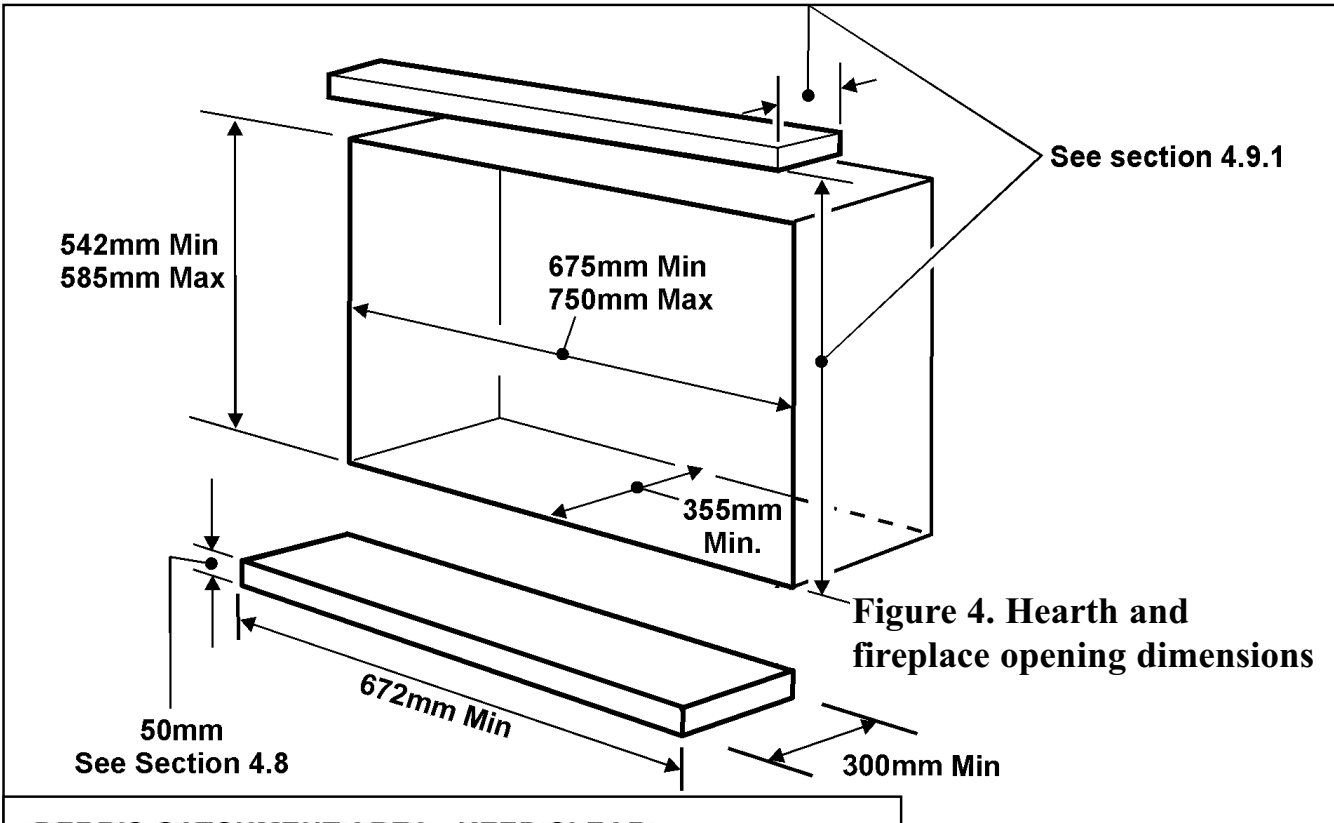

## 5.11 Flues.

1. Suitable flues and minimum flue sizes are as follows: -

*It should be noted that, as with many appliances, sharp bends or horizontal runs in metal flues at the top of the system can be a cause of problems in these types of installation.*

- 225mm x 225mm conventional brick flue.
- 125 or 175mm diameter lined brick or stone flue.
- 200mm diameter factory made insulated flue manufactured to BS4543 Part 2.
- 175mm diameter flue pipe. See BS6461 Part 1 for suitable materials.
- Single wall, twin wall or flexible flue liner with a minimum diameter of 125mm. The materials to be used are stainless steel or aluminium as specified in BS EN 1856 Part 1. The liner must be sealed to the surrounding area above the fireplace opening and to the top of the chimney. An approved terminal must be fitted.

2. The flue must conform to BS 5440: Part 1 in design and installation.

The flue, measured from the bottom of the fireplace opening to the bottom of the terminal, shall be not less than 3m in actual vertical height. When calculated in accordance with BS 5440: Part 1 Annex A, the minimum equivalent height of the flue shall be 2.0m of 125mm dia. flue pipe.

3. The flue must not be used for any other appliance or application.

4. Proprietary terminals must comply with BS 715 or BS 1289. Any terminal or termination must be positioned in accordance with BS 5440 Part 1 to ensure that the products of combustion can be safely dispersed into the outside atmosphere. Where the appliance is connected to an unlined brick chimney it is generally unnecessary for the chimney pot to be replaced or for a terminal to be fitted unless the flue has a diameter smaller than 170mm.

## 5.12 Propane appliances.

Propane gas appliances must not be installed in a room that is built entirely below ground level (See BS 5871 Part 2).



# INSTALLER GUIDE

## UNPACKING

1. The ceramic fuel effect is packed inside the convector box. The window panel is secured at the bottom with two clamps. To release the clamps, hold at the rear and pull down (See figure 6).

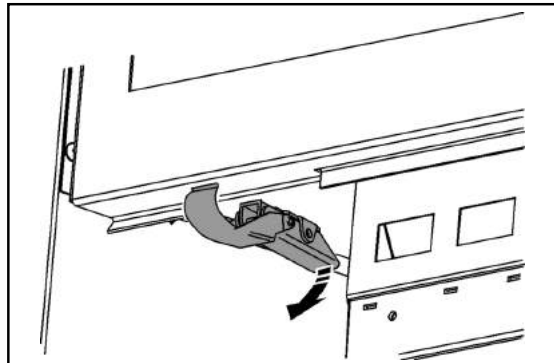

Figure 6. Window panel clamp

2. With both clamps released, gently pull the base of the window panel forward. Hold the window panel base and lift upward until clear of the two upper window retainers (See figure 7).

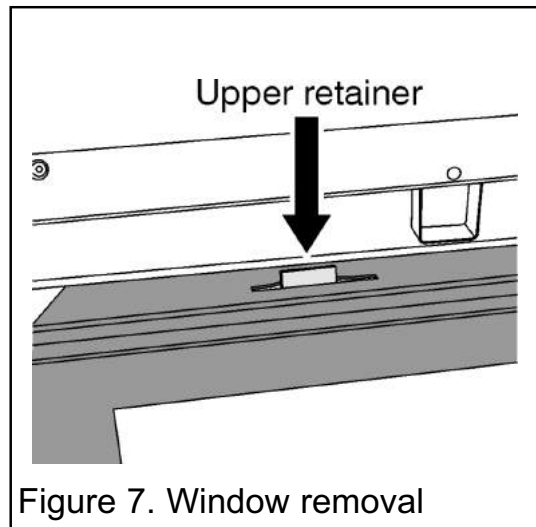

Figure 7. Window removal

3. Gently remove the ceramic fuel effect pack.

# INSTALLER GUIDE

## PACK CONTENTS

The items required for this appliance are packed in sections.

**The ceramic walls are fragile. They are packed inside the top fitment as you open the carton.**

### Section 1 - Fire unit contains:

- 1 Burner and convection box unit.
- 2 Lengths of self adhesive foam seal.
- 2 Cable clamps.
- 2 Fire retaining cables.
- 4 Eyebolts.
- 7 Wood screws.
- 7 Fibre / wooden plugs.
- 2 Strips of floor sealing tape.
- 1 'T' connector and pressure test point.
- 1 Nut and olive for 8mm inlet pipe.
- 1 'PP3' Battery.
- 4 'AA' Batteries.
- 1 Smoke match tube.
- 1 Ceramic wall set.
- 1 Remote control handset.
- 1 Port cover.
- 3 No.8 x 3/8" Tapping Screws (For port cover).
- 1 Ceramic support.
- 3 No.8 x 3/8" Tapping Screws (For ceramic support).
- 1 Rubber grommet (For rear of convector box).
- 1 Literature pack.
- 1 Ceramic fuel effect set (Not shown).
- 1 Tray for ceramic gravel.
- 2 Window side trims.
- 2 Fireback spacing brackets.
- 4 No.8 x 3/8" Tapping Screws (For fireback spacing brackets).
- 2 Thumbscrews for fascia securing.
- 2 Washers for fascia securing.
- 1 Flue Restrictor
- 3 No.8 x 3/8" Tapping screws

### Section 2 - fascia pack contains:

- 1 Fascia. (Ref. p20)

Carefully remove all the contents. Take special care in handling the ceramic pieces. Check that all the listed parts are present and in good condition.

# INSTALLER GUIDE

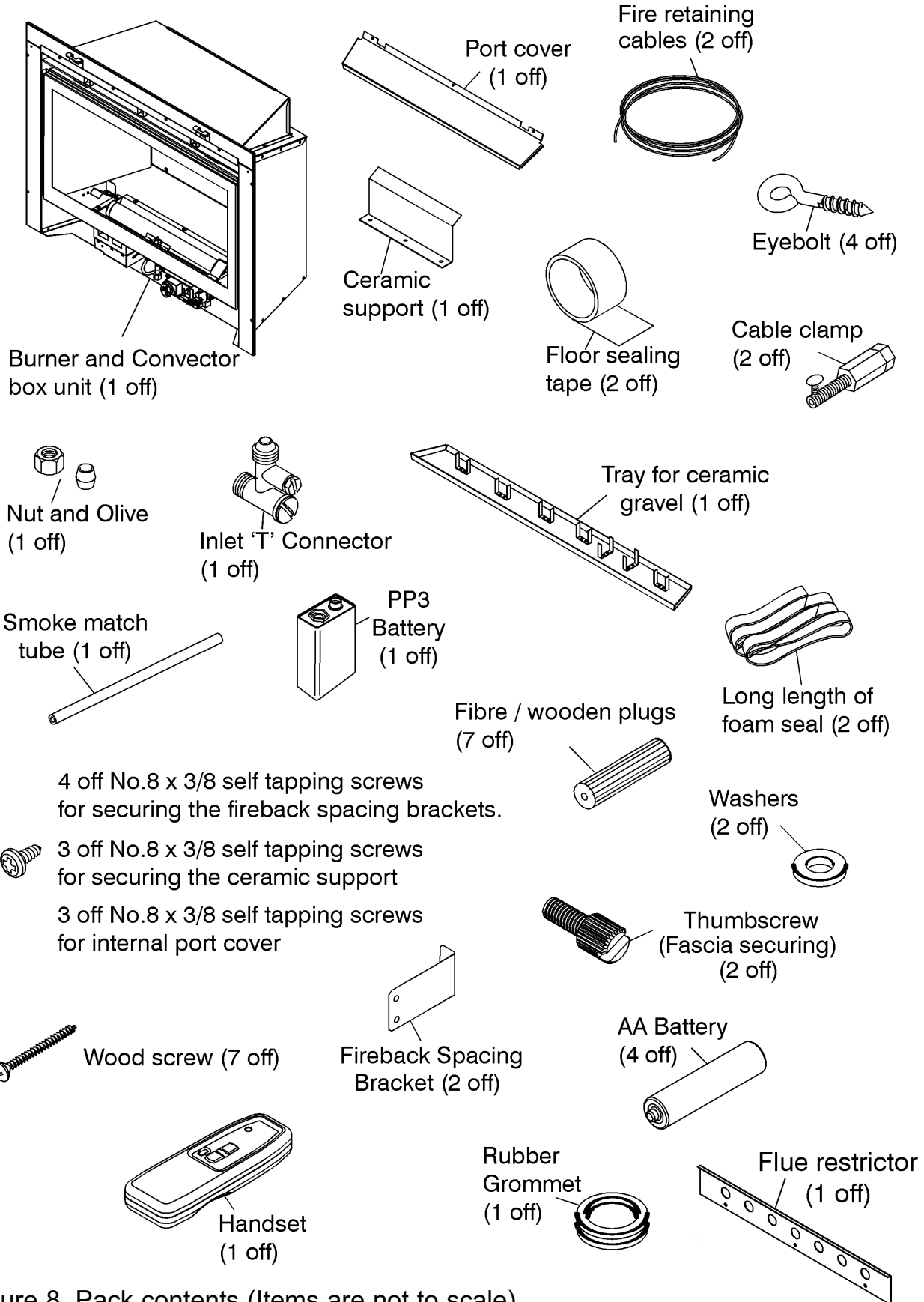

Figure 8. Pack contents (Items are not to scale)

## INSTALLER GUIDE

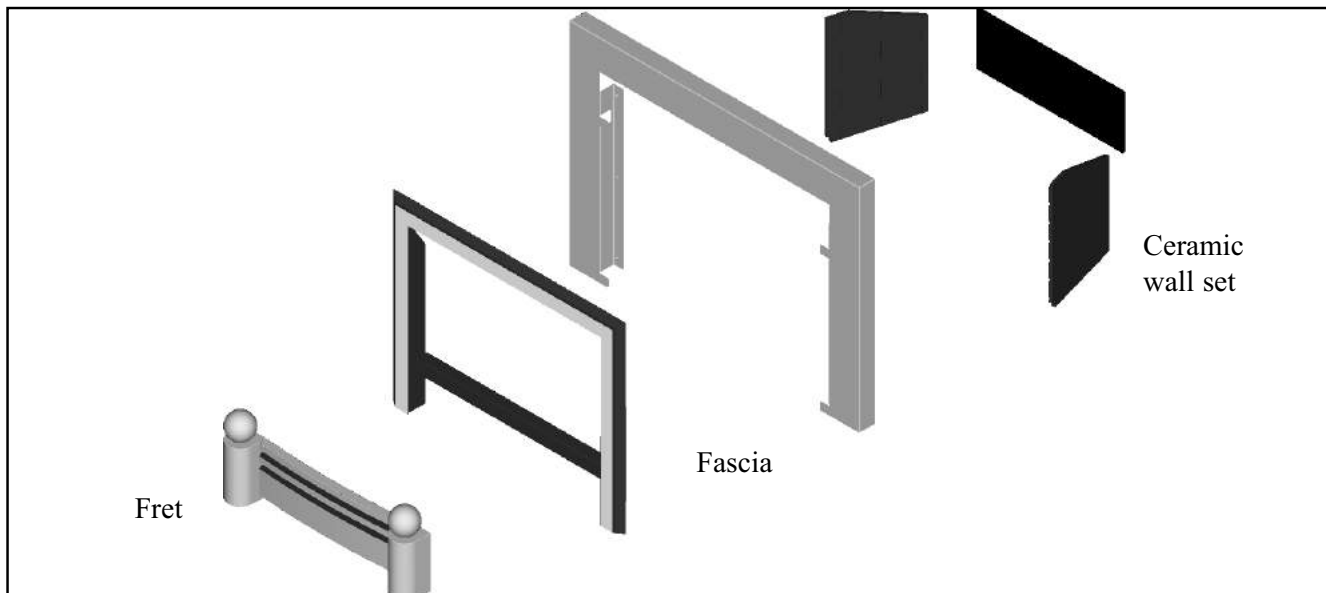

Figure 8A. Blakely fascia - Pack contents continued (Items are not to scale)

**NOTE:** The Blakely appliance is supplied with a flue restrictor, this should be fitted if the flue height is greater than 4.3m (14ft), with a good draught present. Generally we recommend the flue restrictor is not fitted to precast flues or metal flue box installations. There may be circumstances where fitting the restrictor causes the fire to fail the spillage test, in such cases the restrictor will have to be removed. After removal conduct the spillage test again.

## FIREFLACE CHECK

### 8.1 Fireplace check.

#### 8.1.1 Fireplace size.

The fireplace must comply with the requirements described in section 5.10. This will probably entail removing the fireback and infill material behind the fireback. The debris catchment area shown in figure 5 must be kept clear of obstructions.

#### 8.1.2 Fireplace general condition.

The fireplace floor should be reasonably flat to ensure that the convection box can be installed without it rocking and so that a good seal can be made at the bottom front of the box. The front face of the fireplace should be reasonably flat over the area covered by the convection box top and side flange seals to ensure good sealing. These faces should be made good if necessary. If the appliance is to be fitted against a wall with combustible cladding, the cladding must be removed from the area covered by the fascia. The cladding must also not touch the fascia (See figure 1). We suggest that the actual fascia is used as a template to mark the area for combustible cladding removal and that this area is increased by at least 2mm all round.

#### 8.1.3 Soundness for appliance attachment

Two primary methods of retaining the appliance are provided: -

# INSTALLER GUIDE

- 1) By fixing to the fireplace front.
- 2) Using concealed tension cables fixed to the rear of the fireplace opening together with secondary fixing to the fireplace floor.

The methods are detailed in section 12 of this manual. Before selecting the retention method, consult with the customer. Method 2 is provided for instances where drilling holes in the front surface of the fireplace surround is unacceptable to the customer or otherwise impractical. *N.B. It is unwise to attempt to drill into marble without the proper tools and equipment.*

If method 1 is chosen, make sure that the front surround area is sound enough to take the fibre / wooden plugs and wood screws. If necessary, make sound with suitable cement.

If method 2 is chosen, make sure that the areas at the back and towards the centre of the fireplace floor are sound enough to take the eyebolts and screws. If these areas have deteriorated due to prolonged use, they should be made sound with suitable cement.

## 8.2 Fireplace flue pull.

Close all doors and windows in the room in which the appliance is to be installed. After confirming with a match that smoke is drawn into the flue, light a 13 gram smoke pellet and check that there is a definite flow through the flue. Verify outside that the smoke exits from one terminal only and that the termination is suitable. Observe where possible, upstairs rooms and loft spaces for signs of escaping smoke indicating a defective flue. If there is not a definite flow warm the flue for a few minutes and repeat the smoke pellet test. If there is still no definite flow the flue may need remedial work – **Do not fit the appliance until there is a definite flow through the flue.**

## IGNITION CHECK

Before attempting to install, it is worth checking that the ignition system performs satisfactorily.

### 9.1 Fitting batteries to the remote control handset.

The remote control handset is battery powered. There is a 9 Volt 'PP3' size alkaline battery supplied. Remove the rear battery compartment cover from the remote control handset. To do this push the tab towards the bottom of the handset and lift (See figure 9). Fit the battery in to the handset. Replace the cover.

### 9.2 Fitting batteries to the receiver box.

The gas valve and receiver are battery powered. There are four 1.5 Volt 'AA' size alkaline batteries supplied. Locate the batteries in the receiver box. To do this slide the receiver box forward and clear of its support. Slide the battery compartment cover clear (See figure 9) and fit the batteries. It is important that the positive (+ve) and negative (-ve) symbols on the battery match those of the illustration inside the battery holder. Replace the cover and receiver box.

**It is important that the wires from the receiver box do not touch the underside of the burner tray.**

# INSTALLER GUIDE

## 9.3 Setting the handset and receiver relationship.

The receiver will have to be set to learn the handset / remote code. Do this as below:

Place the 'ON/OFF' switch to the '-' (On position). This is on the right hand front of the appliance.

Press and hold the reset button on the receiver (See figure 10) until you hear two (2) acoustic signals. After the second, longer acoustic signal, release the reset button.

Within the subsequent 20 seconds press the  (small flame) button on the handset until you hear an additional long signal confirming the code is set (Please inform the customer that this is a one time setting as is NOT required when changing batteries in the handset or receiver).

## 9.4 Checking the ignition operation.

Simultaneously press and hold the 'OFF' and  (large flame) buttons until a short acoustic signal confirms the start sequence has begun; release buttons.

Continuing signals confirms the ignition is in progress. There will be a slight delay and several sparks should be seen between the electrode and pilot tip (See figure 11).

On sensing a flame is not present the burner unit will shut off. If there are no sparks check the following:

Ensure that the electrode lead is connected to the terminal at the base of the electrode.

If the above is correct, check for damage to the electrode lead.

## 1 1 1 GAS SUPPLY CONNECTION

The fire is designed for a rear concealed connection only.

A nut and olive are provided for an 8mm pipe inlet connection to the 'T' connector at the bottom front of the appliance. The 'T' connector can be rotated to allow connection and includes a valve for isolating the gas supply and a pressure test point. The supply pipe must be rigid material. Flexible pipe must not be used. **Before the appliance is fitted into the fireplace** it will be necessary to extend the supply line so that it will project through the hole in the back of the convection box and run to the 'T' connector at the front. The pipe run from the supply line up to the rear opening in the convection box must be kept away from the area which will be taken by the convection box when it is installed (See figure 5).

Note that the centre of the appliance inlet 'T' connector is 25mm above the fireplace floor. The inlet 'T' connector should be fitted to the supply pipe at this stage.

## 1 1 1 PREPARING APPLIANCE FOR INSTALLATION

1. Detach the burner unit and support tray from the convection box by removing six screws (See figure 12). Lift the burner unit clear.

# INSTALLER GUIDE

## IMPORTANT

Before continuing with the installation of this gas fire the aeration setting on the burner must be checked. The aeration is factory set and should not require adjustment. See section 19.1 (Servicing and parts replacement).

2. It is important that the grommet supplied in the loose parts pack is fitted to the hole in the rear of the convection box.

3. Pierce the grommet to allow the pipe to pass through it. The grommet should envelop the pipe. If the hole is larger than the pipe, seal it with tape. **Do not pierce the grommet unless the supply pipe is to pass through it.**

4. The appliance is supplied with two fireback spacers that must be fitted in all installations. These should extend backwards to ensure sufficient clearance from the back of the fireplace. Position the fireback spacer as shown in figure 13. Secure the fireback spacers using four No.8 x 3/8" tapping screws supplied with the fire.

5. The **Blakely appliance** is supplied with a flue restrictor for use where the flue draught is excessive. There may however, be certain circumstances where fitting the restrictor causes the fire to fail the spillage test. In such cases the restrictor will have to be removed. After removal conduct the spillage check again.

The restrictor is packed loose with the appliance and is fixed with three No.8 x 3/8" tapping screws (See figure 13B).

6. There is a length of self adhesive foam seal supplied with the fire. This will need to be fitted to the outer rear edges of the side and top flanges of the convector box. Ensure that there is no gap between the foam seals where they meet (See figure 14). It is important that the bottom of the side flanges are sealed. Where the wall surface is uneven an additional length of foam seal is supplied and can be placed on top of the first layer.

When doing this ensure that the sides and top are covered in the same way as the first layer.

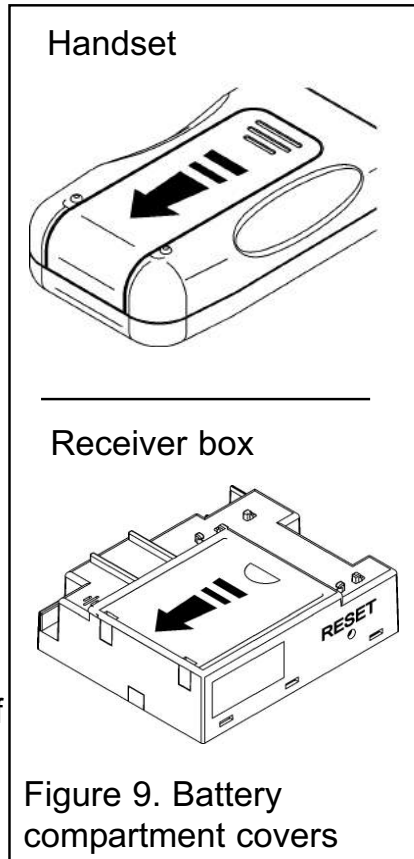

## CONVECTION BOX INSTALLATION

### 12.1 Method 1 - Front fixing to fireplace surround.

1. Make sure that the fireplace front surround area is sound enough to take the fibre / wooden plugs and wood screws. If necessary, make sound with suitable cement.

2. Place the convection box centrally in the fireplace in the position in which it is to be permanently installed. Insert the convection box into the fireplace feeding the supply pipe through the pierced hole in the rear grommet.

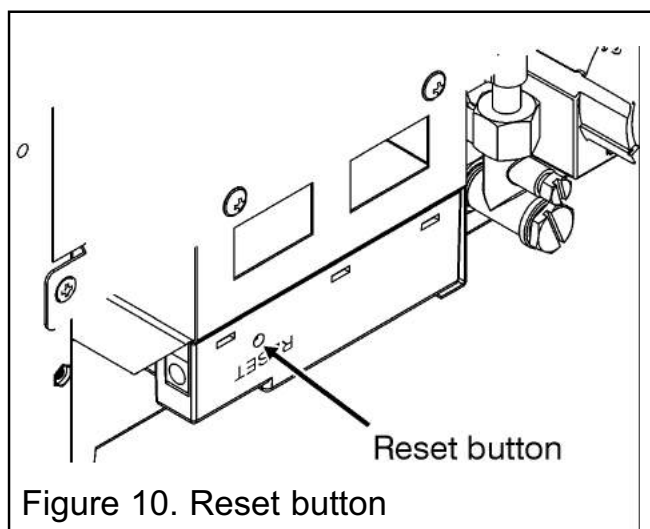

# INSTALLER GUIDE

3. Mark the fireplace front surround through the seven fixing holes in the side flanges of the convection box (See figure 15).

4. Remove the convection box. Drill four holes in the fireplace front surround at the marked positions using a suitably sized masonry drill for the fibre / wooden plugs supplied.

5. Insert a fibre / wooden plug into each hole.

6. Place the convection box back in position in the fireplace.

7. Fit a wood screw through each hole in the convection box flanges and tighten to seal the box to the fireplace surround.

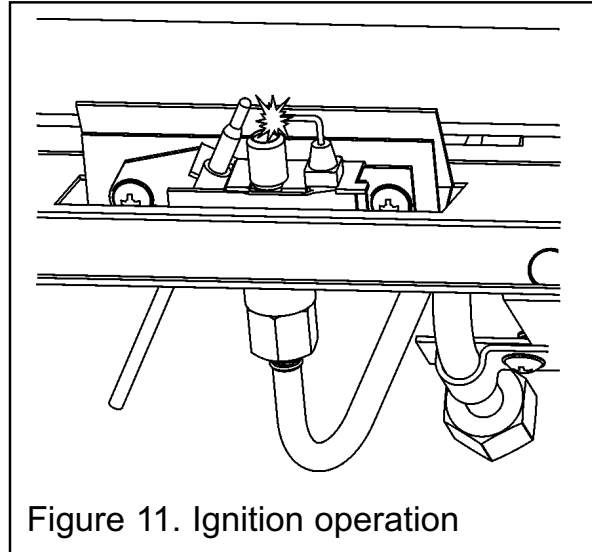

Figure 11. Ignition operation

## 12.2 Method 2 - Cable retention and floor fixing.

1. Make sure that the relevant areas at the fireplace back and floor are sound enough to take the eyebolts and screws. If these areas have deteriorated due to prolonged use they should be made sound with suitable cement.

2. Drill four holes in the rear wall of the fireplace for the fibre / wooden plugs. The holes should be drilled within the range of positions shown in figure 16 using a suitably sized masonry drill for the fibre / wooden plugs supplied. The holes should be equidistant each side of the centre line of the fireplace to ensure that the appliance finishes centrally in the opening when tension is applied to the cables.

3. Insert a fibre / wooden plug into each hole. Use the fibre / wooden plugs supplied with this appliance - **Never use plastic plugs instead of the fibre / wooden plugs supplied.** Screw the eyebolts into the plugs. Make sure that the bolts are secure.

4. Place the convection box fully back into the fireplace opening so that it is sealed against the fireplace front surround.

5. Mark the base of the fireplace through the holes in the fire base (See figure 17). Remove the fire from the fireplace.

6. Drill a hole into the fireplace floor through each of the two holes using a suitably sized masonry drill for the fibre / wooden plugs supplied.

7. Insert a fibre / wooden plug into each hole. Use the fibre / wooden plugs supplied with this appliance - **Never use plastic plugs instead of the fibre / wooden plugs supplied.** Place the fire in position and fit a wood screw in each hole and tighten.

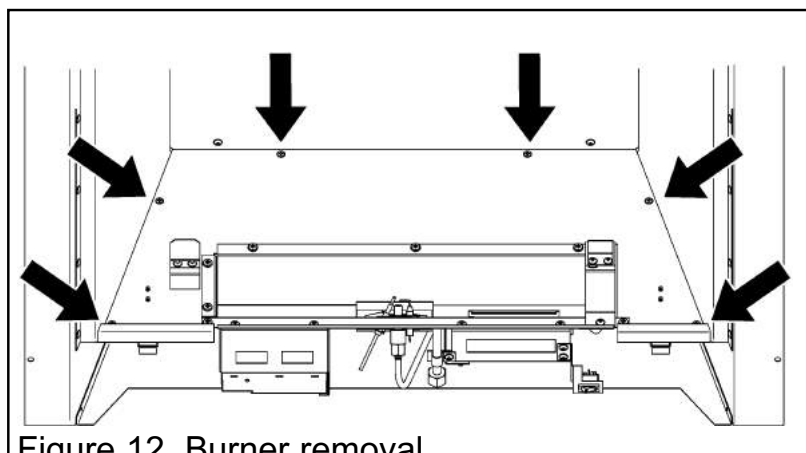

Figure 12. Burner removal



# INSTALLER GUIDE

**Always screw the base into position before applying tension to the cables. This will ensure a tight seal between the top of the convection box and wall.**

**8.** The convection box has two slots at each side of the flue outlet. Loop one end of each cable and pass the loop into the slots (See figure 18). Give the cables a pull so that they grip.

**9.** Place the convection box unit close to the fireplace but allow sufficient access into the fireplace opening so that the cables can be threaded through the eyebolts and returned through the back of the convection box. If a concealed connection is being used, insert the convection box into the fireplace feeding the supply pipe through the pierced hole in the rear grommet.

**10.** Thread the cables through the eyebolts. Return the cables through the holes near the bottom of the convection box back panel (See figure 19).

**11.** Fit a cable retainer over the bottom end of each cable.

**12.** Pull each cable taut. Push the cable retainers hard up against the back panel. The end of the cable adjuster will pass into the hole. Tighten the screws in the retainers so that they clamp the

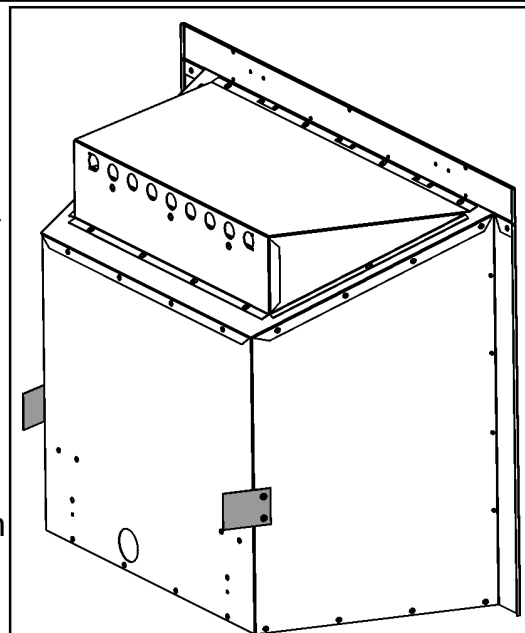

Figure 13. Fireback spacers.

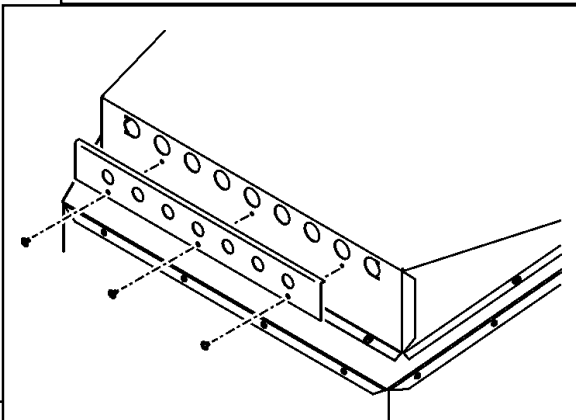

Figure 13B. Flue restrictor

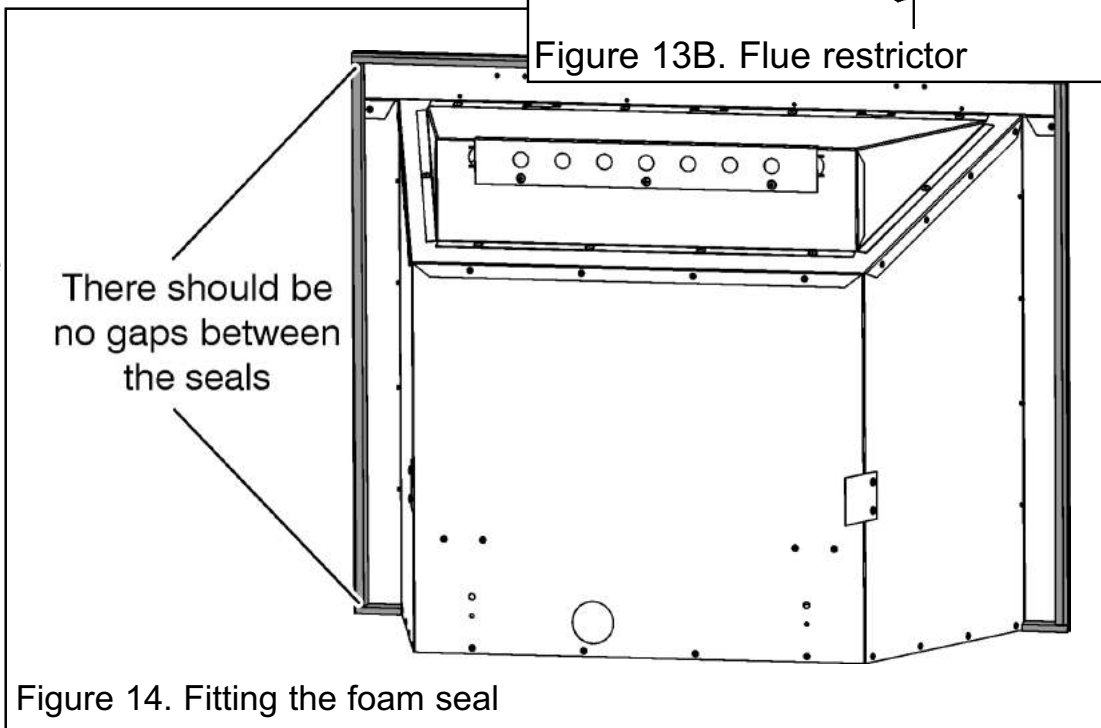

Figure 14. Fitting the foam seal

# INSTALLER GUIDE

cables in position. Apply tension to the cables by turning the hexagonal adjusters by hand (See figure 20).

**13.** Inspect the installation of the convection box against the fireplace surround. If the convection box is aligned squarely and the sealing is satisfactory, fully tighten the cable retainers.

**14.** If the convection box is not correctly aligned, release the tension on the cables by slackening the screws and turning the hexagonal adjusters fully anticlockwise. The convection box should then automatically realign itself. Pull each cable taut again and push the cable retainers back against the back panel. Again, tighten the screws in the retainers and apply tension to the cables by turning the hexagonal adjusters clockwise as far as possible.

**15.** Feed the free length of the cables through the small holes in the back of the convection box immediately below the cable adjusters so that they are available to allow easy removal and refitting of the appliance during subsequent service calls. **Do not cut off the free lengths of cable** (See figure 20).

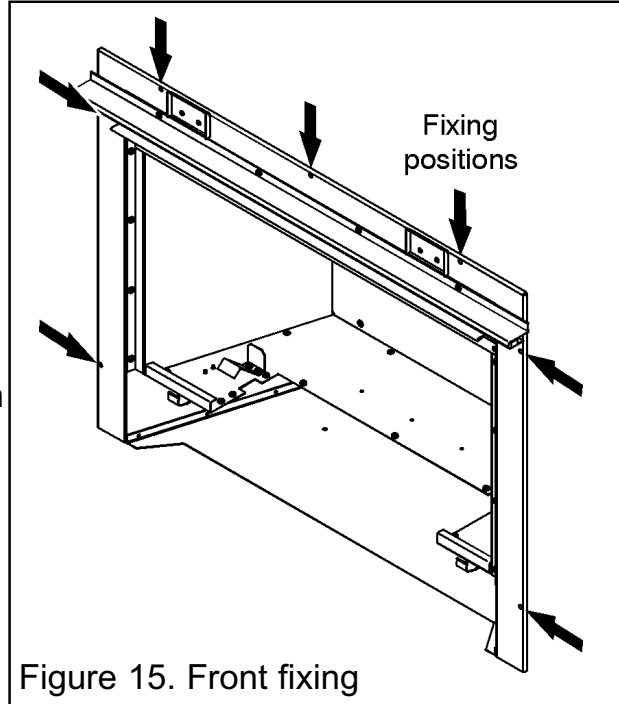

Figure 15. Front fixing

## 12.3 Sealing floor front - All installations.

Using the floor sealing tape supplied, seal the bottom of the convection box to the fireplace and hearth floor (See figure 21).

**Make sure that the whole length of the front edge of the convection box is fully sealed.**

A second strip of floor sealing tape is supplied. Use this to seal any small holes that remain at the lower rear and sides of the convection box.

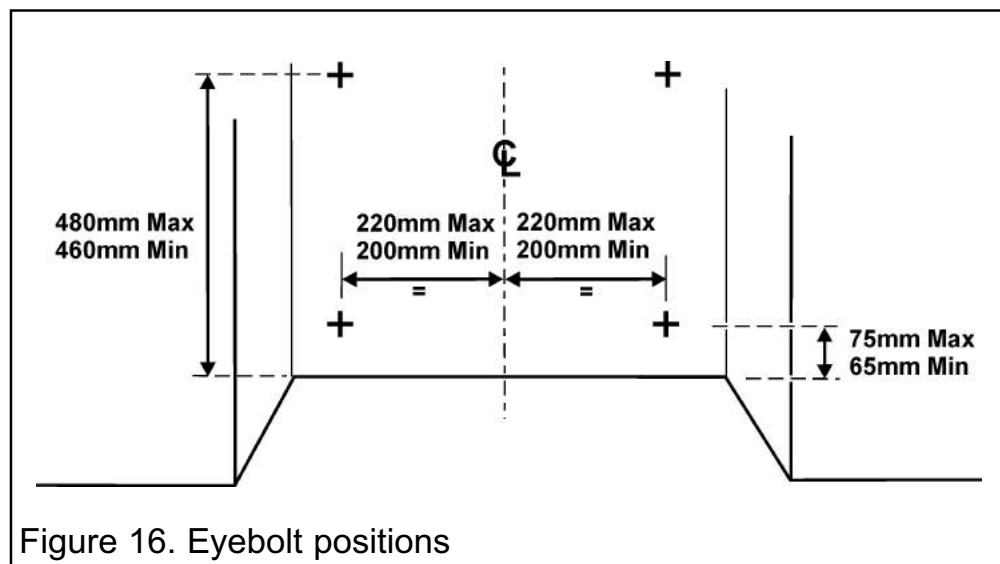

Figure 16. Eyebolt positions

### 13.1 Burner installation.

1. Remove the 'Aeration checking' reminder label from the top of the burner.
2. Refit the burner unit to the convection box with the six screws removed previously.

### 13.2 Supply pipe installation.

1. A nut and olive is provided for an 8mm-pipe inlet connection directly to the gas control. The isolating 'T' connector can be rotated to allow a connection from the rear. The 'T' connector includes a valve for isolating the gas supply.

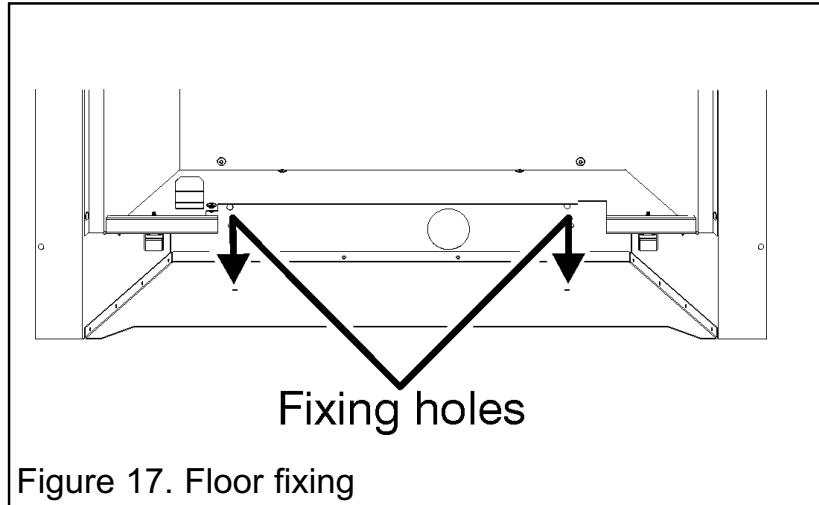

Figure 17. Floor fixing

The supply pipe must be rigid material. Flexible pipe must not be used. Connect the supply line to the appliance.

2. If closed, open the isolating valve at the inlet 'T' connector.
3. Turn on the gas supply and pressure check the installation pipework for gas soundness. In the United Kingdom (GB) check in accordance with the current edition of BS 6891. In the Republic of Ireland check in accordance with the current edition of IS 813 "Domestic Gas Installations".

Some burner operations can be checked at this stage. Checking now will mean that less disassembly will be required if any problems are found. **A full check should still be made, however, after final installation. Only leave the burner alight long enough to confirm its operation.**

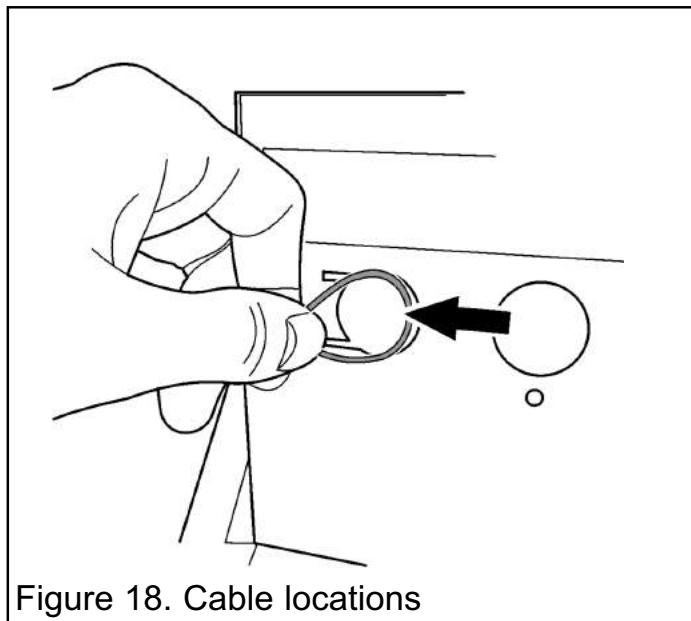



Figure 18. Cable locations

### 13.3 Burner checks.

#### 13.3.1 Lighting the fire.

If closed, open the isolating 'T' connector valve.

Turn the 'manual' knob to the ON, full counterclockwise  position.





# INSTALLER GUIDE

Simultaneously press and hold the 'OFF' and  (large flame) buttons until a short acoustic signal confirms the start sequence has begun; release buttons. Continuing signals confirms the ignition is in progress. There will be a slight delay and several sparks should be seen between the electrode and pilot tip. Once pilot ignition is confirmed there is main gas flow.



## ⚠ WARNING

When pilot ignition is confirmed, the motor turns automatically to maximum flame height.

### 13.3.2 Adjusting flame height.

When the burner is operating press the  (large flame) button to increase the flame height and press the  (small flame) to decrease the flame height. For fine adjustment press the  /  button for approximately two seconds until an acoustic signal is given, then release the button.

### 13.3.3 Adjusting to pilot only setting.

When the burner is operating press and hold the  (small flame) until the burner flame extinguishes. To turn the main burner on again simply press and hold the  (large flame) button.

### 13.3.4 Turning off.

To turn the fire off press the 'OFF' button.

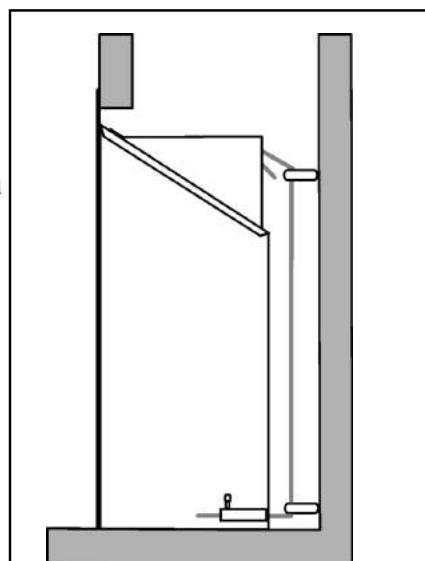

Figure 19. Cable route

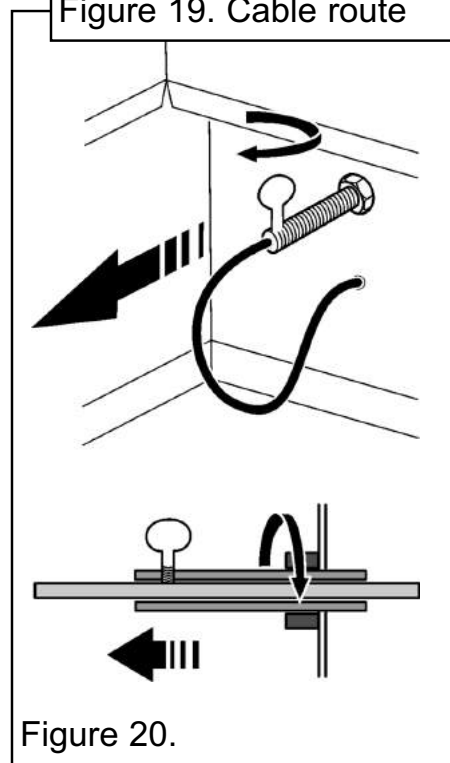

Figure 20.

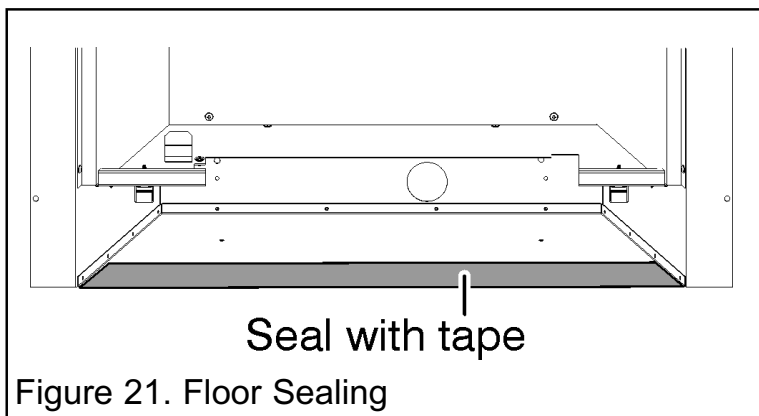

Figure 21. Floor Sealing

# INSTALLER GUIDE

## 13.4 Check inlet pressure.

The appliance is pre-set to give the correct heat input at the inlet pressure shown in section 4 of this guide. No adjustment is necessary.

1. Ensure that the fire is OFF then fit a pressure gauge at the test point. The test point is on the inlet 'T' connector (See figure 22). Turn the fire ON and check the pressure with the appliance alight and set at maximum output.
2. After checking, turn off the appliance. Remove the pressure gauge and replace the test point sealing screw.
3. Test around the sealing screw for gas soundness with a suitable leak detection fluid.

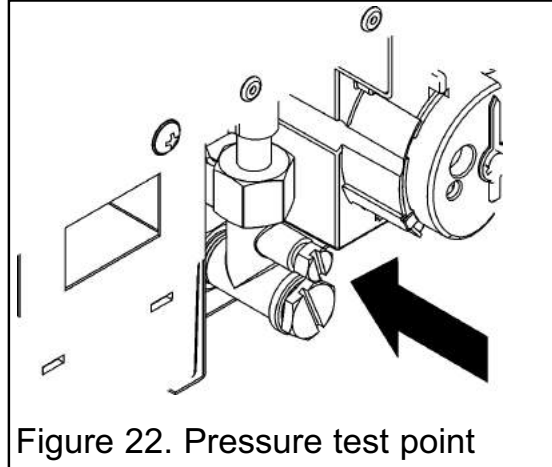

Figure 22. Pressure test point

## 14. FITTING THE CERAMIC FUEL EFFECT

Before continuing ensure that the burner is OFF. Wait a few minutes for the convection box and burner to cool completely. To prevent unexpected burner operation, it is advisable to either remove the batteries from the remote control handset or place the handset away from the work area and out of reach of children.

The ceramic walls have a plain and patterned side. Ask the customer which they prefer.

### 14.1 Fitting the rear ceramic wall.

Locate the rear ceramic wall against the rear wall of the convector box.

### 14.2 Fitting the side ceramic walls.

Offer the ceramic side walls into the convection box. The bottom of the ceramic side walls should be located first (See figure 23). With the bottom in place gently lift the side wall until it is flat against the side of the convection box (See figure 24).

### 14.3 Fitting the ceramic support.

Locate the ceramic support to the base of the burner tray using three No.8 x 3/8" screws supplied (See figure 24).

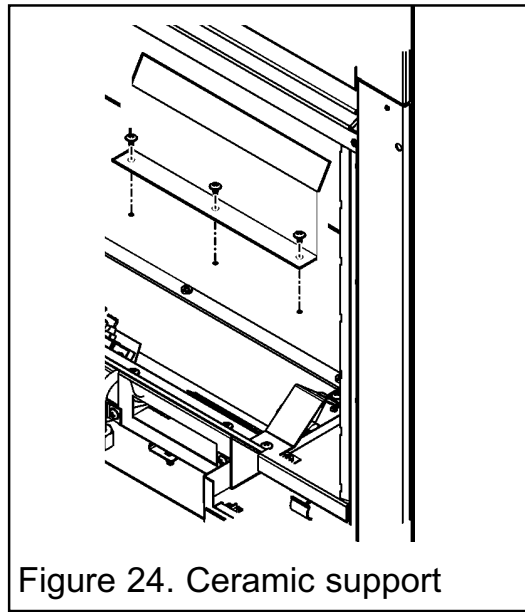
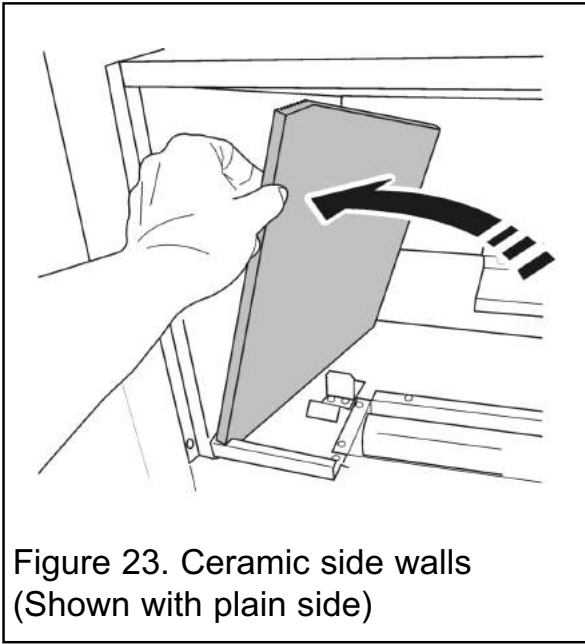

#### 14.4 Fitting the port cover.

The port cover supplied with the fire needs to be fitted to the inner top of the convection box. Locate the port cover, being careful not to scratch the ceramic side walls, and secure with three No. 8 x 3/8" screws supplied (See figure 25).

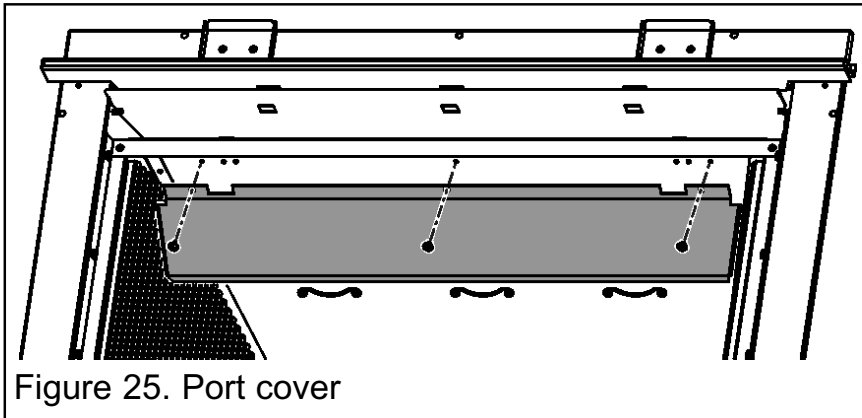

#### 14.5 Fitting the ceramic fuel effect.

The installer and owner guide for the ceramic fuel effect is supplied with the ceramic fuel effect. It is important that the fitting guide for the ceramic fuel effect be placed inside or attached to this guide and handed to the customer following completion of the 'Final review' section.

### 15.1 Check the burner operation.

Repeat the checks conducted in section 12.3.

*Please note:*

*When first turned on from cold, the flames will appear predominantly blue.*

*When operating the fire for the first time, some vapours may be given off which could set off smoke alarms in the vicinity. These vapours are quite normal with new appliances. They are totally harmless and will disappear after a few hours use.*

### 15.2 Check for spillage.

**A spillage check must be made before leaving the installed appliance with the customer.**

**The spillage check must be conducted before fitting the fascia.**

1. Close all doors and windows in the room containing the appliance.
2. Unscrew and remove the upper heat baffle (See figure 28). Place the heat baffle in a safe place away from the work area.
3. Light the appliance and set the control to its highest heat position.
4. Leave the appliance on for five minutes.
5. At the top of the heater are two openings. The upper opening has a tapered rear that has an opening of its own. The smoke match should be placed horizontally into this opening so that it touches the right hand side of the opening. It should pass the upper part of the opening by 40mm (See figure 28).

The installation is satisfactory if the smoke is drawn into the appliance.

If the smoke is not drawn into the appliance leave the appliance alight at the maximum setting for a further ten minutes and then repeat the test. If the smoke is still not drawn into the appliance inspect the sealing to the fireplace surround. If smoke is still not drawn into the appliance **disconnect the appliance and seek expert advice.**

6. If the above test is satisfactory open all internal connecting doors, hatches, etc. in the room. Keep all doors and windows that open to the outside of the building closed. Recheck for spillage as above. If an extractor fan is installed in the same room as the appliance or a connecting room, check that spillage does not occur with the fan operating and all doors and other openings between the fan and the appliance open. If the smoke is drawn into the appliance, continue with the installation. If the test is not satisfactory **disconnect the appliance and advise the customer of the cause of failure.**

7. Using the four screws removed previously, replace and secure the heat baffle in place.

# INSTALLER GUIDE

## 15.3 Flame supervision and spillage monitoring system.

This pilot unit includes a system that will automatically shut off the gas supply if the pilot flame goes out or if there is insufficient oxygen due to spillage or poor ventilation.

**This monitoring system must not be adjusted, bypassed or put out of operation.**

**This monitoring system or any of its parts must only be exchanged using Valor authorised parts.**

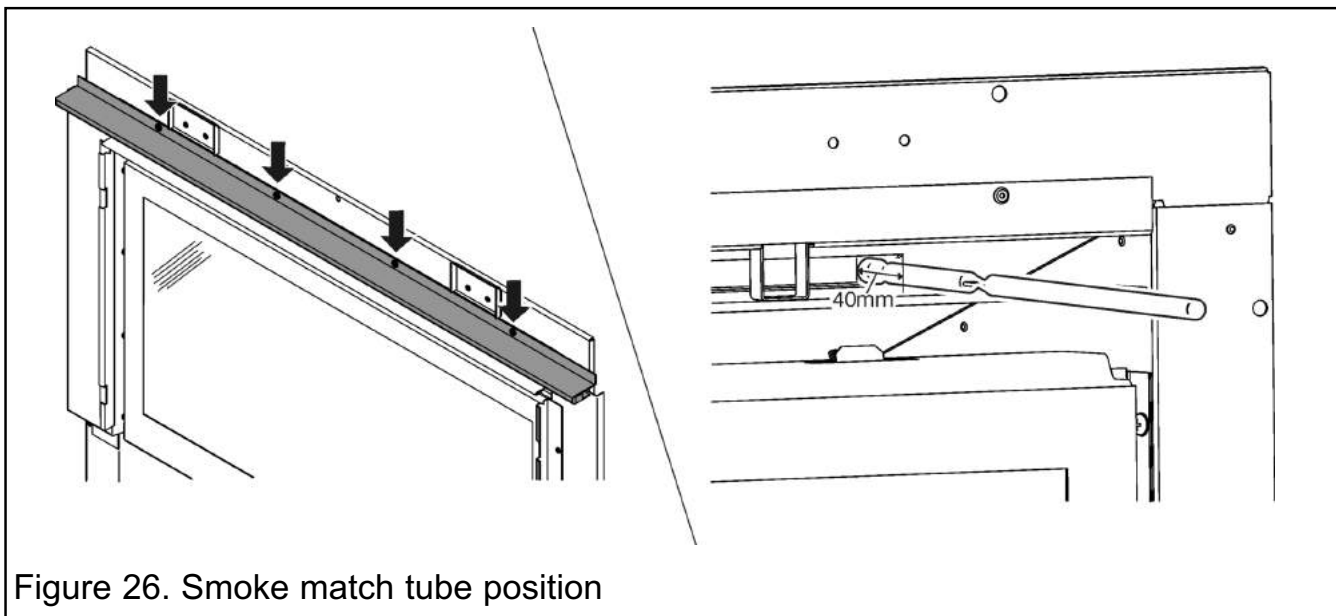



# INSTALLER GUIDE

## 1 6 0 FASCIA INSTALLATION

Blakely fascia - Refer to the two illustrations (See Fig 27) for guidance on the order in which the fascia components are assembled.

- Item A "Port Cover" should already be screw fixed in place as described in 14.4 (See Fig 25) inside the roof of the fire box.
- Item B "Outlet Baffle" is screw fixed using 4 screws across the top front of the convector box, this L shaped baffle must be mounted with the screws fixed above the horizontal flat section that protrudes out from the face of the engine.
- Item C "Window Panel" is hung onto the front of the engine and secured (Ref. Figs 6 & 7).
- Item D "Window Cover" is then placed hanging onto the top of Item C.
- Item E "Outer Frame" is fixed using 6 screws (supplied) onto the main engine, with Item F "Inner Frame" then secured by placing it into the outer frame Item E and releasing it down to slot in place.
- Item G "Fret" is secured by locating the two rear screws into the locating slots in Item F. There are two adjustable screws at the rear of the fret that can be adjusted to ensure the fret locates securely.

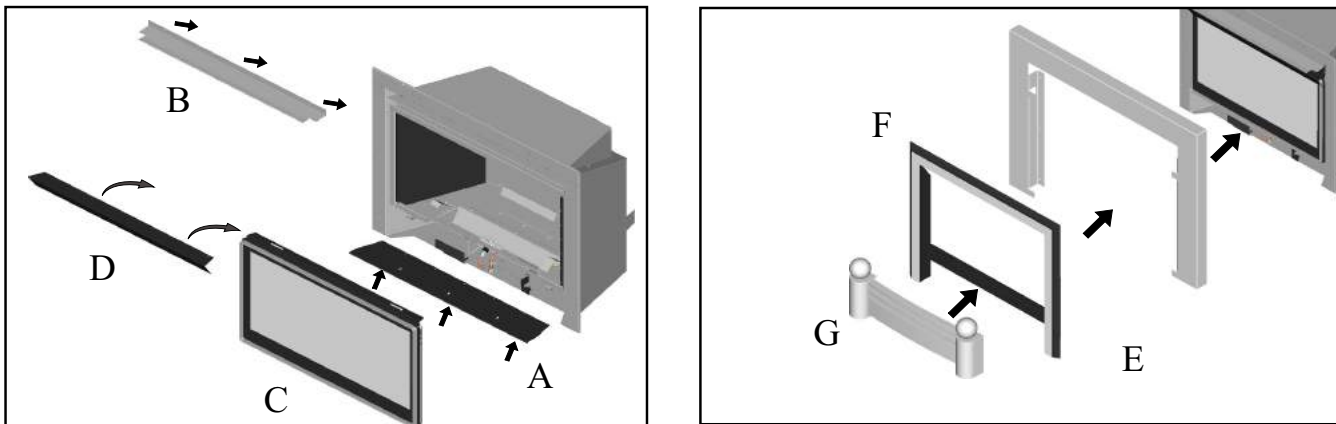

Fig 27 - Fitting Blakely fascia

# INSTALLER GUIDE

## FINAL REVIEW

- 1. COMPLETE THE INFORMATION IN THE WARRANTY AND SERVICE SECTION OF THE OWNER GUIDE (See last pages of the OWNER guide).**
2. Visually inspect the appliance. Clean off any marks incurred during installation.
3. Advise the customer how to operate the appliance. Point out that lighting instruction details are on the metal plate attached at the bottom of the appliance. Explain to the customer that the appliance has a flame failure & spillage monitoring system. Point out the explanation of this system shown in the owner guide under “Operating the fire”. Advise that if the fire goes out for any reason, wait at least three minutes before relighting. Stress that if the monitoring system repeatedly shuts off the fire, the appliance should be switched off and a specialist should be consulted.
4. Advise the customer that they should read their owner guide before operating the fire and always follow the advice in the section headed “Cleaning your fire”.
- 5. Stress that no extra ceramic fuel effect pieces must be added over and above those supplied with the appliance and that any replacements must only be the authorised spares. Warn that ignoring this advice could cause incomplete clearance of the products of combustion with consequent health hazards. If you have not done so already; attach or place the ceramic fuel effect guide inside this guide.**
6. Advise the customer that the appliance will operate to its maximum potential if the flue is primed during the first 20 – 30 minutes of use. To do this, simply set the control to its highest setting. This will also burn off any carbon deposits that may have formed during previous use.
- 7. Emphasise that if the glass panel is broken or damaged, the fire should be turned off and not used until the window unit is refitted with an authorised replacement. The fire should not be used without the glass panel fitted.**
8. Advise the customer that when first turned on from cold, the flames will appear predominantly blue and it is normal for condensation to form on the rear of the glass panel. The condensation will disappear after a few minutes use.
9. If using the appliance for long periods it is beneficial to change between settings. This will also help to remove any carbon deposits that may form during use.
10. Recommend that the appliance should be serviced by a competent person at least annually.
11. If the appliance is in premises in the United Kingdom occupied by a tenant, point out that by law a landlord must have any gas appliance, flue and pipework which is situated in a tenant’s premises checked for safety at least every 12 months.
12. Advise that the fire may give off a slight odour while new. This is quite normal and it will disappear after a short period of use.
- 13. Inform the customer that the Serial number for the appliance is located on the information label, located behind the fascia and underneath the burner module (See last page of the owner guide for illustration).**
14. Hand the literature pack with this guide to the customer.

# INSTALLER GUIDE

## 13. SERVICING & PARTS REPLACEMENT

- Always turn off the gas supply before commencing any servicing and allow the fire to cool completely (The appliance inlet 'T' connector incorporates an isolating valve).
- It is recommended that, at least once a year, the appliance is disconnected and the fireplace opening checked and cleared of any debris.
- This product uses fuel effect pieces, burner compartment walls and ceramic gravel containing Refractory Ceramic Fibres (RCF), which are man-made vitreous silicate fibres. Excessive exposure to these materials may cause irritation to eyes, skin and respiratory tract. Consequently, it is important to take care when handling these articles to ensure that the release of dust is kept to a minimum. To ensure that the release of fibres from these RCF articles is kept to a minimum, during installation and servicing we recommend that you use a HEPA filtered vacuum to remove any dust and soot accumulated in and around the fire before and after working on the fire. When replacing these articles we recommend that the replaced items are not broken up, but are sealed within a heavy duty polythene bag, clearly labelled as RCF waste. RCF waste is classed as a stable, non-reactive hazardous waste and may be disposed at a landfill licensed to accept such waste. Protective clothing is not required when handling these articles, but we recommend you follow the normal hygiene rules of not smoking, eating or drinking in the work area and always wash your hands before eating or drinking.
- Check that the appliance is clean and that soot or debris is not blocking the gaps between the ceramic fuel effect pieces causing an imperfect flame.
- Check that soot or debris is not impairing the electrode spark or pilot burner.
- Check that soot or debris is not blocking any of the slots in the main burner.
- After servicing, make sure that the ceramic walls are replaced and the ceramic fuel effect pieces are replaced correctly as described in the installer and owner guide supplied with the ceramic fuel effect. The ceramic fuel effect guide may have been placed inside or attached to this guide.
- **Always test for gas soundness and spillage after servicing the appliance.**
- **We recommend that the batteries in the receiver box are changed during servicing.**

# INSTALLER GUIDE

## 18.1 Checking the aeration setting of the burner.

1. The aeration shutter is factory set. It is important to ensure that the aeration setting is correct (See figure 28).
2. If the setting is not as shown in figure 28 adjust the aeration setting. To do this loosen the two aeration shutter screws, slide the aeration shutter to the desired position and tighten the screws.

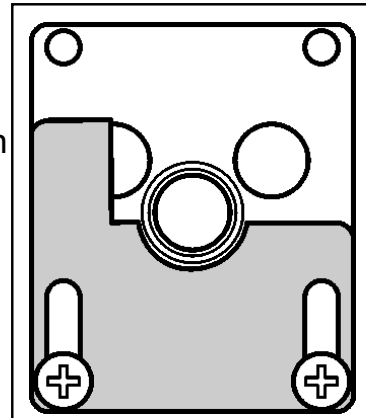

Figure 28. Aeration shutter setting.

## 18.2 To remove the window panel.

1. The window panel is secured at the bottom with two clamps. To release the clamps, hold at the rear and pull down (See figure 29).
2. With both clamps released, gently pull the base of the window panel forward. Hold the window panel base and lift upward until clear of the two upper window retainers (See figure 30).
3. Replace in the reverse order.

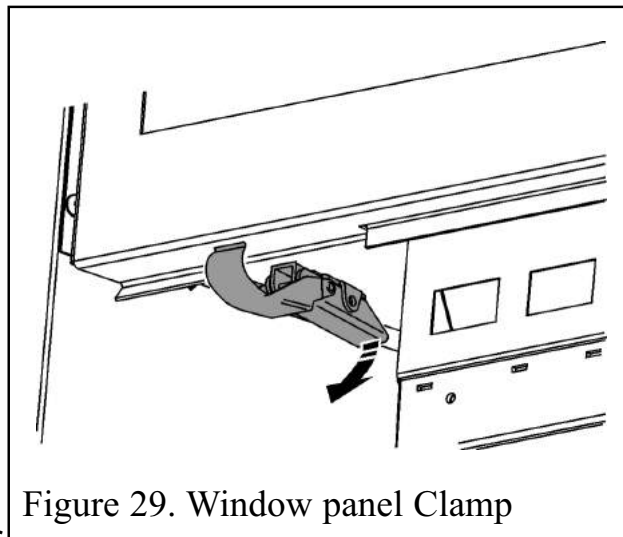

Figure 29. Window panel Clamp

## 18.3 To remove the fuel effect.

1. Remove the fuel effect in the reverse order to that shown for fitting in the ceramic guide. The ceramic fuel effect may cause staining / discolouration to decorative surfaces. It is therefore advisable to protect decorative surfaces.
2. Replace in the reverse order.

## 18.4 To remove the ceramic side walls.

1. Support the upper port cover, then unscrew and remove the three securing screws (See figure 26). Gently remove the port cover ensuring that the side ceramic side walls are not scratched.
2. Gently lower the top of the ceramic side wall towards the burner being careful not to catch the bottom on the burner brackets. Lift the side walls clear of the convection box.
3. Replace in the reverse order.

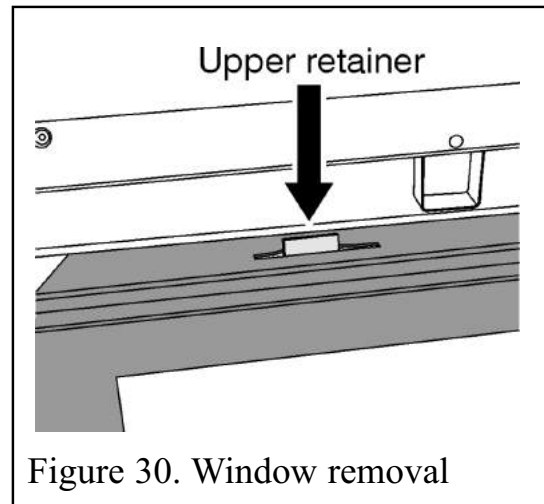

Figure 30. Window removal

# INSTALLER GUIDE

## 18.5 To remove the burner unit.

1. Complete section 18.4.
2. Isolate the gas supply at the inlet isolating 'T' connector.
3. Support the inlet 'T' connector to avoid straining the pipework and disconnect the appliance from the inlet 'T' connector.
4. Unscrew and remove the seven screws from the top of the burner (See figure 31).
5. Slide the burner unit clear of the support tray.
6. Replace in the reverse order.

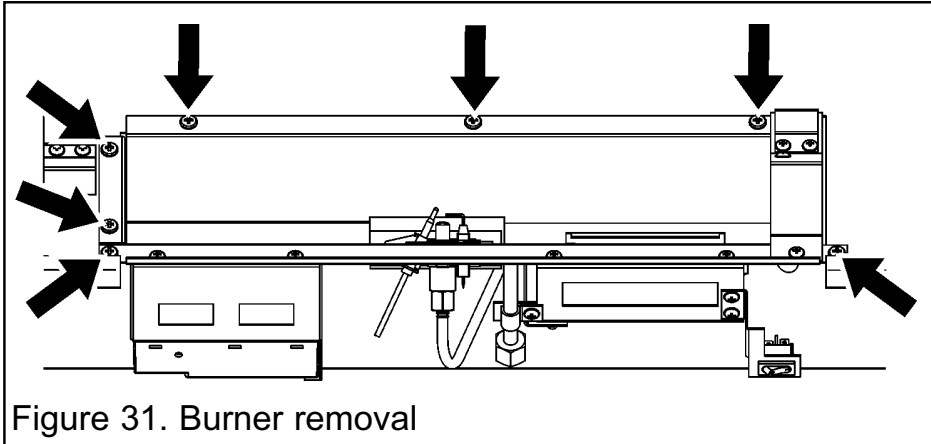

Figure 31. Burner removal

## 18.6 To remove the pilot unit.

1. Remove the burner assembly (See section 18.5).
2. Detach the pilot pipe from the pilot unit.
3. Detach the electrode lead from the underside of the electrode tab.
4. Detach the thermocouple by unscrewing the thermocouple nut at the interrupter block (See figure 31).
5. Remove the two screws from the pilot bracket (See figure 32).
6. Remove the pilot bracket and pilot assembly.
7. Remove the two screws securing the pilot unit to the bracket.
8. Refit in the reverse order.

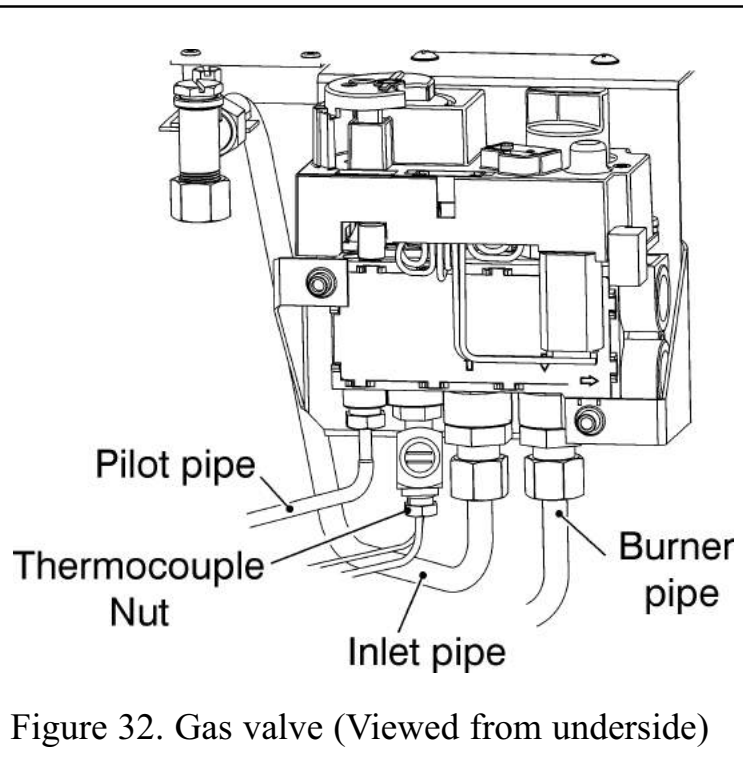

Figure 32. Gas valve (Viewed from underside)

*Note: The pilot unit is an atmosphere sensing device. It must be replaced as a whole assembly. Its individual components are not separately replaceable.*

## INSTALLER GUIDE

### 18.7 To remove the gas valve.

(See figure 32).

1. Remove the burner assembly (See section 18.6).
2. If turning the burner upside down, ensure that the work surface is suitably protected. This will avoid damage to the work surface.
3. Remove the thermocouple by unscrewing the thermocouple nut at the interrupter block. Remove the two leads from the interrupter block making sure to pull on the base of the tabs and not the leads. It is important that when replacing the leads that the lead with the larger tag (From the receiver) is furthest away from the valve body.
4. Detach the pilot pipe from the gas valve.
5. Detach the inlet pipe.
6. Detach the burner pipe.
7. Detach the electrode lead from the base of the electrode.
8. Remove the wiring block from the front of the valve. To do this press the retainer tab on the base of the valve (See figure 34) whilst gently pulling on the leads.
9. Remove the two screws that hold the On/Off switch bracket to the front of the gas valve bracket (See figure 35).
10. Remove the two screws that retain the gas valve bracket from the front of the burner tray and lift the bracket and gas valve assembly clear.
11. Remove the two screws securing the gas valve to the mounting bracket.
12. Remove the gas valve.
13. Refit in the reverse order.

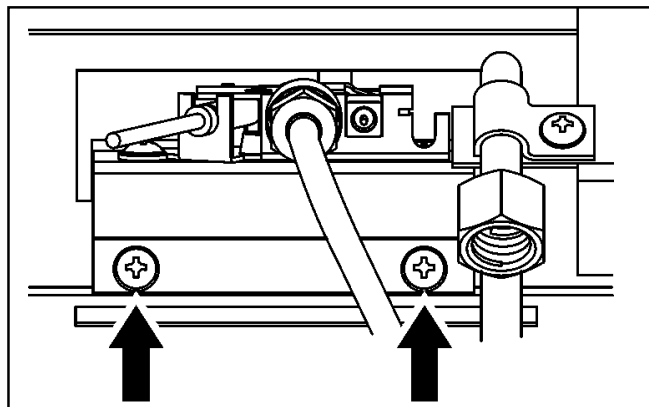

Figure 33. Pilot / pilot bracket assembly removal

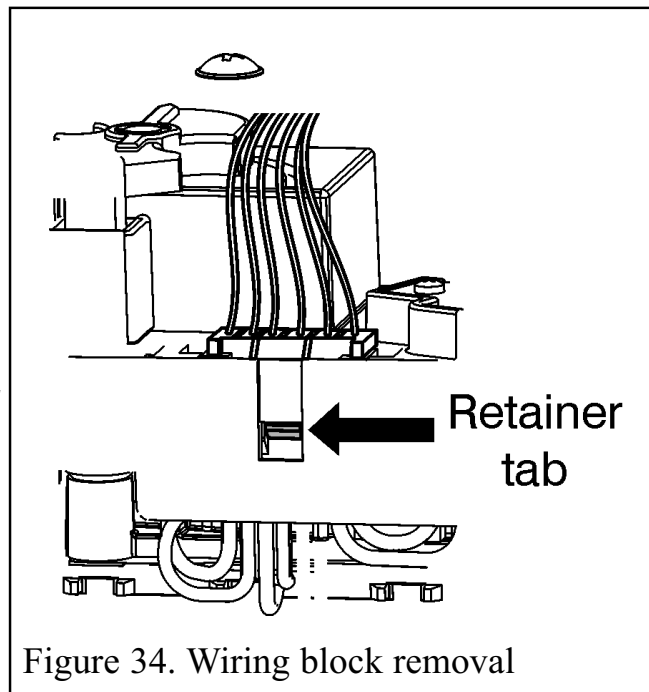

Figure 34. Wiring block removal

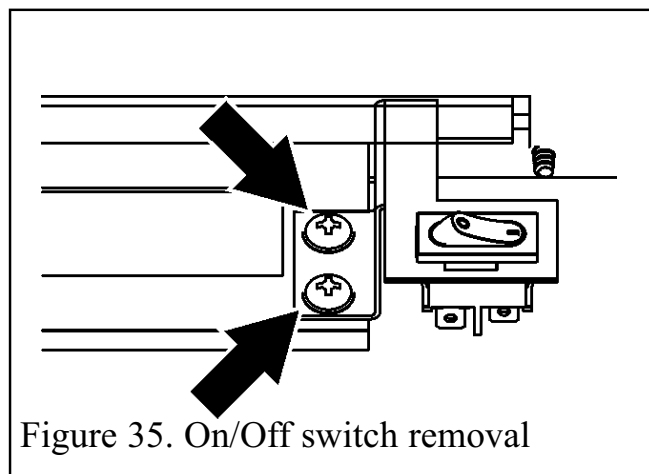

Figure 35. On/Off switch removal

# INSTALLER GUIDE

## 18.8 To remove the receiver box.

1. Slide the receiver box out of its support bracket.
2. Remove the electrode 'SPARK' lead.
3. Remove the wiring block from the side of the receiver box.
4. Unscrew and remove the yellow coded switch wire and red coded thermocouple wire.
5. Refit in reverse order. Please note that the yellow and red wire positions are marked with coloured spots on the valve body.

## 18.9 To remove the thermocouple interrupter block.

(See figure 32).

1. Remove the burner unit (See section 18.6).
2. Detach the thermocouple from the interrupter block by unscrewing the thermocouple nut.
3. Detach the two leads from the interrupter block making sure to pull on the base of the tabs and not the leads. It is important that when replacing the leads that the lead with the larger tag (From the receiver) is furthest away from the valve body.
4. Remove the interrupter block by unscrewing from the gas shut-off tap.
5. Refit in the reverse order. If the leads cannot be easily attached to the interrupter block when it is fully tightened to the gas shut-off tap, slacken it and rotate to allow the leads to be fitted. Retighten making sure that the leads remain in place in the interrupter block. Fit and tighten the thermocouple nut making sure that the leads are secured in the interrupter block to give a good electrical contact. Do not over tighten the thermocouple nut.

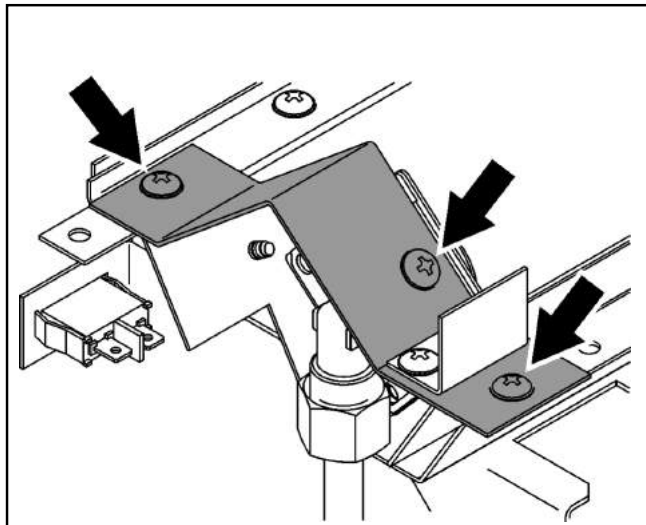

Figure 36. Burner clamping plate

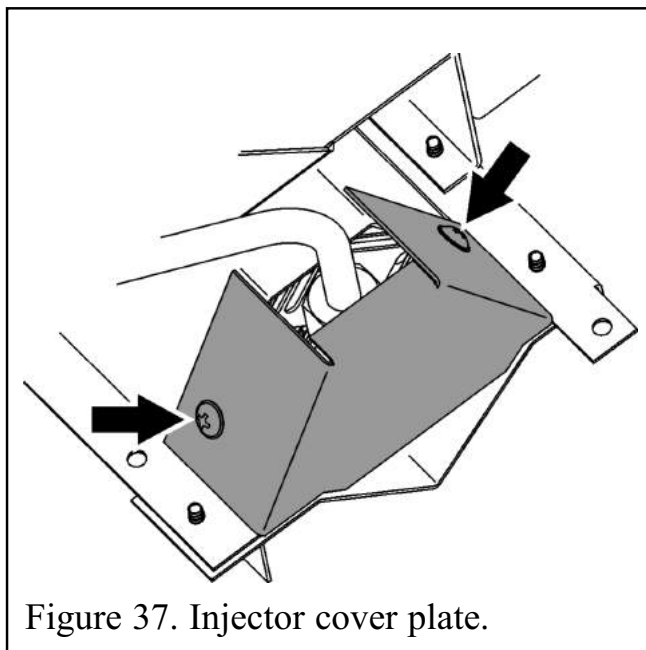

Figure 37. Injector cover plate.

## 18.10 To replace the burner.

1. Remove the burner unit (See section 18.6).
2. Unscrew and remove the burner clamping plate from the upper right hand side of the burner. Remove all three screws for ease (See figure 36).
3. Unscrew and remove the injector cover plate from underneath the burner (See figure 37).

# INSTALLER GUIDE

4. Support the elbow injector and unscrew the injector nut.
5. Lift the right hand side of the burner, slide it to the right and lift clear
6. Refit in reverse order.

## 18.11 To remove the burner injector.

1. Remove the burner (See section 18.11 points 1-5).
2. Unscrew the injector from the burner.
3. Refit in the reverse order.

## 18.12 To remove the appliance from the fireplace.

1. Follow steps 18.2 - 18.5.
2. Detach the burner unit and support tray from the convection box by removing six screws (See figure 38). Lift the burner unit clear.
3. If the fire retention is as method 1 (See section 12.1 of this guide), remove the screws.  
If the fire retention is as method 2 (See section 12.2 of this guide), slacken the hexagonal adjusters on the cable retainers and unscrew the thumbscrews to release the cables.
4. Refit as described in the relevant installation sections. Make sure gas soundness, sealing, spillage test and performance are satisfactory.

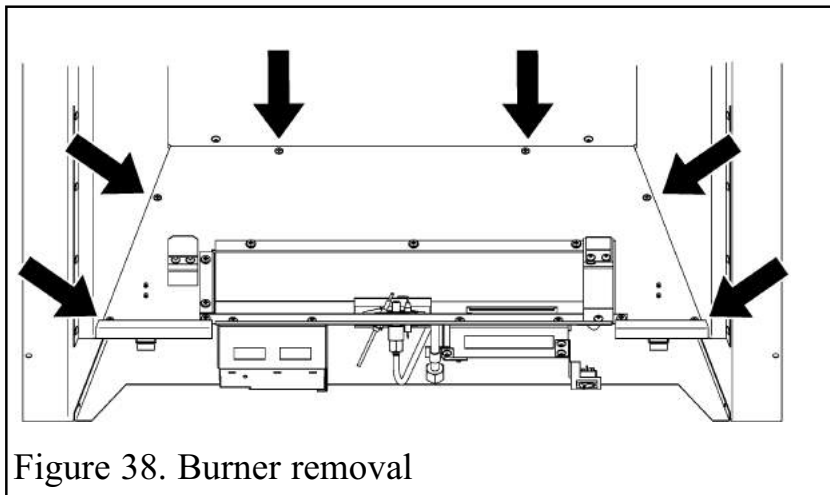



# OWNER GUIDE

FOR WARRANTY AND SERVICE INFORMATION  
SEE PAGES 55 TO 58

# OWNER GUIDE

## LIST OF CONTENTS

<u>Section</u>	<u>Page</u>
<b>SAFETY</b>	<b>43</b>
<b>GAS CONSUMPTION</b>	<b>44</b>
<b>APPLIANCE DIMENSIONS</b>	<b>45</b>
<b>OPERATING YOUR FIRE</b>	<b>46</b>
The Oxysafe flame sensing and flue blockage safety system.	46
Operating the fire WITH the Remote Control Handset.	46
Lighting the fire.	46
Adjusting the flame height.	46
Adjusting to the pilot only setting.	47
To turn off.	47
Operating the fire WITHOUT the Remote Control Handset.	48
Lighting the burner in the event of battery failure.	48
<b>CLEANING YOUR FIRE</b>	<b>49</b>
Metal and painted parts.	49
Fascia	49
Removing and cleaning the window assembly.	49
Ceramic fuel effect pieces and burner compartment walls.	52
Burner	52
<b>MAINTENANCE</b>	<b>53</b>
Battery replacement.	53
Handset.	53
Receiver box.	53
Regular maintenance.	54
Replacement ceramics.	54
<b>WARRANTY AND SERVICE</b>	<b>55</b>

This gas fire is designed to meet the most stringent quality, performance and safety requirements to provide you with many years' trouble-free service.

This guide aims to improve your understanding and appreciation of your gas fire by providing simple and informative instructions to ensure that you benefit from the excellent performance and features it has to offer.

### IF YOU SMELL GAS

- **DON'T SMOKE.**
- **EXTINGUISH ALL NAKED FLAMES.**
- **DON'T TURN ELECTRICAL SWITCHES ON OR OFF.**
- **TURN OFF THE GAS SUPPLY AT THE METER OR TANK AS APPROPRIATE.**
- **OPEN DOORS AND WINDOWS TO GET RID OF THE GAS.**
- **IMMEDIATELY CALL THE GAS EMERGENCY SERVICE FROM A NEIGHBOURS PHONE - SEE YOUR LOCAL TELEPHONE DIRECTORY.**

**Do** have the fire installed by a competent person. In the United Kingdom, installation must be in accordance with the latest edition of the Gas Safety (installation & use) Regulations. In the Republic of Ireland, installation must be in accordance with all national and local regulations in force.

**Do** have the chimney swept prior to installation if it was previously used for solid fuel.

**Do** have the fire installed in accordance with the installation instructions.

**Do** wait three minutes before attempting to relight if the fire is switched off or the flames are extinguished for any reason. (Your fire is fitted with a safety device that will automatically shut off the gas supply to the fire if, for any reason, the flames go out).

**Do** provide the minimum height from the base of the fireplace opening to the underside of any shelf made from wood or other combustible materials is detailed below.

- *For a shelf up to 150mm deep: Minimum height = 750mm.*
- *For a shelf deeper than 150mm: 750mm + 12.5mm for every 25mm depth over 150mm (See figure 1).*

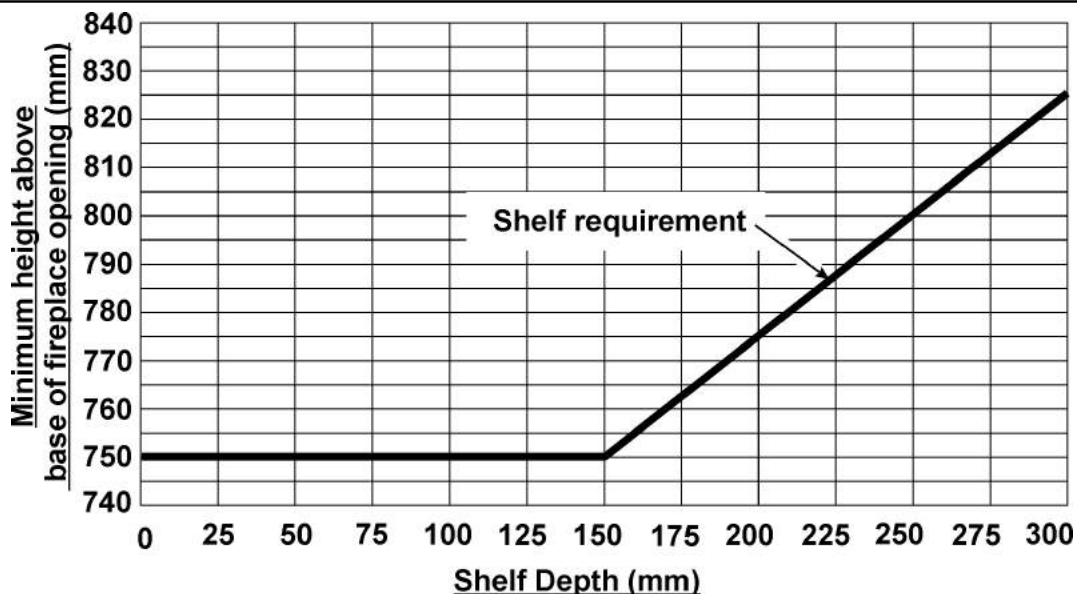

Figure 1. Combustible shelf clearances

## OWNER GUIDE

**Do** get advice about the suitability of any wall covering near your fire. Soft wall coverings (e.g. embossed vinyl, etc.) which have a raised pattern are easily affected by heat. They may, therefore, scorch or become discoloured when close to a heating appliance. Please bear this in mind whenever you are considering redecorating.

**Do** provide a minimum side clearance as detailed in figure 2. Please bear this in mind if ever you are considering altering the room.

**HOT - Do provide a suitable guard that complies with BS 8423 for the protection of young children, the elderly, the infirm and pet animals.**

**Don't** hang clothing, towels or any other fabrics over the fire.

**Don't** add any ceramic fuel effect pieces to the burner. This could cause incomplete combustion and safety hazard.

**Don't** put paper or any other material on the fire.

**Don't** place any combustible material (rugs, carpet, plastic tiles, etc.) on the hearth.

**Don't** attempt to clean or service the fire until it has been switched off and allowed to cool completely.

**NOTE:** The Blakely appliance only is supplied with a flue restrictor, this should have been fitted if the flue height is greater than 4.3m (14ft), with a good draught present. Generally we recommend the flue restrictor is not fitted to precast flues or metal flue box installations. There may be circumstances where fitting the restrictor causes the fire to fail the spillage test, in such cases the restrictor will have been removed by your installer.

## GAS CONSUMPTION

### Natural Gas

Has a maximum natural gas input of 5.7kW (Gross)

Has a maximum natural gas output of 4.31kW

Has a minimum natural gas input of 2.0kW (Gross)

Has a minimum natural gas output of 1.33kW

### LPG

Has a maximum LPG input of 5.6kW (Gross)

Has a maximum LPG gas output of 4.23kW

Has a minimum LPG gas input of 3.3kW (Gross)

Has a minimum LPG gas output of 2.37kW

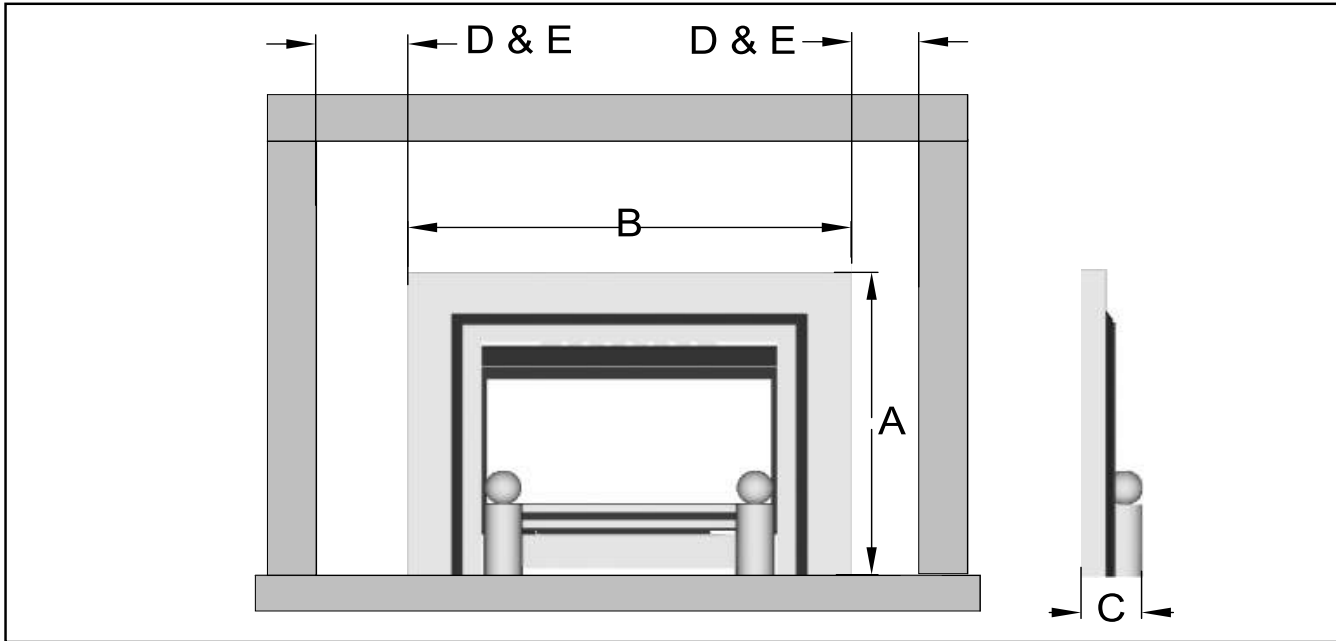

Key	Description	Blakely Model
A	Height (mm)	680
B	Width (mm)	930
C	Depth into room (mm)	130
D	Minimum <b>mandatory</b> clearance to <b>combustible</b> surfaces projecting beyond the front of appliance (mm)	75
E	<b>Recommended</b> clearance to <b>non-combustible</b> surfaces for access purposes (mm)	50

Figure 2. Blakely appliance dimensions and clearances (Dimensions are subject to manufacturing tolerances)

### PLEASE NOTE

When operating your fire for the first time, some vapours may be given off which may cause a slight odour and could possibly set off any smoke alarms in the immediate vicinity. These vapours are quite normal with new appliances. They are totally harmless and will disappear after a few hours use.

### The Oxysafe flame sensing and flue blockage safety system.

For your safety, this appliance is fitted with a flue blockage safety device which is designed to shut down the appliance in the event of abnormal flue conditions.

**NOTE - This device is NOT a substitute for an independently mounted Carbon Monoxide detector. We recommend the use of a fully approved CO detector.**

The device is designed to also automatically shut off the gas supply to the fire if the pilot flame goes out due to lack of oxygen or for any other reason.

**If this device starts to repeatedly shut off the gas, get expert advice.**

This device incorporates a probe which senses that the heat from the pilot flame is correct. If this probe is cool, the device will prevent any gas flow unless the control knob is held in at the ignition position.

If, for any reason, the flames go out when the fire is hot or if the fire is turned off when hot, always **wait at least three minutes before attempting to relight.**

### Operating the fire WITH the Remote Control Handset.

#### Lighting the fire.



Turn the 'manual' knob to the ON, full counterclockwise  position.

Simultaneously press and hold the 'OFF' and  (large flame) buttons until a short acoustic signal confirms the start sequence has begun; release buttons. Continuing signals confirms the ignition is in progress. There will be a slight delay and several sparks should be seen between the electrode and pilot tip. Once pilot ignition is confirmed there is main gas flow.

### WARNING

When pilot ignition is confirmed, motor turns automatically to maximum flame height.

#### Adjusting the flame height.

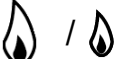

When the burner is operating press the  (large flame) button to increase the flame height and press the  (small flame) to decrease the flame height. For fine adjustment press the  button for approximately two seconds until an acoustic

signal is given, then release the button.

Please note:

- The flames on the N.G. appliance will appear predominantly blue. The flames on the L.P.G. appliance will appear predominantly yellow.
- The appliance will operate to its maximum potential if the flue is primed during the first 20 – 30 minutes of operation. To do this, simply set the control knob to its 'HIGH' setting. This will also burn off any dust deposits that may have formed during the appliance being switched off.

## Adjusting to the pilot only setting.

When the burner is operating press and hold the  (small flame) until the burner flame extinguishes. The pilot can be seen through the cutout immediately to the right of the centre log (See figure 3). To turn the main burner on again simply press and hold the  (large flame) button.

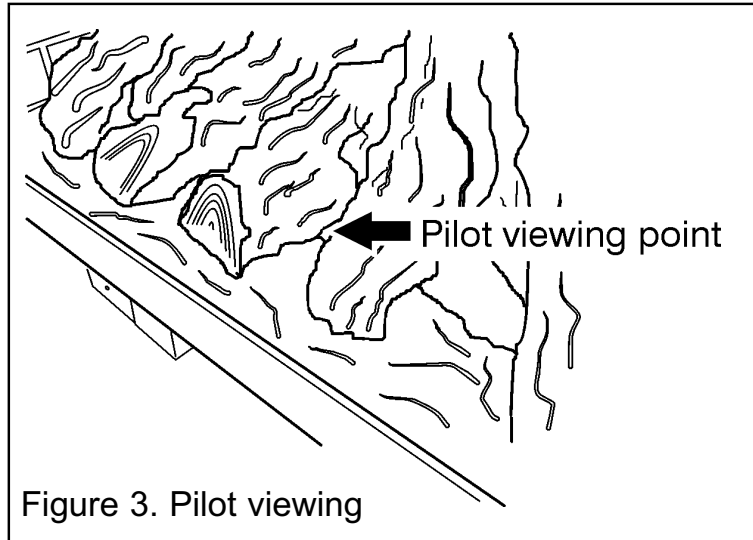

Figure 3. Pilot viewing

## To turn off.

To turn the fire off press the 'OFF' button. After turning the fire off the remote control valve will return to its starting position. For this reason it is important to leave the appliance alone for a period of one (1) minute before attempting to relight.

## Operating the fire WITHOUT the Remote Control Handset.

### Lighting the burner in the event of battery failure.

1. To gain access to the gas valve it will be necessary to remove the fascia. **Please read the SAFETY section at the start of the installer guide.** The bottom of the fascia is held in place with magnets. Hold the lower outside edges of the fascia and gently pull forward. With the bottom released, lift the fascia upward and clear of the upper hanging brackets on the convection box.

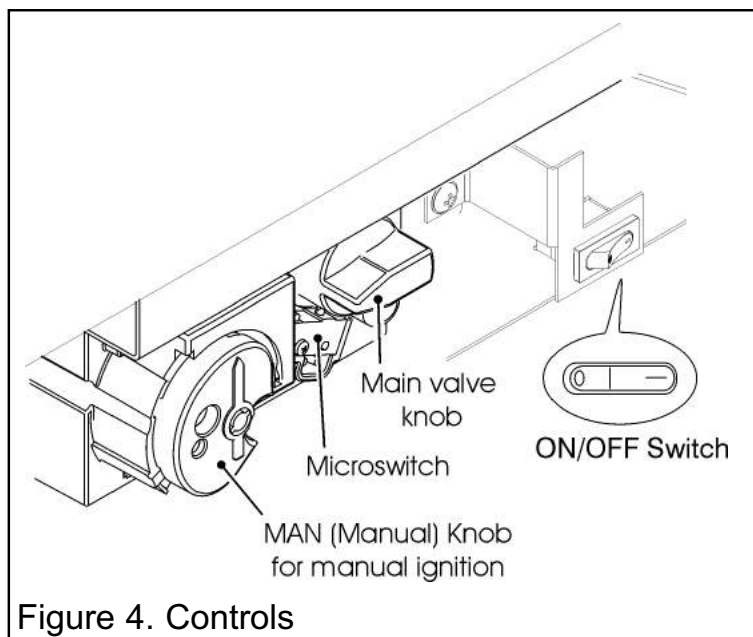



Figure 4. Controls

## OWNER GUIDE

- The 'main valve knob' is the knob on the right hand side (See figure 4). Turn this knob to the 'OFF', fully clockwise position .
- The 'manual knob' is the knob on the left hand side (See figure 5). Turn this knob to the 'OFF', fully clockwise  position.
- Place the 'ON/OFF' switch to the 'O' (Off position).
- Wait five (5) minutes to clear out any gas. Then smell for gas, including near the floor. If you smell gas STOP! and follow the safety information below.

- DON'T SMOKE.
- EXTINGUISH ALL NAKED FLAMES.
- DON'T TURN ELECTRICAL SWITCHES ON OR OFF.
- TURN OFF THE GAS SUPPLY AT THE METER OR TANK AS APPROPRIATE.
- OPEN DOORS AND WINDOWS TO GET RID OF THE GAS.
- IMMEDIATELY CALL THE GAS EMERGENCY SERVICE FROM A NEIGHBOURS PHONE - SEE YOUR LOCAL TELEPHONE DIRECTORY.

If you do not smell gas, proceed as below:

6. Place the 'ON/OFF switch to the '-' (On position).

7. With the 'manual' knob in 'MAN' position a manual pilot valve operator is accessible (See figure 5).

- Fully push down the manual pilot valve operator using the end of a pencil or similar and hold in to start pilot gas flow. Immediately light the pilot with a long match held at 45° at the left hand side of the pilot (See figure 6), while continuing to hold in the manual pilot valve operator for about ten (10) seconds after the pilot is lit. Release manual pilot valve operator. If pilot does not stay lit, repeat steps 2 through 7.

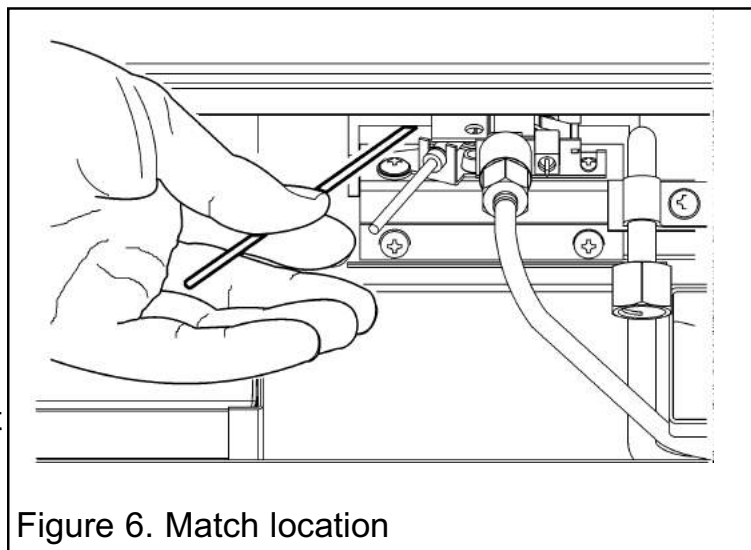
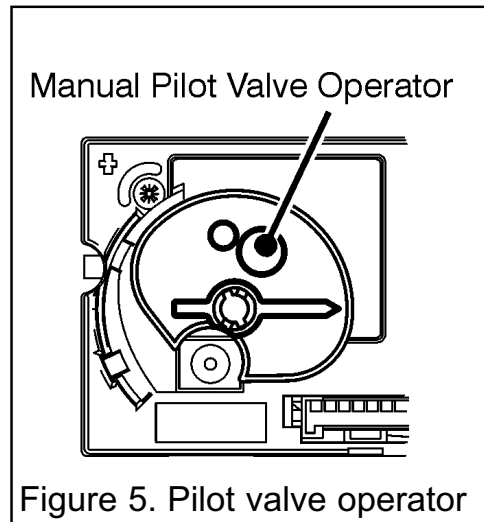

**NOTE** If the pilot does not stay lit after several tries, turn the gas control knob (main valve knob) to 'OFF' and proceed to step 10.



## OWNER GUIDE

8. Turn the 'manual' knob to the ON, full counterclockwise  position. The main burner will now light on the max flame setting.

9. Turn main valve knob to the full 'ON' counterclockwise  position.

10. If the appliance will not operate, follow the instructions "To Turn Off" below and call the Valor Technical Helpline **0844 8711 554**.

### To turn off.

To turn the fire off press the 'ON/OFF' switch to the 'O' (Off position).

## CLEANING YOUR FIRE

To maintain the high performance and quality finish of your fire please follow these guidelines:

- Before attempting to clean the fire, please remember to turn off the fire and wait for the appliance to cool completely. The fire will retain heat for some time before cleaning can begin.
- If any pieces of debris are found in the convector box, have the chimney inspected before further use.

### Metal and painted parts.

- Clean the metal and painted parts with a slightly damp, lint free non-abrasive cloth and then dry.
- Do **not** use abrasive cleaners, as these will scratch the fire surface.

### Fascia.

- DO wipe any spills off immediately to limit possibility of staining.
- DO clean dust down regularly with a soft, clean brush and occasionally wipe over with a soft damp cloth.
- DO NOT use abrasive cleaners.
- DO NOT allow any acids or oils to come in contact with the fascia (This includes cleaning solutions, vinegar, lemon juice, candle wax etc.).
- DO NOT allow prolonged exposure to water.

### Removing and cleaning the window assembly.

Removal of the window assembly is only necessary if you wish to clean the rear of the window or access the ceramic components. The window assembly can be cleaned with a mild detergent and water. Glass cleaner can also be used. Any stains on the glass can be removed with a non-abrasive cleaner such as a ceramic hob cleaner. Never use abrasive cleaners. Clean the window carefully in accordance with the instructions supplied with the cleaner.

**Before removing the fascia please read the following guide to manual handling. This fascia is heavy. We therefore recommend that you use assistance if required.**

# OWNER GUIDE

- When lifting always keep your back straight. Bend your legs and not your back.
- Avoid twisting at the waist. It is better to reposition your feet.
- Avoid upper body/top heavy bending. Do not lean forward or sideways whilst handling the fascia.
- Always grip with the palm of the hand. Do not use the tips of fingers for support.
- Always keep the fascia as close to the body as possible. This will minimise the cantilever action.
- Use gloves to provide additional grip.
- Always use assistance if required.

**1.** The bottom of the fascia is held in place with thumbscrews. Unscrew and remove the thumbscrews from the perforated panel. Hold the lower outside edges of the fascia and gently pull forward. Lift the fascia upward and clear of the upper hanging brackets on the convection box.

**2.** The window panel is secured at the bottom with two clamps. To release the clamps, hold at the rear and pull down (See figure 7).

**3.** With both clamps released, gently pull the base of the window panel forward. Hold the window panel base and lift upward until clear of the two upper window retainers (See figure 8).

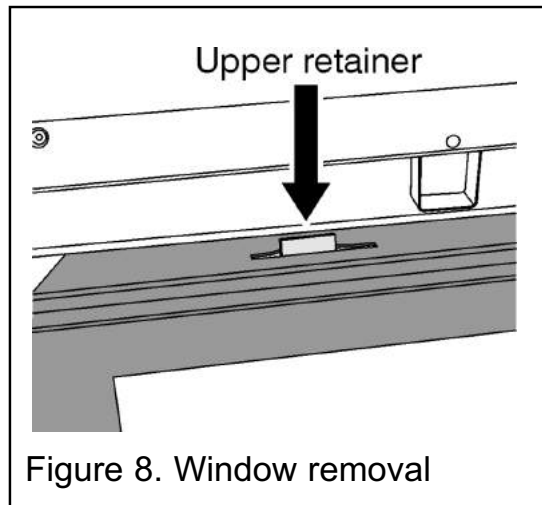
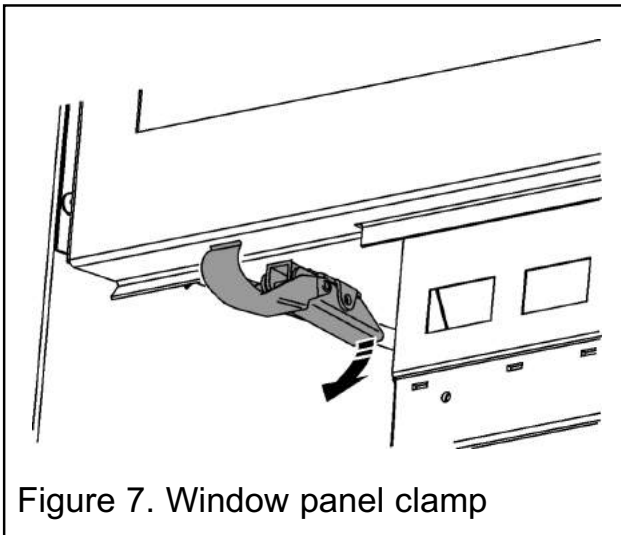

# OWNER GUIDE

4. Keeping the lower part of the inner trim clear of the window locate the upper edge into the slots at the top of the window side trims (See figure 10). The inner trim has slots in its rear, ensure that these locate onto the window trim. Lower the inner trim until it is retained by the magnets at the base of the window side trims.

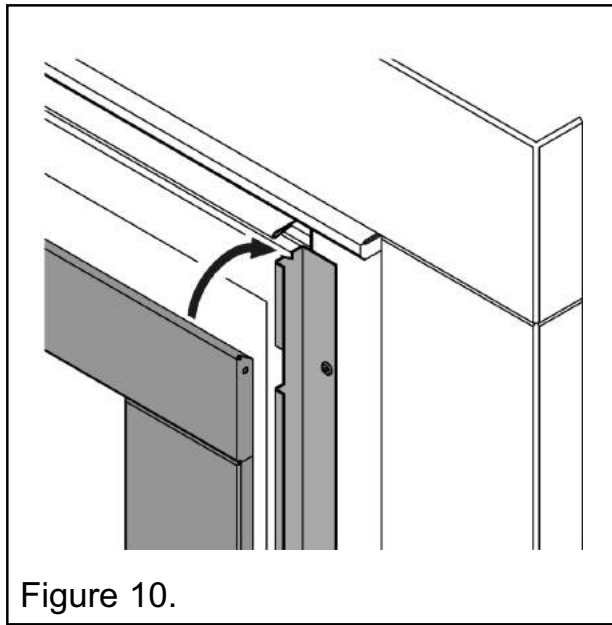

Figure 10.

5. Blakely fascia - Refer to the two illustrations (See Fig 9) for guidance on the order in which the fascia components are assembled.

- Item A "Port Cover" should already be screw fixed in place as described in 14.4

(See Fig 25, Installer Guide) inside the roof of the fire box.

- Item B "Outlet Baffle" is screw fixed using 4 screws across the top front of the convector box, this L shaped baffle must be mounted with the screws fixed above the horizontal flat section that protrudes out from the face of the engine.

- Item C "Window Panel" is hung onto the front of the engine and secured (Ref. Figs 7 & 8).

- Item D "Window Cover" is then placed hanging onto the top of Item C.

- Item E "Outer Frame" is fixed using 6 screws (supplied) onto the main engine, with Item F "Inner Frame" then secured by placing it into the outer frame Item E and releasing it down to slot in place.

- Item G "Fret" is secured by locating the two rear screws into the locating slots in Item F. There are two adjustable screws at the rear of the fret that can be adjusted to ensure the fret locates securely.

**Figure 9. Blakely fascia fitting**

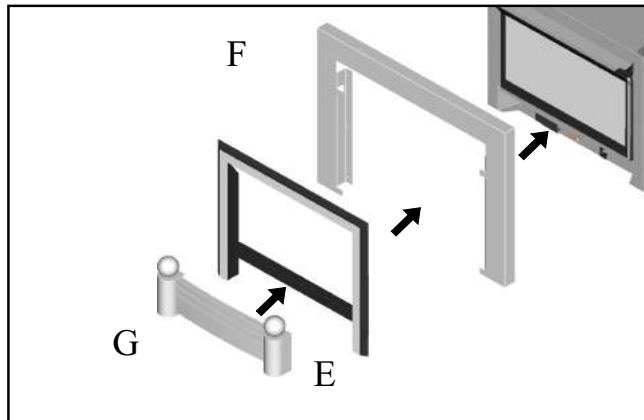
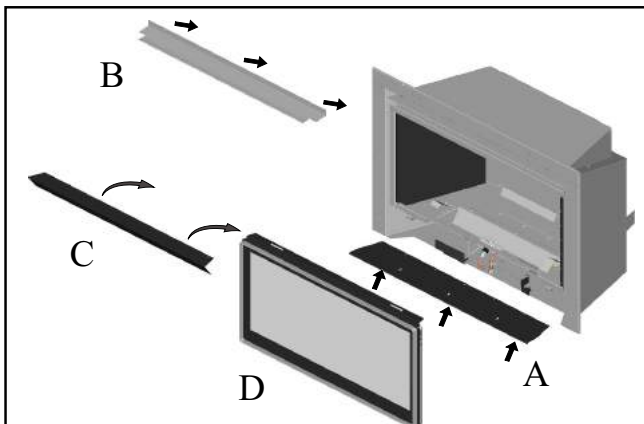

## OWNER GUIDE

This product uses fuel effect pieces, burner compartment walls and ceramic gravel containing Refractory Ceramic Fibres (RCF), which are man-made vitreous silicate fibres. Excessive exposure to this material may cause irritation to eyes, skin and respiratory tract. Consequently, it is important to take care when handling these articles to ensure that the release of dust is kept to a minimum.

– Light coatings of soot will usually be burnt off during the normal operation of the fire. Should any soot accumulation become excessive, the one piece overlay coal and ceramic fuel effect base should be removed from the fire for cleaning.

– Cleaning should be carried out in a well ventilated area or in the open air by gently brushing with the pieces held away from your face so that you avoid inhaling the dust.

– We do not recommend the use of a normal domestic vacuum cleaner which may blow dust back into the air.

– We suggest that you remove the ceramic fuel effect pieces in the reverse order to that shown in the ceramic fuel effect installer and owner guide.

– Once cleaned replace the fuel effect as in ceramic fuel effect installer and owner guide.

### **Burner.**

To gain access to the burner the window assembly and ceramic components must be removed as in the previous sections.

Remove any deposits of soot or other foreign matter from the surface of the burner with a dry soft brush. Be careful not to brush any particles into the open slots.

Remove any particles from the slots with a vacuum cleaner fitted with a soft brush attachment. **Do not poke wire, etc. into the slots in the burner.**

**Battery replacement.**

**Please note: In order to ensure maximum battery life and optimal performance, we recommend that only 'Long Life' alkaline type replacement batteries are used. The use of non-alkaline batteries will result in limited battery life'.**

**Handset.**

The remote control handset is battery powered. To replace the battery, remove the rear compartment cover from the remote control handset. To do this push the cover towards the bottom of the handset (See figure 11). Remove the existing battery. Fit a 9 Volt 'PP3' size battery in to the handset and replace the cover.

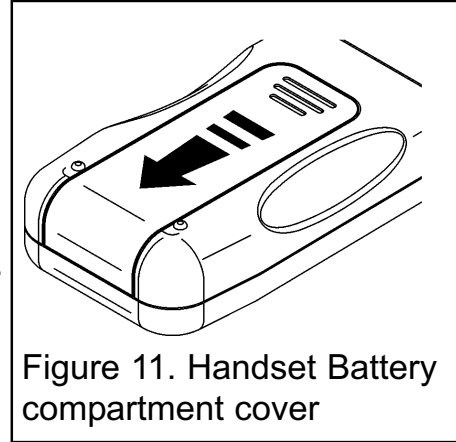

Figure 11. Handset Battery compartment cover

**Receiver box.**

The gas valve and receiver box are battery powered. To replace the batteries for both it will be necessary to remove the fascia. **Please read the SAFETY section at the start of the installer guide.**

– The fascia is made up of an inner trim and an outer fascia. The inner trim is secured with magnets and the fascia with thumbscrews. Hold the bottom of the inner trim and gently pull it forward, once released from the magnets lift the trim clear.

– The bottom of the fascia is held in place with thumbscrews. Unscrew and remove the thumbscrews from the perforated panel. Hold the lower outside edges of the fascia and gently pull forward. Lift the fascia upward and clear of the upper hanging brackets on the convection box.

– Gently pull the receiver box forward and clear of its support. Slide the battery compartment cover clear (See figure 12). Remove the existing batteries. Fit four 1.5 Volt 'AA' size batteries. It is important that the +ve and -ve symbols on the battery match those of the illustration inside the battery holder. Replace the cover, slide the receiver back into its support bracket and shut the access cover.

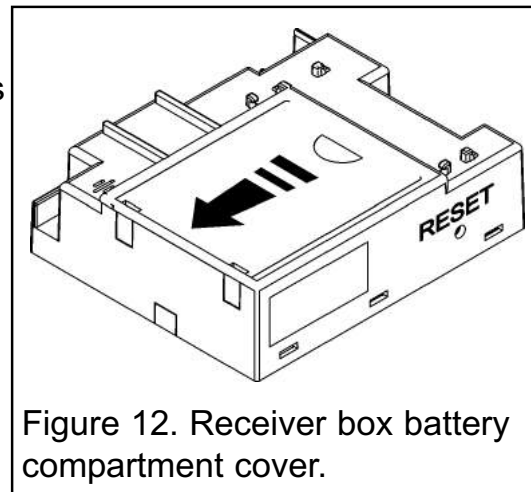

Figure 12. Receiver box battery compartment cover.

## **Regular maintenance.**

In order to achieve and maintain high levels of personal safety and performance efficiency, it is essential that the opening at the back of the fire and the flue are kept clear of any form of obstruction. It is possible that deposits of mortar or soot could fall and accumulate causing the flue to be blocked or restricted and so preventing proper clearance of dangerous exhaust fumes.

In the United Kingdom it is the law that a landlord must have any gas appliance, flue and pipework which is situated in a tenant's premises checked for safety at least every twelve months by a competent person (GAS SAFE REGISTER operative). We recommend that all gas appliances and their flues, wherever situated, are checked annually.

## **Replacement ceramics.**

If you wish to replace any of the ceramic fuel effect pieces, spare parts are available nationwide via the GDC Technical Helpline in the UK phone **0844 879 35 88** or in the Republic of Ireland phone **01 842 8222**.

### Standard Warranty Terms & Conditions

The warranty is for 12 months subject to contract.

In the United Kingdom servicing can be carried out either by a **GDC** service engineer or a **GAS SAFE REGISTER** engineer. Outside of the United Kingdom servicing can be carried out either by a **CORGI** or **GAS SAFE REGISTER** engineer.

You must register your fire in the UK by calling our telephone registration line on **0800 597 8500**.

It is also a requirement of the warranty that the fire has an annual service (every 12 months) in accordance with the installation and servicing instructions, performed by a **GAS SAFE REGISTER** engineer, (**CORGI** or **GAS SAFE REGISTER** outside of UK).

### Our promise to you

If you experience a fault with your new fire, we aim to provide a safe and high quality repair service supported by our dedicated national network of highly skilled engineers. If your installer can't resolve the problem for you, we will do everything we can to get an engineer out to you as quickly as possible. Nothing in this warranty will affect your statutory rights.

### What you need to do if you experience a problem with the operation of the fire:

- You should always contact your installer first, because the cause of the fault may not be related to the fire.
- If your installer confirms that the fault is with the fire and they can't repair it, our friendly customer service team is on hand to help.
- Simply call our GDC service division on **0844 879 35 88** to book an engineer visit or for any general advice that you may need. In the Republic of Ireland call **01 842 8222**.

When calling the **GDC Helpline**, it would be helpful if you could have the following information to hand:-

1. Fire serial number and fascia code (Located on the information label - See figure 13 on page 57)\*.
2. Date of installation\*
3. Your installer name and address details\*
4. Fire make and model number\*
5. Proof of purchase (if you do not have the fire serial number)

**Note: details 1 – 4 should be recorded on pages 57 & 58 at the end of this guide.**

## **What this warranty covers**

Free of charge repair or replacement of components found to be of faulty manufacture.

Free of charge replacement of the complete unit providing the failure is related to a manufacturing fault that cannot be repaired or is uneconomic to repair.

## **What this warranty does not cover**

Repairs to fires which haven't been installed and commissioned properly and as set out in the installation instructions.

Faults caused by inadequate supply of gas or electricity (where applicable).

Reimbursement of any third party repair or replacement costs that we haven't been told about or agreed with you in advance.

Compensation or consequential losses (e.g. loss of earnings, business losses, stress and inconvenience) arising from a production breakdown, including repair delays caused by factors outside our reasonable control.



# OWNER GUIDE

The following pages are to be completed by the installer:

Installer Details (Block Capitals)

Installer Name	
Gas Safe Register Number.	
Company Name.	
Company Address	
Company Telephone number	
Company Fax number	

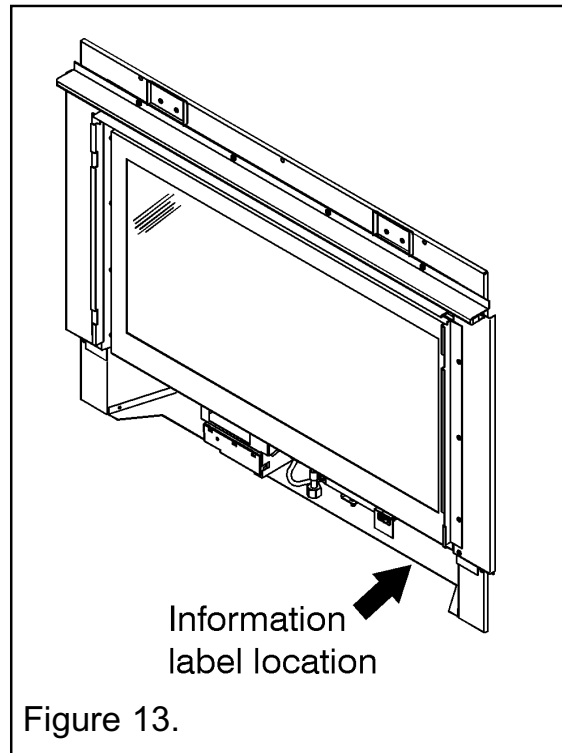

# OWNER GUIDE

Model

7 6 2

Serial number (A label containing this information may have been placed below or can be found on the serial number label - See figure 13)

□ □ □ □ □ □ □ □ □ □ □ □ □ □

A LABEL CONTAINING THE SERIAL NUMBER MAY HAVE BEEN PLACED INSIDE THIS BOX.

SERIAL NUMBER LABEL  
TO BE AFFIXED HERE

Fascia name (Block Capitals)

□ □ □ □ □ □ □ □ □ □

Fascia code - Can be found close to the information label (Block Capitals)

□ □ □ □ □ □ □ □ □ □ □ □ □ □

A LABEL CONTAINING THE FASCIA CODE MAY HAVE BEEN PLACED INSIDE THIS BOX.

FASCIA CODE LABEL  
TO BE AFFIXED HERE

Brand

□ Valor

Other.....

Date of Installation

□ □ □ □ □ □  
D D M M Y Y

GC Number

3 2 - 0 3 2 - 7 3



