

Smarty

Ⓝ	Brukerveiledning	2
Ⓞ	User manual	10
Ⓚ	Brugervejledning	15
Ⓢ	Installations- och bruksanvisning	21
Ⓕ	Käyttöohje	27



Product no: SN-00005-xxx
Sintef no: 110-0302
RRF no: 40 09 1921
Last updated: 01.01.2013

INDEX

1. Prior to assembling the stove	9
Chimney draught	9
Air supply	9
Dimensional drawing	10
2. Technical information	10
3. Distance to combustible material	10
4. Assembly	10
Base options	10
Operating control	11
Flue outlet collar	11
Connection of the flue	11
5. Lighting the fire for the first time	11
6. Maintenance	11
Cleaning and inspection	11
Ashes	11
Thermotte™ Plates	12
Door and glass	12
7. Warranty	12
8. Advice on lighting a fire	12
Some advice in case of combustion problems	14

1. Prior to assembling the stove

All our products are tested according to the latest European requirements and also to the **Norwegian standard NS 3058 and NS 3059**, which include particle tests. However, several European countries have local regulations for installation of fireplaces, which change regularly. It is the responsibility of the client that these regulations are complied with in the country/region where the fireplace is installed. Nordpeis AS is not responsible for incorrect installation.

Important to check

(please note that this list is not exhaustive):

- distance from firebox to combustible/flammable materials
- insulation materials/requirements between fireplace surround and back wall
- size of floor plates in front of fireplace if required
- flue connection between firebox and chimney
- insulation requirements if flue passes through a flammable wall

Chimney draught

Compared with older models, the clean burning stoves of today put significantly higher demands on the chimney. Even the best stove will not work properly if the chimney does not have the right dimensions or is not in good working order. The draught is mainly controlled by gas temperature, outside temperature, air supply as well as the height and inner diameter of the chimney. The diameter of the chimney should never be less than that of the flue/chimney collar. At nominal effect there should be a negative pressure of 12 to 25 Pascal.

The draught increases when:

- The chimney becomes warmer than the outside air
- The active length of the chimney over the hearth increases
- Good air supply to the combustion

It can be difficult to obtain the right draught conditions in case the chimney is too large relative to the stove, as the chimney does not heat up well enough. In such cases you may want to contact professional for evaluation of possible measures. Draught that is too strong can be controlled with a damper. If necessary, contact a chimney sweeper.

Air supply

A set for fresh air supply is available as accessory. This will ensure that the air supply to the combustion chamber is less affected by ventilation systems, kitchen fans and other factors which can create a down-draught in the room. In all new construction, we strongly recommend that it is designed and prepared for direct supply of outside air. In older houses, the use of fresh air supply set is also recommended. Insufficient air supply can cause down-draught and thereby low combustion efficiency and the problems that this entails: soot stains on the glass, inefficient use of the wood and a soot deposits in the chimney.

Dimensional drawing

The illustration indicates the approximate center height of the hole for the flue. Distortions in floors and walls may influence the height. Place the stove for accurate position and height of the flue/chimney connection.

We accept no liability for typographical errors and changes.

For your own safety, comply with the assembly instructions.

All safety distances are minimum distances. Installation of the insert must comply with the rules and regulations of the country where installed. Nordpeis AS is not responsible for wrongly assembled inserts.

2. Technical information

The stoves from Nordpeis all have secondary combustion and are clean burning. The combustion takes place in two phases: first the wood burns and then the gases from the fumes are lit by the hot air. This ensures that these new stoves have minimal emissions of soot particles and un-burnt gases (such as CO) and are thus better for the environment. Clean burning stoves require a small amount of wood in order to obtain a good heat output. Use exclusively clean and dry wood. We recommend seasoned hardwood with a maximum moisture content of 20%.

Material:	Cast iron
Surface treatment door/doorframe:	Heat resistant varnish
Fuel:	Wood logs, 30 cm
Operating range:	5 kW nominal
Efficiency:	81,2%
CO % @ 13% O₂:	0,07
Draught system:	Air vent control
Combustion system:	Secondary combustion (clean burning)
Heating area:	45-120 m ²
Flue outlet:	Top and rear
Flue:	Inner Ø 150 mm *Alternative versions exists due to National requirements
Weight of stove:	119 kg
Flue gas temperature	306 °C
Air supply requirements (m³/h):	11
Nominal load size	1,3kg
Loading interval	50min
Opening of the air vent control	100%

Operation	Intermittent*
------------------	---------------

* *Intermittent combustion refers to normal use of a fireplace, i.e. new wood is inserted when the previous load has burned down to ember.*

3. Distance to combustible material

Ensure that the safety distances are respected (FIG 1).

When connecting a steel chimney to the top outlet use the security distances required from the manufacturer.

4. Assembly

The following tools are necessary:

- 13 mm wrench (Classic and One)
- 10 mm wrench (Classic, Stone and One)
- 6 mm Allen key (Stone)
- 5 mm Allen key (Classic)
- 3 mm Allen key (Classic)

Base options

The stove is delivered with a pallet and cardboard which can be used as a protective base when laying the stove down for assembly. The Thermotte plates can be removed in order to make the stove lighter, (FIG 2). In case the Thermotte plates are not removed, the protective transportation insulation must stay in place, this to ensure that the plates do not fall down and break. **The stove must be lifted from vertical position. Do not tilt! It can damage the legs/base.**

Smarty Classic Legs

The Thermotte plates must be removed before assembling the legs

FIG 3: Remove the Allen screw

FIG 4: Assemble the legs with the screws that are included

FIG 5: Position the screws under each leg to level the stove

Smarty Stone Legs

FIG 6: Assemble the legs with the screws that are included

FIG 7: Use a wedge of appropriate material to level the stove

Smarty One Pedestal

FIG 8: Loosen the screws in the bottom of the pedestal in order to fit the column more easily

FIG 9: The pedestal is fastened at the top with four screws

FIG 10: Position the screws underneath in each corner to level the stove

FIG 11: The various heights for the flue outlet

FIG 12 A: Custom collar for assembly of 80 mm fresh air supply. Part of the Fresh Air Supply Kit

FIG 12 B: The lid is used when the fresh air supply is obtained from underneath the floor plate

FIG 13 C: The grid is placed when the fresh air supply set is not used

Operating control

When the stove is in position, check that all functions are easy to manoeuvre and appear satisfactory.

Door	
Handle turned downward	Closed
Handle turned upward	Opened

Air vent control (FIG 13)	
Pulled out	Open
Pushed it	Closed

Flue outlet collar

Smarty is delivered as standard with a posterior flue outlet collar. In order to change to a top mounted flue outlet:

FIG 14: Unscrew the top lid and the smoke baffle

FIG 15: Unscrew the posterior collar

FIG 16: Fasten the closing lid on the posterior outlet

FIG 17: Fasten the collar and the smoke baffle on the top outlet

Connection of the flue

Please be aware when connecting the 150 mm flue to the smoke dome that the flue is placed inside the flue outlet collar. *Alternative versions exist due to National requirements

For the flue connection to the chimney, follow the recommendations from the chimney manufacturer.

Fresh air supply

FIG 18-21: The possibility to connect a fresh air supply ducting set.

Removing the self-closing mechanism FIG 22

Open the door and gently loosen the small Allen screws with a 3mm Allen key

5. Lighting the fire for the first time

When the stove is assembled and all instructions have been observed, a fire can be lit.

Take care when inserting logs into the burn chamber, in order not to damage the Thermotte plates. Please note that there might be some humidity in the insulation plates which can result in a slower burn rate the first few times the stove is used. These will be resolved once the humidity has evaporated. Possibly leave the door slightly open the first 2-3 times that the stove is used. **It is advisable to ventilate the room well when firing for the first time as the varnish on the stove may release some smoke or smell.** Both the smoke and smell will disappear and are not hazardous.

Lighting a fire

Insert small dry pieces of kindling wood, ignite and ensure that the flames have established on the wood before closing the door. Open the air vent control (FIG 13) before you close the door. Additional ignition air is obtained by keeping the door slightly open. When the flames are stable and the chimney is warm, the air supply is regulated with the air vent control.

When there is a glowing layer of ash, new wood logs can be inserted. Pull the hot ember to the front of the combustion chamber when inserting new logs so that the wood is ignited from the front. Keep the door slightly open each time new logs are inserted so that the flames get established. The fire should burn with bright and lively flames.

Using the stove with low combustion effect and firing around the clock increase pollution as well as the risk for a fire in the chimney. Never allow the stove or flue to become glowing red. Turn off the air vent control should this happen. Regulation of the air vent control takes some experience, but after a little while a natural rhythm for the fire will be found.

IMPORTANT! Always remember to open the air vent control and the door when new wood logs are inserted into a hot burn chamber. Let the flames get established on the wood before the air supply is reduced.

When the draught in the chimney is low and the vents are closed, the gas from the firewood can be ignited with a bang. This can cause damages to the product as well as the immediate environment.

6. Maintenance

Cleaning and inspection

The stove should be inspected thoroughly and cleaned at least once per season (possibly in combination with the sweeping of the chimney and chimney pipes). Ensure that all joints are tight and that the gaskets are rightly positioned. Exchange any gaskets that are worn or deformed.

Remember that the stove must always be cold when inspected.

Ashes

The ashes should be removed at regular intervals. Be aware that the ashes can contain hot ember even several days after the fire is finished. Use a container of non-combustible material to remove the ashes. It is recommended to leave a layer of ashes in the bottom as this further insulates the burn chamber. Take care with the Thermotte plates when the ashes are removed, particularly when using an ash shovel, so as not to damage them.

Thermotte™

The insulating plates in the burn chamber (FIG 2) contribute to a high combustion temperature, which leads to cleaner combustion of the wood and a higher rate of efficiency. Any fissures in the plates will not reduce their insulation efficiency.

If new plates are needed, contact your dealer. *Please* In case the Thermotte plates need to be replaced, lift the smoke baffle (A) in order to remove the sideplates.

- A. Smoke baffle
- B. Right side plate
- C. Left side plate
- D. Ash grate
- E. Ash tray
- F. Bottom plate, two parts

note: Wood logs that are too long can cause strain and crack the plates, due to the tension created between the side plates.

Please note that the Thermotte plates may release coloured dust when touched. Avoid touching any cast iron parts with dust on your fingers. Any visible dust on cast iron can be brushed off with the glove that is included.

Door and glass

Should there be any soot on the glass it may be necessary to clean it. Use dedicated glass cleaner, as other detergents may damage the glass. (NB! Be careful, even dedicated glass cleaner can damage the varnish on the door frame). A good advice for cleaning the glass is to use a damp cloth or kitchen roll paper and apply some ash from the burn chamber. Rub the ash on the glass and finish off with a piece of clean and damp kitchen roll paper. NB! Only clean when the glass is cold.

Check regularly that the transition between the glass and the door is completely tight. Possibly tighten the screws that hold the glass in place - but not too hard, as this can cause the glass to crack.

Periodically, it may be necessary to change the gaskets on the door to ensure that the burn chamber is air tight and working optimally. These gaskets can be bought as a set, usually including ceramic glue.

**CERAMIC GLASS
CANNOT BE
RECYCLED**

**Ceramic glass should
be disposed of as residual
waste, together with
pottery and porcelain**



Recycling of the ceramic glass

Ceramic glass cannot be recycled. Old glass, breakage or otherwise unusable ceramic glass, must be discarded as residual waste. Ceramic glass has a higher melting temperature, and can therefore not be recycled together with glass. In case it would be mixed with ordinary glass, it would damage the raw material and could, in worst case end the recycling of glass. It is an important contribution to the environment to ensure that ceramic glass does not end up with the recycling of ordinary glass.

Packaging recycle

The packaging accompanying the product should be recycled according to national regulations.

7. Warranty

For detailed description of the warranty conditions see the enclosed warranty card or visit our website www.nordpeis.com

8. Advice on lighting a fire

The best way to light a fire is with the use of lightening briquettes and dry kindling wood. Newspapers cause a lot of ash and the ink is damaging for the environment. Advertising flyers, magazines, milk cartons and similar are not suitable for lighting a fire. Good air supply is important at ignition. When the flue is hot the draught increases and door can be closed.

Warning: NEVER use a lighting fuel such as petrol, kerosene, alcohol or similar for lighting a fire. This could cause injury to you as well as damaging the product.

Use clean and dry wood with a maximum moisture content of 20%. The wood should be dried for a minimum of 6 months after it is cut. Humid wood requires a lot of air for the combustion, as extra energy/heat is required for drying the humid wood and the heat effect is therefore minimal. This in addition creates soot in the chimney with the risk of creosote and chimney fire.

Storing of wood

In order to ensure that the wood is dry, the tree should be cut in winter and stored during the summer, covered and in a location with adequate ventilation. The wood pile must never be covered by a tarpaulin lying against the ground as the tarpaulin will then act as a sealed lid that will prevent the wood from drying. Always keep a small amount of wood indoors for a few days before use so that moisture in the surface of the wood can evaporate.

Usage

Not enough air to the combustion may cause the glass to soot. Hence, supply the fire with air just after the wood is added, so that the flames and gases in the combustion chamber are properly burnt. Open the air vent and have the door slightly ajar in order for the flames to establish properly on the wood.

Note that the air supply for the combustion also can be too large and cause an uncontrollable fire that very quickly heats up the whole combustion chamber to an extremely high temperature (when using with a closed or nearly closed door). For this reason you should never fill the combustion chamber completely with wood.

It is recommended to keep an even fire with a small amount of wood. Too many logs put on hot ember, may result in combustion air starvation, and the gases will be released unburnt. For this reason it is important to increase the air supply just after adding logs.

Choice of fuel

All types of wood, such as birch, beech, oak, elm, ash and fruit trees, can be used as fuel in the insert. Wood species have different degrees of density - the more dense the wood is, the higher the energy value. Beech, oak and birch has the highest density.

Attention! We do not recommend using fuel briquettes/ compact wood in our products. Use of such fuel may cause the product to overheat and exceed the temperatures determined safe. Burning briquettes/ compact wood is done so at your own risk and only small amounts (max 1/3 of normal load) should be used for each load.

Warning:

NEVER use impregnated wood, painted wood, plywood, chipboard, rubbish, milk cartons, printed material or similar. If any of these items are used as fuel the warranty is invalid.

Common to these materials is that during combustion they can form hydrochloric acid and heavy metals that are harmful to the environment, yourself and the insert. Hydrochloric acid can also corrode the steel in the chimney or masonry in a masonry chimney. Also, avoid burning with bark, sawdust or other extremely fine wood, apart from when lighting a fire. This form of fuel can easily cause a flashover that can lead to temperatures that are too high.

Warning:

Make sure the insert is not overheated - it can cause irreparable damage to the product. Such damage is not covered by the warranty.

Source "Håndbok, effektiv og miljøvennlig vedfyring" by Edvard Karlsvik SINTEF Energy Research AS and Heikki Oravainen, VTT.
<http://www.eufirewood.info>

Some advice in case of combustion problems

Error	Explanation	Solution
No draught	The chimney is blocked	Contact a chimney sweeper / dealer for more information or clean the flue, smoke baffle and burn chamber.
	The flue is sooty or there is accumulated soot on the smoke baffle	
	The smoke baffle is wrongly positioned	Verify the assembly of the smoke baffle - see assembly instructions.
The stove release smoke when lighting the fire and during combustion	Downdraught in the room caused by no draught, that the house is too "air tight".	Light the fire with an open window. If this helps, more/bigger vents must be installed in the room.
	Downdraught in the room – caused by extractor and/or central ventilation system that pulls too much air out of the room.	Turn off/regulate extractor and/or other ventilation. If this helps, more vents must be installed.
	The flues from two fireplaces/stoves are connected to the same chimney at the same height.	One flue must be repositioned. The height difference of the two flue pipes must be of at least 30 cm.
	The flue is in a declining position from the smoke dome to the chimney.	The flue must be moved so that there is an inclination of at least 10° from smoke dome to chimney. Possibly install a smoke suction device*.
	The flue is too far into the chimney.	The flue must be reconnected so that it does not enter into the chimney but ends 5 mm before the chimney inner wall. Possibly install a smoke suction device*.
	Soot hatch in the basement or attic that is open and thus creating a false draught.	Soot hatches must always be closed. Hatches that are not tight or are defected must be changed.
	Damper/top draught vents or doors on fireplaces that are not in use are open and create a false draught.	Close damper, doors and top draught vents on fireplaces that are not in use.
	An open hole in the chimney after that a fireplace has been removed, thus creating a false draught.	Holes must be completely sealed off with masonry.
	Defect masonry in the chimney, e.g. it is not airtight around the flue pipe entry and/or broken partition inside the chimney creating a false draught.	Seal and plaster all cracks and sites that are not tight.
	The cross-section in the chimney is too large which results in no or very low draught.	The chimney must be refitted, possibly install a smoke suction device*.
	The cross-section in the chimney is too small and the chimney cannot carry out all the smoke.	Change to a smaller fireplace or build new chimney with a larger cross section. Possibly install a smoke suction device*.
The chimney is too low and hence a poor draught.	Increase the height of the chimney and/or install a chimney cap/ smoke suction device*.	
The stove releases smoke inside when it is windy outside.	The chimney is too low in relationship to the surrounding terrain, buildings, trees etc.	Increase the height of the chimney and/or install a chimney cap/ smoke suction device*.
	Turbulence around the chimney due to the roof being too flat.	Increase the height of the chimney and/or install a chimney cap/ smoke suction device*.
The stove does not heat sufficiently.	The combustion receives too much oxygen due to a leakage under the lower border of the stove or too strong chimney draught. Difficult to regulate the combustion and the wood burn up too quickly.	Any possible leakage must be sealed off. A draught regulator or possibly a damper can reduce the chimney draught. NB! A leakage of only 5 cm ² is enough for 30% of the heated air to disappear.
Too much draught	The smoke buffer is wrongly positioned.	Verify the positioning of the smoke buffer – see assembly instructions.
	In case of using oven-dried wood, this requires less air supply than when using normal wood.	Turn down the air supply.
	The gaskets around the door are worn and totally flat.	Replace the gaskets, contact your dealer.
	The chimney is too large.	Contact chimneysweeper or other professional for more details.
The glass is sooty	The wood is too wet.	Only use dry wood with a humidity of maximum 20%.
	The air vent control is closed too tightly.	Open the air vent control to add air to the combustion. When new wood logs are inserted all vent controls should be completely opened or the door slightly opened until the flames have a good take on the wood.
White glass	Bad combustion (the temperature is too low)	Follow the guidelines in this user guide for correct combustion.
	Using wrong material for combustion (such as: painted or impregnated wood, plastic laminate, plywood etc)	Ensure to use only dry and clean wood.
Smoke is released when the door is opened	A levelling out of pressure occurs in the burn chamber.	Open the air vent control for about 1 min before opening the door – avoid opening the door too quickly.
	The door is opened when there is a fire in the burn chamber.	Open the door carefully and/or only when there is hot ember.
White smoke	The combustion temperature is too low.	Increase the air supply.
	The wood is humid and contains water damp.	Ensure to use only dry and clean wood.
Black or grey/black smoke	Insufficient combustion.	Increase the air supply.

*Electric top chimney fan

Smarty Classic = mm

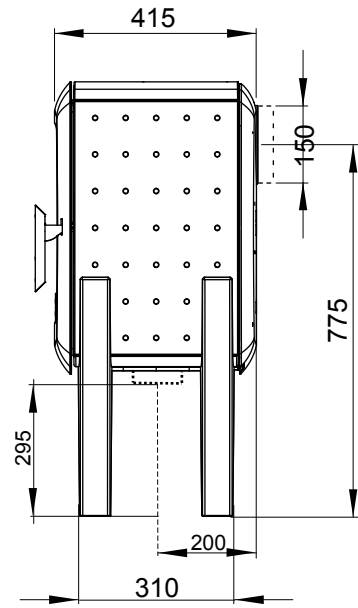
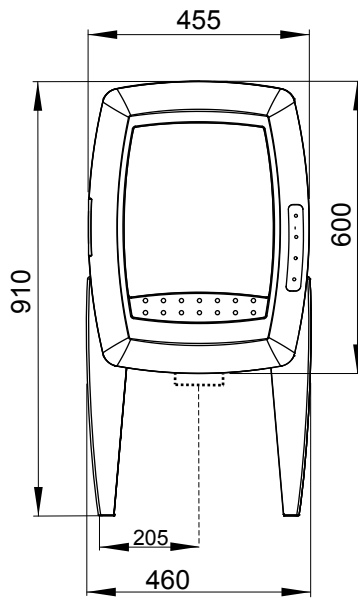
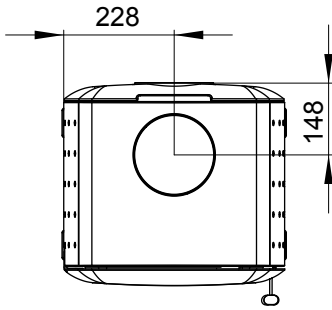

Smarty Stone = mm

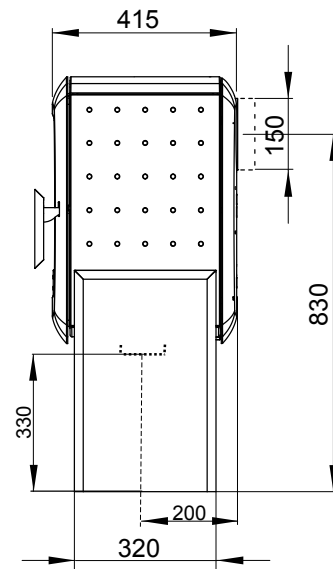
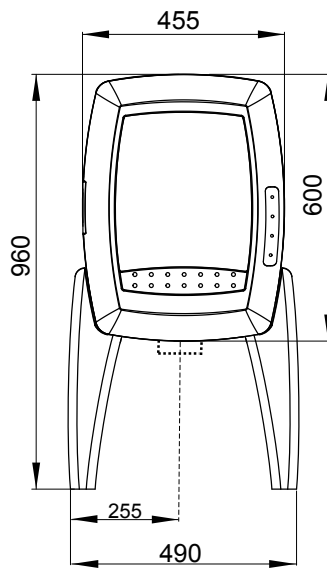
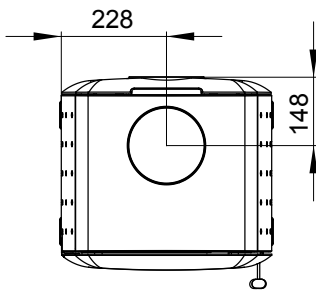

Smarty One leg = mm

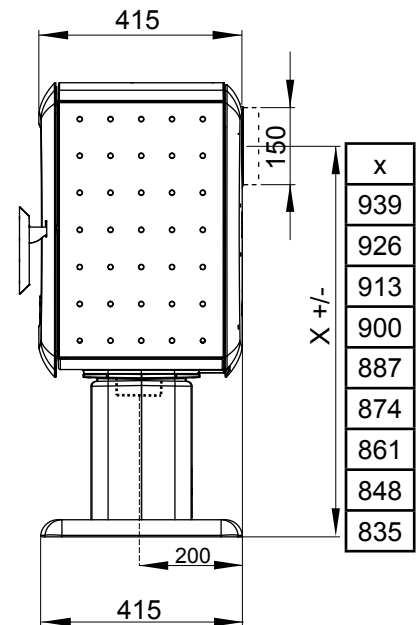
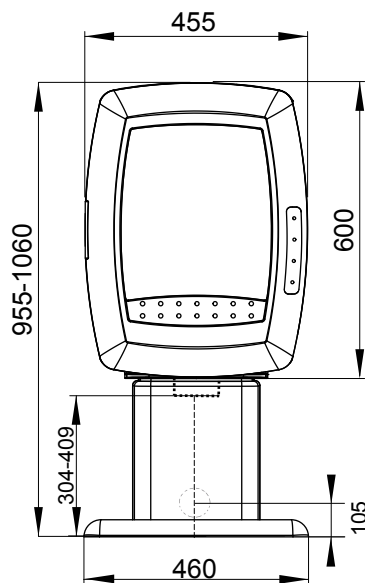
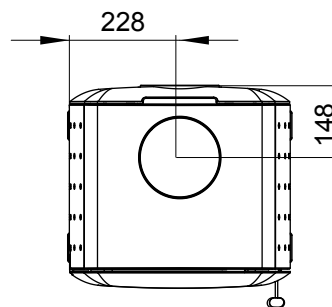



FIG 1

 =Brannmur/Brandmur/Turvaetäisyydet/Firewall

 =Brennbart materiale/Brændbart materiale/ Brännbart material/ Palavasta materiaalista/Combustible material

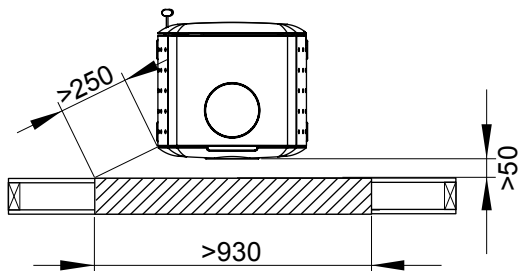
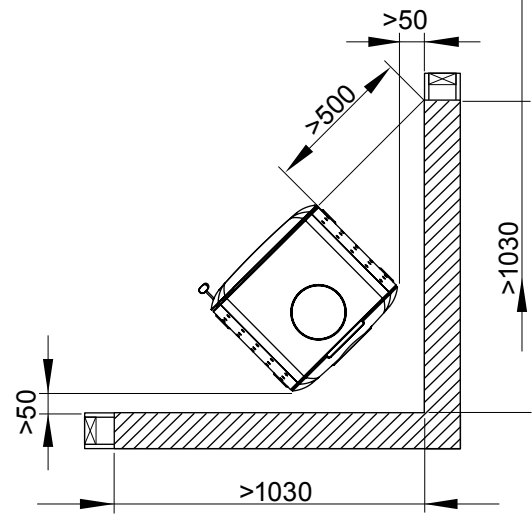
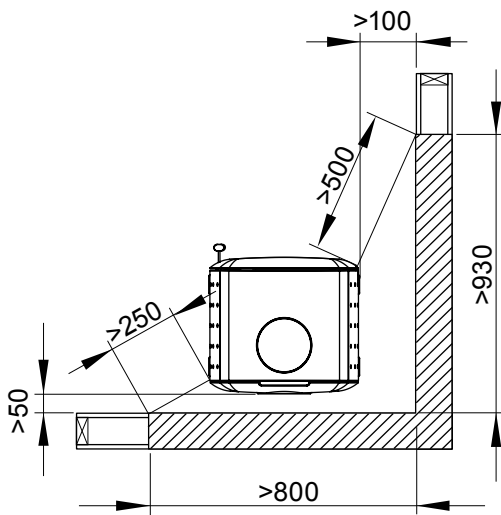
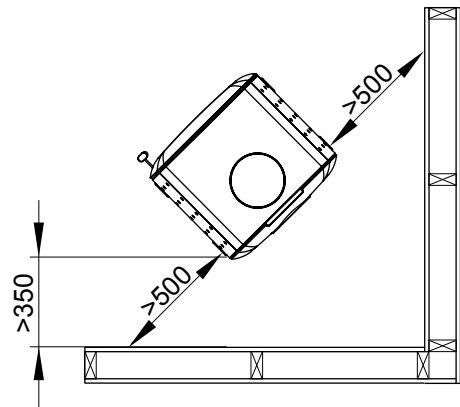
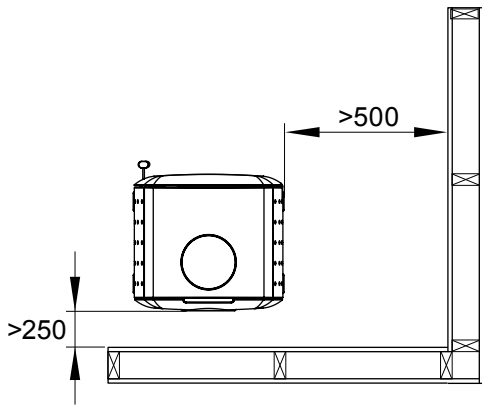

FIG 2

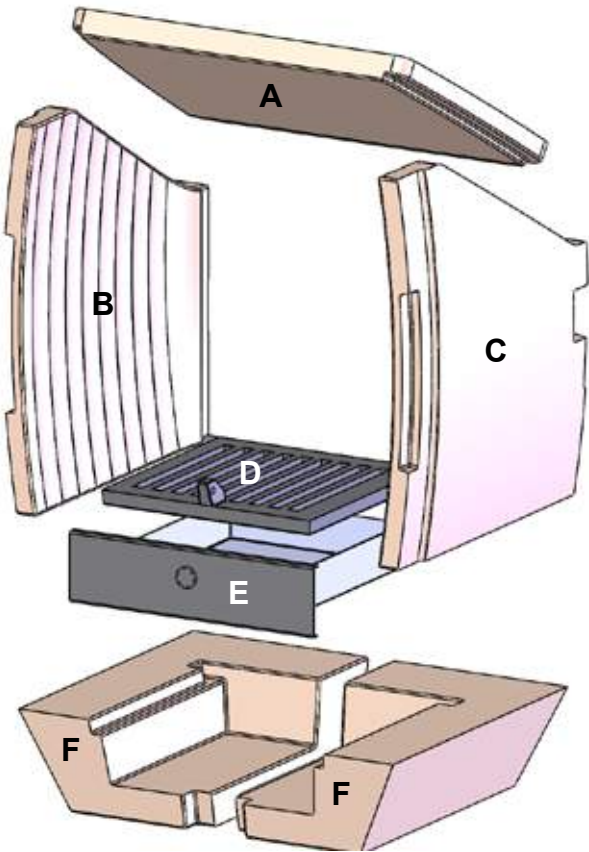

FIG 3 Classic



FIG 4 Classic

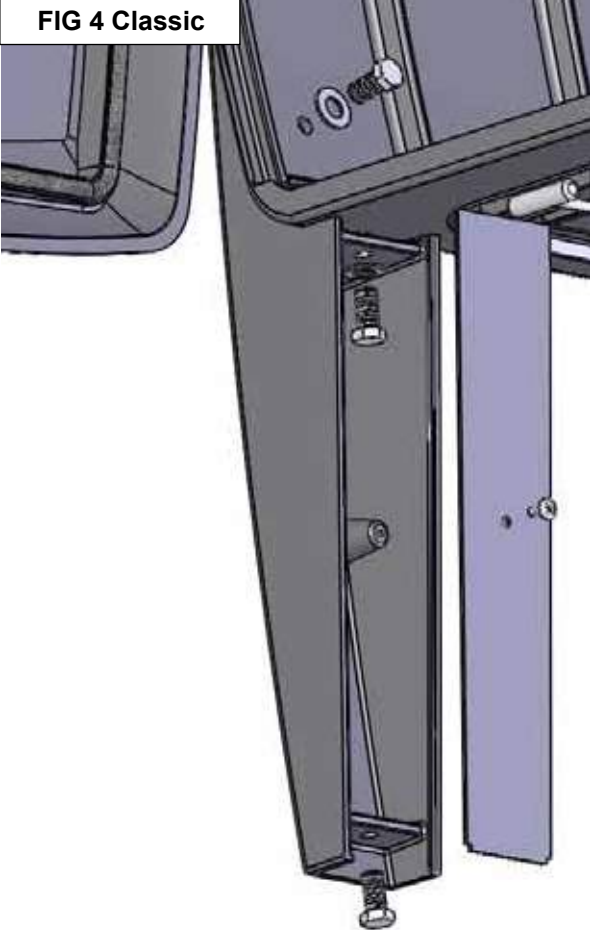

FIG 5 Classic

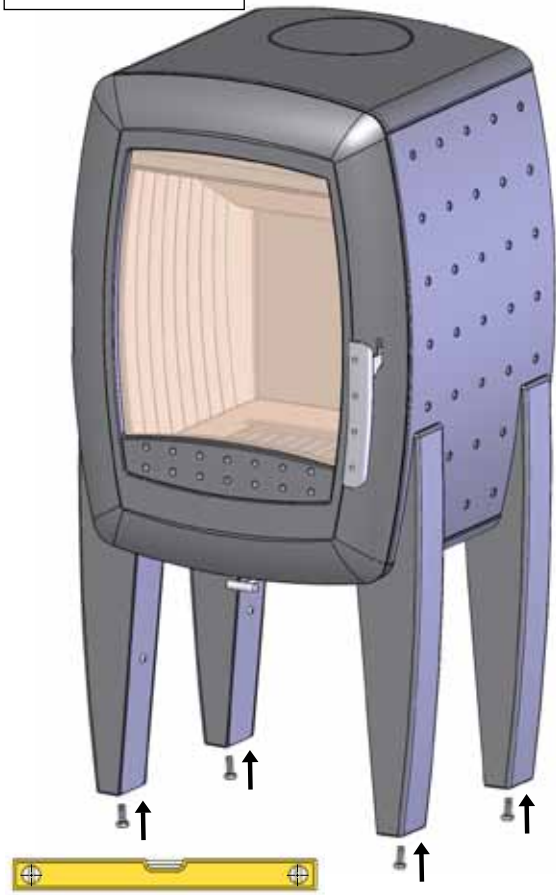

FIG 6 Stone

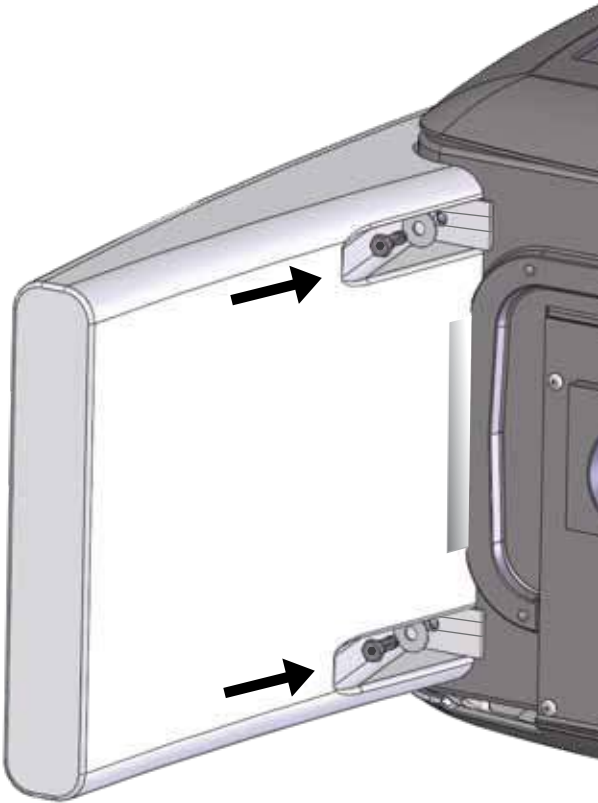

FIG 7 Stone

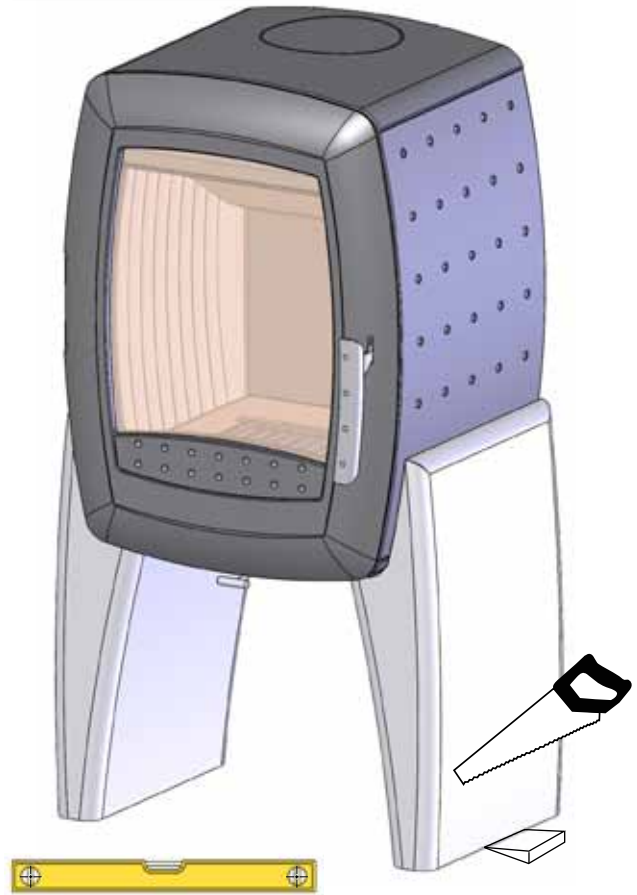

FIG 8 One leg

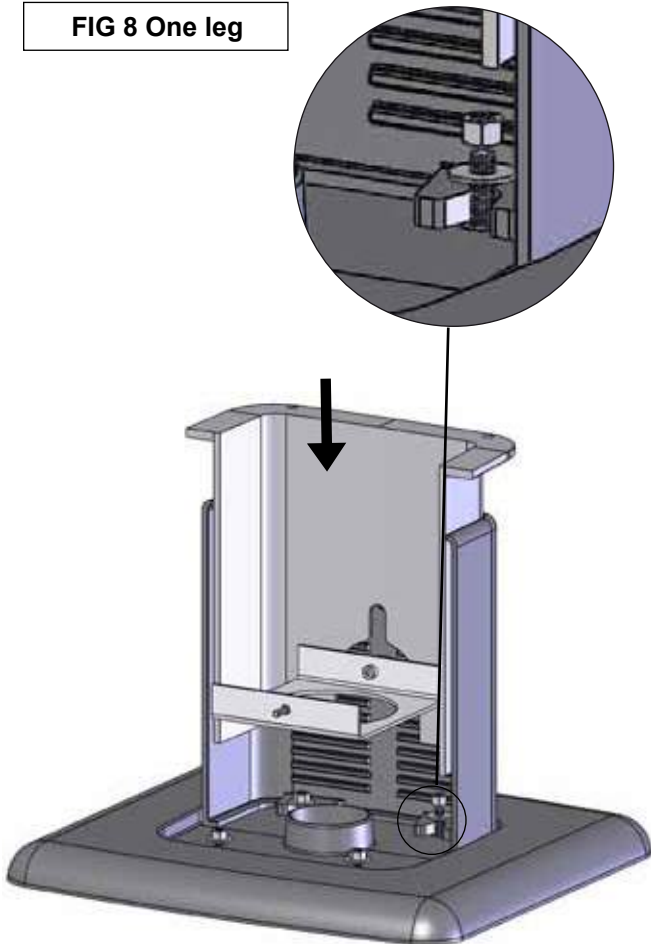

FIG 9 One leg

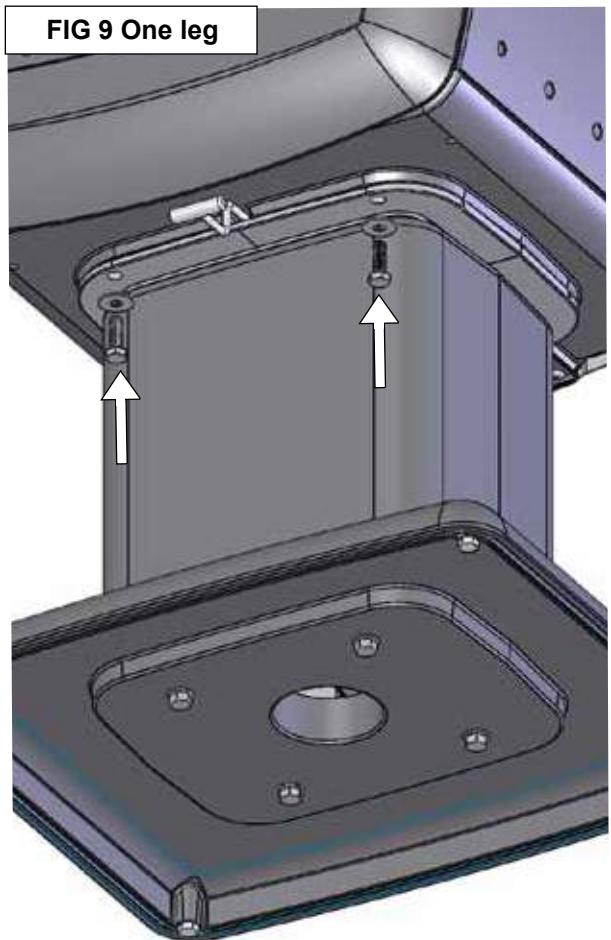

FIG 10 One leg

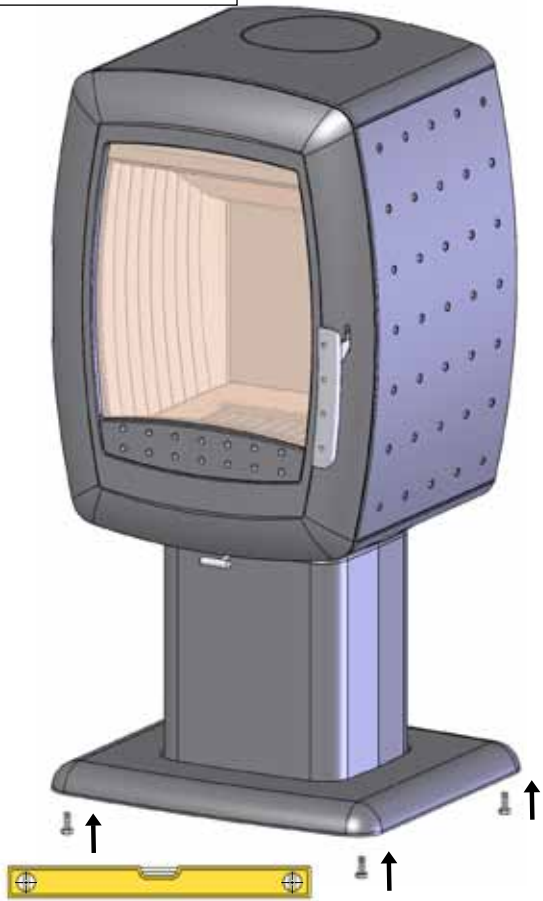

FIG 11 One leg

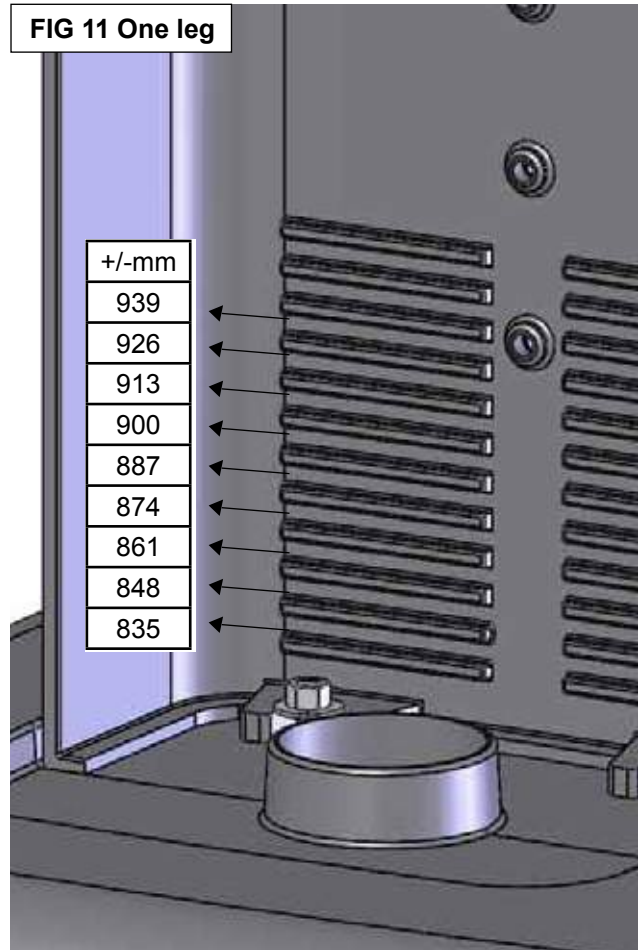

FIG 12 One leg



FIG 13

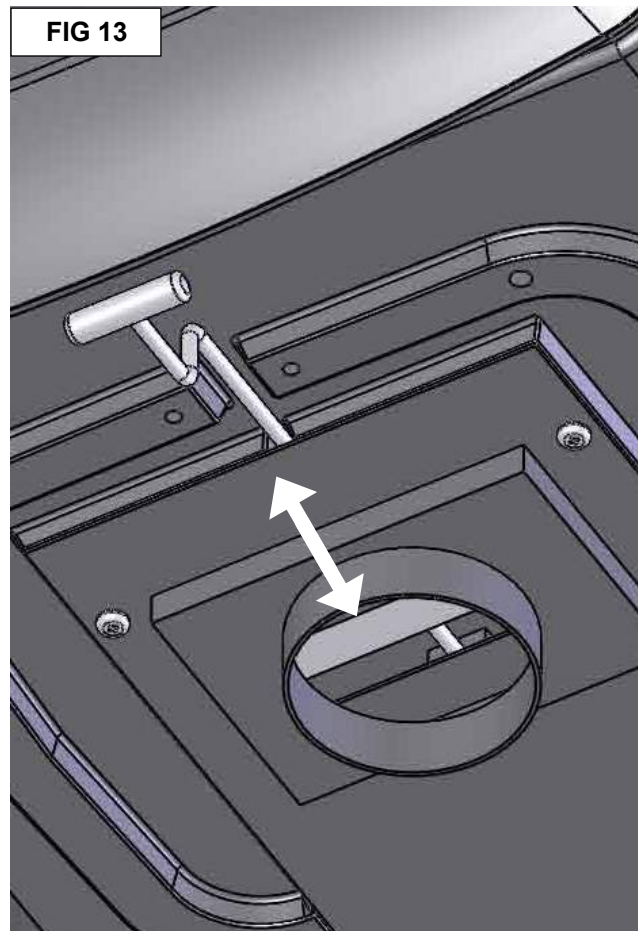

FIG 14

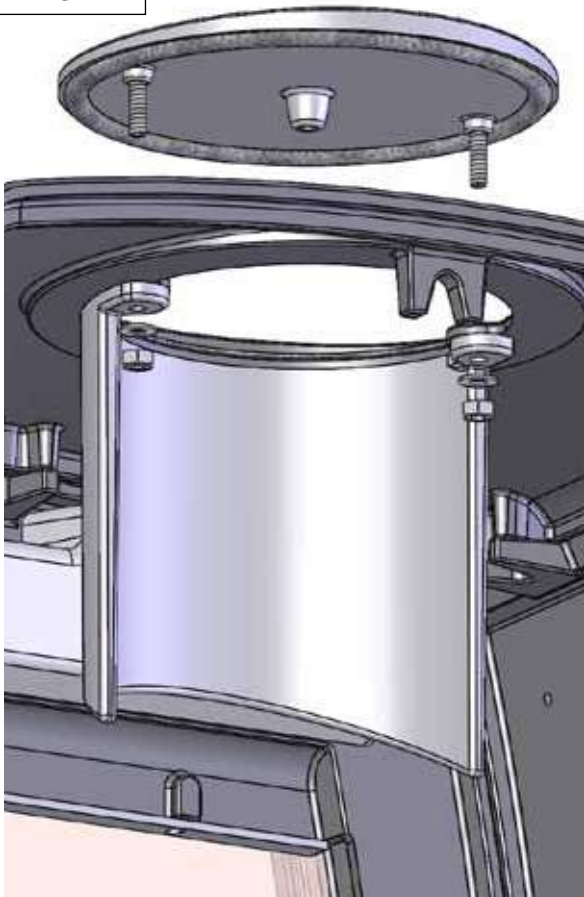

FIG 15



FIG 16

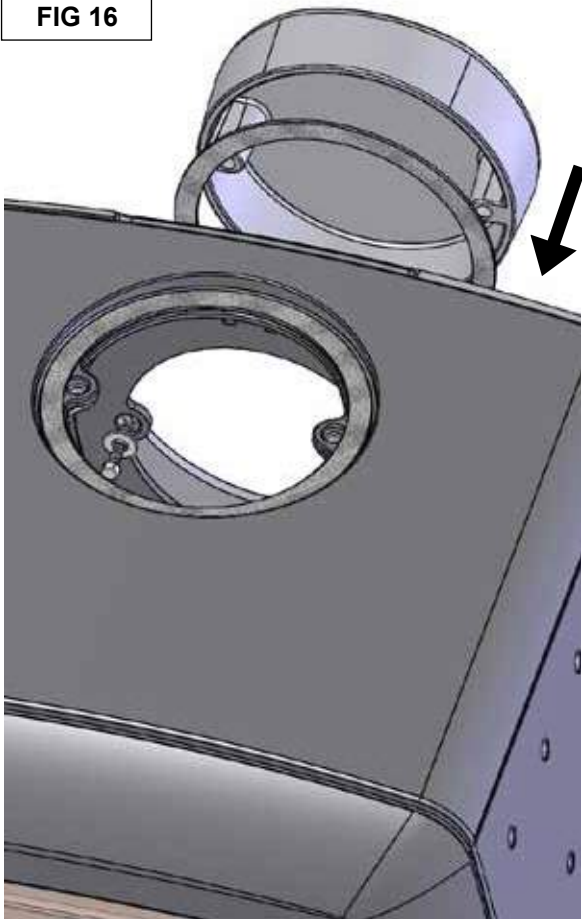

FIG 17

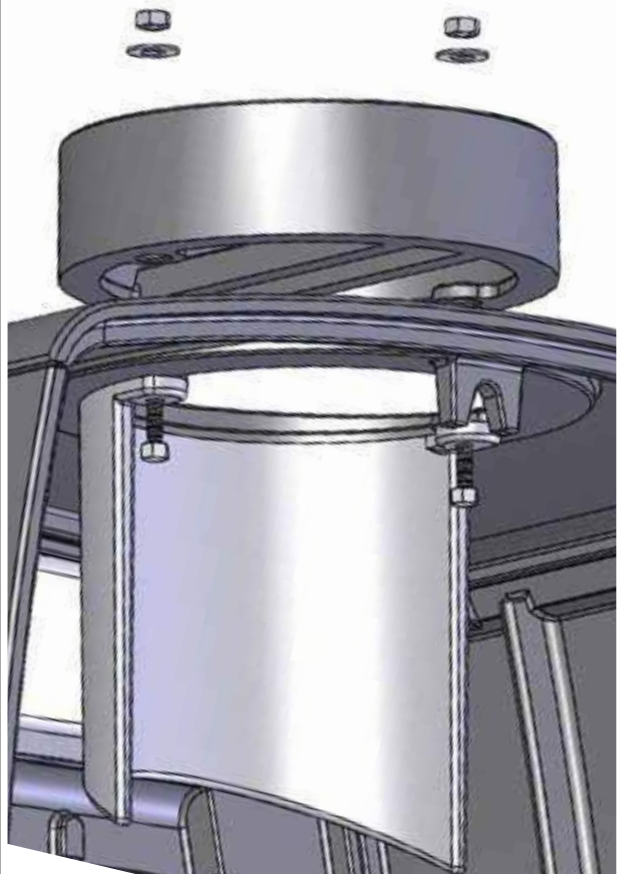

FIG 18

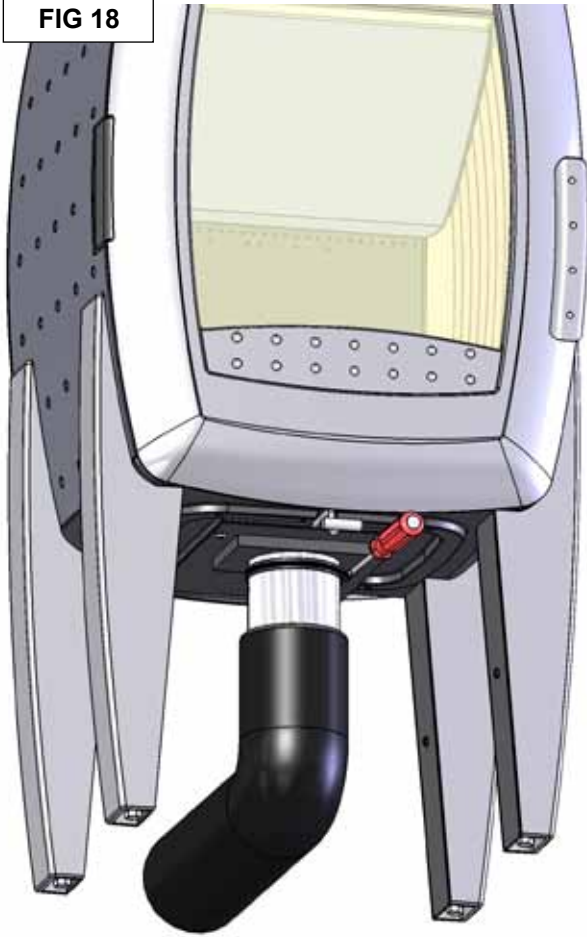

FIG 19

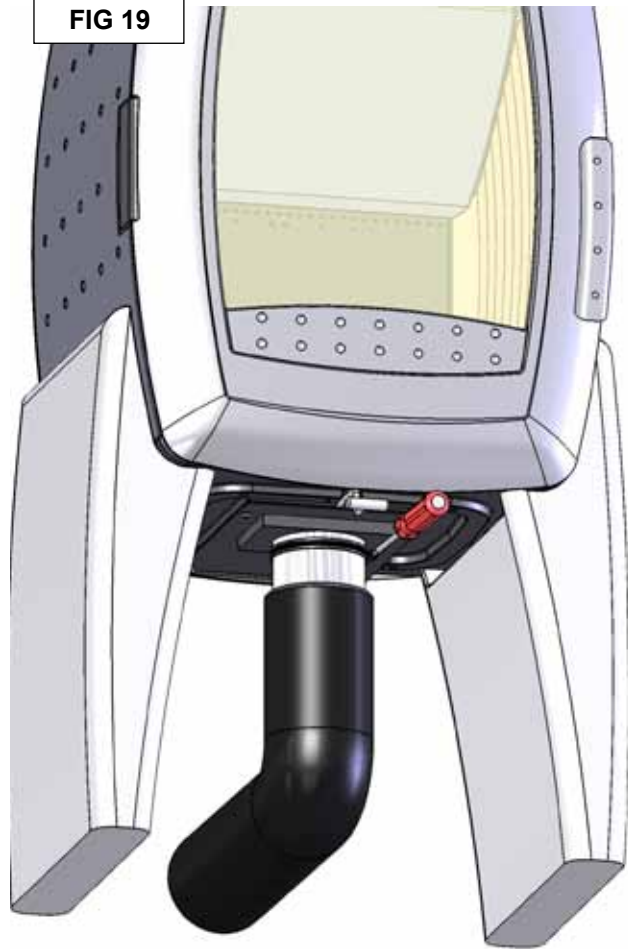

FIG 20



FIG 21

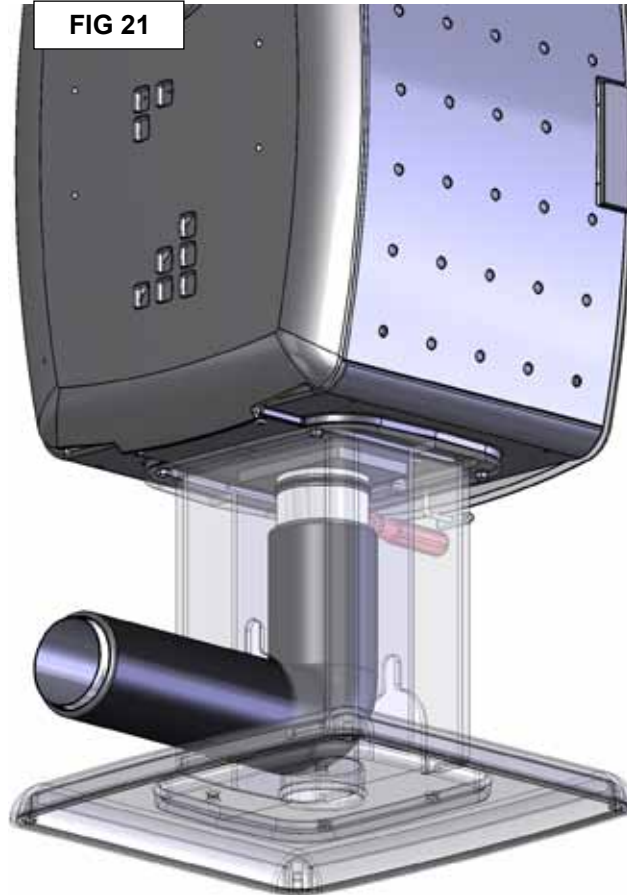
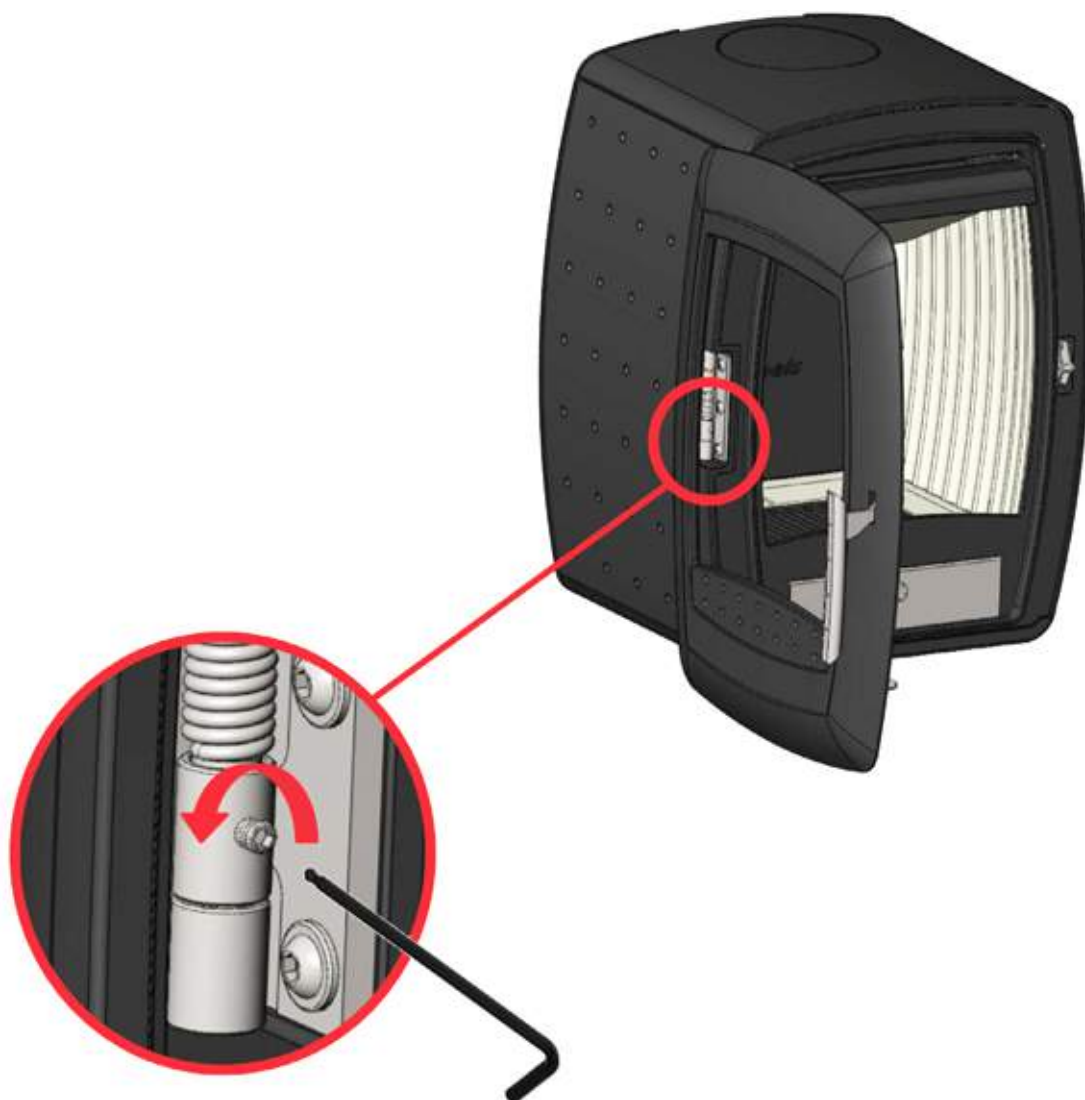

FIG 22



 **Nordpeis**

Nordpeis AS, Gjellebekkstubben 11, N-3420 LIERSKOGEN, Norway
www.nordpeis.no