



# Mendip Stoves

Woodburning & Multi Fuels

## OPERATION AND INSTALLATION MANUAL

Multi-fuel

Burcott

Fireplace inset stove





# Installation Manual and Operating instructions

## **BURCOTT fireplace inset stove**

This manual refers to the stoves listed above, which are tested in accordance with EN 13240.

Congratulations on your purchase of a new stove from Mendip Stoves. Please read this manual carefully to ensure that you get maximum enjoyment from your new stove and to prevent any problems. Please note that “all local regulations, including those referring to national and European Standards, need to be complied with when installing this appliance”.

For further information on installing and using fireplaces and wood burning stoves, please see the relevant building regulations that apply to the country in which Burcott fireplace inset stove has been approved, as well as the relevant information on the correct use of stoves available from your local stove supplier or your registered installation engineer.

These instructions cover the basic principals to ensure the satisfactory installation for Burcott multi-fuel Fireplace inset stove, although detail may need slight modification to suit particular local site conditions.

	Height	Width	Depth	Total depth	Weight
<b>External dimensions</b>					
<b>Burcott</b>	510	390	110		
<b>Building in dimensions</b>					
<b>Burcott</b>	420	285	170		80g





## HEALTH AND SAFETY PRECAUTIONS

### INFORMATION FOR THE USER, INSTALLER AND SERVICE ENGINEER

Special care must be taken when installing the stove such that the requirements of the Health and Safety at Work Act are met.

#### Handling

Adequate facilities must be available for loading, unloading and site handling.

#### Fire Cement

Some types of fire cement are caustic and should not be allowed to come into contact with the skin. In case of contact wash immediately with plenty of water.

## PREPARATORY WORK AND SAFETY CHECKS

### IMPORTANT WARNING

This stove must not be installed into a chimney that serves any other heating appliance. There must not be an extractor fan fitted in the same room as the stove because this can cause the stove to emit fumes into the room.

#### Asbestos

This stove contains no asbestos. If there is a possibility of disturbing any asbestos in the course of installation then please seek specialist guidance and use appropriate protective equipment.

#### Metal Parts

When installing or servicing this stove care should be taken to avoid the possibility of personal injury.

#### CO Alarms:-

Building regulations require that when ever a new or replacement fixed solid fuel or wood/biomass appliance is installed in a dwelling a carbon monoxide alarm must be fitted in the same room as the appliance. Further guidance on the installation of the carbon monoxide alarm is available in BS EN 50292:2002 and from the alarm manufacturer's instructions. **Provision of an alarm must not be considered a substitute for either installing the appliance correctly or ensuring regular servicing and maintenance of the appliance and chimney system.**

#### Stove paint Aerosols

Paint aerosols are flammable and therefore dangerous to use around a lit stove. Be sure to allow aerosols spray paints to dry and ventilate the room well before lighting the stove. The use of any aerosol around lit stove is dangerous and care must be take in handling aerosols.

These instructions cover the basic principles to ensure the satisfactory installation of the Mendip Stoves Ltd :-

Burcott fireplace inset stove , although detail may need slight modification to suit particular local site conditions.

In all cases the installation must comply with current Building Regulations, Local Authority Byelaws and other specifications or regulations as they affect the installation of the stove.

It should be noted that the Building Regulations requirements may be met by adopting the relevant recommendations given in British Standards BS 8303, BS EN 15287 as an alternative means to achieve an equivalent level of performance to that obtained following the guidance given in Approved Document J.





# STOVE PERFORMANCE & TESTING

MENDIP STOVES BURCOTT Fireplace inset stove is approved and tested in accordance with EN 13240.

	Output wood fuel	Efficiency	CO@13% o2	Recommended for smoke control Oct 2012	Output coal fuel	Efficiency	CO@13% o2
<b>Burcott</b>	4.1kw	83%	0.38	no	3.9kw	79%	0.36

**Stove model Weight & Nominal heat output for Wood and Smokeless fuels**

	Log length	Wood reload	Weight wood load	Coal reload	Weight coal (anth)
<b>Burcott</b>	20cm	1hr	875 g	2hr	900g

## Chimney Connection

In order for the stove to perform satisfactorily the chimney height must be sufficient to ensure an adequate draught to clear the products of combustion and prevent smoke problems into the room.

Tested Gas flow rates flue gas temperatures	Flue gas flow rate Wood /coal	Test flue gas temperature wood /coal	@ pascals of pressure
<b>Burcott</b>	2.8/4.0g/sec	217/184 deg C	12 pa

NOTE: A chimney height of not less than 4.5 metres measured vertically from the outlet of the stove to the top of the chimney should be satisfactory. Alternately the calculation procedure given in BS 5854:1980 may be used as the basis for deciding whether a particular chimney design will provide sufficient draught.





## Flue and Chimney connection to your stove

The outlet from the chimney should be above the roof of the building in accordance with the provisions of Building Regulations Approved Document J.

If installation is into an existing chimney then it must be sound and have no cracks or other faults which might allow fumes into the house. Older properties, especially, may have chimney faults or the cross section may be too large i.e., more than 200 mm x 200 mm. Remedial action should be taken, if required, seeking expert advice. If it is found necessary to line the chimney then a flue liner suitable for solid fuel must be used in accordance with Building Regulations Approved Document J.

Any existing chimney must be clear of obstruction and have been swept clean immediately before installation of the stove. If the stove is fitted in place of an open fire then the chimney should be swept one month after installation to clear any soot falls which may have occurred due to the difference in combustion between the stove and the open fire.

If there is no existing chimney then either a prefabricated block chimney in accordance with Building Regulations Approved Document J or a twin walled insulated stainless steel flue to BS 1856-1 can be used. These chimneys must be fitted in accordance with the manufacturer's instructions and Building Regulations.

A single wall metal flue pipe is suitable for connecting the stove to the chimney but is not suitable for using for the complete chimney. The chimney and connecting flue pipe must have a minimum diameter of 150 mm and its dimension should be not less than the size of the outlet socket of the stove. Any bend in the chimney or connecting flue pipe should not exceed 45°. 90° bends should not be used other than within 150 mm of stove rear flue outlet.





### Flue and Chimney connection to your stove (continued)

If it is found that there is excessive draught in the chimney then either an adjustable flue damper or alternately a draught stabiliser should be fitted. The adjustable flue damper should not close off the flue entirely but should in its closed position leave a minimum continuous opening free area of at least 20 % of the total cross sectional area of the flue or flue pipe.

Adequate provision e.g. easily accessible soot door or doors must be provided for sweeping the chimney and connecting flue pipe

Your appliance needs to be maintained routinely, the throat plate/baffle should be cleaned regularly (monthly) . The flue pipe can be cleaned using a flexible brush. Only Use a damp cloth on external surfaces. Over time the glass may become dirty, clean with a damp cloth and polish off with damp cloth. If the stove has not been used for some time the flue should be checked for blockages before use.

Do not modify the appliance; only use spares authorised by the manufacturer.

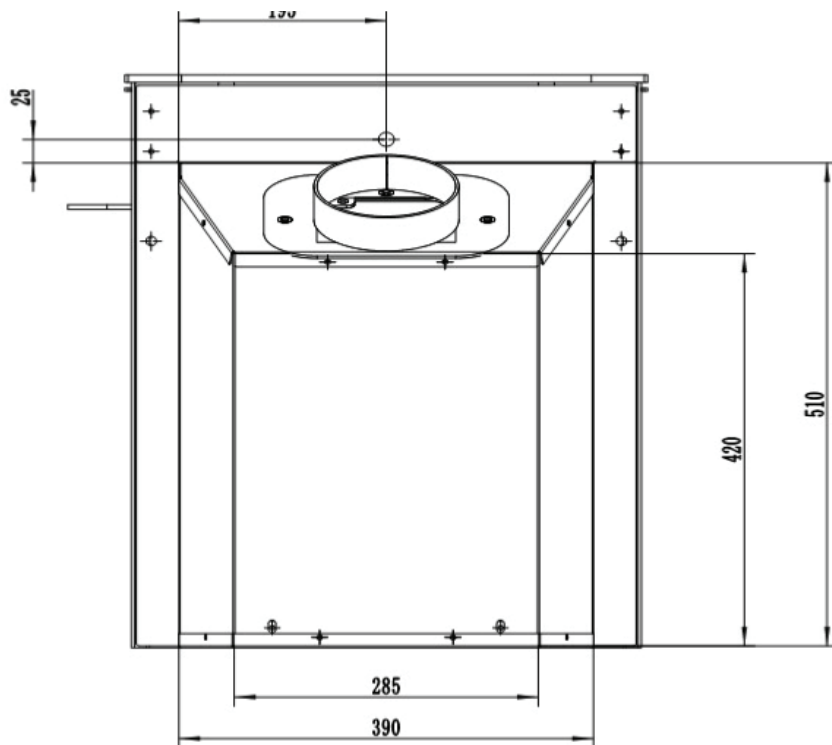
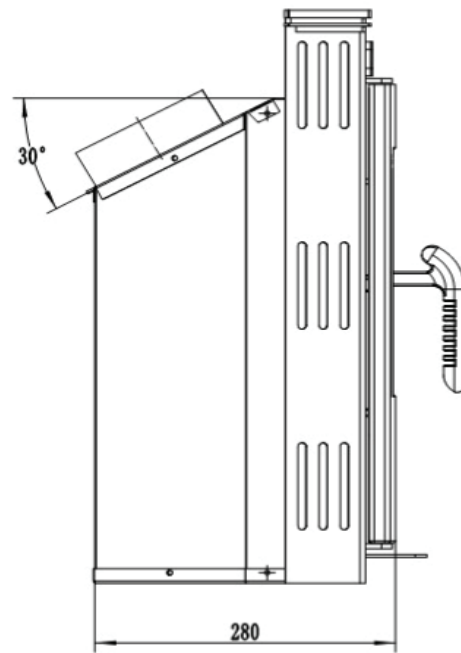
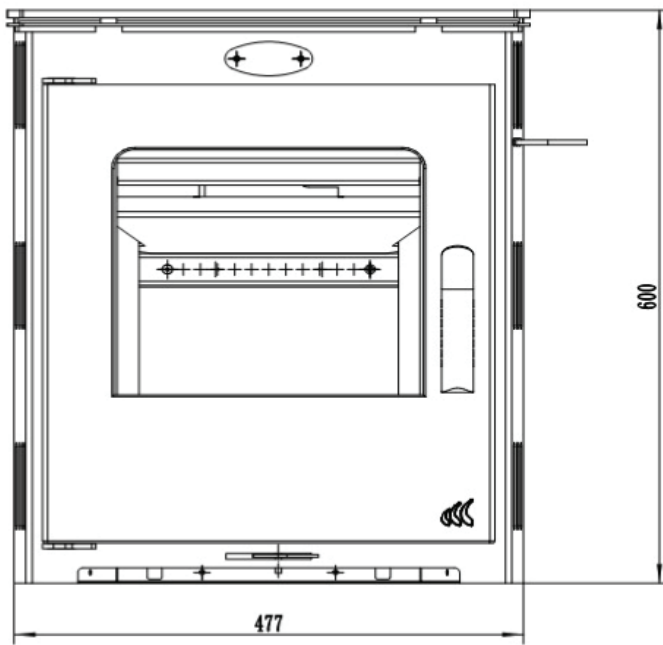



### Distance to Combustible materials

Combustible materials should not be located where the heat dissipating through the walls of fireplaces or flues could ignite it. Therefore when installing the stove in the presence of combustible materials due account must be taken of the guidance on the separation of combustible material given in Building Regulations Approved Document J and also in these stove instructions.

The minimum distances to flammable materials are specified on the EN 13240 plate on the back of the stove

	Distance to combustibles above	Distance to combustibles sides	Distance to combustibles sides Convection models	Suitable for 12mm non-combustible floor plate
Burcott	300mm	75mm	N/a	N/a

### Hearth

The hearth should be able to accommodate the weight of the stove and its chimney if the chimney is not independently supported.

The Burcott fireplace inset stove have been tested and are suitable to be installed on a constructional hearth only . Installation of all hearths should comply in size and construction so that it is in accordance with the provisions of the current Building Regulations Approved Document J.

The clearance distances to combustible material beneath, surrounding or on the hearth and walls adjacent to the hearth should comply with the guidance on the separation of combustible material given in Building Regulations Approved Document J and also in these stove instructions.

### Combustion air supply

In order for the stove to perform efficiently and safely there should be an adequate air supply into the room in which the stove is installed to provide combustion air. This is particularly necessary if the room is double-glazed or a flue draught stabiliser is operating in the same room as the appliance. The provision of air supply to the stove must be in accordance with current Building Regulations Approved Document J. An opening window is not appropriate for this purpose. Air inlets must be positioned in such a way that they cannot be blocked. An air inlet may be a vent (the vent must be open and the capacity for the vent sufficient when the stove is lit) .





### Mendip Stoves Insulated chambers

Mendip Burcott fireplace inset stove is lined with vermiculite heat deflection panels and a steel baffle, these panels are designed to ensure the maximum efficiency and are an integral part of the clean burn process of the stove. These vermiculite bricks should not be removed other than for cleaning the stove. Any defective panels should be replaced. Place fuel into the fire chamber of your stove, impact from logs can cause the heat deflection panel to crack.

### Connection to chimney

Mendip Burcott fireplace inset stove has a flue collar 30 degrees, this is to allow easier fitting of a flexible liner to the stove. Mendip stoves recommends the use of a stainless steel flue liner on all installations into a traditional chimney. Connect the stove collar to the flexible flue liner before installation of the stove and fit the collar back to the stove once the stove has been installed insitu.

### Commissioning and handover

Ensure loose parts are fitted in accordance with the instructions given in the instruction booklet. On completion of the installation allow a suitable period of time for any fire cement and mortar to dry out, a small fire may be lit to check that smoke and fumes are taken from the stove up the chimney and emitted safely into the atmosphere. Do not run at full output for at least 24 hours.

On completion of the installation and commissioning ensure that the operating instructions for the stove are left with the customer. Ensure to advise the customer on the correct use of the appliance with the fuels likely to be used in the stove and notify them to use only the recommended fuels for the stove.

Advise the user what to do should smoke or fumes be emitted from the stove. The customer should be warned to use a fireguard to BS 8423:2002 in the presence of children, aged and/or infirm persons.







## Operating your stove- Burcott fireplace inset

### Suitable fuels

Burcott model is tested to burn wood or smokeless coal. Wood briquettes and peat can also be burnt. For a full list of suitable fuels, check with the official solid fuels approvals body, HETAS or Solid Fuel Association. Do not overload stove as this can cause excessive heat and damage the stove( see table on page 3 ). **ALWAYS KEEP FUEL LOAD BELOW TERTIARY PORTS AT REAR OF STOVE.**

**Only use fuels approved for use on heating stoves.**

**Do not burn liquid fuels, drift wood, finished wood, sawn wood, pallet wood, chipboard/plywood ,varnished wood or plastic coated wood, wood treated with preservatives, or house hold waste. DO NOT EXCEED SPECIFIED FUEL WEIGHTS.**

**DO NOT BURN HOUSE COAL. DO NOT BURN HOUSEHOLD WASTE, THIS APPLIANCE IS NOT AN INCINERATOR.**

### The first lighting of your stove.

**Before lighting your stove for first time make sure you have read this manual fully and acquainted yourself with the controls of this appliance. (see page 12)**

The heat-resistant paint on your stove will cure and harden the first time you light your appliance. The curing process produces a good deal of smoke and odour, it is therefore important that the first time you light your stove the room should be well ventilated. During the process it is important to open and close the stove door periodically (every 30mins) during the first couple of firings therefore preventing the door seal cord around the door from sticking and coming away from the door. Once the heat-resistant paint has hardened the smell will disappear. This stove is NOT designed to be used with the door open, the stove door must be kept closed except when lighting the stove, adding firewood or removing ash in order to prevent flue gases from escaping.

### Lighting your appliance

Quality Firelighters should be used when lighting the stove. (Never use metholated spirit, petrol or other flammable liquids). Lighting your stove with firelighters will be more reliable and easier than using paper.

### TO LIGHT YOUR STOVE(wood)

1. Place a few smaller pieces of dry wood (kindling) in the stove on top of the non toxic firelighters, place one or two small dry split logs ( $\frac{1}{4}$  split) on top.
2. Fully open secondary air control. Fully open primary air control. The stoves air controls are now fully open.
3. Light the firelighters and push door to closed position.
4. Once the flames from the logs are fully established close primary air slider, this shuts off the primary air.
5. If the stove begins to choke and the chamber fills with smoke when the primary is fully closed, open primary control again until fire is established and then close.
6. Once established close the secondary air slider by 50%, for the stove to burn cleanly plenty of secondary air is needed, do not be tempted to shut the fire down too early as this may cause smoke. At nominal heat output, expect to refuel your stove approximately once an hour.

Check load weights for your model on the table on page 4.

The stove will get very hot during use and due care must therefore be exercised. Please use the glove and operating tool supplied when operating air controls and door.





### RE-FUELLING ( wood)

To re-fuel your stove in the cleanest way.

Only refuel your stove when flames have died down and you have glowing embers.

Before refuelling, open secondary air control fully .

Open door gently, add two pieces of wood (see weight table page 3) and close the door.

Once the flames from the logs are fully established the secondary air supply can be adjusted to the desired setting .

Operation with all air controls open can cause excess smoke. The appliance must not be operated with air controls, or door left open except as directed in the instructions. Use of flue dampers are not recommended.

### TO LIGHT YOUR STOVE (Solid Fuel)

Note: on cold days it maybe necessary to warm the flue using two firelighters.

1. Place Firelighters and a few smaller pieces of dry wood (kindling) among a small quantity of fuel in the combustion chamber.
2. Fully open the secondary air control. Fully open primary air below door of stove. The stove's air controls are now fully open. Light firelighters and securely close door.
3. With the fire established, open the door. And fill chamber with fuel, (see weight table on page 3) do not overload. (do not cover tertiary air ports). Reloading is approximately every 2 hours.
4. Close fire door, set primary air to 80% open and set secondary air to 40% open.
5. Adjust as necessary.

The stove is only suitable for intermittent use only: do not run overnight or for long periods unattended. Experience will determine the settings that produce best results. Use a stove door thermostat to check the stove is not overheating. Stove door thermostats should be placed directly above glass on door of the stove . The stove will get very hot during use and due care must therefore be exercised. Please use the glove and operating tool supplied when operating air controls and door.





### RE-FUELLING (Solid fuel)

To re-fuel your stove.

Before refuelling, open secondary and primary air controls fully.

Open door gently and de-ash your stove with use of poker. (not provided)

Add fuel to below tertiary air bar (see weight table on page 3) and close the door.

Leave the air controls open whilst fuel is established.

Set primary air to 80% open and set secondary air to 40% open.

In the event of a chimney fire: Close the air controls and the stove door, and call 999 or your local fire brigade.

If your stove is overheating close all air controls and ensure the door is firmly closed, leave appliance until the stove has returned to normal temperature.

### Incomplete combustion

If the air controls on your Burcott fireplace inset stove are closed too much incomplete combustion. This may lead to a build-up of hard, shiny soot on the inside of your stove and glass. To prevent sooting of the chamber and glass introduce:-

- 1) more secondary air,
- 2) check that your fuel is suitable and dry.
- 3) that you have sufficient draw in your chimney.

It is important to check the draft conditions before lighting your stove. This may be done, for instance, by crumpling a piece of newspaper, placing it in the combustion chamber and lighting it. The draft conditions are good if the smoke is drawn away through the chimney.

### WOOD FUEL

Good quality wood is the most important factor in your stove working efficiently and cleanly. Always use dry split hardwood firewood (moisture content of 20% or less). The dryness of the firewood plays an important role since the use of wet wood results in poor fuel economy and may cause a tarry sooty film on the internals of the stove.

Newly cut wood contains 60–70% water, making it totally unsuitable for use as firewood.

Newly cut wood should be stacked and air dried under cover for two years before being used as firewood.

**Do not burn liquid fuels, drift wood, finished, sawn wood, pallet wood, chipboard/plywood, varnished wood or plastic coated wood, wood treated with preservatives, or house hold waste.**

### SOLID SMOKELESS FUELS-

Burcott fireplace inset stove model is suitable for use with good quality smokeless fuels and have been fully tested to the relevant European standard. Only use registered smokeless fuels on this stove. Take special note of load quantities in front of this book.(page 4)

**HOUSE COAL AND PETROLEUM COKE ARE NOT SUITABLE FOR USE ON THIS STOVE; ITS USE WILL INVALIDATE THE GUARANTEE.**

### Overnight burning

Mendip stoves Ltd do not recommend burning coal in a slumbering position, Mendip stoves are designed to burn wood and quality registered smokeless fuels.

Wood burns more efficiently and cleanly if it is burnt hotter. Mendip stoves do not recommend that their stoves are burnt overnight for this reason.

As a night time regime we recommend that the fire is loaded when hot and burnt for five minutes with the secondary air control fully open until the new wood has taken and is burning, then close the secondary air valve to its operational position.

On returning to the stove in the morning the fire will have burnt out, reload with some paper or firelighter and some kindling and open both air sliders fully to relight quickly. Beware as the ash bed will have hot embers.

### Permanent air vent

The stove requires a permanent air vent to the room. This is to provide adequate air supply in order for the stove to operate safely and efficiently. In accordance with current Building Regulations the installer may have fitted a permanent air supply vent into the room in which the stove is installed to provide combustion air. This air vent should not under any circumstances be shut off or sealed.





## AIR CONTROLS

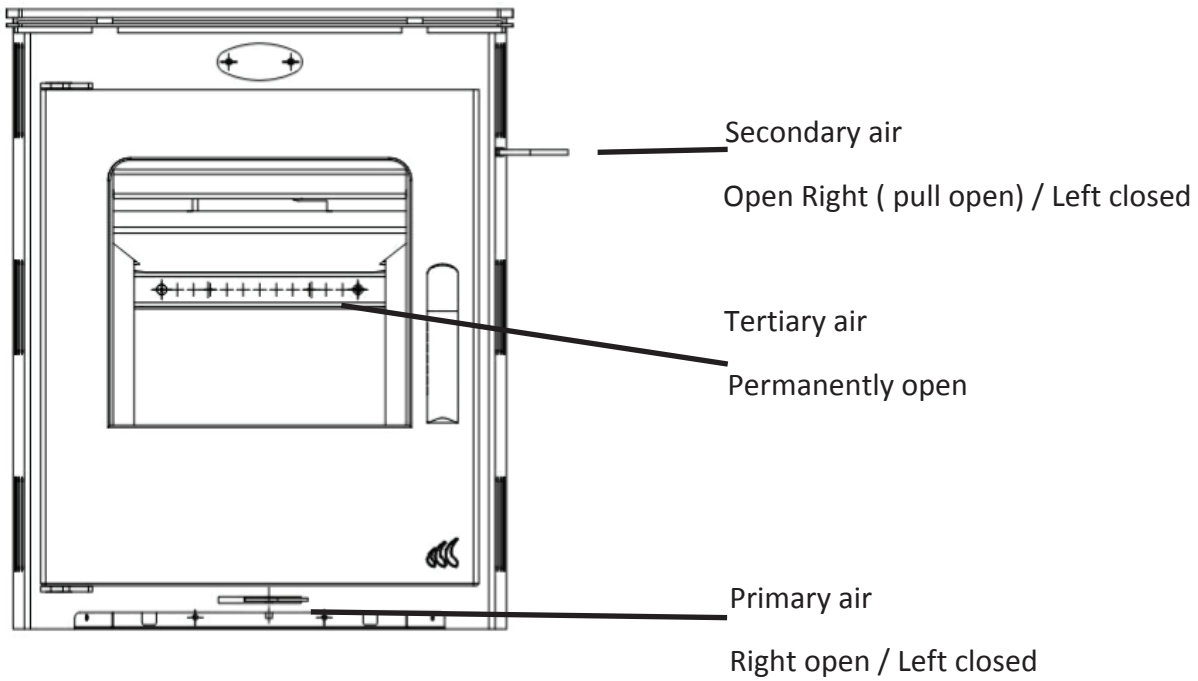

## DOOR OPERATION

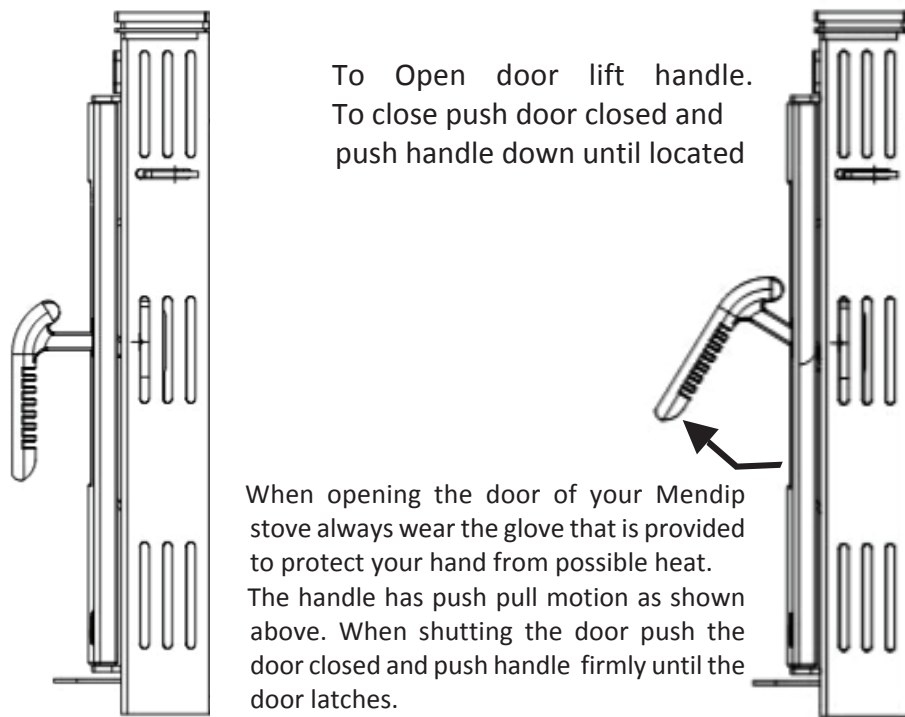

## PARTS

Always use the operating tools provided when handling parts likely to be hot when the stove is in use.

The Burcott Fireplace inset stove has the following tools and parts packed in the stove

- 1) Ash tray removal tool
- 2) Stove Glove
- 3) Instruction manual
- 4) Ash Pan





## Maintenance

Mendip stoves recommends that the Burcott fireplace inset stove model needs to have the ash removed from the stove at regular intervals (weekly if used daily). Allowing the ash pan to over flow can impede the function of the stove and can cause possible damage to the stove grate and ash pan. To remove ash pan use ash pan tool to hook under frontal loop on front of ash pan drawer. Lift and pull out of firebox chamber. Take care to support ash pan during movement, always wear a heat resistant glove. Make sure the stove is completely cold before cleaning out ash (embers can remain hot for over 24 hours).

Ash must be stored in a non-combustible container and must not be mixed with other combustible waste.

## Prolonged non use (summer)

If the stove is to be left unused for a prolonged period of time (e.g. over the summer) then it should be given a thorough clean to remove ash and unburned fuel residues. To enable a good flow of air through the appliance to reduce condensation and subsequent damage, leave the air controls fully open.

It is important that the flue connection, any appliance baffles or throat plates and the chimney are swept prior to lighting up after a prolonged shutdown period.

## Annual service

The inside of the stove should be serviced /cleaned once a year. To clean the inside, remove all ash, soot and tar residue from the combustion chamber. Remove insulated chamber panels and baffle, dirt and soot will collect behind it and this must be cleaned out. Check the quality of all insulated panels and replace any which are damaged or cracked, replace stove door rope cord in the door. Check glass is correctly positioned.

The stove, the flue pipe connection and the chimney should be checked regularly by a qualified engineer. The chimney should also be checked for blockages before relighting the stove if it has not been used for an extended period of time. The paint/ lacquer can wear thin in exposed places due to overheating. This, and other lacquer damage, may be repaired using Senotherm paint/lacquer spray available from your Mendip dealer. To clean the outside of the stove use a dry cloth.

## Sweeping your chimney

Ensure that your appliance, flue ways and chimney are swept regularly. This can be incorporated in the service regime of your appliance. Regular sweeping is essential and means at least once a year for smokeless fuels and a minimum of twice a year for bituminous coal, wood or any other non-authorized/smoke fuel. If a throat plate is incorporated, it is essential that the throat plate is removed and cleaned above, all ash and debris should be removed. Ensure adequate access to cleaning doors where it is not possible to sweep the chimney through the appliance.

Where a chimney has served an open fire installation previously it is possible that the higher flue gas temperature from a closed appliance may loosen deposits that were previously firmly adhered, with the consequent risk of flue blockage. It is therefore recommended that the chimney be swept a second time within a month of regular use after installation of the stove.

## Aerosols

**Aerosols are flammable and therefore dangerous to use around a lit stove. Do not use aerosol sprays near your lit stove. The use of any aerosol is dangerous and care must be taken in handling aerosols.**

## Warning Note

Properly installed, operated and maintained this stove will not emit fumes into the dwelling. Occasional fumes from de-ashing and re-fuelling may occur. However, persistent fume emission is potentially dangerous and must not be tolerated. If fume emission does persist, then the following immediate action should be taken:-

- (a) Open doors and windows to ventilate the room and then leave the premises.
- (b) Let the fire go out.
- (c) Check for flue or chimney blockage and clean if required
- (d) Do not attempt to relight the fire until the cause of the fume emission has been identified and corrected. If necessary seek expert advice.

The most common cause of fume emission is flueway or chimney blockage. For your own safety these must be kept clean at all times.

## CO Alarm

Your installer should have fitted a CO alarm in the same room as the appliance. If the alarm sounds unexpectedly, follow the instructions given under "Warning Note" above.





## Trouble shooting

### 1. Fire Will Not Burn - check

- a) the air inlet is not obstructed in any way,
- b) that chimney and flue ways are clear,
- c) that a suitable fuel is being used,
- d) that there is an adequate air supply into the room,
- e) that an extractor fan is not fitted in the same room as the fire.

### 2. Fire Blazing Out Of Control - check

- a) the doors are tightly closed,
- b) the air controls are turned down to the minimum setting,
- c) the flue damper is closed ( if fitted),
- d) a suitable fuel is being used,
- e) the door seals are in good condition.
- f) the chimney draft may be too strong
- g) check ash pan seal and
- h) check for ash below ash pan causing pan to seat incorrectly and clean out.

### 3) Soot forms on the window

- a) The firewood may be too wet
- b) the intake of secondary air may be insufficient
- c) fire not hot enough

### 4) The stove fails to heat fully

- a) The firewood may be too wet
- b) the intake of secondary air may be insufficient

### 5) Smoke or odour

- a) Weak chimney draft
- b) check for blockages in the flue pipe/chimney
- c) check the height of the chimney relative to the surroundings

### 6) Soot in the chimney

- a) The firewood may be too wet
- b) intake of secondary air may be insufficient

## Chimney Fires

If the chimney is thoroughly and regularly swept, chimney fires should not occur. However, if a chimney fire does occur turn the air control setting to the minimum, and tightly close the doors of the stove. This should cause the chimney fire to go out in which case the control should be kept at the minimum setting until the fire in the stove has gone out. The chimney and flue ways should then be cleaned. If the chimney fire does not go out when the above action is taken then the fire brigade should be called immediately.

After a chimney fire the chimney should be carefully examined for any damage. Expert advice should be sought if necessary



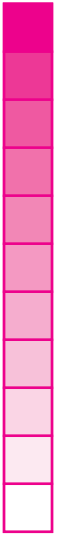

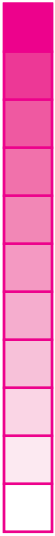

Mendip Stoves Ltd  
Unit H2,  
Mendip Industrial Estate,  
Mendip Road, Rooksbridge, Somerset  
BS26 2UG  
  
Mendip Stoves Ltd, 2013, Burcott v3 2013

Tel: 01934 750 500  
Fax: 01173 156 207  
[www. Mendipstoves.co.uk](http://www.Mendipstoves.co.uk)  
E-mail : [info@mendipstoves.co.uk](mailto:info@mendipstoves.co.uk)

