

‘Wraith’ Pebble & Log Effect Inset Decorative Electric Fire

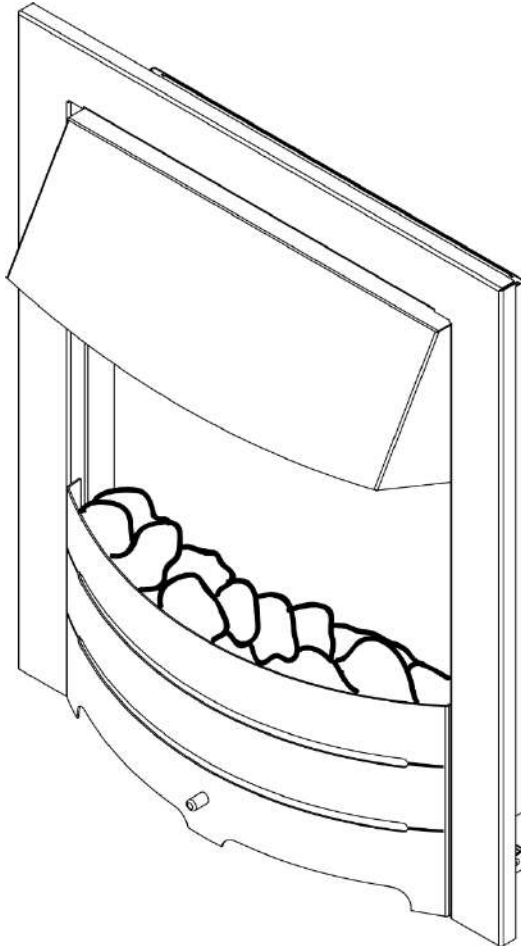

Users Operating Instructions

Having installed the appliance, the installer should take the necessary steps to ensure that the user fully understands how to operate the appliance and is also made aware of the fire's basic cleaning and maintenance requirements.

“This Product is only suitable for well insulated spaces or occasional use.”

INSTALLATION REQUIREMENTS

IMPORTANT - PLEASE READ BEFORE USING YOUR PRODUCT

1. This product must be left in its final position for at least one hour to acclimatise to your room temperature before use.
2. Do not position this product near to a bath, shower or a swimming pool.
3. Under no circumstances must this product be covered with anything. This is a serious fire risk.
4. Do not position this product below a socket outlet, and ensuring it is positioned so that the plug socket is easily accessible.
5. Position so that the product is situated on a flat surface. It is strongly recommended that the product is not situated on a carpet or any other textile surface.
6. This product must be securely fixed to a wall see Installation instructions.
7. Do not use this product in series with a programme controller, thermal control, a timer or any other device that switches the fire on automatically.
8. Do not seal fire in with silicone or any other similar products.
9. This appliance can be used by children from 8 years old and above and persons with reduced physical, sensory or mental capabilities or lack of experience and knowledge if they have been given supervision or instruction concerning use of the appliance in a safe way and understand the hazards involved. Children shall not play with the appliance. Cleaning and user maintenance shall not be made by children without supervision. Children of less than 3 years should be kept away unless continuously supervised. Children aged from 3 years and less than 8 years shall only switch on/off the appliance provided it has been placed or installed in its intended normal operating position and they have been given supervision or instruction concerning use of the appliance in a safe way and understand the hazards involved. Children aged from 3 years and less than 8 shall not plug in, regulate and clean the appliance or perform user maintenance.

CAUTION – Some parts of this product can become very hot and cause burns. Particular attention has to be given where children and vulnerable people are present.

WARNING: Do not use this heater in small rooms when they are occupied by persons not capable of leaving the room on their own, unless constant supervision is provided.

WARNING: This appliance must be earthed. Refer to the rating plate for the voltage.

IMPORTANT:

The wires in the mains lead fitted to this appliance are coloured in accordance with the following code:

GREEN / YELLOW - EARTH
BLUE - NEUTRAL
BROWN – LIVE

If you have to fit a plug:

As the colours of the mains lead of this appliance may not match the coloured markings used to identify the terminals in a plug, please observe the following:

- The green and yellow wire must be connected to the terminal in the plug which is marked with the letter E or the earth symbol
- The blue wire must be connected to the terminal in the plug marked with the letter N.
- The brown wire must be connected to the terminal in the plug marked with the letter L.

Legendfires 

- If the plug or the supply cord is damaged it must be replaced by a new cord or assembly available from the manufacturer or service agent.

- Replace fuses only with fuses of the correct size and rating.

Electrical Connections

This appliance must only be connected to a 230/240 volts AC 50Hz supply. Before connecting the fire, check that the supply voltage is the same as stated on the fire. This appliance must only be used on AC supply fuse rating 13 amps.

Electra

Please note:

Recommended inset opening is 415mm wide x 555mm high x 80mm deep.

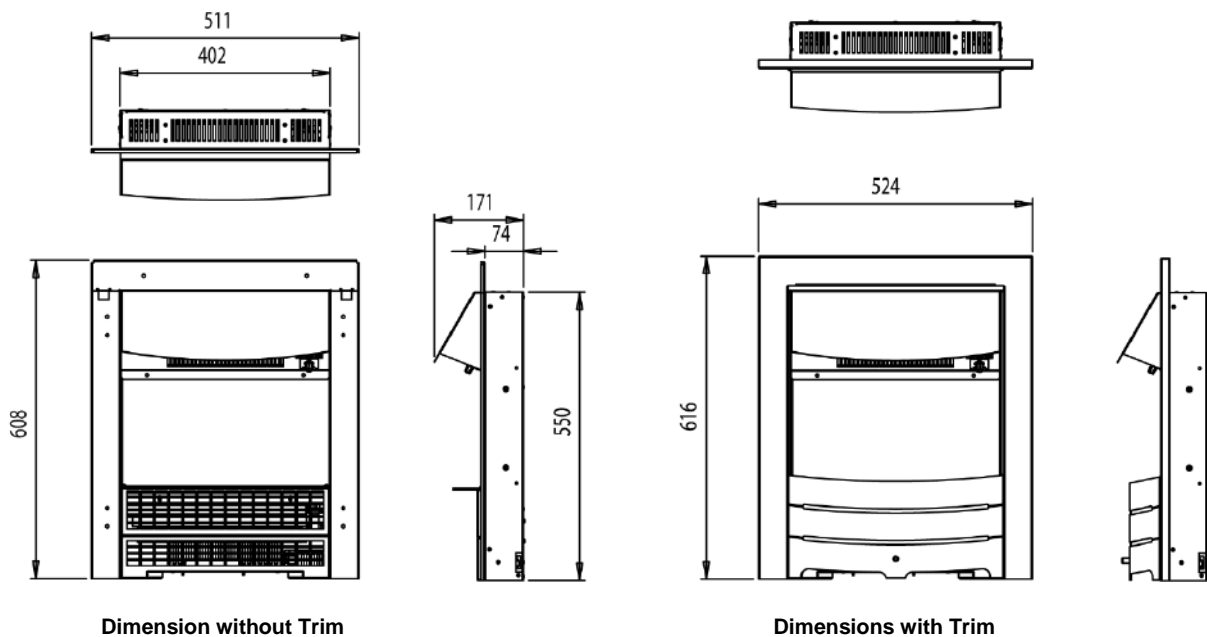

INSTALLATION INSTRUCTIONS

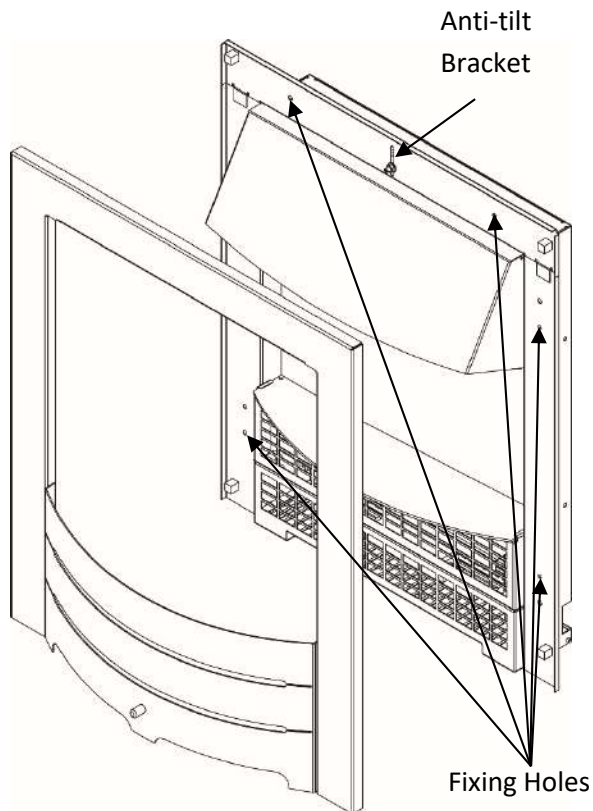

Remove the fire trim and position the fire in the desired location secure the fire to the wall, using suitable fixings in the six fixing holes provided in the fire flange, an anti-tilt bracket is fitted to the top of the fire to be used when fitting in an existing fireplace, when secure re-fit the fire trim and place the loose coals, pebbles onto the coal support as shown.

Note

If the fire is being used in an existing fireplace, it is important that the chimney is blocked off to prevent downward draughts and falling debris. This can be achieved by inserting mineral wool into the chimney and covering with a piece of board into the chimney opening above the appliance.

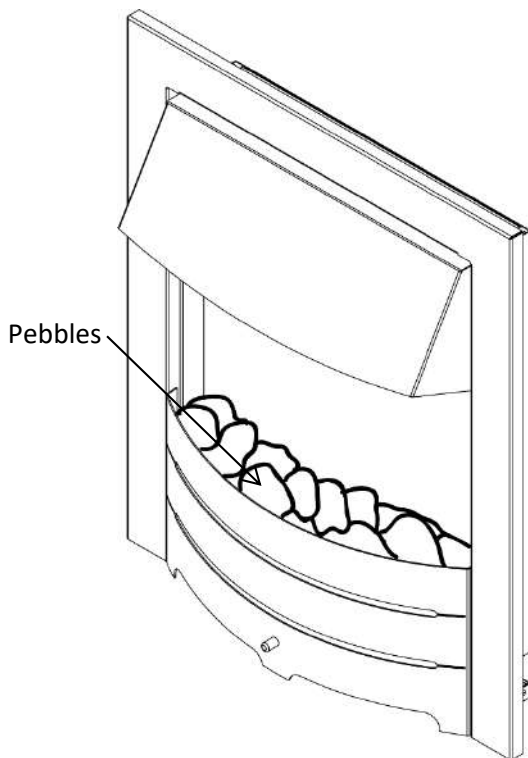

USER INSTRUCTIONS

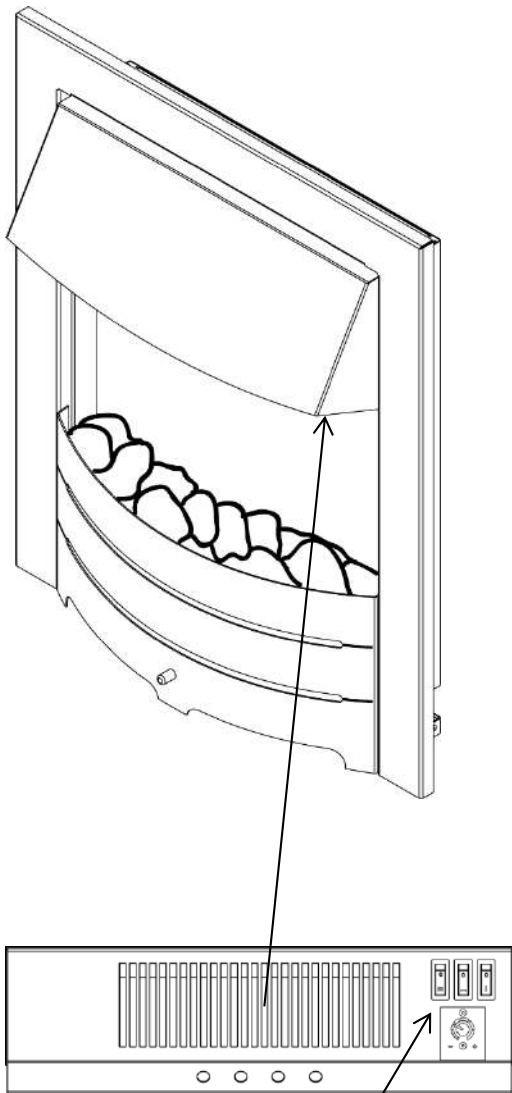
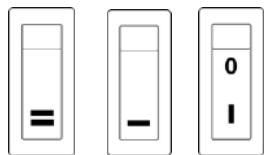

Fig.1



2kw Fan Switch 1kw Fan Switch On/Off Switch



Temperature Control Switch





Plug in the fire and ensure it is switched on at the mains.

To operate the fire (Fig. 1)

Ensure the  switch is in the on (I) position. This will illuminate the fire when no heat is required.

This switch will also need to be on to use any of the elements.

To operate the 1kW fan press switch .

To operate the 2kW fan press both switches  & .

The room temperature can be set by adjusting the heat temperature control switch up or down, this will automatically turn the 1&2kW fans on and off to maintain the room temperature at the desired level. Note the 1kW fan switch must be switched on to operate the temperature control switch

Fan unit cut-out

The fire will automatically cut-out to prevent damage from overheating. If the airflow is obstructed or restricted in anyway; the heater will automatically switch off. Switch the fire off (0) and after a suitable cooling period remove the obstruction. Switch fire on (I) again.

Important notes on Fan Heaters

You may experience a low volume noise due to air flow through the fan and the blower. This is quite normal and in no way impairs the working of the appliance.

SERVICING

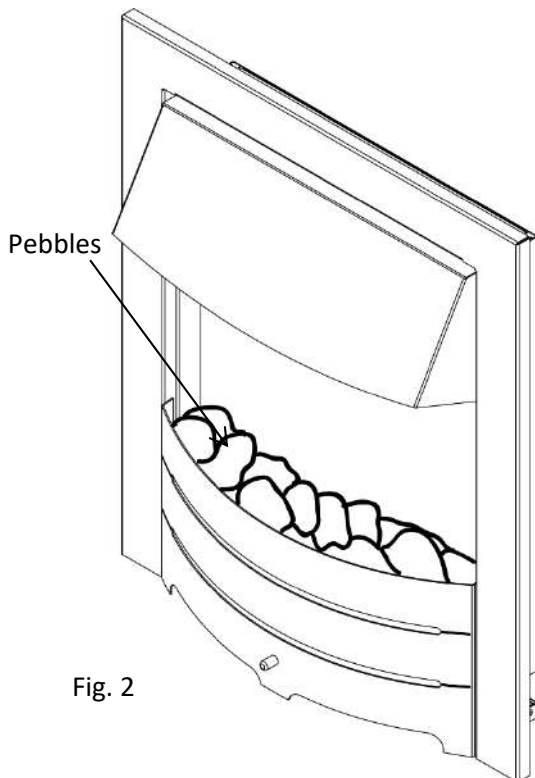

Fig. 2

Servicing the fire

Only a competent person should service this appliance. It is recommended that the appliance should be serviced every 12 months.

WARNING: Before carrying out servicing, ensure that the power supply cord is removed from the mains wall socket.

Cleaning the appliance

Unplug the fire from the mains socket.

Remove the loose Pebbles / Logs. (fig.2)

Remove the frame and ash pan to reveal the mesh support. (fig.3)

Vacuum the front mesh to remove any dust.

Clean Fire with a damp soft cloth. Do not use polish or abrasives.

Reassemble in reverse order.

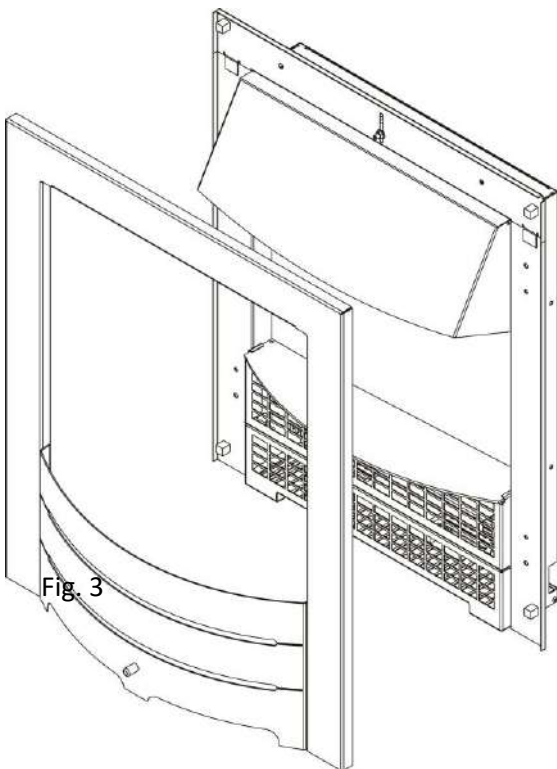

GUARANTEE

CONDITIONS OF WARRANTY

If this appliance should prove to be defective due to faulty design, materials or workmanship within 12 months of purchase, the product will be repaired free, subject to the following conditions.

1. The electric fire shall have been purchased and used solely within the UK for domestic purposes and in accordance with the Users Operating instructions.
2. It is the purchaser's responsibility to prove that the unit is under guarantee, e.g. receipt of purchase.
3. On discovery of a fault, the purchaser should contact the dealer from whom the product was purchased in order to ascertain whether they or a service centre will carry out the repair. If problems are encountered the purchaser may contact the service centre shown on the list enclosed with this product. All transportation will be at the purchaser's expense and risk.
4. All guarantees will be invalidated if unauthorised repairs or modifications are made to the electric fire, or in case of accident, misuse, or damage caused by improper installation, or to damage occurring during transit to or from the repairer and altered or missing serial numbers.
5. Any parts, which have been replaced under this guarantee, shall become our property.
6. The company shall not be liable for any consequential loss or damage whatsoever, arising from or in connection with this electric fire.
7. This guarantee does not apply to elements, bulbs or fuses.
8. 'No fault found', service calls and installation errors are not covered under the Manufacturers guarantee and will result in a charge being made for the call out by our appointed service engineer.
9. This guarantee is in addition to and does not affect the purchaser's statutory rights of Consumers.
10. The company will arrange call-out requests within a mutually agreed time frame. If the companies appointed engineer cannot gain access or receives no answer, a call-out charge will be incurred.
11. The company reserve the right to alter, change and amend or cancel any aspect of these terms & conditions in whole or part without prior notice.

PLEASE COMPLETE THIS CARD AND RETURN TO REGISTER YOUR WARRANTY

Your Details

Mr/Mrs/Miss/Ms:

Address

Town/City:

County:

Post Code:

Telephone Number:

Product Details

Model Name:

Serial Number:

Purchased From:.....

Installation Date:

I confirm that I have read and understood the terms & conditions listed above and agree to abide by these terms & conditions.

Signature:

For Office use only

Date Card Received

Date Warranty Activated:

BDS/10

Date:

Please tick this box, if you do not wish to be contacted by our authorised service agents regarding future service and maintenance requirements.

Legendfires 

IMPORTANT WARRANTY INFORMATION

Please retain these details for future reference.

For you records

Model Name:

Serial Number:

Purchased from:

Installation Date:

SERVICE RECORD

	Company	Engineers Signature	Date
1 st Service			
2 nd Service			
3 rd Service			
4 th Service			
5 th Service			



Unit 404
 Glenfield Park Business Centre
 Blakewater Road
 Blackburn
 Lancashire
 BB1 5QH
 Tel: 01254 695244
 Fax: 01254 695255
 Web: www.legend-fires.com
 Email: info@legend-fires.com

PLEASE COMPLETE THIS CARD AND RETURN TO REGISTER YOUR WARRANTY

**LEGEND GAS FIRES LTD
 UNIT 404
 GLENFIELD PARK BUSINESS CENTRE
 BLAKEWATER ROAD
 BLACKBURN
 LANCASHIRE
 BB1 5QH**

AFFIX
STAMP
HERE

