

Installation & Operating Instructions



Covering Models:

Ignite 5, 6 & 7

Desire 5, 6 & 7

Hereford 5, 6 & 7

Standard & Log Store Multifuel Stoves

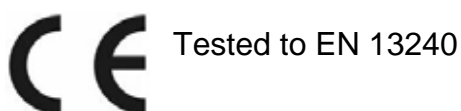

These appliances must be installed and commissioned by a HETAS registered engineer

Contents

Introduction	3
Packing List	3
Health & Safety	4
Specifications	5
Dimensions	6
Hearth Requirements & Clearances	10
Chimney Requirements	11
Combustion Air Requirements	12
Assembly	
Smoke Control Area Modification	13
Log Store Base	15
Internal Companints	16
Stove Operation	
Controls Layout	17
Controls Explained	18
Air wash System	18
Ash Pan	18
Recommended Fuels	19
Lighting the Stove	
Kindling Stage	20
Burning Wood & Burning Coal	21
Smoke Control Areas	22
Warning Notes	24
Maintenance	
Door Adjustment	25
Ash Removal	26
Cleaning the Stove	26
Glass Cleaning	26
Chimney Sweeping	26
Chimney Fires	26
Stove Servicing	26
Trouble-shooting	27
Commissioning Form	28
Spare Parts	29
Annual Service Record	30
Warranty	31

Introduction

Thank you for choosing one of our multifuel stoves.

The term multifuel refers to the fact that the appliance is capable of burning either wood logs or coal (that is suitable for closed appliances). Both of these fuels have very different air requirements in order for them to burn correctly, therefore the air controls need to be operated differently depending on the fuel being burned (see section “Stove Operation”).

See the section “Lighting the Stove” for further details. After reading this document, if there is anything you are unsure about, please contact your dealer or our Technical Support Department.

These instructions cover the basic principles to ensure the satisfactory installation of the stove, although detail may need slight modification to suit particular local site conditions. In all cases the installation must comply with current Building Regulations, Local Authority Byelaws and other specifications or regulations as they affect the installation of the stove.

It should be noted that the Building Regulations requirements may be met by adopting the relevant recommendations given in British Standards BS 8303 and BS EN 15287-1 2007 + A1 2010 as an alternative means to achieve an equivalent level of performance to that obtained following the guidance given in Approved Document J.

Please note that it is a requirement under the Broseley Fires warranty system that the installation of the stove is carried out by a Competent Person registered with a Government approved Competent Persons Scheme. HETAS Ltd operate such a Scheme and a listing of their Registered Competent Persons can be found on their website at www.hetas.co.uk.

Packing List

1x Steel Body stove	2x Steel side firebricks	1x Log Retainer
1x Multifunction Tool	1x Steel rear firebrick	1x Air Intake Spigot
1x Instruction booklet	1x Steel baffle	1x Blanking Plate
1x Heat Proof Gloves Set	1x Cast iron grate	
1x Spigot (flue collar)	1x Steel Ash pan	

All parts will be inside the main stove body upon delivery. The spigot will generally be bolted to the outside of the stove body.

Health & Safety

Special care must be taken when installing the stove such that the requirements of the Health and Safety at Work Act are met.

Installation

This appliance **MUST** be installed and commissioned by a HETAS registered installer in England and Wales and a fully qualified Heating Engineer in Scotland and Ireland.

Handling

Adequate facilities must be available for loading, unloading and site handling.

Fire Cement

Some types of fire cement are caustic and should not be allowed to come into contact with the skin. In case of contact, wash immediately with plenty of water.

Asbestos

This stove contains no asbestos. If there is a possibility of disturbing any asbestos in the course of installation then please seek specialist guidance and use appropriate protective equipment.

Metal Parts

When installing or servicing this stove care should be taken to avoid the possibility of personal injury.

CO Alarms

Building regulations require that whenever a new or replacement fixed solid fuel or wood/biomass appliance is installed in a dwelling an audible carbon monoxide alarm must be fitted in the same room as the appliance. Further guidance on the installation of the carbon monoxide alarm is available in BS EN 50292:2002 and from the alarm manufacturer's instructions. Provision of an alarm must not be considered a substitute for either installing the appliance correctly or ensuring regular servicing and maintenance of the appliance and chimney system.

Fire Guards

When using the stove in situations where children, aged and/or infirm persons are present a fireguard must be used to prevent accidental contact with the stove. The fireguard should be manufactured in accordance with BS 6539.

Aerosol Sprays

Do not use an aerosol spray on or near the stove when it is alight.

Operating Tool & Gloves

Always use the operating tool and glove provided when handling parts likely to be hot when the stove is in use. The tool provided allows you to operate the handle and air controls.

Specifications

In the UK these stoves have been approved by HETAS Ltd as intermittent heating appliances for burning coal suitable for a closed appliance and wood logs only.

	Ignite, Desire & Hereford 5 (Q5)	Ignite, Desire & Hereford 6 (Q6)	Ignite, Desire & Hereford 7 (Q7)
Nominal Heat Output (Wood) kW	5	6	7.3
Nominal Heat Output (Ancit) kW	4.9	6	7.4
Efficiency (Wood) %	82.9	79.4	79.4
Efficiency (Ancit) %	81.1	81.1	83.4
Weight Kg	Ignite 5 71 Ignite 5 LS 85 Desire 5 68 Desire 5 LS 82 Hereford 5 66	Ignite 6 78 Ignite 6 LS 93 Desire 6 74 Desire 6 LS 90	Ignite 7 84 Ignite 7 LS 101 Desire 7 80 Desire 7 LS 97 Hereford 7 77
Flue Diameter mm	125	125	125
Flue Diameter Inches	5	5	5
Flue Draft Min Pa	12	12	12
Flue Draft Max Pa	18	18	18
Flue Temp (Wood) °C	239	290	290
Flue Temp (Ancit) °C	210	237	237
CO Emission (@ 13% O ² Wood) %	0.46	0.46	0.29
CO Emission (@ 13% O ² Ancit) %	0.54	0.54	0.40
Flue Mass Flow (Wood) g/s	3.2	5.2	5.2
Flue Mass Flow (Ancit) g/s	3.6	4.7	4.7
Fuel Consumption Per Hour (Ancit)	0.7 Kg	0.9 Kg	1.1 Kg
Fuel Consumption Per Hour (Wood)	1.4 Kg	1.7 Kg	2.1 Kg

Please note the figures above are without the Smoke Control area spacer fitted, this modification is required when installing the appliance in a smoke control area. The spacer will affect these figures, please see the Smoke Control Area section for the alternate figures. Details on fitting the smoke washer can be found in the Assembly section – THE MODIFICATION MUST BE MADE PRIOR TO FINAL SITING AND CHIMNEY CONNECTION.

European standards need to be complied to when installing this appliance.

Dimensions

Ignite 5 & Desire 5

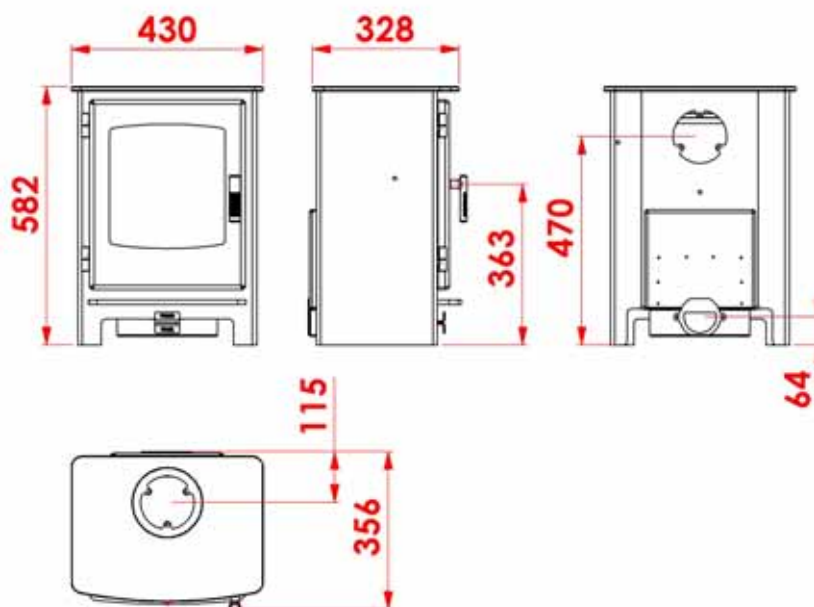

Ignite 5 & Desire 5 Log Store

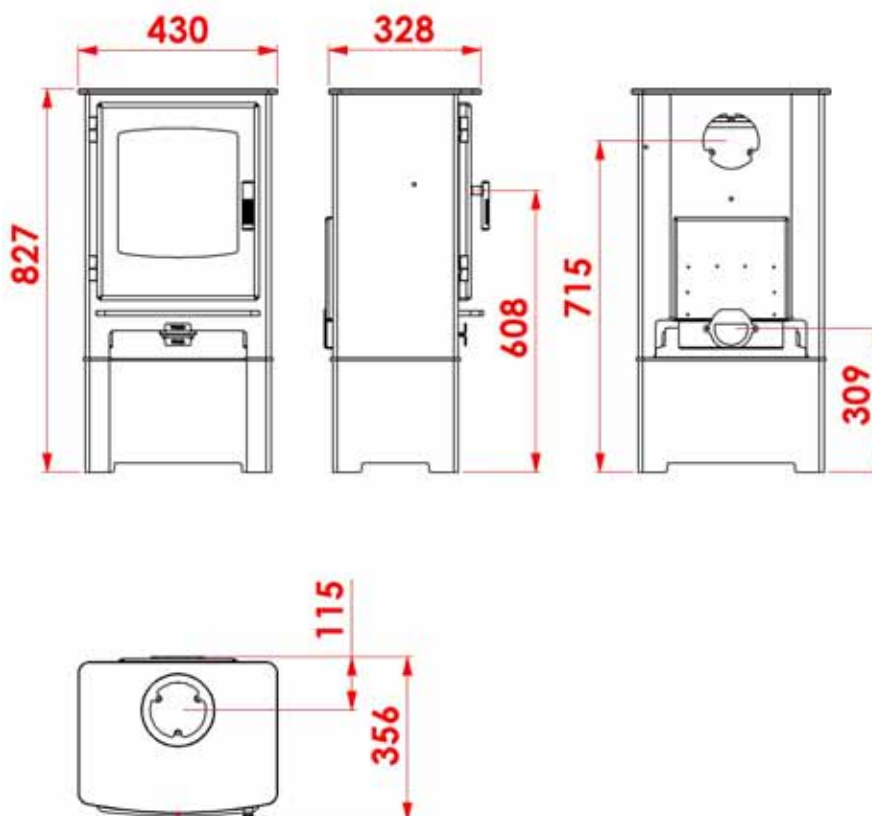

Dimensions

Ignite 6 & Desire 6

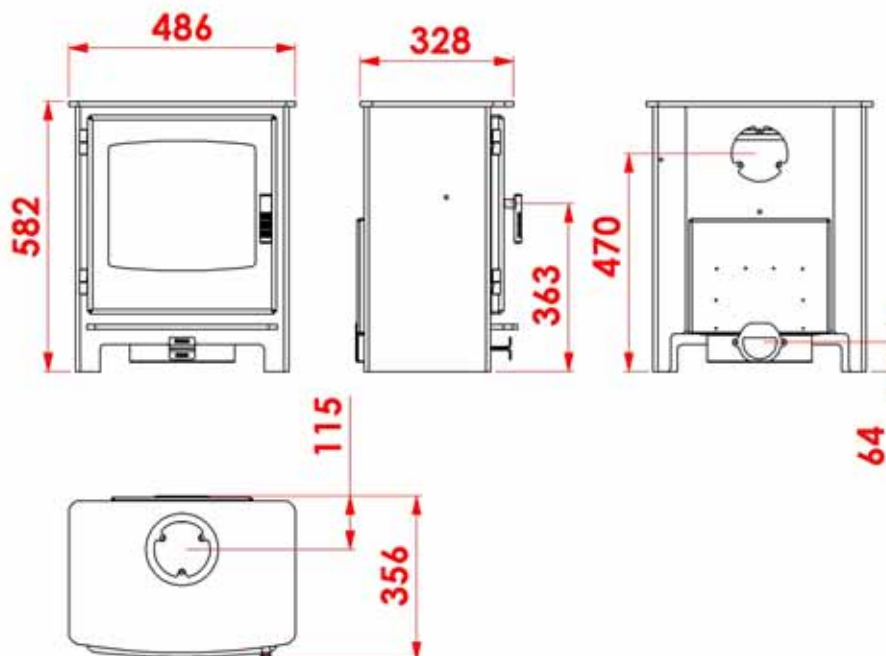

Ignite 6 & Desire 6 Log Store

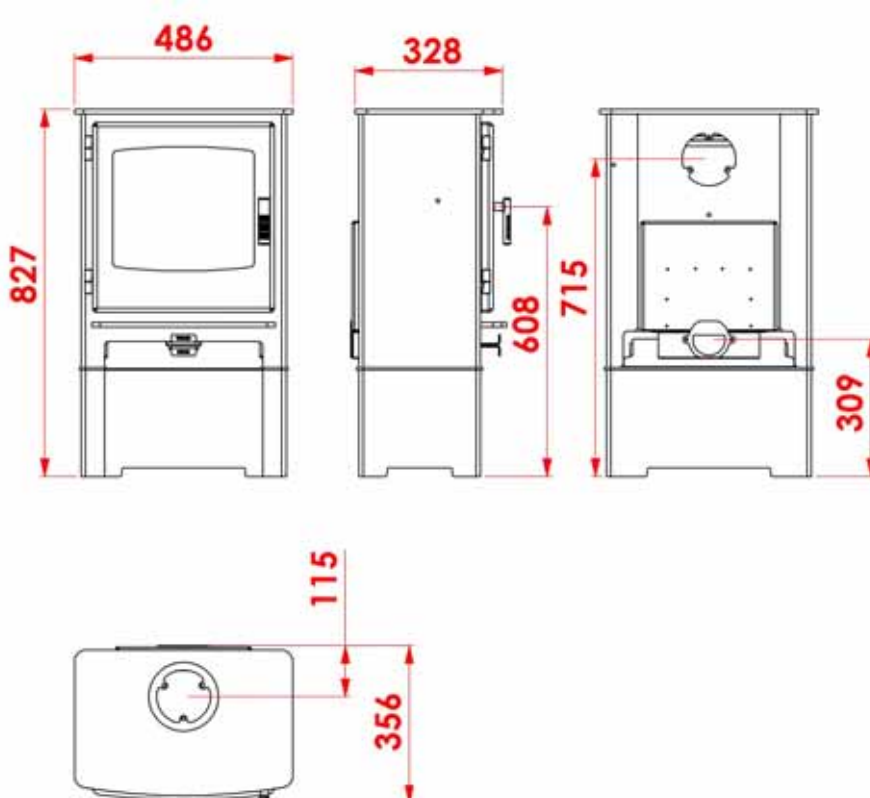

Dimensions

Ignite 7 & Desire 7

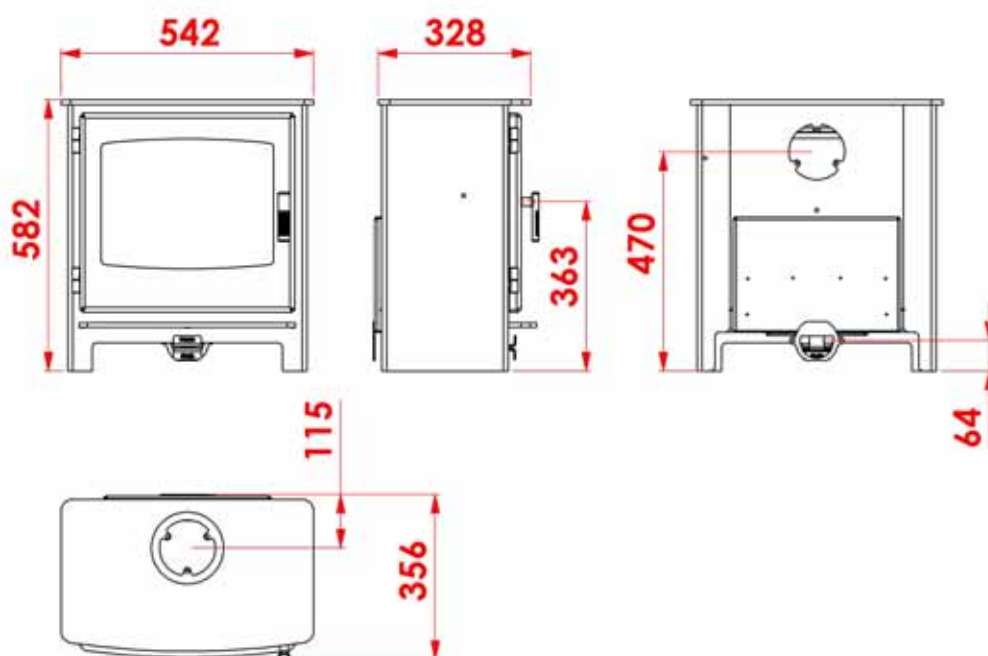

Ignite 7 & Desire 7 Log Store

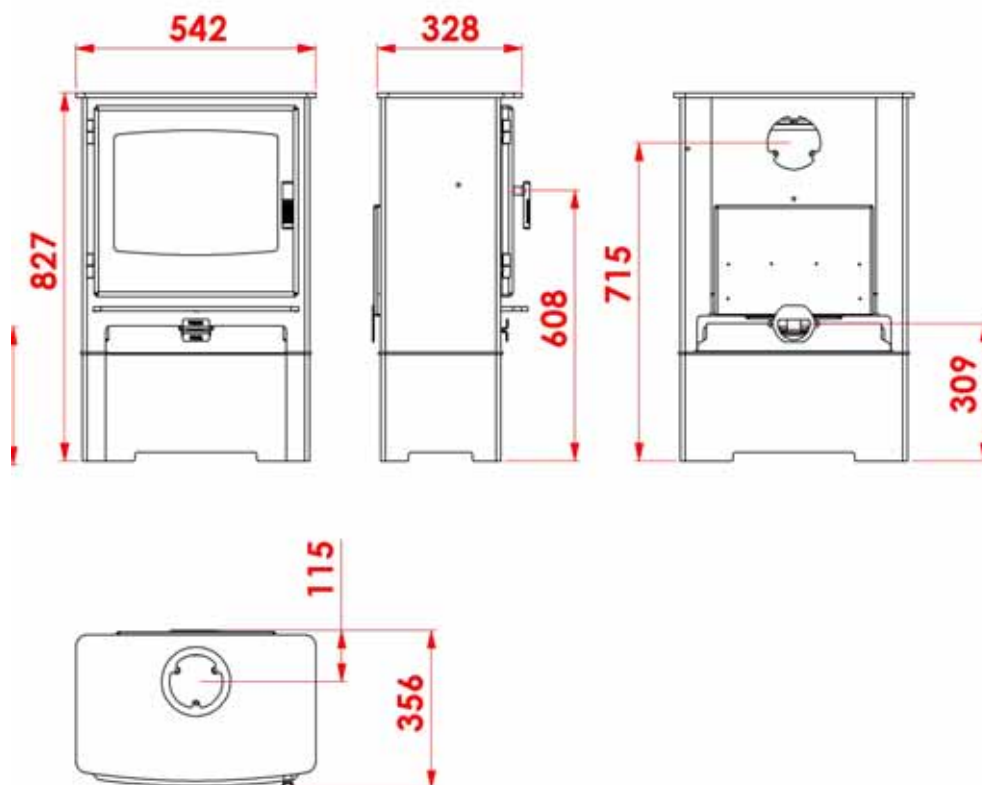

Dimensions

Hereford 5

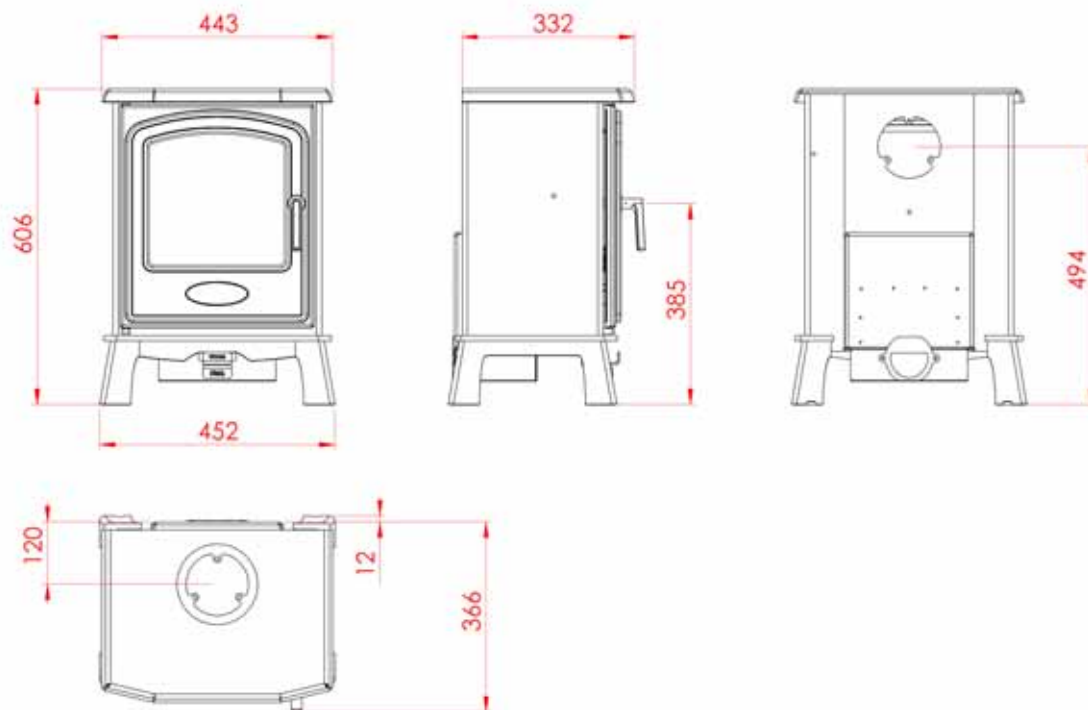

Hereford 7

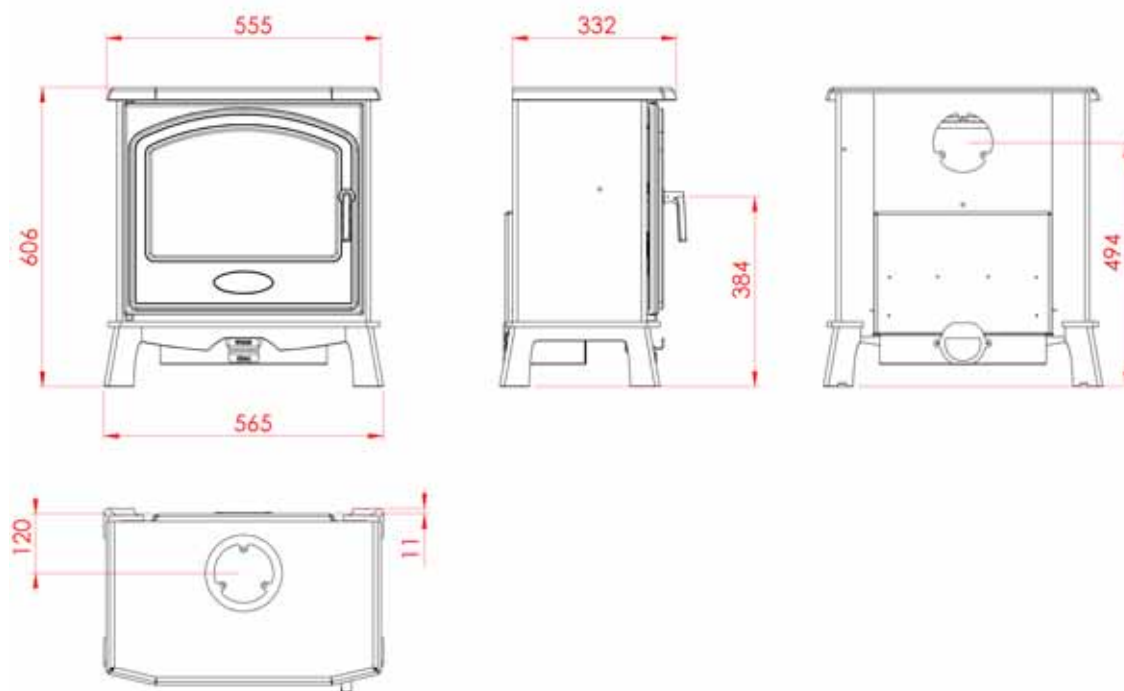

Hearth Requirements & Clearances

The standard (without log store) appliances require a full constructional hearth with sub-hearth as laid out in building regulations approved document J. Log store versions are suitable for a minimum 12mm thick hearth.

Your stove must be installed on a solid, level non-combustible hearth. The hearth protrusion in front of the stove to carpets or wooden floors must be at least 300mm. As it is possible, that on opening the door of the stove for fuel to fall out, a fender must be fitted if the hearth is flush with the carpet.

Clearances

The stove requires the following minimum clearances around it to ensure the heat is released into the room and to allow sufficient combustion air flow. A combustible material clearance is given to prevent damage to any items that may be affected by heat.

Product	Material	Rear	Side	Hearth	Above
Ignite, Desire & Hereford 5 (Q5)	Combustible	725mm	550mm	300mm	600mm
	Non-combustible	100mm	100mm	300mm	100mm
Ignite, Desire & Hereford 6 (Q6)	Combustible	725mm	550mm	300mm	600mm
	Non-combustible	100mm	100mm	300mm	100mm
Ignite, Desire & Hereford 7 (Q7)	Combustible	650mm	500mm	300mm	600mm
	Non-combustible	100mm	100mm	300mm	100mm

Please note these are minimum clearances and may not provide sufficient space in your installation to provide adequate access for maintenance. Ideally you want as much space around the product as possible to provide access at service intervals.

Chimney Requirements

This appliance must not be fitted into a chimney serving another heating appliance. It is most important that there is no obstruction in the flue or chimney. Please ensure that any existing chimney is clear of obstruction and swept clean immediately before installation of the new stove. If the chimney has been used for an open fire it is recommended that it be swept for a second time having been used for a month following installation.

A flue draught minimum of 12 Pascals to a maximum 18 Pascals is required for satisfactory appliance performance. A properly built masonry or factory constructed chimney (with a minimum vertical height of 5 metres) should ensure a consistent draught (draw). 45° bends can be used in the flue run (maximum of four bends) you will need to add an extra 1 metre of vertical flue height for each bend.

The flue draught should be checked under fire at high output and if it exceeds the recommended maximum, a draught stabiliser must be fitted so that the rate of burning can be controlled, and to prevent over firing (See section "Warning Notes"). If you have any doubts about the suitability of your chimney, consult your local dealer/stockist or engineer. If your flue draft is below the minimum recommendation then it may be necessary to increase the vertical chimney height, add additional flue insulation or possibly add a special cowl to the top of the chimney (e.g. anti down draft cowl to eliminate wind induced down draft).

The outlet from the chimney should be above the roof of the building in accordance with the provisions of Building Regulations Approved Document J.

If installation is into an existing chimney then it must be sound and have no cracks or other faults which might allow fumes into the house. Older properties, especially, may have chimney faults or the cross section may be too large i.e. more than 230 mm x 230 mm. Remedial action should be taken, if required, seeking expert advice, if necessary. If it is found necessary to line the chimney then a flue liner suitable for solid fuel must be used in accordance with Building Regulations Approved Document J.

If there is no existing chimney then either a prefabricated block chimney in accordance with Building Regulations Approved Document J or a twin walled insulated stainless steel flue to BS 4543 can be used. These chimneys must be fitted in accordance with the manufacturer's instructions and Building Regulations.

If a flexible liner is required the liner diameter must not be less than 5" / 125mm.

Any bend in the chimney or connecting fluepipe should not exceed 45°. 90° bends are not permitted. For top flue installations it is possible to sweep through the appliance by removing the internal baffle however it is recommended that you provide adequate access (e.g. easily accessible soot door). For rear flue connection we recommend the use of a tee section, the bottom of the tee should be capped to catch soot and debris.

Combustion Air Requirements

In order for the stove to perform efficiently and safely there should be an adequate air supply into the room in which the stove is installed to provide combustion air. This is particularly necessary in modern houses where drafts have been almost eliminated by double glazing etc.

Under UK building regulations any appliance over 5kW MUST have a fixed permanent air vent (see building regulations approved document J for further information).

There must not be an extractor fan fitted in the same room as the stove as this can cause the stove to emit fumes into the room. It is necessary to install a wall vent to provide the necessary combustion air and to prevent the depletion of oxygen in the room.

External Air Intake

It is possible to connect a direct air supply to the stove by attaching a 75mm (3 Inch) diameter rigid or flexible pipe to the air intake shown below (rear of stove at the bottom) using either a jubilee clip or fire cement. Please note that pipe, vents or other ducting accessories are NOT provided.

To use the direct air feature of the product you will need to attach the supplied Air Intake Spigot to the back of the stove.

Attach the Spigot to the rear of the appliance as shown using the supplied fixings (ensure the heat proof gasket is fitted between the spigot and stove back).

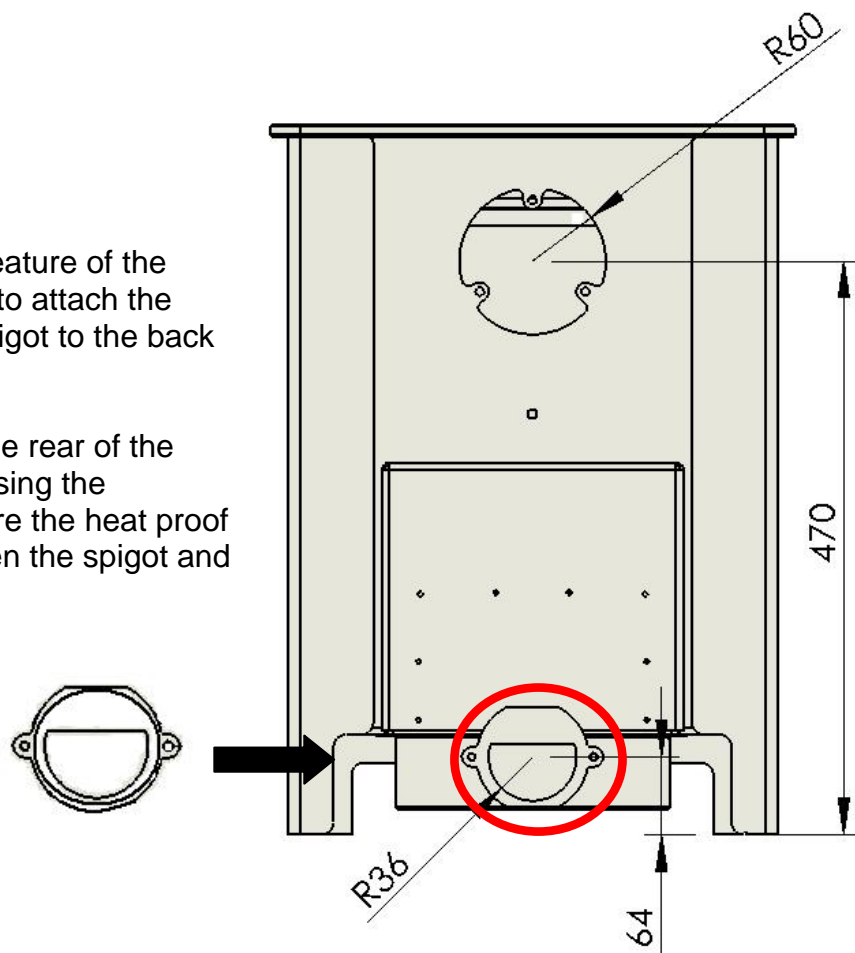

Assembly – Smoke Control Area Modification

Your appliance will require a small modification in the form of a mechanical stop on the secondary (wood) air supply (this ensures that the air intake cannot close beyond the required 10mm minimum position). Your stove will require one of the following changes:

- Smoke Washer installation
- Smoke Stopper Installation

Smoke Washer Installation

PLEASE NOTE THIS MODIFICATION MUST BE MADE PRIOR TO FINAL SITING OF THE PRODUCT AND CHIMNEY CONNECTION.

If your appliance does not have a pre-drilled hole in the Secondary (Wood) air control, then you will need to install the provided smoke washer. Please note for log store versions you will need to do this before installing the stove on the log base.

- 1) Lay the stove on its back ensuring that the stove is supported throughout the maneuver
- 2) Remove the 3 off M6 nuts from the standard washer (keeping them for later use) and remove the washer entirely.
- 3) Place the smoke washer in position as shown and loosely fix into position using the 3 off M6 nuts removed in step two.
- 4) Do not fully tighten the M6 nuts, the nuts will need to be sufficiently slack to allow the sliders to move but not so slack that there is excessive play. Installation is now complete.

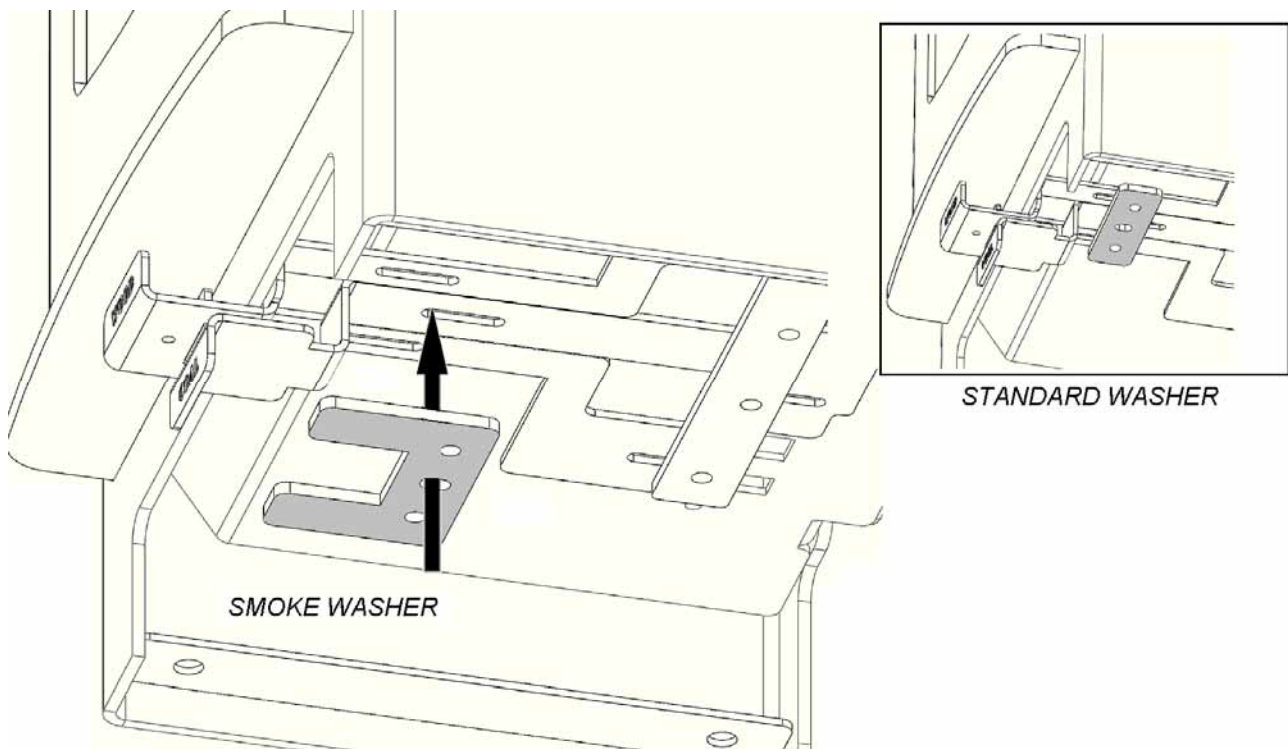

Assembly – Smoke Control Area Modification

Smoke Stopper Installation

If your appliance has the pre-drilled hole in the Secondary (Wood) air control, then you will need to install the provided smoke stopper as follows:

- 1) Pull out the Secondary (Wood) slider from the front of the stove.
- 2) The smoke stopper is fixed through the hole in the slider using the supplied M5 x 6 Button head screw.
- 3) The screw has a socket head fitting, use an allen key to tighten the screw. The Installation is now complete.

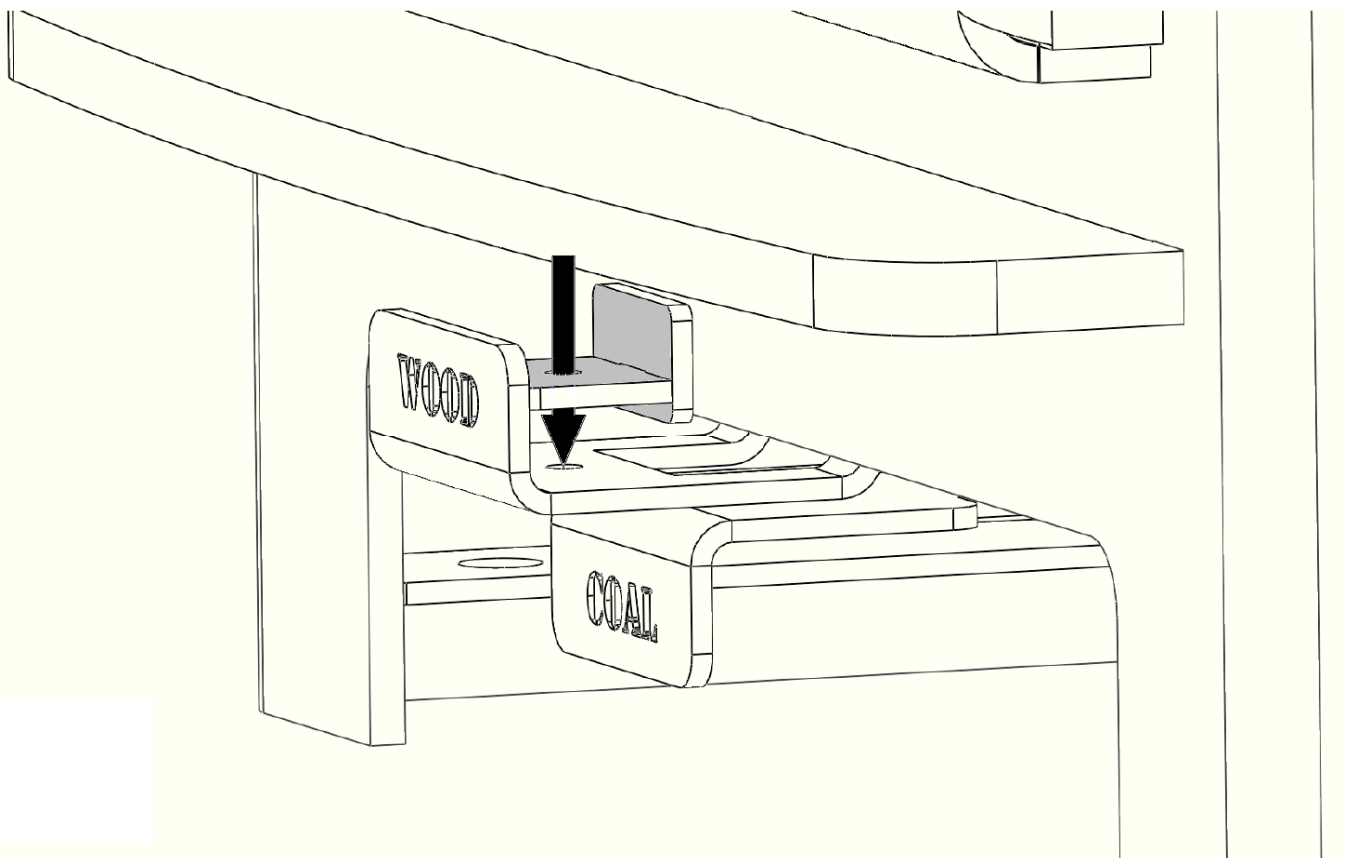

Please note these modifications are only needed on installations located within a designated Smoke Control Area (consult your local council to find out if the property falls within a Smoke Control Area).

Assembly – Log Store

Desire & Ignite Only

It is possible to add (or remove) a log store base to your appliance. The diagram below shows the locations of the fixings (4x bolts labelled 1) which hold the stove to the log store base.

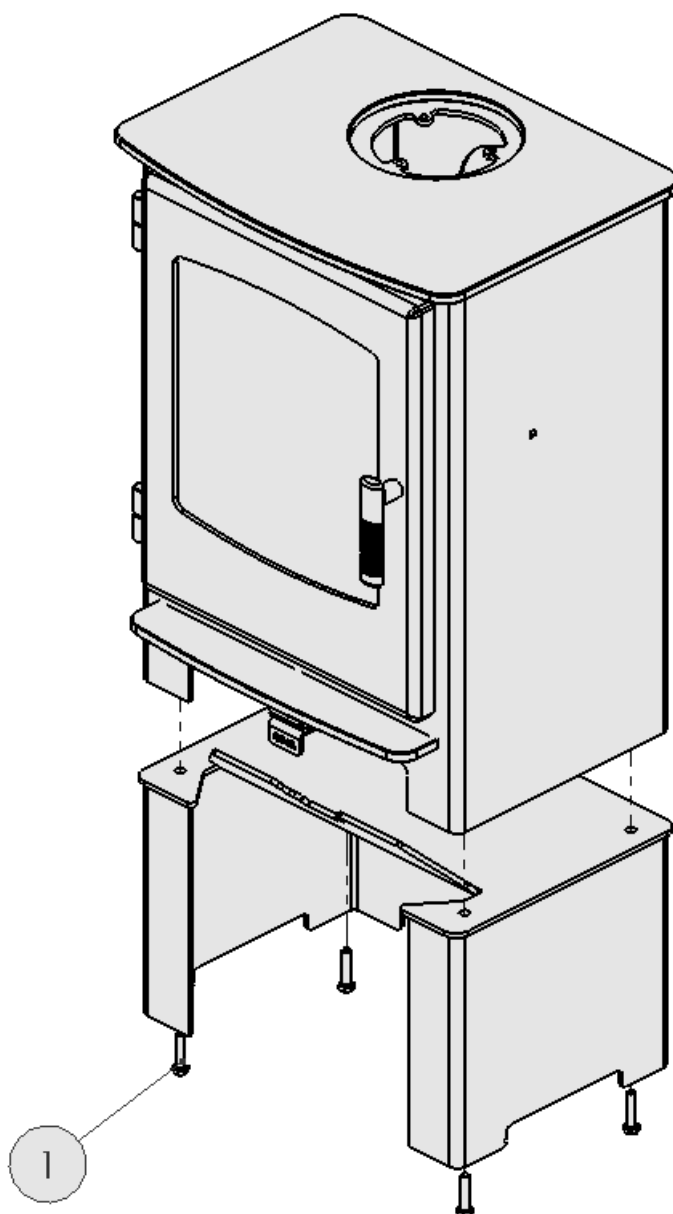

Assembly – Internal Components

The diagram below shows the stove with all internals taken out. To take internals out of the stove follow the numbered sequence backwards from 7 down to 1.

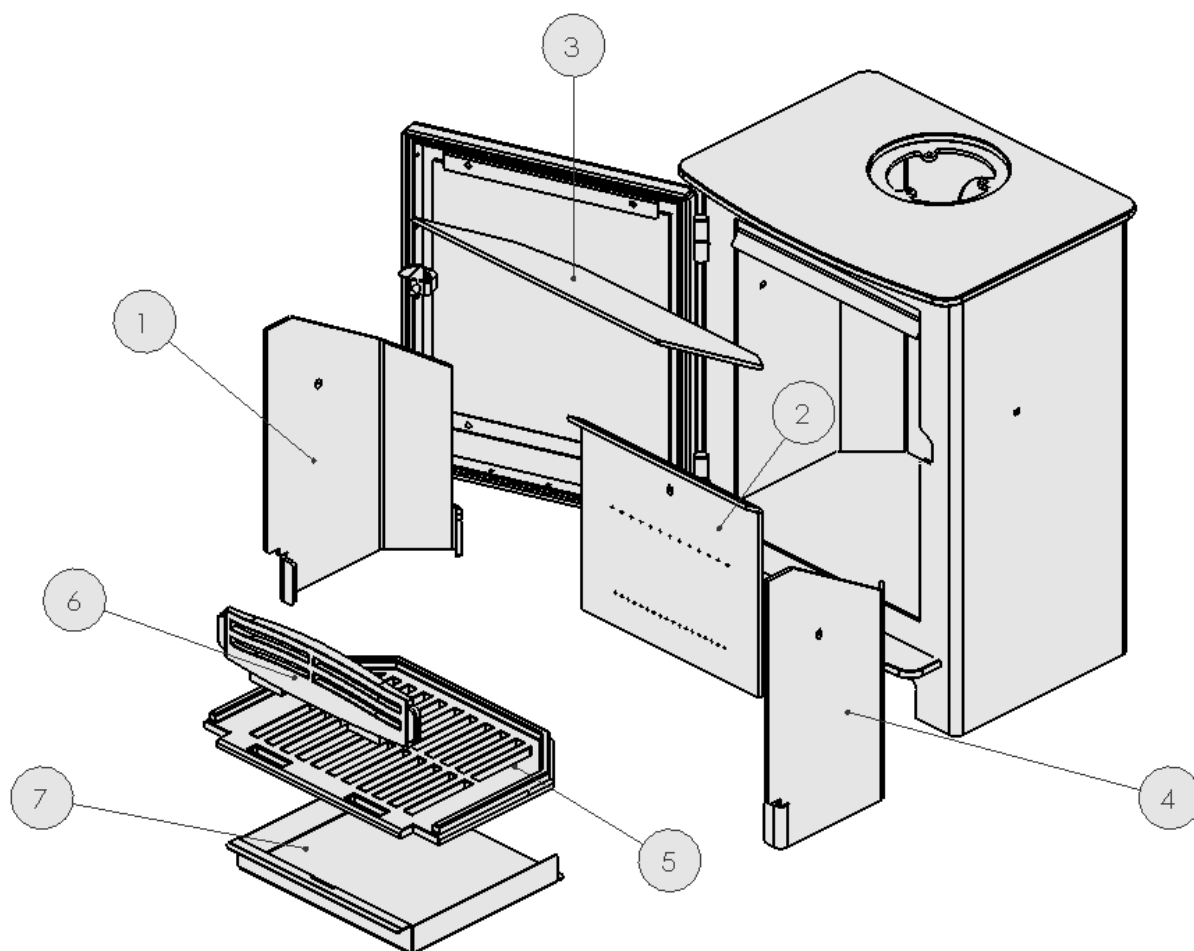

To refit the internals follow the numbered sequence from 1 – 7. The firebricks should be fitted with the fibre paper on the LHS, RHS and rear components, the fibre paper should be sandwiched between the fire brick and the main body, these are then held in position by the retaining screws, small gaps are acceptable between the firebricks. Be careful not to trap or squash fingers at this stage.

Controls Layout

The stove is fitted with two air controls which need to be correctly operated in order to light and maintain a fire. Both controls are situated below the ash lip of the stove (as indicated on the diagram below) and are in the form of push/pull sliders.

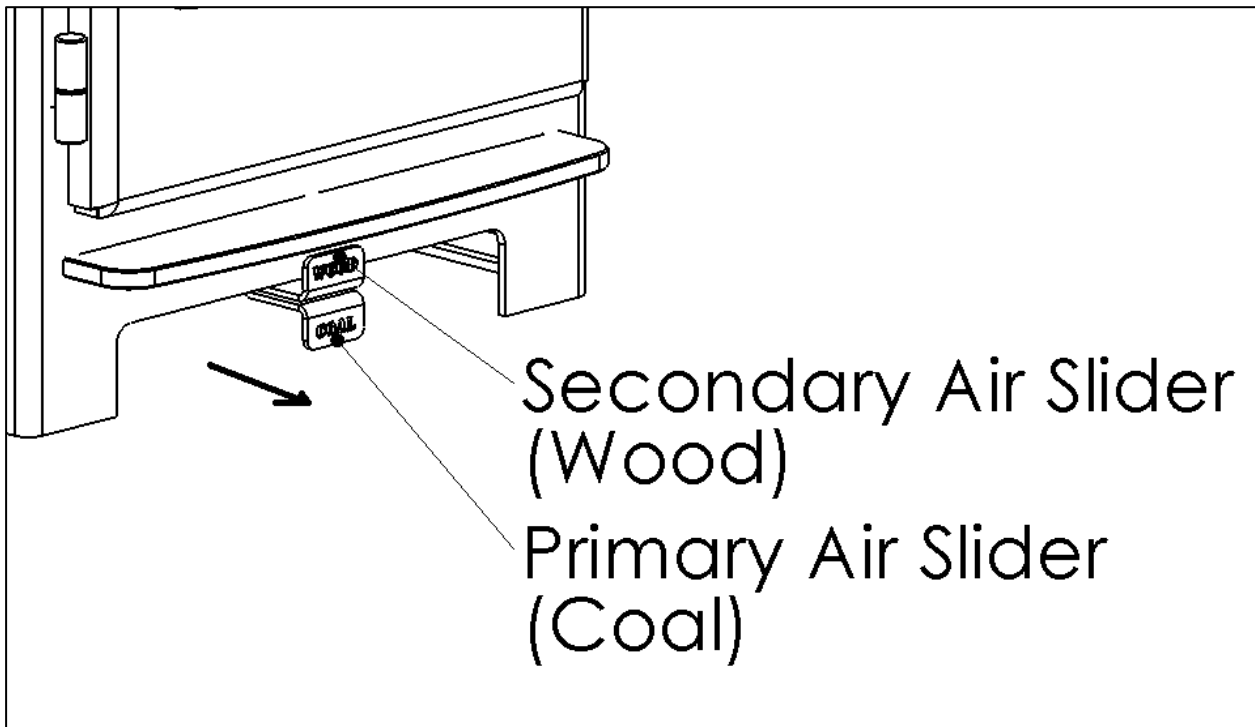

Multi Function Tool

You can use the provided tool to operate both controls (using the flat hook end). For the secondary “Wood” control, simply slide the hook behind the control from either side.

The punted end of the tool located into a hole at the bottom of the handle, this effectively extends the handle which increases leverage for easier operation.



Controls Explained

Primary Air Intake

The primary air intake is the bottom slider situated below the ash lip at the front of the stove. Having the slider pushed fully inwards would indicate the intake is closed. When the slider is fully pulled outwards the intake is completely open. This particular air intake is adjustable throughout the area of travel in to out to control the total amount of air required for suitable combustion.

The primary air intake is used on initial firing of the stove or when burning coal etc. Please see the **BURNING COAL** for a more in depth description.

Secondary Air Intake

The secondary air intake is the top slider situated under the ash lip at the front of the stove. Having the slider pushed fully inwards would indicate the intake is closed. When the slider is fully pulled outwards the intake is completely open. This particular air intake is adjustable throughout the area of travel in to out to control the total amount of air required for suitable combustion.

The Secondary air intake is used at initial start-up and to control the burn rate of wood.

Air wash System

Air wash is a system where secondary air is drawn into the stove (by combustion) through the air control under the ash lip and is deflected down the back face of the glass, thus preventing the smoke coming into contact with the glass. It does not mean that you will never have to clean the glass, but substantially lengthens the periods between having to do so. The air-wash system works best when burning dry wood. Wet wood will produce more deposits on the glass. Also, deposits will form on the back of the glass when the stove is operated on low heat for extended periods (where fuel is only just smouldering).

Ash Pan

The ash pan can be removed using the ash tool which is intended to hook the ash pan out onto the ash lip of the stove where you can then pick it up using the glove provided. It is recommended this is done when the stove is cold and not alight.

Recommended Fuels

This appliance has obtained approval from HETAS Ltd., for burning –

- * HETAS approved coal suitable for a closed appliance.
- * Split Wood logs (not exceeding 350mm in length and 100mm in diameter) not exceeding 20% moisture content.

Approval does not cover the use of other fuels either alone or mixed with the suitable fuels listed above.

Although approval covers the use of the smokeless fuels listed, the claimed rated output, has been obtained burning a single representative smokeless fuel, under standard test conditions. However, in the home, a variety of operating conditions can occur and the performance of the appliance may vary to some degree with these conditions and different fuels may need to be burnt at different rates to provide the same heat output.

The recommended fuels are Wood logs no longer than 35cms (dry, seasoned to under 20% moisture) and solid mineral fuels (e.g. Natural smokeless fuels) Larger coal briquettes are recommended as they concentrate less heat in one spot reducing the likelihood of damage to the grate. Ask your local fuel merchant or consult the HETAS website for more details on these fuels.

Only authorised smokeless fuels may be used in smoke control areas.

Do NOT burn “House coal” or any other coal which are intended for use on open fires. Suitable coal needs to be designed for use on closed appliances. Open fires send a large amount of heat up the chimney therefore the fuel needs to burn extremely hot in order to send heat into the room, closed appliances are highly efficient and send little heat up the chimney therefore the fuel does not need to burn as hot. Using open fire coal on a closed appliance will cause excessive wear on the stove and could result in damage which will not be covered by the products warranty.

Under NO circumstances burn “petroleum coke” or any other chemically enhanced fuel as it will burn out the internal grate and baffle plates in a very short period of time and may damage the stove beyond repair.

Do NOT burn wet wood, This will give a poor heat output and will cause heavy deposits of soot and tar to accumulate on the glass and throughout the stove and flue. The coating of soot and tar in the chimney is volatile creating a high risk of chimney fires. A growing tree contains a high percentage of water, the wood needs to be dried out (seasoned) before it is suitable for burning (this can take several years). Wood logs are best stored in a stack, sheltered from the weather, in a well ventilated area and raised off the ground. This allows the air to circulate and prevents mildew.

Lighting the Stove

Curing

On initial firing you will notice a very pungent odour, this is caused through the curing of the paint, we recommend starting with short burning sessions (with smaller quantities of fuel) and build up gradually to allow the components of the stove to settle. Opening doors and windows will allow the paint curing odour to dissipate and to allow ventilation into the room. Curing times can vary but typically should take around 8-12 hours (operation at high output) to complete. **Please take care not to touch any hot surface of the stove during the curing process as this will result in a permanent mark.**

Kindling

Stage 1

With the Primary and Secondary air controls in the fully open position and the door open, start your fire using scrunched up balls of newspaper. Form a bed on the grate using the newspaper, then add a generous amount of dry kindling in a criss cross pattern (as shown below).



Stage 2

Ignite the paper underneath using a match or suitable fire-lighter. Allow the paper and kindling to burn until it reduces down into hot embers. If the fire is dying during this stage the door can be closed but not latched leaving a small gap for extra combustion air.

Stage 3

Add another generous load of dry kindling and allow to burn down.

It may be necessary to repeat stage 3 if the chimney is cold or if you find you have smoke entering the room. This stage is vital for getting heat into the chimney which will create the draw that takes the smoke away, we would expect this stage to take between 15-20 minutes.

It is critical that you do not leave the stove during the entire lighting and kindling stage. See Burning wood and Burning Coal sections for the next steps in starting a new fire.

Burning Wood

Once you have kindled your stove (see previous page) and your chimney (flue) is sufficiently heated, you are now ready to start adding you logs.

Stage 4

Place 1-3 small logs onto the bed of hot embers using the gloves provided, close the door and reduce the Primary Air Control to approximately half way. Once the logs turn black the primary air can be fully closed.

Stage 5

Once the smaller logs have burned down you can now add 2-3 larger (or full size) logs and close down the Secondary Air Intake as required. You can now control the burn rate of the stove using the secondary air intake, you are looking for a controlled flame (not smouldering in the embers or licking around the lid) this is mostly visual although a flue pipe thermometer will help you determine correct control and is recommended for the initial lightings.

Stage 6

Refuel as and when required (take care to open the door gradually as flames may lick out). Open both air controls whenever refuelling. Once the wood logs turn black the primary control can be closed fully and the fire controlled once again by the secondary control. If you no longer want to keep the fire going simply allow it burn out.

Burning Coal

With kindling complete you are now ready to add your approved coal.

Stage 4

Using the gloves and provided ash tool, rake the hot embers evenly over the grate and add a small amount of coal. Close the door and allow the coal to ignite then close the Secondary Air approximately half way. (The primary air control should be left fully open)

Stage 5

When the small load of coal has burned down add a larger load and allow time for the coal to fully ignite, leave the Primary air intake fully open. The coal should be spread evenly over the grate. You will now control the burn rate of the stove using the Primary air intake. The Secondary air intake should now be fully closed. you are looking for a controlled flame (not smouldering in the embers or licking around the lid) this is mostly visual although a flue pipe thermometer will help you determine correct control and is recommended for the initial lightings.

Stage 6

Add coal as and when required. Ensure that you use the ash tool when refuelling coal to poke through any ash and debris so that it falls into the ash pan underneath, this is critical as coal requires a flow of air from underneath the grate.

Please take care not to touch any hot surface of the stove during the curing process as this will result in a permanent mark.

Smoke Control Areas

The Clean Air Act 1993 and Smoke Control Areas

Under the Clean Air Act local authorities may declare the whole or part of the district of the authority to be a smoke control area. It is an offence to emit smoke from a chimney of a building, from a furnace or from any fixed boiler if located in a designated smoke control area. It is also an offence to acquire an "unauthorised fuel" for use within a smoke control area unless it is used in an "exempt" appliance ("exempted" from the controls which generally apply in the smoke control area).

The Secretary of State for Environment, Food and Rural Affairs has powers under the Act to authorise smokeless fuels or exempt appliances for use in smoke control areas in England. In Scotland and Wales this power rests with Ministers in the devolved administrations for those countries. Separate legislation, the Clean Air (Northern Ireland) Order 1981, applies in Northern Ireland. Therefore it is a requirement that fuels burnt or obtained for use in smoke control areas have been "authorised" in Regulations and that appliances used to burn solid fuel in those areas (other than "authorised" fuels) have been exempted by an Order made and signed by the Secretary of State or Minister in the devolved administrations.

The Ignite & Desire 5, 6 and 7 have all been recommended as suitable for use in smoke control areas when burning wood and fitted with a factory modified secondary/tertiary air control slide to prevent closure beyond the 10mm open position (see Assembly section)

Further information on the requirements of the Clean Air Act can be found here :

<https://www.gov.uk/smoke-control-area-rules>

Your local authority is responsible for implementing the Clean Air Act 1993 including designation and supervision of smoke control areas and you can contact them for details of Clean Air Act requirements

Refuelling on to a low fire bed

If there is insufficient burning material in the firebed to light a new fuel charge, excessive smoke emission can occur. Refuelling must be carried out onto a sufficient quantity of glowing embers and ash that the new fuel charge will ignite in a reasonable period. If there are too few embers in the fire bed, add suitable kindling to prevent excessive smoke

Fuel overloading

The maximum amount of fuel specified in this manual should not be exceeded, overloading can cause excess smoke.

Operation with door left open

Operation with the door open can cause excess smoke. The appliance must not be operated with the appliance door left open except as directed in the instructions.

Dampers left open

Operation with the air controls or dampers open can cause excess smoke. The appliance must not be operated with air controls or dampers door left open except as directed in the instructions

Smoke Control Areas

As mentioned in the Specification and Assembly sections, your stove requires a modification to the air control to make it suitable for smoke control areas. The air intake modification alters the burning outputs of the product when burning Coal/Ancit as follows:

	Ignite, Desire & Hereford 5 (Q5)	Ignite, Desire & Hereford 6 (Q6)	Ignite, Desire & Hereford 7 (Q7)
Nominal Heat Output (Ancit) kW	4.7	6	7.7
Efficiency (Ancit) %	73.4	70.8	73.5
Weight Kg	Ignite 5 71 Ignite 5 LS 85 Desire 5 68 Desire 5 LS 82 Hereford 5 66	Ignite 6 78 Ignite 6 LS 93 Desire 6 74 Desire 6 LS 90	Ignite 7 84 Ignite 7 LS 101 Desire 7 80 Desire 7 LS 97 Hereford 7 77
Flue Diameter mm	125	125	125
Flue Diameter Inches	5	5	5
Flue Draft Min Pa	12	12	12
Flue Draft Max Pa	18	18	18
Flue Temp (Ancit) °C	263	287	315
CO Emission (@ 13% O ² Ancit) %	0.52	0.52	0.35
Flue Mass Flow (Ancit) g/s	5.1	7.5	7.5
Fuel Consumption Per Hour (Ancit)	0.7 Kg	0.9 Kg	1.1 Kg

Warning Notes

Over-Firing

It is extremely important that you do NOT leave both of the air controls in the fully open position for extended periods or run the appliance with the door open. Leaving the air controls fully open (or running with the doors open) will lead to “over-firing”. Over-firing is caused when too much heat is generated within the fire chamber, this will lead to warping, buckling and general damage to the stove and its internal components. Over-firing can also be caused by an excessive flue draft.

PLEASE NOTE ANY DAMAGE TO THE APPLIANCE CAUSED THROUGH OVER-FIRING WILL NOT BE COVERED BY THE WARRANTY.

We highly recommend the use of a flue pipe thermometer so that you can monitor how much heat you are sending up the chimney, this will both enable efficient operation of your stove and also give a good indication if you are over-firing the appliance.

Fumes

Properly installed, operated and maintained, this appliance will not emit fumes into the dwelling. Occasional fumes may occur whilst de-ashing and re-fuelling. However, persistent fume emission is potentially dangerous and must not be tolerated. If fume emission does persist, the following immediate actions should be taken:-

- a. Open doors and windows to ventilate the room
- b. Let the fire go out or eject and safely dispose of fuel from the appliance
- c. Check for flue or chimney blockage and clean if required
- d. Do not attempt to relight the fire until the cause of the fume emission has been identified and corrected. If necessary seek expert advice

Paint

Please take care not to touch any hot surface of the stove during the curing process as this will result in a permanent mark.

Extended Shutdown

If the stove is to be left unused for a prolonged period of time then it should be given a thorough clean to remove ash and unburned fuel residues. To enable a good flow of air through the appliance to reduce condensation and subsequent damage, leave the air controls fully open.

It is important that the flue connection, any appliance baffles or throat plates and the chimney are swept prior to lighting up after a prolonged shutdown period.

Maintenance

Door adjustment (Desire & Ignite Only)

In the case of the door rope not providing an adequate seal to the room, products of combustion may enter the room (see warning notes), to ensure an adequate seal the door may need to be periodically adjusted as the rope seal wears with use.

Hinge Adjustment (seal on Left hand side is not compressed):

- Ensure that the stove is cold before proceeding
- Remove the door by lifting the door off the hinges
- Loosen the Hinge Locking nut inside the stove
- Rotate the hinge by 1 turn (clockwise to tighten seal, anticlockwise to loosen seal) on both the top and bottom hinge, this ensures that the door seal will compress or loosen evenly
- Re fit the door back onto the hinges and tighten the locking nut inside the stove
- Check the seal provides an adequate seal.

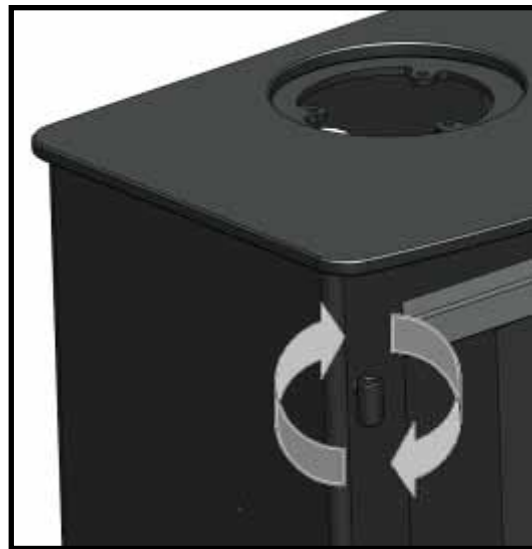

Door Latch adjustment (seal on Right hand side is not compressed):

- Ensure that the stove is cold before proceeding
- Adjustment can be made with the door on the stove
- Slacken Locking nut 1
- Adjust Locking nut 2 to required depth
- Re tighten locking nut 1 to complete adjustment
- Check the seal provides an adequate seal
- Locking Nut 3 is factory set to the correct handle shaft depth, this Locking nut should only be adjusted to take up slack in the handle and not for door seal adjustment.

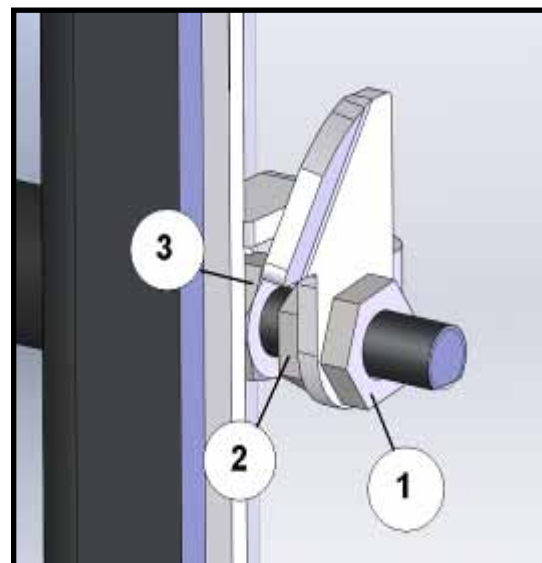

Maintenance

Ash Removal

The ash pans can be removed by using the ash tool to hook it forward so that you can grasp the pan using the gloves provided. We would recommend emptying the ash into a metal bucket for transportation.

You should only empty the ash when the appliance and ashes are completely cool and can be disposed of in your normal household refuse.

Cleaning the Stove

We recommend only doing this when the stove is cold using a soft brush to clean any of the stove surfaces, this is normally sufficient to remove dust, ash and debris. For stubborn marks you can use a damp lint free cloth, ensure that all surfaces are dried off immediately. We do not recommend using any kind of chemicals or abrasive materials. It is possible to touch up the paint using the original metallic black stove paint, however this new paint will then need to cure.

Glass Cleaning

A damp lint free cloth is normally sufficient, however for stubborn build ups we would recommend using a very fine wire wool.

Chimney Sweeping

It is essential that your chimney (flue) is swept at least once a year by a registered professional chimney sweep. Sweeping removes particles that could otherwise fuel a chimney fire, it should also highlight any potential issues such as leaks and damage to the flue.

Chimney Fires

In the event of a chimney fire ensure both Primary and Secondary air controls are fully closed and the door(s) remain closed at all times. If the chimney fire does not go out or if there is a serious risk to people and property, call the fire brigade immediately.

Regular sweeping of the chimney will remove combustible particles and will reduce the risk of chimney fires.

Stove Servicing

Your stove should be inspected annually to ensure all seals are present and correct and to gauge the condition of the internal components. The service should be done by a HETAS registered engineer who also perform a spillage test and ascertain the correct functioning of the plumbing circuit.

Trouble-shooting

Smoke comes out of the stove when the loading door is opened.

- The chimney cavity into which the 150mm flue pipe has been installed may be less than the minimum requirement.
- Deposits (soot or other obstructions) may have built up in the chimney and be restricting the flow of waste products. This flow rate is known as the 'draw'.
- Insufficient draw, this is especially common during milder weather. You will need to prolong the kindling stage to ensure the chimney (flue) is completely hot (you may even need to pre-heat the chimney using a method advised by the installer)
- Combustion air intake is not large enough or another appliance (e.g. Extractor fan) is taking air away from the stove.

The Stove does not produce the expected heat into the room.

- Has the flue pipe been sealed to the chimney to prevent heat being drawn up the chimney to waste?
- Green or wet wood is being burnt.
- The chimney has excessive draw (this is unusual). Seek installer advice with regard to installing a Flue Draught Stabiliser.
- The stove has been recessed into the existing fireplace and a lot of heat is being absorbed by the surrounding fireplace walls rather than being radiated into the room. Pull the stove forward.
- For the maximum efficiency of heat transference into the room the stove should be sited on the hearth of the fireplace rather than recessed.

The Stove burns too fast.

- Use whole logs rather than split ones.
- The wood being used may be generally too small.
- The "air-tight" seal between the fibre rope on the doors and the casting may have been lost, adjust door handle lock nuts or hinges to reinstate this seal or replace.
- The chimney has excessive draw (seek installers advice on this point).
- The fibre rope seal between the door and the glass may be leaking. Tighten or replace.
- The fibre rope on doors and glass has worn out. Replace.

The Stove door does not seal properly.

- Adjust the door hinges (maintenance section) to ensure a good seal on the left hand side of the door.
- Adjust the door latch (maintenance section) to ensure a good seal on the right hand side of the door.
- Replace door seal if the above does not provide an adequate seal.

Commissioning Form

Commissioning Statement and Check-list

Stove Purchased

From: _____

Address: _____

Telephone Inc area code: _____

Installation Date: ____/____/____ Stove Name: _____

1st year service is due 1 year from this date

Product Serial Number: _____ Invoice Number: _____

Stove installed by: _____

Address: _____

Telephone Inc area code: _____

HETAS Registration Number: _____

Check-list (please indicate Yes or No by circling or ticking appropriately)

Is the flue system the correct length and diameter for stove:	Yes	No
Flue swept and checked for soundness:	Yes	No
Manufacturers clearances adhered:	Yes	No
Smoke spillage test performed on stove:	Yes	No
Stove controls fully explained to end user:	Yes	No
Correct fuels explained to end customer:	Yes	No
CO Alarm fitted and tested:	Yes	No
Instruction booklet & HETAS certificate handed to end user:	Yes	No

Signature: _____ Print Name: _____

Spare Parts

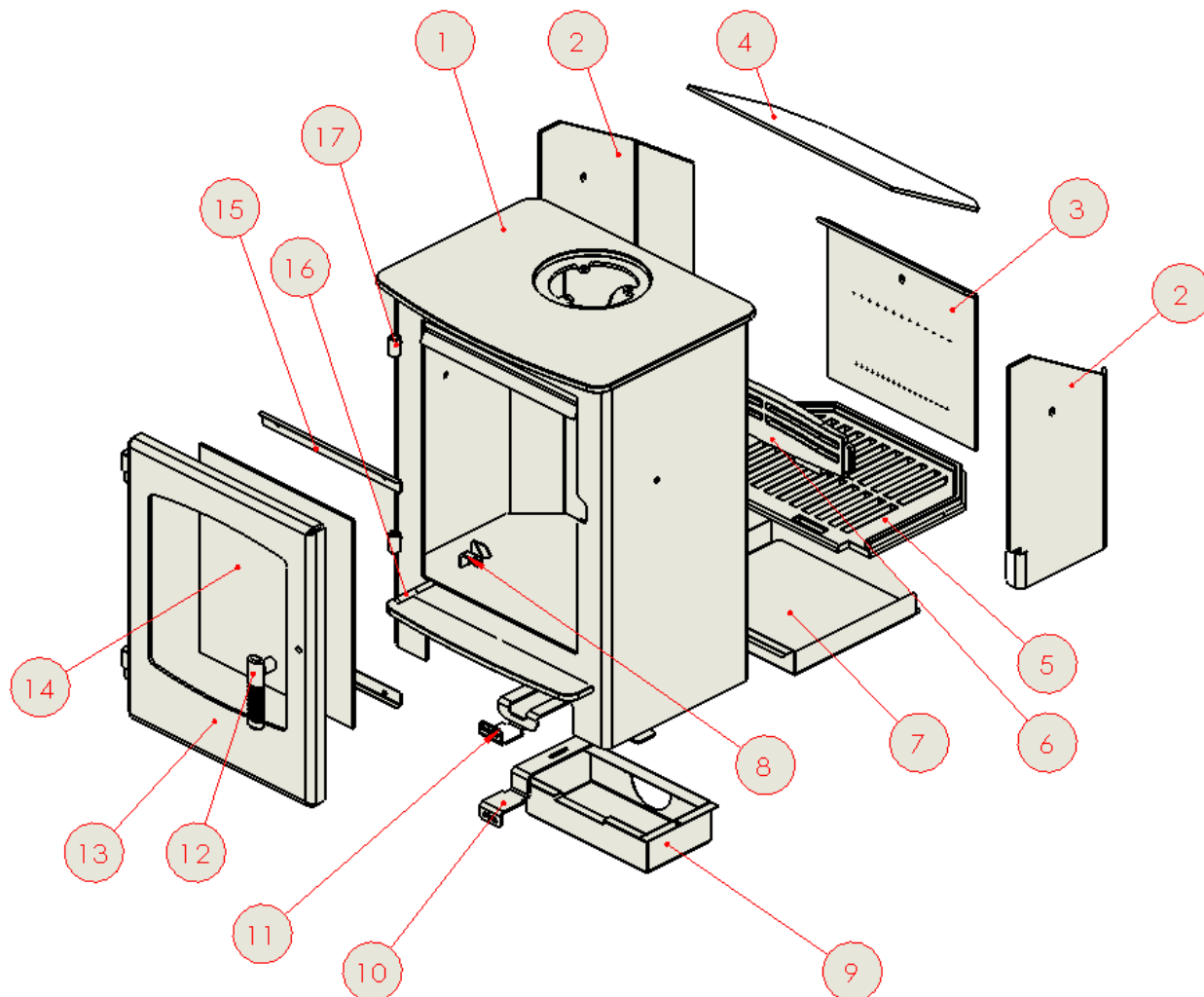

Steel Door Version

1: Stove Engine. 2: LHS and RHS baffle plate set, 3: Rear Baffle, 4: Top Baffle, 5: Cast Grate, 6: Cast grate front, 7: Ash pan, 8: Latch, 9: Air box, 10: Coal Slider
 11: Wood Slider, 12: Door Handle, 13: Steel Door, 14: Glass, 15: Steel door Glass retaining bar (x2), 16: Steel door Latch shaft, 17: Steel Door Hinge

Annual Service Record

1ST YEAR SERVICE completion date:

SERVICE ENGINEER: _____ REG. No. _____
COMPANY NAME: . _____
COMPANY ADDRESS: . _____

CONTACT NUMBER _____ POSTCODE: _____

2ND YEAR SERVICE completion date:

SERVICE ENGINEER: _____ REG. No. _____
COMPANY NAME: . _____
COMPANY ADDRESS: . _____

CONTACT NUMBER _____ POSTCODE: _____

3RD YEAR SERVICE completion date:

SERVICE ENGINEER: _____ REG. No. _____
COMPANY NAME: . _____
COMPANY ADDRESS: . _____

CONTACT NUMBER _____ POSTCODE: _____

4TH YEAR SERVICE completion date:

SERVICE ENGINEER: _____ REG. No. _____
COMPANY NAME: . _____
COMPANY ADDRESS: . _____

CONTACT NUMBER _____ POSTCODE: _____

5TH YEAR SERVICE completion date:

SERVICE ENGINEER: _____ REG. No. _____
COMPANY NAME: . _____
COMPANY ADDRESS: . _____

CONTACT NUMBER _____ POSTCODE: _____

6TH YEAR SERVICE completion date:

SERVICE ENGINEER: _____ REG. No. _____
COMPANY NAME: . _____
COMPANY ADDRESS: . _____

CONTACT NUMBER _____ POSTCODE: _____

Receipts should be retained for each service beyond year six.

Warranty

This appliance must be installed and commissioned by a fully qualified, registered engineer. A "Declaration of completion Certificate" must be obtained for the installation and retained by the end user. Failure to comply with these requirements may void your warranty. You, as the end user, have a contract by law with the supplier / dealer from whom you purchased the product. That dealer then has the same contract with the manufacturer or wholesaler and these have a contract with their suppliers.

ALL CLAIMS MUST FOLLOW THIS PROCEDURE.

Thank you for choosing a Product from **Broseley Fires Ltd**. This warranty gives you specific legal rights. The statutory rights of the consumer are not affected by the warranty, or the consumers' rights against the dealer arising from their sales / purchase contract.

The manufacturers' warranty:

Your Product will be free from defective parts, material, and workmanship at the time of its original purchase for a period of Five (5) years. This Warranty will become active as of one month from the date of delivery.

This warranty does not cover any failure of the unit due to normal wear and tear, misuse, abuse, accident, illegal modification, illegal installation or repair, damage resulting from improper use or failure to maintain the product. Variations in color and texture are a natural characteristic of heating products. Colour changes may result from exposure to light and other elements which are a part of the aging process. These material variations and changes are not covered by this warranty. If during the warranty period, this Product fails to operate under normal use and service, due to defects in material and / or workmanship, Broseley Fires will either repair or replace the product. The repaired or replaced product shall be warranted for the remaining period of the original warranty + the time taken to days from the date of repair, whichever is longer.

Repair or replacement may involve the use of functionally equivalent reconditioned units. Replaced parts or components will become the property of Broseley Fires.

Should you wish to claim under the warranty, please contact the supplier / dealer from whom you purchased the appliance. Do not claim directly to Broseley Fires, as they are unable to process any direct claim from an end user.

Product design and any specifications are subject to change without notice. This is due to our continuous product development and improvement. The buyer will not be entitled to request free upgrades to the new design or compensation for previously purchased products or any products on order.

- This Warranty covers all Broseley Fires costs within the Warranty period.

If the appliance remains uninstalled for a period greater than six months from date of delivery the Warranty will become active six months from the date of original invoice to the distributor.

IN NO EVENT SHALL BROSELEY FIRES BE LIABLE FOR INCIDENTAL OR CONCEQUENTIAL DAMAGES OF ANY NATURE WHATSOEVER, INCLUDING BUT NOT LIMITED TO LOST PROFITS OR COMMERCIAL LOSS, TO THE FULL EXTENT THOSE DAMAGES CAN BE DISCLAIMED BY LAW. (if applicable)

NON - COVERAGE OF THE GUARANTEE

The consumable items within the product are not covered by the warranty, nor is the glass. If the end-user's claim should not be covered by this guarantee, the end-user shall be liable for costs incurred by Broseley Fires such as callout and inspection costs for examination of the product, transportation costs of the product as well as any other relevant costs. If, after having been informed about the non-coverage of the guarantee, the end-user wants to have the repairs done, the end-user shall additionally pay for any spare parts used and for the labour and transportation costs incurred. If repairs are carried out under this guarantee, the remaining guarantee period for the product shall be extended by the period of time that has elapsed since the complaint was officially logged with Broseley Fires until the repairs have been completed.

A COPY OF OUR FULL TERMS AND CONDITIONS IS AVAILABLE ON REQUEST.

** End-user means the natural or legal person who owns the product and who has not acquired it with a view to reselling or installing it in the course of business