

Contact Details

Please note that some of the contact details on this PDF document may not be current.

Please use the following details if you need to contact us:

Telephone: 0844 879 3588

Email: customer.services@gdcgroup.co.uk

The customer support section of our website also features a wide range of information which may be of use to you and is available 24 hours a day. It includes:

- Operating and installation instructions
- Easy 'How to use' guides for storage heaters
- Service and repairs
- Where to buy our products
- Literature downloads
- Heating requirement calculator

Visit - www.dimplex.co.uk/support

Dimplex



Piermont PMN20

08/50928/0 Issue 1

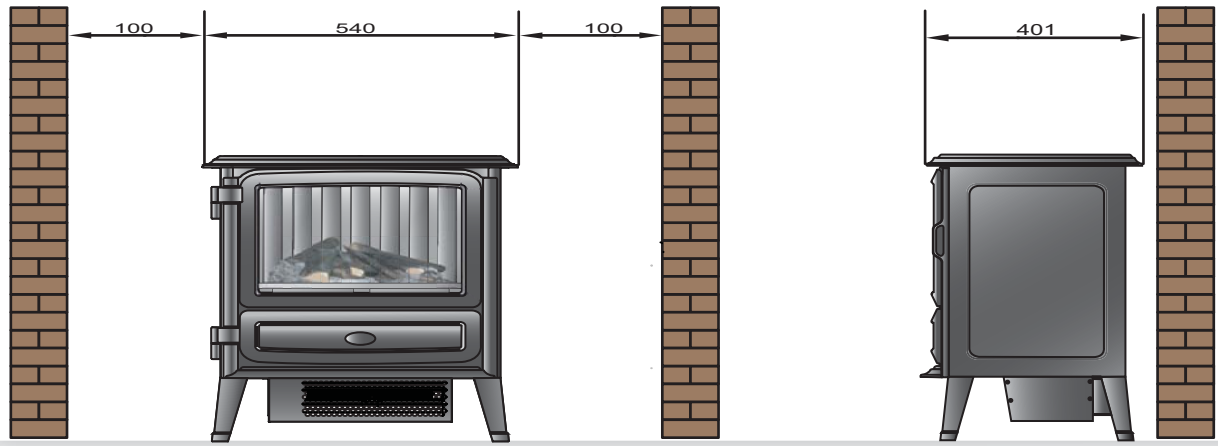

Fig.1

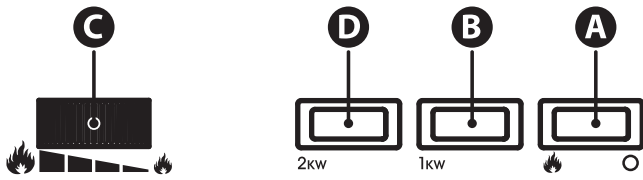

Fig.2



Fig.3

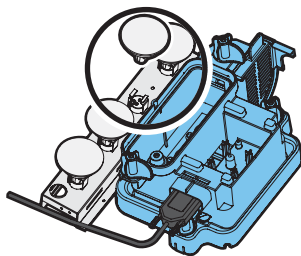

Fig.4

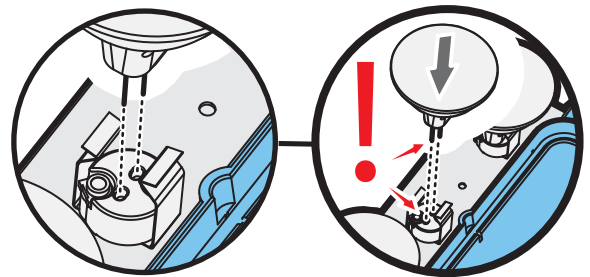

Fig.5

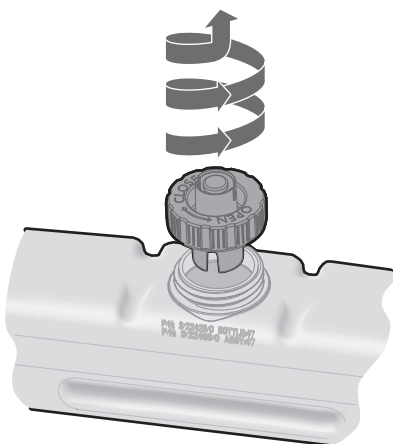

Fig.6

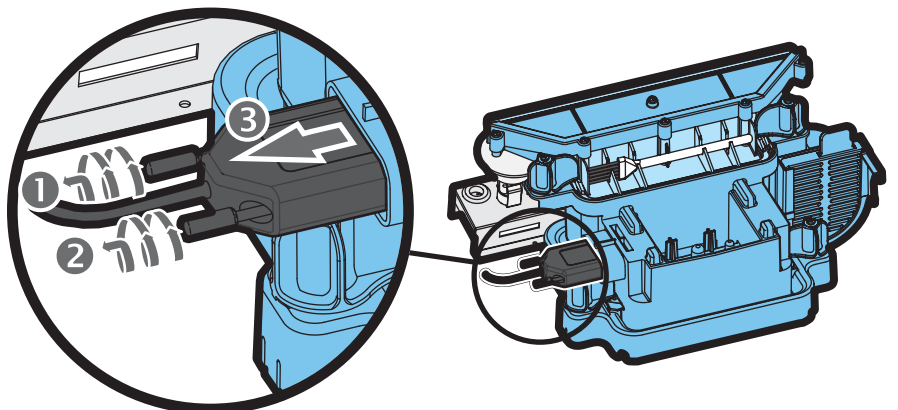

Fig.7

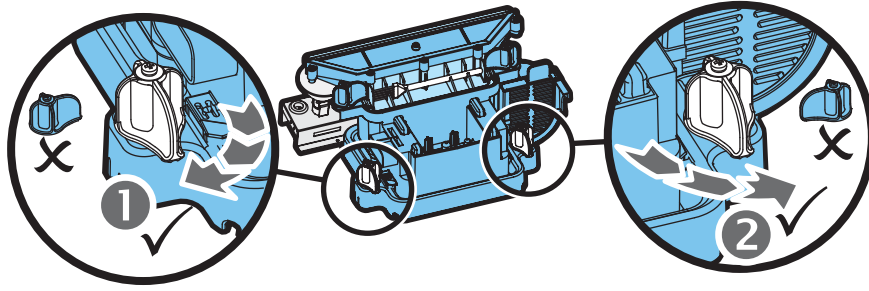

Fig.8

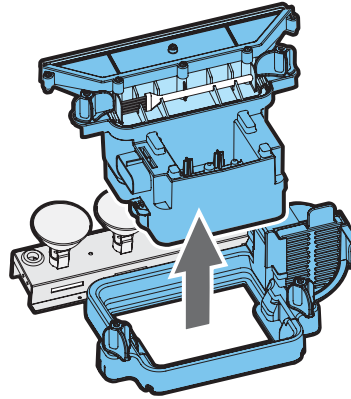

Fig.9

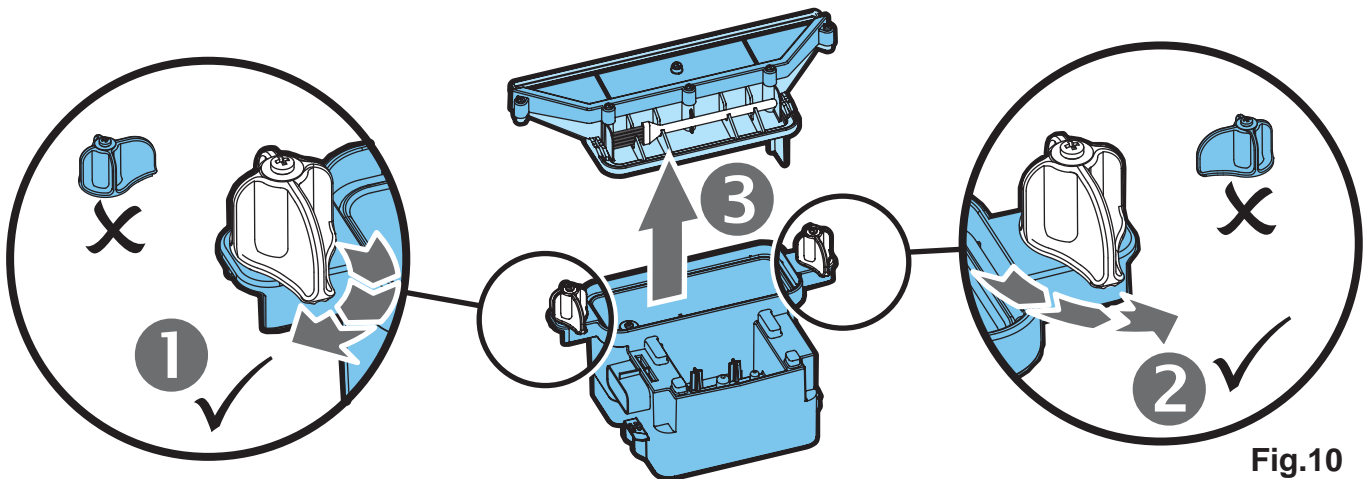

Fig.10

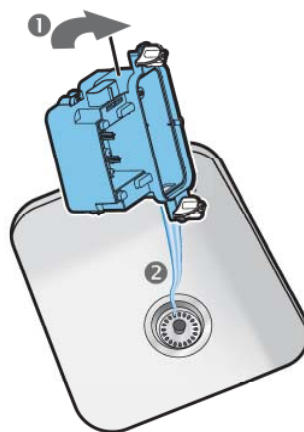

Fig.11

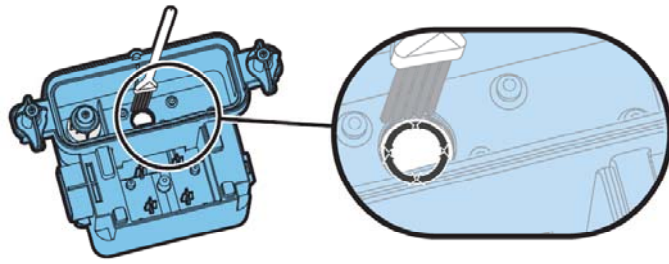

Fig.12

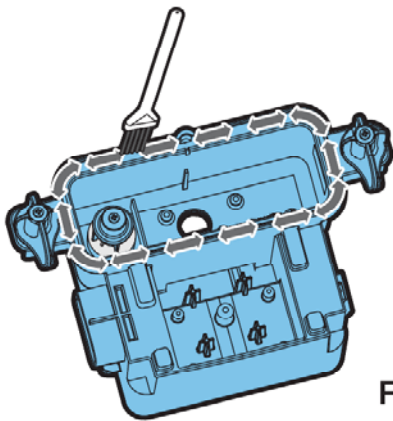

Fig.13

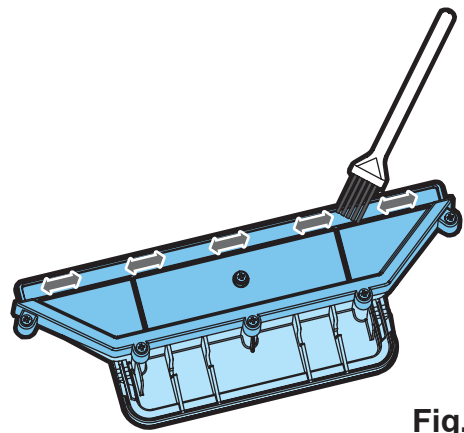

Fig.14

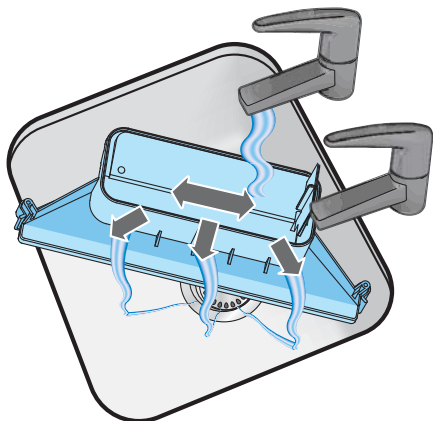

Fig.15

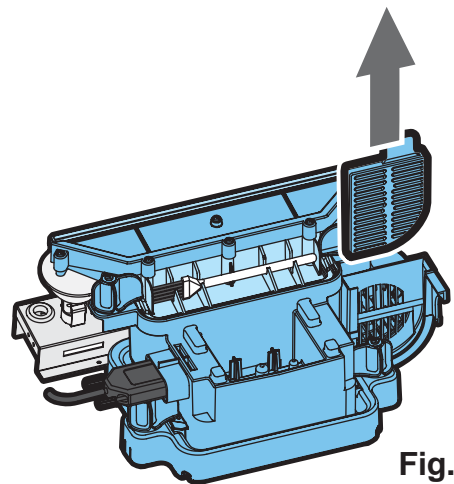

Fig.16

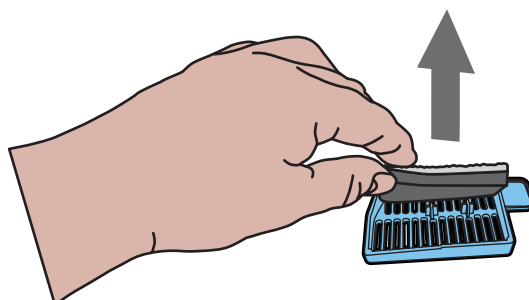

Fig.17

Dimplex Opti-myst Stove

Model: Piermont PMN20

IMPORTANT: THESE INSTRUCTIONS SHOULD BE READ CAREFULLY AND RETAINED FOR FUTURE REFERENCE

Important Safety Advice:

When using electrical appliances, basic precautions should always be followed to reduce the risk of fire, electrical shock and injury to persons, including the following: If the appliance is damaged, check with the supplier before installation and operation. Do not use outdoors.

Do not use in the immediate surroundings of a bath, shower or swimming pool. Do not locate the heater immediately below a fixed socket outlet or connection box. This appliance is not intended for use by children or other persons without assistance or supervision if their physical, sensory or mental capabilities prevent them from using it safely. Children should be supervised to ensure that they do not play with the appliance.

Do not use this heater in series with a thermal control, a program controller, a timer or any other device that switches on the heat automatically, since a fire risk exists when the heater is accidentally covered or displaced.

Ensure that furniture, curtains or other combustible material are positioned no closer than 1 metre from the heater.

In the event of a fault unplug the heater.

Unplug the heater when not required for long periods.

Although this heater complies with safety standards, we do not recommend its use on deep pile carpets or on long hair type of rugs.

The appliance must be positioned so that the plug is accessible.

If the supply cord is damaged it must be replaced by the manufacturer or service agent or a similarly qualified person in order to avoid a hazard.

Keep the supply cord away from the front of the heater.

WARNING: In order to avoid a hazard due to inadvertent resetting of the thermal cut-out, this appliance must not be supplied through an external switching device, such as a timer, or connected to a circuit that is regularly switched on and off by the utility.

WARNING: In order to avoid overheating, do not cover the heater. Do not place material or garments on the heater, or obstruct the air circulation around the heater.

The heater carries a DO NOT COVER warning indicating that the it must not be covered

General.

Unpack the stove carefully and retain the packaging for possible future use, in the event of moving or returning the stove to your supplier. The stove incorporates a flame effect, which can be used with or without heating, so that the comforting effect may be enjoyed at any time of the year. Using the flame effect on its own only requires little electricity.

These models are designed to be free standing and are normally positioned near a wall.

Before connecting the stove check that the supply voltage is the same as that stated on the heater.

Please note: Used in an environment where background noise is very low, it may be possible to hear a sound which is related to the operation of the flame effect. This is normal and should not be a cause for concern.

If this product experiences a power surge for whatever reason the product may cut-out. This is a normal safety feature and the product will resume operation after 30 seconds.

Electrical connection.

WARNING – THIS APPLIANCE MUST BE EARTHED.

This stove must be used on an AC – supply only and the voltage marked on the heater must correspond to the supply voltage.

Before switching on, please read the safety warnings and operating instructions.

PLEASE RETAIN THIS USER'S GUIDE FOR FUTURE REFERENCE

Do not put Opti-myst plastic components into a dishwasher.

Only slide out the drawer when the water tank needs to be filled or a lamp needs to be changed otherwise you will inadvertently alter the water level and the flame effect operation.

Only use filtered tap water in this appliance.

Always ensure that the appliance is sitting on a level floor.

If you intend not using the appliance for longer than 2 weeks, drain the water from sump and water tank and dry the sump.

Once installed, never move this stove or lay on its back, without draining the water from sump and water tank.

The water tank, sump, sump lid, tank cap and air filters must be cleaned once every two weeks, particularly in hard water areas.

The appliance should never be operated if the lamps are not working.

The lamps should be regularly inspected as described under '[Maintenance](#)' and '[Fitting Replacement Lamps](#)'.

Installation Instructions

Ensure that all packing items are removed (read any warning labels carefully).

Retain all packing for possible future use, in the event of moving or returning the appliance to your supplier.

To reduce heat losses and to prevent any chimney updraught affecting the operation of your fire we recommend that the chimney flue is blocked off, ensuring that there is a slight gap for ventilation.

To install the appliance;

Place the stove against a wall and connect the stove to your electricity supply.

Plug the stove into a 13amp/240volt outlet.

Before switching on the appliance, please read the following instructions.

Before using the product firstly fill the water tank (See '[Maintenance](#)', '[Filling the water tank](#)').

Manual Controls.

The stove Manual controls are located behind the door.

(See Fig.2 for Manual Control lay out)

Switch 'A':- Controls the electricity supply to the heater.

Note: This switch must be in the 'ON' (🔥) position for the heater to operate with or without heat. This will be indicated by one beep. Although the main lights operate immediately it will take a further 30 seconds before the flame and smoke effect starts.

Switch 'B':- **Press 1kw to turn on half heat.**

Switch 'D':- **Press 2kw to turn on full heat.**

Control Knob 'C':- Controls the intensity of the flame and smoke effect.

Turning the control knob to the left increases the flame effect, turning the control knob to the right will decrease the flame effect.

When the water tank is empty the main lamps go out. See instructions under '[Maintenance](#)', '[Filling the water tank](#)'. When this procedure is complete, the main lamps will illuminate but it will take 30 seconds before the flames return.

Depending on room temperature and humidity upon initial start up there may be some condensation on the inside of the stove. This can be overcome by turning the flame control knob down and leaving the door of the stove slightly ajar, until the glass warms up.

Thermal safety cut-out

A thermal safety cut-out is incorporated in the fan heater to prevent damage due to overheating. This can happen if the heat outlet was restricted in any way. If the cut-out operates, unplug the heater from the socket outlet and allow approximately 10 minutes before reconnecting. Before switching the heater back on remove any obstruction that may be restricting the heat outlet, then continue normal operation.

Tips for using your appliance.

1. Only pull out the drawer when it's time to refill the water tank or change a lamp, otherwise it may lead to excess water in the sump and reduced flame effect. If this happens empty the water from the sump as instructed under '[Maintenance](#)'.

2. With the flame setting on minimum the unit will use approximately 40ml of water per hour and will last 3 times as long than when it is at maximum flame setting.

3. Do not tilt or move the stove while there is water in the tank or sump.

4. Make sure that the stove is on a level floor.

5. The flame control knob 'C' Fig.2 may be turned up or down to give a more realistic effect. Do not assume that the setting should be on maximum because sometimes the flames and smoke effect appear more real when the flame control knob is turned down.

6. Give the flame and smoke generator some time to react to changes you may make on the flame control knob.

7. If condensation occurs on the inside surfaces, reduce the amount of smoke and flames produced and leave the door slightly ajar.

Maintenance

WARNING: ALWAYS DISCONNECT FROM THE POWER SUPPLY BEFORE ATTEMPTING ANY MAINTENANCE

Fitting Replacement Lamps.

If a large amount of the smoke appears grey or colourless it may be that one or more lamps have failed.

You can check for lamp failure as follows.

1. Leaving the flame effect on, open the door fully and gently pull the drawer fully out. (See Fig.3)

2. View the lamps from a distance in front of the stove and observe which lamp needs to be changed.

3. Put Switch 'A' in the 'OFF' (0) position, and unplug the stove from the mains.

4. Leave the appliance for 20 minutes to allow the lamps to cool down before removing them.

5. Remove the water tank by lifting upwards and place in a sink.

6. Remove the sump as described in the Cleaning Section.

7. Remove the defective lamp, by gently lifting vertically and disengaging the pins from the lamp holder, (See Fig.4 and 5). Replace with a Dimplex Opti-myst, 12V, 50W, Gu5.3 base, 8° beam angle, coloured lamp. (Purchased from www.dimplex.co.uk under the section 'After Sales Service', details of how to purchase the lamps are contained therein.)

8. Carefully insert the two pins of the new lamp into the two holes in the lamp holder. Push firmly in place. (See Fig.4 and 5).

9. Replace the Sump and water tank and carefully close the drawer and door.

10. Switch on.

Filling the water tank.

When the water tank is empty, flame and smoke effect shuts off, and you will hear 2 audible 'beeps'. Follow these steps to refill:

1. Fully open door.

2. Press Switch 'A' to the 'OFF' (0) position (See Fig.2).

3. Gently pull out the drawer as far as possible. (See Fig.3)

4. Remove the water tank by lifting upwards and outwards.

5. Place the water tank in sink and remove cap anti-clockwise to open. (See Fig.6)

6. Fill tank with **filtered tap water only**. This is necessary to prolong the life of the flame and smoke producing unit.

The water should be filtered through a conventional domestic water filter unit and the filter should be replaced regularly.

7. Screw the cap back on, **do not overtighten**.

8. Return the tank to the sump, with the tank cap facing down and the flat side of the tank facing outward.

9. Gently push the drawer back in as far as it will go.

10. Press Switch 'A' to 'ON' (🔥) position (See Fig.2)

WARNING: ALWAYS DISCONNECT FROM THE POWER SUPPLY BEFORE ATTEMPTING ANY MAINTENANCE

Cleaning

We recommend cleaning the following components once every 2 weeks, particularly in hard water areas:-
Water Tank, Sump and Seal, Sump lid, Tank cap and seal, Air filter.

For general cleaning use a soft clean duster – never use abrasive cleaners. To remove any accumulation of dust or fluff the soft brush attachment of a vacuum cleaner should occasionally be used to clean the outlet grille of the fan heater.

Water tank

1. Remove water tank, as described earlier, put into sink and empty water.
2. Using the supplied brush gently rub the inside surfaces of the cap paying particular attention to the rubber ring in the outer groove and the centre rubber seal.
3. Put a small quantity of washing up liquid into the tank, refit the cap and shake well, rinse out until all traces of washing up liquid are gone.
4. Refill with filtered tap water only, replace the cap, do not overtighten.

Sump

In order to remove the sump:

1. Fully open the door and press Switch 'A' to the 'OFF' (0) position.
2. Gently pull the drawer out as far as possible. (See Fig.3)
3. Remove the water tank by lifting upwards.
4. Disconnect the electrical connector, located on the left side of the sump, by first loosening the two retaining screws and gently withdrawing the connector. (See Fig.7)
5. Release the lower sump locking tabs by turning 90°, this allows the sump to be lifted completely from its location. (See Fig.8)
6. Gently lift up the sump assembly, taking care to keep level so not to spill any water. Sit the assembly in the sink. (See Fig.9)
7. Release the two upper sump locking tabs by turning 90°, then lift off the sump lid. (See Fig.10)
8. Carefully tilt, as shown, so that the liquid drains out of the sump. (See Fig.11)
9. Put a small amount of washing up liquid into the sump, and using the supplied brush, gently clean all surfaces including the metal discs and the rubber seal located in the top grooved surface. **Do not remove the rubber seals.** (See Fig.12 and 13)
10. When cleaned, thoroughly rinse the sump with clean water.
11. Clean the outlet surface of the sump lid with the brush and flush out thoroughly with water. (See Fig.14 & 15)
12. Reverse the above steps to reassemble.

Air filter.

1. Fully open the door and press Switch 'A' to the 'OFF' (0) position (See Fig.2)
2. Gently pull the drawer out as far as possible. (See Fig.3)
3. Remove the tank and place in a sink with the cap facing upwards.
4. Gently slide upwards the air filter plastic holder. (See Fig.16)
5. Remove the filter combination from the plastic holder.
6. Gently rinse with water in the sink and dry with fabric towel before returning.
7. Replace the filter combination making sure that the coarse black filter is in contact with the plastic holder. (See Fig.17)
8. Replace the tank.
9. Close the drawer fully.
10. Press Switch 'A' to the 'ON' (🔥) position (See Fig.2)

Recycling.



For electrical products sold within the European Community. At the end of the electrical products useful life it should not be disposed of with household waste. Please recycle where facilities exist. Check with your Local Authority or retailer for recycling advice in your country.

After Sales Service.

Your product is guaranteed for one year from the date of purchase. Within this period, we undertake to repair or exchange this product free of charge (excluding lamps & subject to availability) provided it has been installed and operated in accordance with these instructions. Your rights under this guarantee are additional to your statutory rights, which in turn are not affected by this guarantee.

Should you require after sales information or assistance with this product please go to www.dimplex.co.uk where you will find our self help guide by clicking on "After Sales" or ring our help desk on 0845 600 5111 (UK) or 01 842 4833 (R. O. I.). Spare parts are also available on the web site.

Please retain your receipt as proof of purchase.

Troubleshooting		
Symptom	Cause	Corrective Action
The flame effect will not start.	Mains plug is not plugged in. Switch A is not in the 'ON' (🔥) position, (See Fig.2) Low water level. Low voltage connector not connected properly. (See Fig.7)	Check plug is connected to wall socket correctly. Press Switch A to the 'ON' (🔥) position, (See Fig.2) Check the water tank is full and there is water in the sump. Check that the connector is inserted correctly. (See Fig.)
The flame effect is too low.	Flame effect control knob is set too low. (See Fig.2) The water in the sump may be too high due to the drawer being opened and closed a number of times, water tank removed a number of times, or the fire has been moved. Metal Disc at the base of Sump might be dirty (See Fig.12)	Increase level of flame by turning Control knob C to the left slowly. (See Fig.2) If water level in the sump is more than 40mm, the sump should be removed and emptied in the sink. Clean Metal Discs with soft brush supplied. (See Fig.12) See 'Maintenance.' for a step by step procedure.
Unpleasant smell when unit is used.	Dirty or stale water. Using unfiltered tap water.	Clean the unit as described under maintenance. Use only filtered tap water.
The flame effect has too much smoke.	Flame effect setting is too high.	Turn the flame effect Control knob C to the right until it is at minimum and slowly turn to the left, about ¼ a turn, at a time. Give the flame generator some time to adjust before increasing. (See Fig.2)
Main lamps are not working and there are no flames or smoke.	There is no water in the tank.	Follow instructions under Maintenance , 'Filling the water tank'. Check the plug is connected to wall socket correctly. Switch 'A' Fig. 2 is in the 'ON' (🔥) position.
Condensation on inner glass surfaces	Glass surfaces may be cold	Open stove door slightly until glass warms up. Turn down flame effect during this process.

Opti-myst is a trade mark of GDC Group Ltd.

This product is protected by one or more of the following patents: PCT/ EP2005/009774, PCT/ EP2007/002207, GB0717773.6, GB0717772.8, GB0717770.2, GB0809322.1. The design of this product is protected by EU Design Rights

Dimplex
Millbrook House
Grange Drive
Hedge End
Southampton
Hampshire. SO30 2DF

www.dimplex.co.uk

Republic of Ireland Tel. 01 8424833

[c]A division of GDC Group Ltd.

All rights reserved. Material contained in this publication may not be reproduced in whole or in part, without prior permission in writing of GDC.