

Contact Details

Please note that some of the contact details on this PDF document may not be current.

Please use the following details if you need to contact us:

Telephone: 0844 879 3588

Email: customer.services@gdcgroup.co.uk

The customer support section of our website also features a wide range of information which may be of use to you and is available 24 hours a day. It includes:

- Operating and installation instructions
- Easy 'How to use' guides for storage heaters
- Service and repairs
- Where to buy our products
- Literature downloads
- Heating requirement calculator

Visit - www.dimplex.co.uk/support

Dimplex

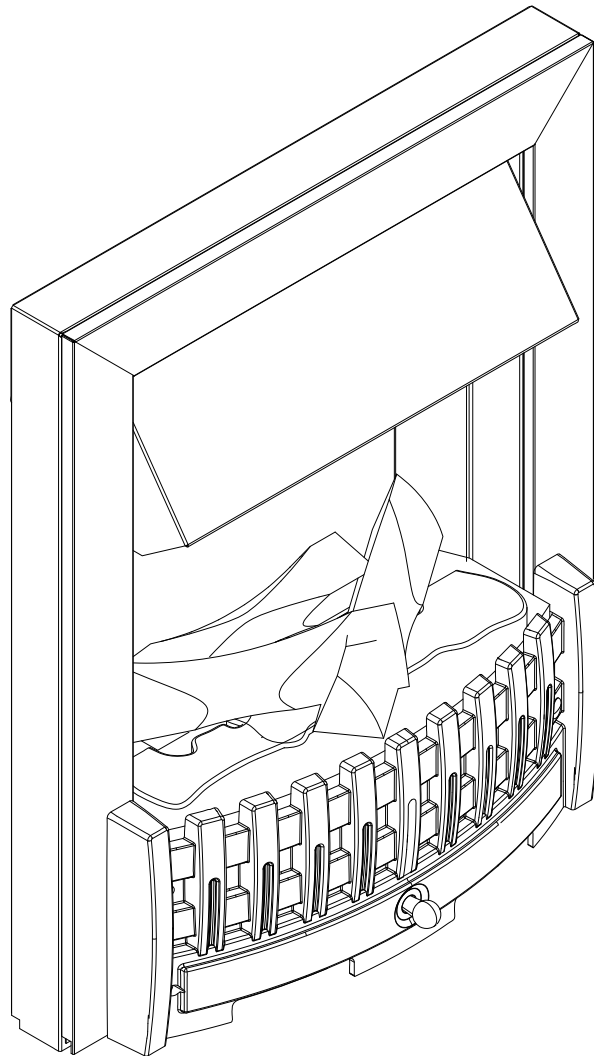

DANVILLE DNV20AB, DNV20BR, DNV20BL & DNV20CH

08/51445/0 Issue 3

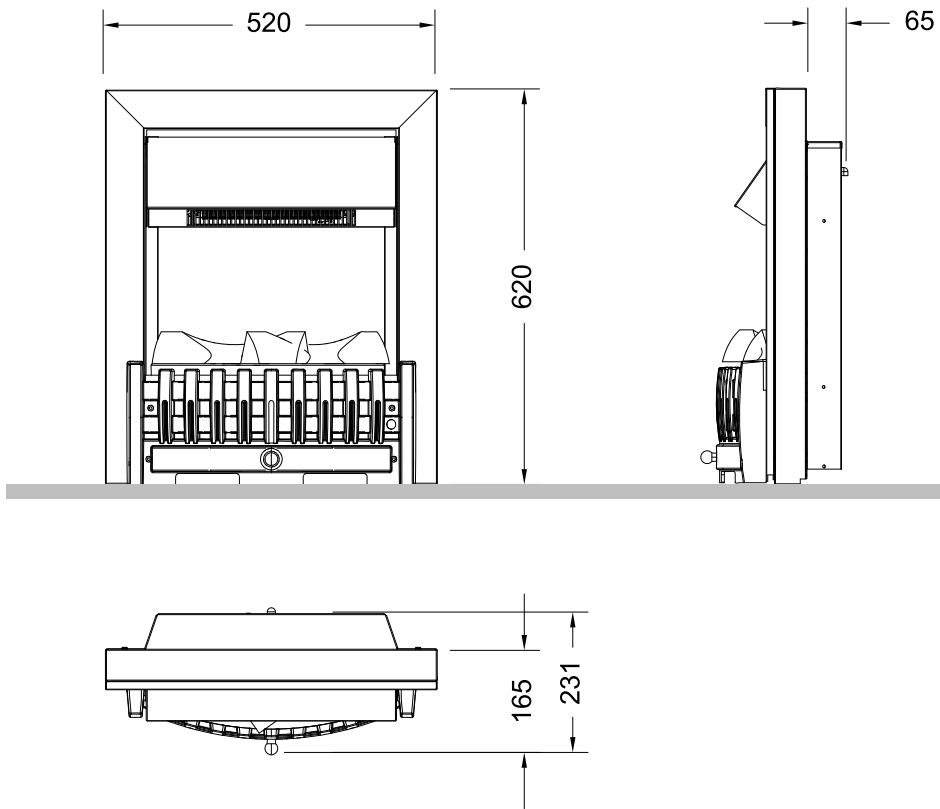

Fig.1

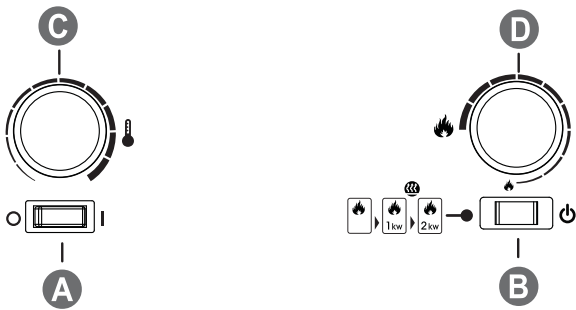

Fig.2

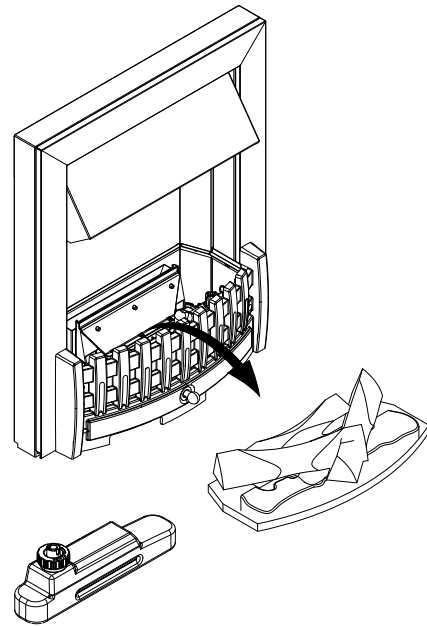

Fig.3

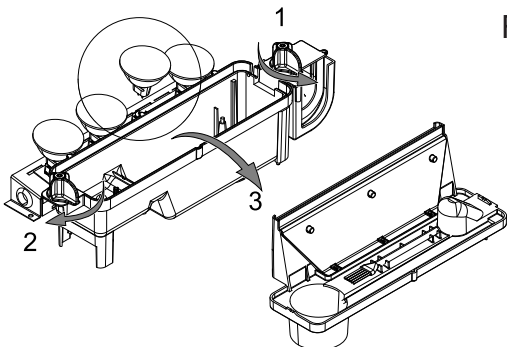
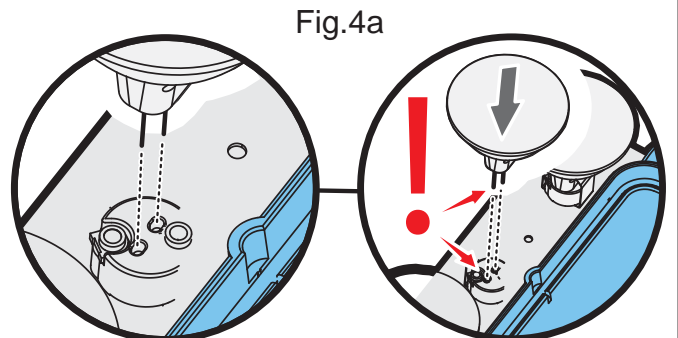

Fig.4



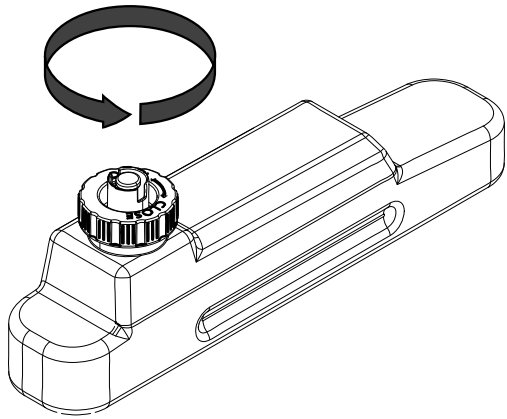

Fig.5

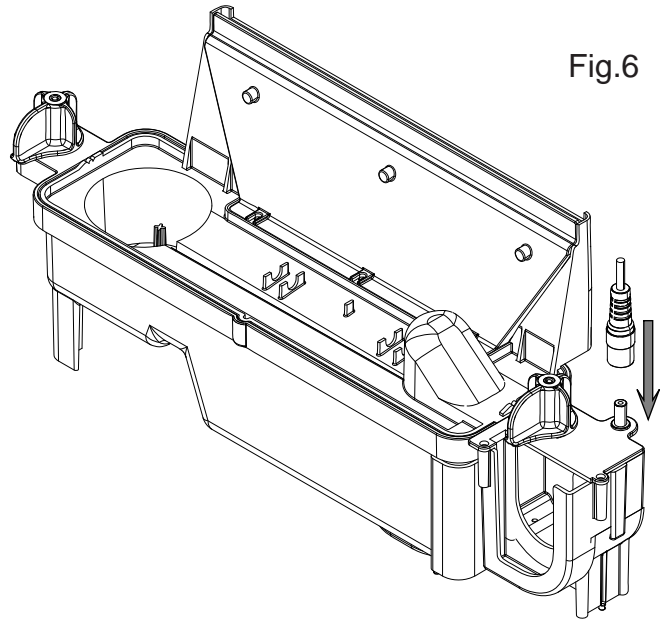

Fig.6

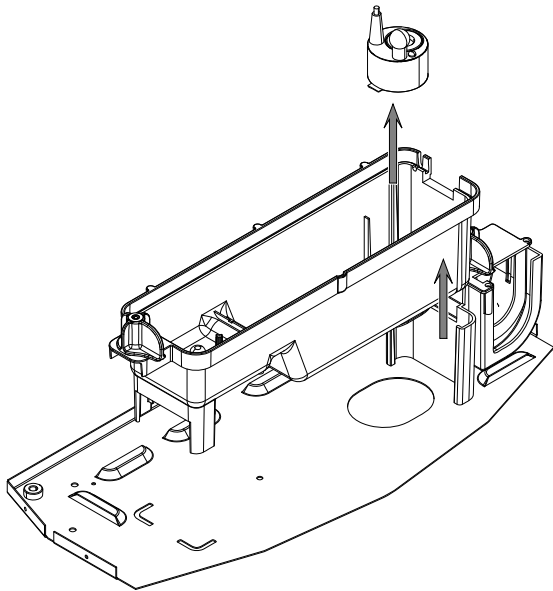

Fig.6a

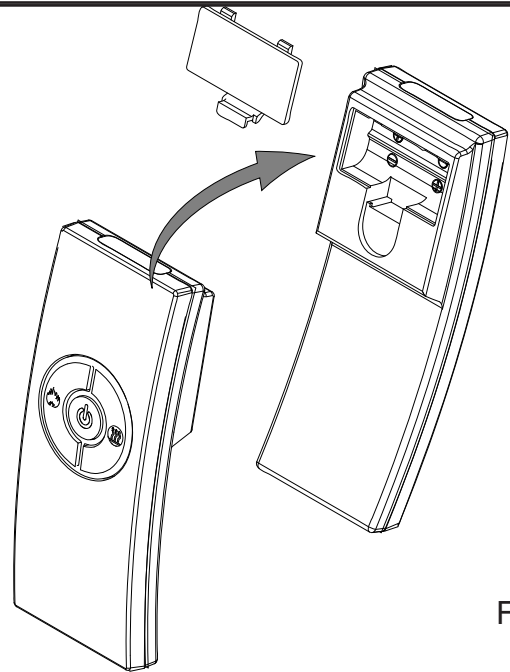

Fig.7



Fig.8

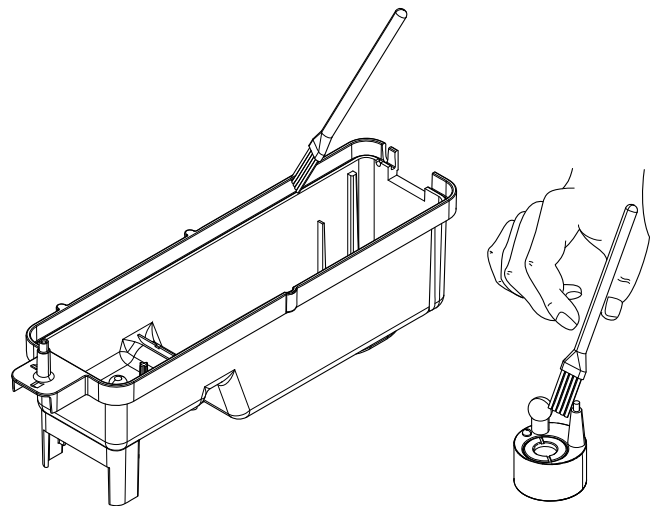

Fig.9

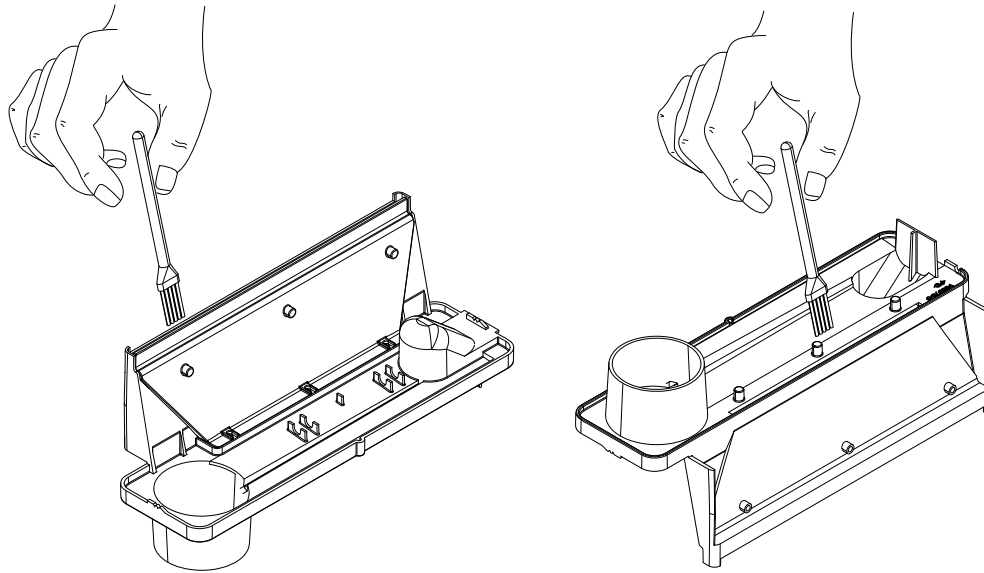

Fig.10

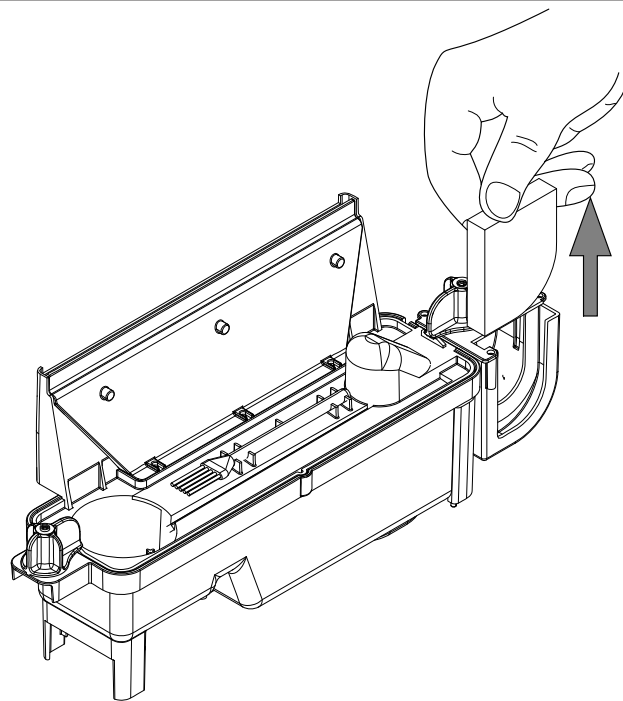

Fig.11

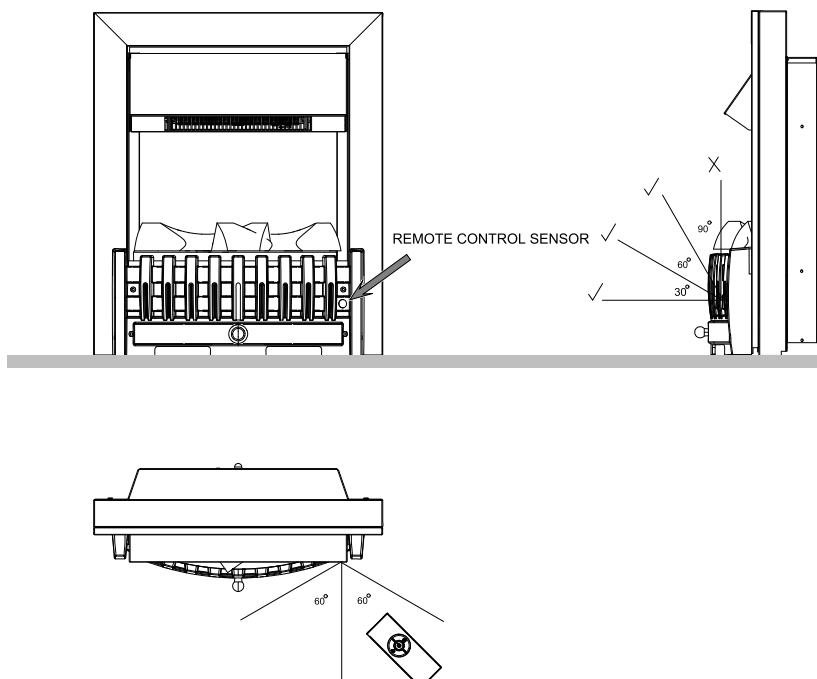

Fig.12

Dimplex Opti-myst Inset Fires

Model: DNV20AB, DNV20BR, DNV20BL, DNV20CH

IMPORTANT: THESE INSTRUCTIONS SHOULD BE READ CAREFULLY AND RETAINED FOR FUTURE REFERENCE

Important Safety Advice:

When using electrical appliances, basic precautions should always be followed to reduce the risk of fire, electrical shock and injury to persons, including the following:

If the appliance is damaged, check with the supplier before installation and operation.

Do not use outdoors.

Do not use in the immediate surroundings of a bath, shower or swimming pool.

Do not locate the heater immediately below a fixed socket outlet or connection box.

This appliance is not intended for use by children or other persons without assistance or supervision if their physical, sensory or mental capabilities prevent them from using it safely. Children should be supervised to ensure that they do not play with the appliance.

Do not use this heater in series with a thermal control, a program controller, a timer or any other device that switches on the heat automatically, since a fire risk exists when the heater is accidentally covered or displaced.

Ensure that furniture, curtains or other combustible material are positioned no closer than 1 metre from the heater.

In the event of a fault unplug the heater.

Unplug the heater when not required for long periods.

Although this heater complies with safety standards, we do not recommend its use on deep pile carpets or on long hair type of rugs.

The appliance must be positioned so that the plug is accessible.

If the supply cord is damaged it must be replaced by the manufacturer or service agent or a similarly qualified person in order to avoid a hazard.

Keep the supply cord away from the front of the heater.

WARNING: In order to avoid overheating, do not cover the heater. Do not place material or garments on the heater, or obstruct the air circulation around the heater.

The heater carries a DO NOT COVER warning.

General.

Unpack the heater carefully and retain the packaging for possible future use, in the event of moving or returning the fire to your supplier.

The fire incorporates a flame effect, which can be used with or without heating, so that the comforting effect may be enjoyed at any time of the year. Using the flame effect on its own only requires little electricity.

The heater is designed for use inset into a 407mm (16") or 457mm (18") wide by 559mm (22") high fireplace opening or freestanding - see also section 'Installation Instructions'.

A 2kw fan heater is discreetly positioned in the canopy of the fire provides heating in cold weather. Switching allows half or full heat. A distance of 1 metre (39") must be maintained between the front of the heater and any surrounding furniture, overhanging curtains or other obstructions.

To reduce heat loss and to prevent any chimney up draft affecting the operation of your inset fire we recommend they the chimney flue is sealed off.

Before connecting the heater check that the supply voltage is the same as that stated on the heater.

Please note: Used in an environment where background noise is very low, it may be possible to hear a sound which is related to the operation of the flame effect. This is normal and should not be a cause for concern.

Electrical connection.

WARNING – THIS APPLIANCE MUST BE EARTHED.

This heater must be used on an AC ~ supply only and the voltage marked on the heater must correspond to the supply voltage. Before switching on, please read the safety warnings and operating instructions.

PLEASE RETAIN THIS USER'S GUIDE FOR FUTURE REFERENCE

Only use filtered tap water in this appliance.

Always ensure that the appliance is sitting on a level surface.

If you intend not using the appliance for longer than 2 weeks, drain the water from sump and water tank and dry the sump.

Once installed, never move this appliance or lay on its back, without draining the water from sump and water tank.

The water tank, sump, sump lid, tank cap and air filters must be cleaned once every two weeks, particularly in hard water areas.

The appliance should never be operated if the lamps are not working.

The lamps should be regularly inspected as described under '[Maintenance](#)' and '[Changing lamps](#)'.

Installation Instructions

Before installing this appliance in an existing chimney, we recommend that;

1. You have your chimney cleaned by a competent chimney sweep.
2. You block off the chimney flue.

This procedure is important for the efficient operation of the heating unit and will also reduce heat loss up the chimney.

Installation.

Ensure that all packing items are removed (read any warning labels carefully).

Retain all packing for possible future use e.g. in the event of moving or returning the appliance to your supplier.

To install the appliance;

1. Clean the area where the fire will be installed e.g remove ash residue from an existing fireplace.
2. Use the two adjustable supports at the rear of the appliance to ensure that the fire is level.
3. Make sure the unit is switched **OFF**.
4. Hold the fire by the sides of surround and gently manoeuvre into position. Plug the fire into a 13amp/240 volt outlet. Ensure that the supply cable is not trapped under the fire such that it might cause it to be damaged.

Before using the manual controls firstly fill the water tank (See 'Maintenance', 'Filling the water tank').

Manual Controls.

The Opti-myst manual controls are located beneath the hinged canopy. Raise the canopy to access the controls. (See Fig.2 for Manual Control lay out)

Switch 'A':- Controls the electricity supply to the Fire.

Note: This switch must be in the 'ON' (I) position for the Fire to operate either with or without heat.

Switch 'B':- Press  once to turn on the flame effect. This will be indicated by an audible beep. Although the main lights operate immediately it will take a further 30 seconds before the flame effect starts.

Press  again to give flame effect and half heat. This will be indicated by two beeps.

Press  again to give flame effect and full heat. This will be indicated by three beeps.

Press  again to return to flame effect only. This will be indicated by one beep.

Press  to put fire in to standby mode. This will be indicated by one beep.

Control Knob 'C':- Controls the Thermostat setting.

Turning the control knob Anti Clockwise will decrease the temperature setting, turning the control knob Clockwise will increase the temperature setting.

Control Knob 'D':- Controls the intensity of the flame effect.

Turning the control knob Anti Clockwise increases the flame effect, turning the control knob Clockwise will decrease the flame effect.

When the water in the tank and in the sump runs out the main lamps will go out. See instructions under 'Maintenance', 'Filling the water tank'. When this procedure is complete, the main lamps will illuminate but it will take 30 seconds before the flames return.

Setting the Thermostat

Plug in and switch on the fire to the full heat setting. Turn the Control Knob 'C' fully clockwise (max temperature setting) to warm the room rapidly. When the room temperature has reached the desired level, turn the thermostat knob back slowly until you hear the thermostat just click off. The heater will then maintain the room temperature at the chosen level.

Note: Should your heater fail to come on when the thermostat is at a low setting, this may be due to the room temperature being higher than the thermostat setting

Thermal safety cut-out

A thermal safety cut-out is incorporated in the fan heater to prevent damage due to overheating. This can happen if the heat outlet was restricted in any way or if the chimney flue has not been blocked off effectively. If the cut-out operates, unplug the heater from the socket outlet and allow approximately 10 minutes before reconnecting. Before switching the heater back on remove any obstruction that may be restricting the heat outlet, then continue normal operation.

Caution: In order to avoid a hazard due to inadvertent resetting of the thermal cutout, this appliance must not be supplied through an external switching device, such as a timer, or connected to a switch that is regularly switched on and off by the utility.

Tips for using your appliance.

1. With the flame setting on minimum the unit will use approximately 40ml of water per hour and will last 3 times as long than when it is at maximum flame setting.
2. Do not tilt or move the fire while there is water in the tank or sump.
3. Make sure that the fire is on a level floor.
4. The flame control knob 'D' Fig.2 may be turned up or down to give a more realistic effect.
5. Sometimes the flames appear more real when the flame control knob is turned down.
6. Give the flame generator some time to react to changes you may make on the flame control knob.

Maintenance

WARNING: ALWAYS DISCONNECT FROM THE POWER SUPPLY BEFORE BEGINNING ANY MAINTENANCE

Changing lamps.

If the smoke appears grey or colourless it may be that one or more lamps have failed.

You can check for lamp failure as follows.

1. Leaving the flame effect on, lift out the fuelbed and water tank. (See Fig.3)
2. It should be possible to view the lamps with the nozzle (See Fig.4) in place and observe which one needs to be changed.
3. Put Switch 'A' in the 'OFF' position, and unplug the fire from the mains.
4. Leave the appliance for 20 minutes to allow the lamps to cool down before removing them.
5. Remove the sump as described in the Cleaning Section.
6. Remove the defective lamp, by gently lifting vertically and disengaging the pins from the lamp holder, (See Fig.4 and 4a). Replace with a Dimplex Opti-myst, 12V, 50W, Gu5.3 base, 8° beam angle, coloured lamp. (Purchased from www.dimplex.co.uk under the section 'After Sales Service', details of how to purchase the lamps are contained therein.)
7. Carefully insert the two pins of the new lamp into the two holes in the lamp holder. Push firmly in place. (See Fig.4 and 4a).
8. Replace the sump, nozzle, water tank and fuelbed.
9. Switch on.

Filling the water tank.

When the water tank is empty, the flame and smoke effect shuts off and you will hear 2 audible beeps, follow these steps.

1. Press Switch 'A' to **(0)** (See Fig.2)
2. Gently lift out the fuelbed and set aside carefully. (See Fig.3)
3. Remove the water tank by lifting upwards and outwards.
4. Place the water tank in sink and remove cap, Anti-clockwise to open. (See Fig.5)
5. Fill tank with **filtered tap water only**. This is necessary to prolong the life of the flame and smoke producing unit. The water should be filtered through a conventional domestic water filter unit and the filter should be replaced regularly.
6. Screw the cap back on, **do not overtighten**.
7. Return the tank to the sump, with the tank cap facing down and the flat side of the tank facing outward.
8. Gently place the fuelbed back into position.
9. Press Switch 'A' to 'ON' (I) position (See Fig.2)

Cleaning.

WARNING – ALWAYS DISCONNECT FROM THE POWER SUPPLY BEFORE CLEANING THE HEATER.

We recommend cleaning the following components once every 2 weeks, particularly in hard water areas:-

Water Tank, Sump, Nozzle, Tank cap and seal, Air filter.

For general cleaning use a soft clean duster – never use abrasive cleaners. To remove any accumulation of dust or fluff the soft brush attachment of a vacuum cleaner should occasionally be used to clean the outlet grille of the fan heater.

Water tank

1. Remove water tank, as described earlier, put into sink and empty water.
2. Using the supplied brush gently rub the inside surfaces of the cap paying particular attention to the rubber ring in the outer groove and the centre rubber seal.
3. Put a small quantity of washing up liquid into the tank, refit the cap and shake well, rinse out until all traces of washing up liquid are gone.
4. Refill with filtered tap water only, replace the cap, do not overtighten.

Sump

1. Press Switch 'A' to the 'OFF' **(0)** position
2. Gently lift out the fuelbed and place carefully on the ground. (See Fig.3)
3. Remove the water tank by lifting upwards.
4. Disconnect the electrical connector, located on the right side of the sump. (See Fig.6) .
5. Release the right sump locking tabs by turning 90°, this allows the sump to be lifted completely from its location. (See Fig.6a)
6. Gently lift up the sump, taking care to keep level so as not to spill any water. Sit the assembly in the sink.
7. Release the left sump locking tabs by turning 90°, then lift off the Nozzle. (See Fig.4)
8. Lift out the transducer and carefully tilt, as shown, so that the liquid drains out of the sump. (See Fig.8)

9. Put a small amount of washing up liquid into the sump, and using the supplied brush, gently clean all surfaces in the sump and gently clean the transducer including the metal discs located in the top grooved surface. (See Fig.9)
10. When cleaned, thoroughly rinse the sump with clean water to remove all traces of washing up liquid.
11. Clean the outlet surface of the sump lid with the brush and flush out thoroughly with water. (See Fig.10)
12. Reverse the above steps to reassemble.

Air filter.

1. Press Switch 'A' to the 'OFF' (0) position (See Fig.2)
2. Gently lift out the fuelbed and place carefully on the ground. (See Fig.3)
3. Gently slide the air filter upwards out of its plastic holder. (See Fig.11)
4. Gently rinse with water in the sink and dry with fabric towel before returning.
5. Replace the filter making sure that the coarse black filter is facing the front of the fire.
6. Replace the fuelbed.
7. Press Switch 'A' to the 'ON' (I) position (See Fig.2)

Remote Control Operation

On the control panel, Switch A (see Fig.2) must be in the 'ON' (I) position in order for the remote control to operate. There are 3 buttons on the remote control. (See Fig.7) To operate correctly the remote must be pointed towards the front of the grate. (See Fig 12). The remote control functions are as follows:



Press once to turn on Flame effect only.
This will be indicated by one beep.



Press once to turn on Half Heat and Flame Effect.
This will be indicated by two beeps.
Press again to turn on Full Heat and Flame Effect.
This will be indicated by three beeps.



Standby
This will be indicated by one beep.

Recycling.



For electrical products sold within the European Community. At the end of the electrical products useful life it should not be disposed of with household waste. Please recycle where facilities exist. Check with your Local Authority or retailer for recycling advice in your country.

After Sales Service.

Your product is guaranteed for one year from the date of purchase. Within this period, we undertake to repair or exchange this product free of charge (excluding lamps & subject to availability) provided it has been installed and operated in accordance with these instructions. Your rights under this guarantee are additional to your statutory rights, which in turn are not affected by this guarantee.

Should you require after sales information or assistance with this product please go to www.dimplex.co.uk where you will find our self help guide by clicking on "After Sales" or ring our help desk on 0845 600 5111 (UK) or 01 842 4833 (R. O. I.). Spare parts are also available on the web site. Please retain your receipt as proof of purchase.

Patent / Patent Application

Products within the Optimyst range are protected by one or more of the following patents and patent applications:

Great Britain GB 2402206, GB 2460259, GB 2460453 , GB 2418014, GB 2465738, GB 2449925, GB 2465537 , GB 2455277 , GB1020534.2, GB1020537.5, GB1110987.3

United States US 7967690, US 2010299980, US 2011062250, US 2008028648, US 13/167,042

Russia RU2008140317

European EP 2029941, EP 2201301, EP 2315976, EP 1787063, EP07723217.1 , EP11170434.2, EP 11170435.9

China CN 101883953, CN 200980128666.2, CN 101057105, CN 101438104

Australia AU 2009248743, AU 2007224634

Canada CA 2725214, CA 2579444, CA 2645939

International Patent Application WO 2006027272

South Africa ZA 200808702

Mexico MX 2008011712

Korea KR 20080113235

Japan JP 2009529649

Brasil BR P10708894-9

India IN 4122/KOLNP/2008

New Zealand NZ 571900

Troubleshooting

Symptom	Cause	Corrective Action
The flame effect will not start.	<p>Mains plug is not plugged in.</p> <p>Low water level.</p> <p>Low voltage connector not connected properly. (See Fig.6)</p> <p>The Transducer Unit is not sitting correctly in the sump</p>	<p>Check plug is connected to wall socket correctly.</p> <p>Check that the water tank is full and there is water in the sump.</p> <p>Check that the connector is inserted correctly. (See Fig.6)</p> <p>Ensure the Transducer is sitting down into the moulded recess in the sump</p>
The flame effect is too low.	<p>Flame effect control knob is set too low. (See Fig.2)</p> <p>The Metal Disc in the transducer might be dirty (See Fig.12)</p> <p>The wire from the Transducer Unit is sitting over the metal disc</p>	<p>Increase level of flame by turning Control knob 'D' anti clockwise slowly. (See Fig.2)</p> <p>Clean the Metal Disc with soft brush supplied. (See Fig.12) See 'Maintenance' for a step by step procedure.</p> <p>Direct the wire to the back of the sump and make sure it sits into the side slot exiting the sump.</p>
Unpleasant smell when unit is used.	<p>Dirty or stale water.</p> <p>Using unfiltered tap water.</p>	<p>Clean the unit as described under maintenance.</p> <p>Use only filtered tap water.</p>
The flame effect has too much smoke.	<p>Flame effect setting is too high.</p>	<p>Turn the flame effect Control knob C clockwise, about ¼ a turn, at a time. Give the flame generator some time to adjust to the new setting. (See Fig.2)</p>
Main lamps are not working and there are no flames or smoke.	<p>There is no water in the water tank</p>	<p>Follow instructions under Maintenance, 'Filling the water tank'.</p> <p>Check the plug is connected to the wall socket correctly and that Switch 'A' Fig. 2 is in the 'ON' (I) position.</p>

Opti-myst is a trade mark of GDC Group Ltd.

DIMPLEX
MILLBROOK HOUSE
GRANGE DRIVE
HEDGE END
SOUTHAMPTON
SO30 2DF

TEL: 0845 600 5111
FAX: 01489 773050
WEBSITE: www.dimplex.co.uk

Republic of Ireland Tel. 01 8424833

[c] GDC Group Ltd,
All rights reserved. Material contained in this publication may not be reproduced in whole or in part, without prior permission in writing of Dimplex.
A division of GDC Group Ltd,