



Celena

CONVENTIONAL FLUE LOG EFFECT GAS FIRE

Installation, Maintenance & User Instructions

Hand these instructions to the user

Model No. BPRL**RN is only for use on Natural Gas (G20) at a supply pressure of 20 mbar in G.B. / I.E.

** denotes cosmetic variant

CONTENTS

Section 1	Information and Requirements	PAGE
1.0	Appliance Information	3
1.1	Conditions of Installation	4
1.2	Flue and chimney suitability	4
1.3	Fireplace / surround suitability	5
1.4	Shelf position	5
1.5	Chimney inspection	5
1.6	Fire place opening / catchment space	6-7
1.7	Chair bricks	8
1.8	Metal flue boxes	8
1.9	Spillage monitoring system	9
Section 2	Installation of Fire	
2.1	Unpacking the fire	10
2.2	Installing the fire box	10-18
2.3	Gas tightness and inlet pressure	19
2.4	Installing the Rennes surround	20-21
2.5	Installing the Avignon surround	22-23
2.6	Installing the Etienne surround	24-25
2.7	Checking mechanical fixing of all surround types	26
Section 3	Assembling Fuel Bed and Commissioning	
3.1	Fitting the log fuelbed	27-31
3.2	Fitting the batteries	32
3.3	Operation of the fire	33-37
3.4	Lighting the fire	37-40
3.5	Advanced settings of remote control	40-44
3.6	Checking for clearance of combustion products	45
3.7	Removal / re-fitting the restrictor baffle	46
3.8	Fitting the optional trim assembly	46
Section 4	Maintenance	
4.1	Removal of the burner assembly	47
4.2	Removal of the control valve	47-48
4.3	Removal of the oxy-pilot	48
4.4	Replacing the battery in the handset	49
4.5	Replacing the batteries in the fire	49
4.6	Access and checking the flue debris void	49
4.7	Spare parts shortlist	50
Section 5	User Instructions Section	
5.1	Conditions of installation	51
5.2	About your new fire	52
5.3	Operating the fire	53-56
5.4	Changing the batteries in handset and in the fire	57
5.5	Setting the time, date and temperature on the remote handset	58-61
5.6	Advanced settings of the remote control	62-65
5.7	Cleaning instruction	66
5.6	Removal / re-fitting the glass panel	67
5.7	Removal / replacement of the fuelbed	68-72
5.8	User replaceable parts	73

This appliance is manufactured by :- BFM Europe Ltd, Trentham Lakes, Stoke-on-Trent, ST4 4TJ.

SECTION 1 INFORMATION AND REQUIREMENTS

1.0 APPLIANCE INFORMATION

Model	BPRL**RN
Gas Type	G20
Main injector (1 off)	Cat 82 size 360
Pilot Type	ERTA-PG-82-330
Max. Gross Heat Input :	5.4kW
Min. Gross Heat Input :	3.7kW
Cold Pressure :	20.0 +/-1.0 mbar
Ignition :	Via remote, integral to control system
Electrode Spark Gap	4.0mm
Packed Weight	35kg
Gas Connection :	8mm Compression (supplied with fire)

Fig. 1

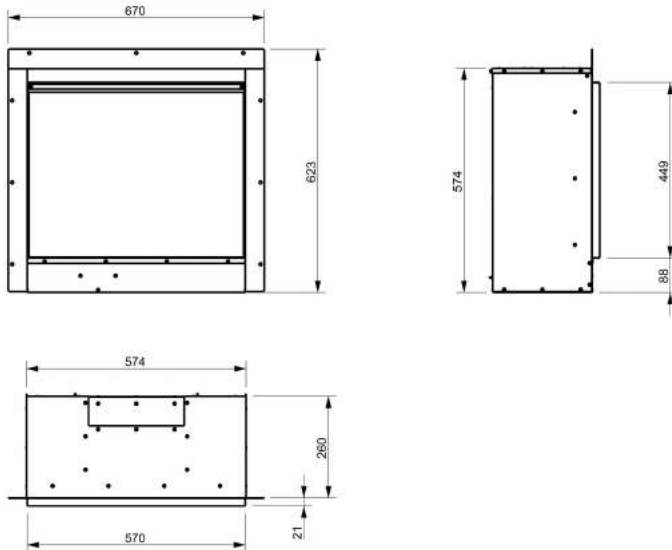

Appliance Efficiency Declaration

The efficiency of this appliance has been measured as specified in BS 7977-1 : 2009 +A1 : 2013 and the result is 79.6%. The net calorific value of the fuel has been used for this efficiency calculation.

The test data from which it has been calculated has been certified by BSI. The efficiency value may be used in the UK Government's Standard Assessment Procedure (SAP) for energy rating of dwellings.

INSTALLATION REQUIREMENTS

1.1 CONDITIONS OF INSTALLATION

It is the law that all gas appliances are installed only by a GAS SAFE Registered Installer, in accordance with these installation instructions and the Gas Safety (Installation and Use) Regulations 1998 as amended. Failure to install appliances correctly could lead to prosecution. It is in your own interest and that of safety to comply with the law.

The installation must also be in accordance with all relevant parts of the Local and National Building Regulations where appropriate, the Building Regulations (Scotland Consolidation) issued by the Scottish Development Department, and all applicable requirements of the following British Standard Code of Practice.

1. B.S. 5871 Part 2 Installation of Inset Fuel Effect Gas Fires
2. B.S. 6891 Installation of Gas Pipework
3. B.S. 5440 Parts 1 & 2 Installation of Flues and Ventilation
4. B.S. 1251 Open fire place components
5. B.S. 715 Metal flue pipes for gas appliances
6. B.S. 6461 Part 1 Installation of Chimneys and flues
7. B.S. E.N. 1858 Chimneys Components & Concrete Flue Blocks
8. I.S. 813 : 1996 Domestic Gas Installation (Republic of Ireland)

No purpose made additional ventilation is normally required for this appliance, when installed in G.B. When installing in I.E. please consult document I.S. 813 : 1996 Domestic Gas Installation, which is issued by the National Standards Authority of Ireland. If installing in Northern Ireland, please consult local building regulations. Any purpose made ventilation must be checked periodically to ensure that it is free from obstruction.

1.2 FLUE AND CHIMNEY SUITABILITY

This appliance is designed for use with conventional brick built or lined chimneys and fabricated flues conforming to BS 715. All flues must conform to the following minimum dimensions.

Minimum diameter of circular flues	125 mm (without flue restrictor fitted)
Minimum effective height of all flue types	3 metres

When fitting to conventional chimneys or 175mm flues it may be desirable to leave the flue restrictor baffle (supplied) in place to reduce the flue flow and increase the efficiency of the fire. Safe clearance of products must always be checked by carrying out a smoke match test as described.

1.3 FIREPLACE / SURROUND SUITABILITY

The fire must not be installed directly onto carpet or other combustible floor materials.

If a heating appliance is fitted directly against a wall combustible material must be removed from behind it. Soft wall coverings such as blown vinyl, wall paper etc. could be affected by the rising hot air and scorching and/or discoloration may result. Due consideration should be made to this when installing or decorating.

1.4 SHELF POSITION

The fire may be fitted below a combustible shelf providing there is a minimum distance of 200mm above the top of the fire and the shelf does not project more than 150mm. If the shelf overhangs more than 150mm the distance between the fire and the shelf must be increased by 15mm for every 25mm of additional overhang over 150mm.

1.5 FLUE / CHIMNEY INSPECTION

Before commencing installation, a flue or chimney should be inspected to ensure that all the following conditions are satisfied.

1. Check that the chimney / flue only serves one fire place and is clear of any obstruction. Any dampers or register plates must be removed or locked in the open position.
2. Brick/stone built chimneys or any chimney or flue which has been used for an appliance burning fuel other than gas must be thoroughly swept. The base of the chimney / flue must also be thoroughly cleared of debris etc.
3. Any under-floor air supply to the fire place must be completely sealed off.
4. Ensure that the inside of the chimney / flue is in good condition along its length and check that there is no leakage of smoke through the structure of the chimney during and after the smoke pellet test.
5. **Using a smoke pellet, check that there is an up-draught in the chimney / flue and that the smoke can be seen issuing from the terminal / chimney pot outside. There must be no leakage of smoke through the structure of the chimney during or after the smoke pellet test and it is important to check inside upstairs rooms adjacent to the chimney / flue.** Check the chimney pot / terminal and general condition of the brickwork or masonry. If the chimney or flue is in poor condition or if there is no up-draught do not proceed with the installation. If there is a history of down-draught conditions with the chimney / flue, a tested and

certificated flue terminal or cowl suitable for the relevant flue type should be considered.

6. **A spillage test must always be carried out during commissioning of the appliance.**

1.6 FIRE PLACE OPENING

1.6.1 Fireplace Opening for Engine Only Applications

The front opening of the fire place must be between 580mm and 600mm wide, between 580mm and 600mm high and 300mm deep. If the opening exceeds these dimensions then a surround must be constructed from suitable non-combustible material to produce a correct size opening. Any surround must be suitably sealed to the fire place to prevent leakage. See below in figure 2.

Fig. 2

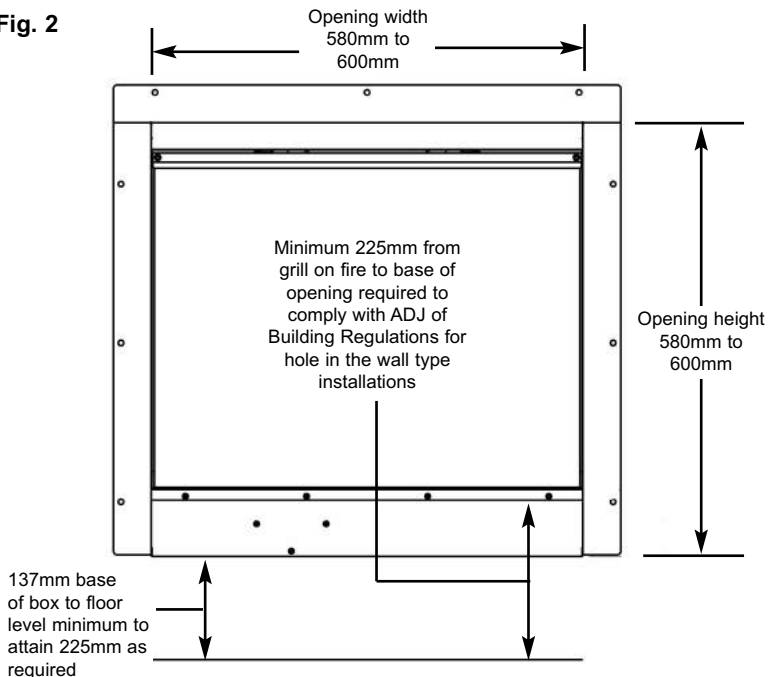

NOTE :- If installing with a retailer designed surround package **please consult the retailer to determine installation height required for the fire.**

When installing into a brick built chimney, you must ensure that there is sufficient depth to accommodate any debris which may fall from the chimney. This depth must be sufficient to accommodate 12 litres of volumetric space in a conventional brick built chimney.

1.6.2 Fireplace Opening for Rennes, Avignon & Etienne Surround Types

If fitting this fire with a surround supplied from “BFM Europe” then the fireplace opening of width / height of 580mm minimum to 600mm maximum needs to be prepared at differing heights dependent upon which surround type is to be installed. See figure 3 below for individual heights required by surround type. There are mounting platforms available as optional extra's from the manufacturer to assist with installation, for Rennes & Avignon surrounds please request part no. 1176-182550 and for the Etienne surround please request part no. 1176-182540.

Fig. 3

Rennes Surround

Opening to be 117mm from floor level to base of opening

Use mounting platform Part No. 1176-182550

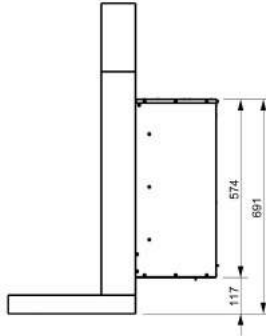

Etienne Surround

Opening to be 67mm from floor level to base of opening

Use mounting platform Part No. 1176-182540

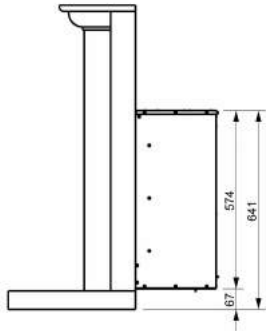

Avignon Surround

Opening to be 107mm from floor level to base of opening

Use mounting platform Part No. 1176-182550

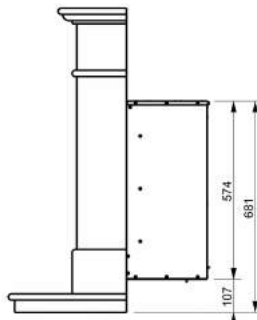
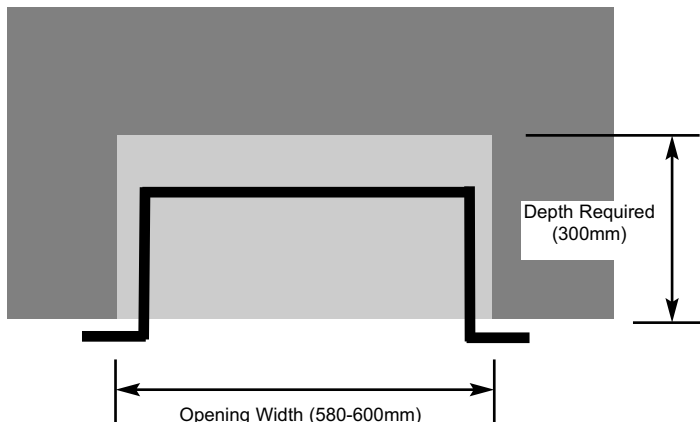

Table A - Installation Depth Requirements for BFM Fires Celena being installed into a brick built chimney, requiring 12.0 litres of debris collection volume (figure 4).

Opening Width (mm)	Minimum Depth Required (mm)
580-600mm	300mm

Fig. 4



1.7 FITTING TO FIREPLACES WITH EXISTING CHAIRBRICKS AND CONVENTIONAL BRICKBUILT CHIMNEYS

This appliance is not suitable for use in fireplaces fitted with an existing chairbrick without the removal of the chairbrick.

1.8 FITTING TO PRE-FABRICATED TWIN WALL METAL FLUE BOXES

The appliance may be fitted to twin wall metal flue boxes conforming to the constructional requirements of BS 715. The top face of the box must be insulated with a minimum thickness of 50mm of non-combustible mineral wool insulation or similar material. The flue box must stand on a non-combustible base of minimum thickness 12mm. A suitable box is available from the manufacturer, please quote part number 1176-180120.

1.9 SPILLAGE MONITORING SYSTEM

This appliance is fitted with an atmosphere sensing spillage monitoring system in the form of an oxygen sensing burner. This is designed to shut the fire off in the event of a partial or complete blockage of the flue causing a build up of combustion products in the room in which the fire is operated. **The following are important warnings relating to this spillage monitoring system :-**

- 1.9.1 The spillage monitoring system must not be adjusted by the installer.
- 1.9.2 The spillage monitoring system must not be put out of operation.
- 1.9.3 When the spillage monitoring system is exchanged only a complete original manufacturers part may be fitted.

SECTION 2 INSTALLATION OF FIRE

2.1 UNPACKING THE FIRE

Carefully lift the fire out of the carton. Remove the loose item packaging, check the contents as listed below :-

NOTE : DO NOT UNDER ANY CIRCUMSTANCES USE THIS APPLIANCE IF THE GLASS PANEL IS BROKEN OR NOT SECURELY FIXED TO THE FIREBOX.

Packing Check List - All Models

Pack 1 - Fire Pack

- 1 off Combustion chamber / burner
- 1 off Boxed ceramic fuel-bed set (packed inside combustion chamber)
- 1 off Loose items pack – containing :-
 - 1 off fixing kit
 - 1 off handset
 - 5 off AA batteries
 - 1 off Installation / user manual

Pack 2 - Optional Trim (If selected)

- 1 off 4 sided trim assembly (magnets supplied fitted on mounting flange of fire)

Pack 3 - Surround (If selected)

- 1 off Supplied in wooden crate, see section 2.4, 2.5 & 2.6

2.2 INSTALLING THE FIRE BOX

Establish which type of flue you are intending to install the fire in to :-

225 x 225mm (9 inch x 9 inch) brick built chimneys

175mm (7 inch) diameter lined brick or stone flue, or insulated pre-fabricated metal flue box to B.S. 715.

When installing into 125mm (5 inch) diameter lined brick or stone flue, or insulated pre-fabricated metal flue box to B.S. 715, the restrictor baffle must not be fitted.

A spillage test must always be carried out to check satisfactory clearance of flue products, regardless of the type of flue the appliance is being fitted to.

2.2.1 Remove the front grill by lifting clear and unplug the battery box as shown below in figure 5.

Fig. 5

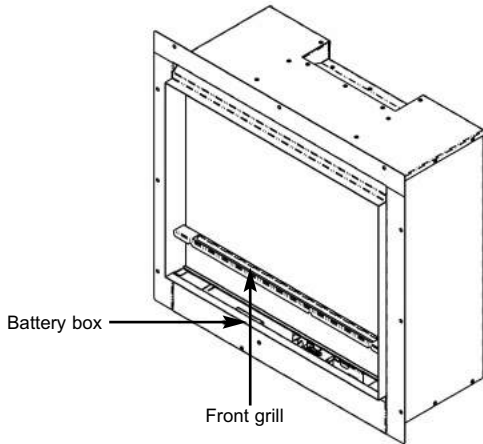

2.2.2 Remove the two off screws which secure the glass panel retaining bracket as shown below in figure 6, then tilt the glass panel forward to remove it. Take care not to allow the glass panel to fall forwards under its own weight.

Fig. 6

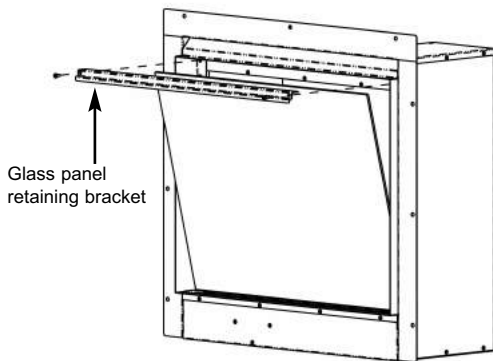

- 2.2.3 Store the glass panel in a safe place.
- 2.2.4 Re-assemble in reverse order when re-fitting the glass assembly.
- 2.2.5 **DO NOT OPERATE THE FIRE WITHOUT THE GLASS PANEL IN POSITION OR NOT CORRECTLY LOCATED.**

2.2.6 Remove the burner. To allow burner removal, the ceramic support panel must be removed to allow access to the burner fixings. Remove the 4 off ceramic support retaining screws as shown below in figure 7.

Fig. 7

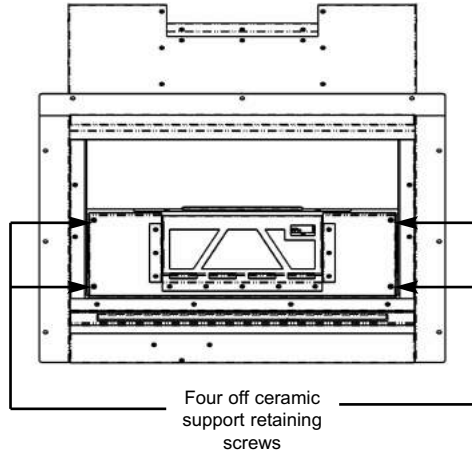

2.2.7 Remove the 4 off screws that hold the burner in position, see figure 8 below.

Fig. 8

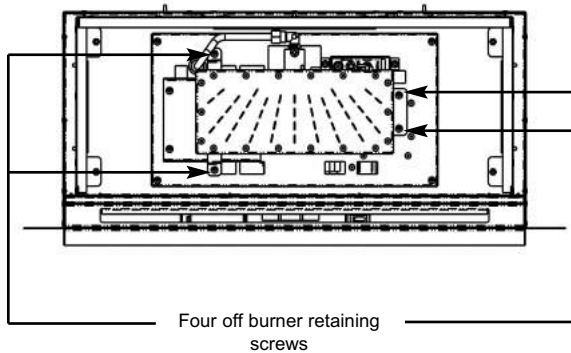

2.2.8 Loosen screw holding injector, the burner can then be slid forward and lifted clear as shown below in figure 9.

Fig. 9

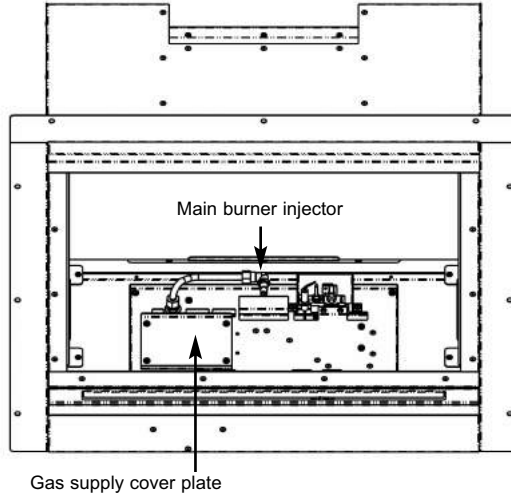

2.2.9 As shown in figure 9 above the gas supply cover plate should be removed, allowing access to the gas inlet valve and pressure test point as shown below in figure 10.

Fig. 10

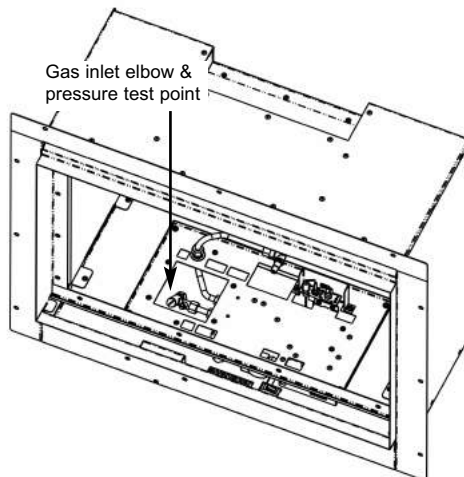

2.2.10 The burner base plate can now be removed by removing the four screws and lifting clear as shown below in figure 11. Tilt the assembly up at the back as it is removed to clear the on/off switch from the inlet channel.

Fig. 11

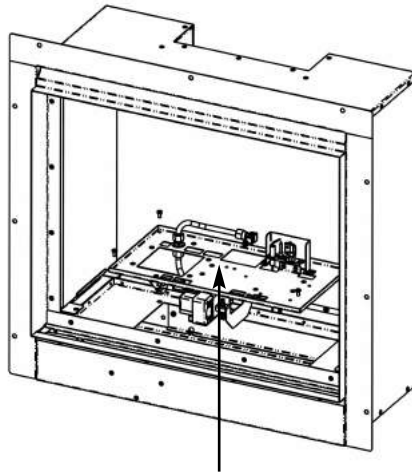

Burner base plate held in position by 4 off screws

2.2.11 The gas supply can be routed into the fire from the left, see figure 12 below for dimensional information regarding position and route of gas supply pipe.

Fig. 12

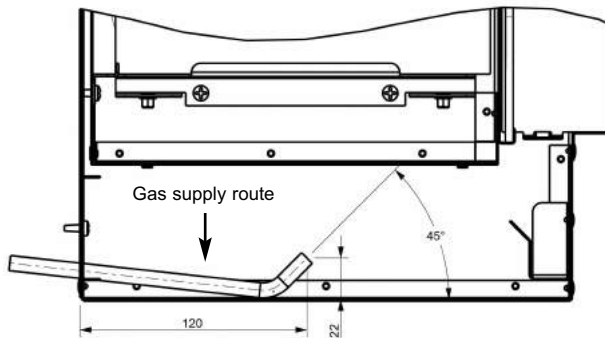

- 2.2.12 Store the removed burner components in a safe position.
- 2.2.13 The gas connection to the appliance should be made to the isolating / inlet elbow using 8mm rigid tubing. There must be no soldered joints within the firebox.
- 2.2.14 Ensure that the hearth (if fitted) is protected from damage and carefully lift the fire box into the fire opening, then slide it back into position. Check that the fire box flange fits flush to the sealing face of the fire surround or wall with no gaps present.

Note : Before breaking into the gas supply a pressure drop test should be carried out to establish that the existing pipework is sound.

- 2.2.15 Carefully withdraw the fire box from the opening to enable the gas supply and fire fixing to be completed.

There is a choice of methods of fixing the firebox which are provided to enable the installer to deal with any type of installation.

The preferred method of fixing which is suitable for almost all situations is the cable fixing method which is described in the following section in detail.

The fire may be secured using the cable method as described below, or alternatively, in installations where the cable method is not suitable (eg. loose masonry in rear of fire opening) the fire box can be directly secured to the fire surround using screw fixings (not provided).

To fit using the **preferred** cable method proceed as follows-

- 2.2.16 Mark out and drill 4 off No 14 (7mm) holes in the back face of the fire opening in the positions shown below in figure 13.

Fig. 13

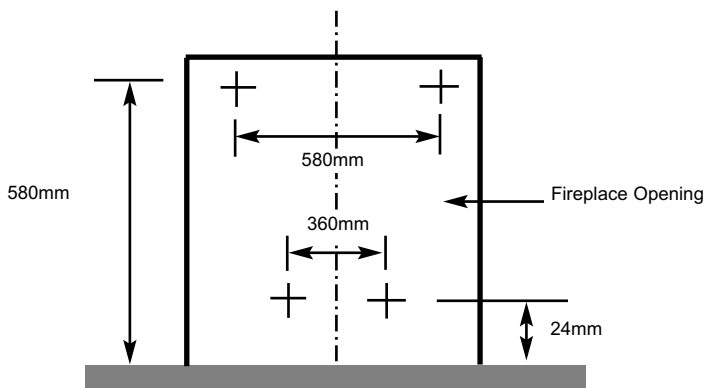

Fit the wallplugs provided and screw the fixing eyes securely into the rear of the fire opening. If the clearance at the rear of the fire is at the minimum specified for a precast flue application, it may be necessary to bend over the lower fixing eyes after screwing them fully in to the rear of a pre-cast starter block.

- 2.2.17 Uncoil the two fire fixing cables and thread one end of each of the cables through one of the two cable holes on each side of the rear brackets on the firebox (see figure 14 on page 18 for details of these holes)
- 2.2.18 Position the fire carefully on the (protected) surface of the hearth and reach into the fire opening. Thread each of the cables vertically downwards through the pair of fixing eyes on the same side of the fire. Thread the free end of the cables through the corresponding circular hole on each side of the lower rear of the fire. Carefully slide the fire box back into the fire opening and pull both cables tight.
- 2.2.19 Thread a tensioning screw over each of the cables and ensure that the tensioning nut is screwed fully up against the hexagon shoulder of the tensioning screw (this provides maximum travel for the tensioning nut).
- 2.2.20 Fit a screwed nipple on to each of the cables and pull hand tight up against the tensioning screw, then secure each nipple with a screwdriver.
- 2.2.21 Evenly tighten the tensioning nuts to tension both cables and pull the fire snugly against the wall. Do not overtighten, it is only necessary to pull the seal up against the sealing face of the wall, it does not need to be compressed. Check that there are no gaps behind the seal.
- 2.2.22 Refit the burner in reverse order to which it was removed.

NOTE : ENSURE THAT THE ON/OFF SWITCH ON THE CONTROL VALVE IS IN THE “ON” POSITION BEFORE RE-FITTING THE BURNER UNIT

- 2.2.23 **Before making the final gas connection, thoroughly purge the gas supply pipework to remove all foreign matter, otherwise serious damage may be caused to the gas control valve on the fire.**

The other firebox fixing method is as follows :-

2.2.24 In installations where the cable method is not suitable (e.g. loose masonry in rear of fire opening) the firebox can be secured to the opening using four screws and wall plugs (not provided). Below (figure 14) is a diagram to indicate the hole centre positions available on the firebox to facilitate the screw fixing to the fireplace / surround.

Fig. 14

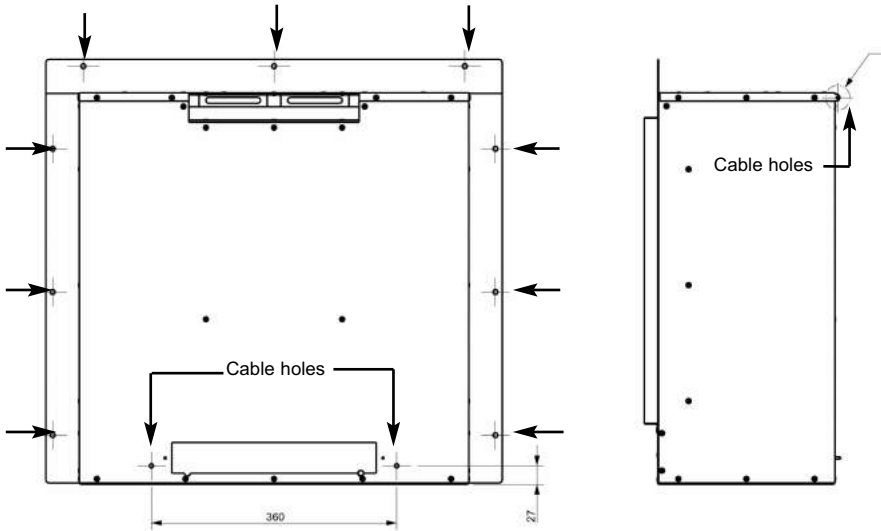

2.3 GAS TIGHTNESS AND INLET PRESSURE

- 2.3.1 Remove the pressure test point screw from the inlet elbow and fit a manometer.
- 2.3.2 Turn on the main gas supply and carry out a gas tightness test.
- 2.3.3 See section 3.2 for full details of the operating method for the fire. The fire will then commence its ignition sequence and will light to high.
- 2.3.4 Check that the gas pressure is **20.0 mbar (+/- 1.0mbar) 8.0 in w.g.(+/- 0.4 in w.g.)**
- 2.3.5 Turn off the fire, remove the manometer and refit the pressure test point screw. Check the pressure test point screw for gas tightness with the appliance turned on using a suitable leak detection fluid or detector.

PLEASE NOTE - THE WORKING PRESSURE TEST ON THIS PRODUCT NEEDS TO BE COMPLETED BEFORE THE FUEL-BED IS FITTED.

2.4 INSTALLING THE “RENNES” SURROUND

- 2.4.1 Unpack the surround from the wooden crate, check all parts are present as per figure 15 overpage and carefully store the components.
- 2.4.2 The underside of the hearth should be painted with a weak PVA (8 parts water to 1 part PVA). This will prevent staining penetrating through the stone. The hearth must be centered to the opening. If the fireplace is to be installed on a chimney breast ensure that the opening is also centered to the chimney breast. It is essential that the hearth is completely level. The hearth must be bedded down on bonding or an equivalent material. Avoid cement based products and ensure the hearth is firmly fitted and well supported. Allow the bedding material to set before any weight is placed onto the hearth. Wipe off any surplus bonding material with a wet sponge.
- 2.4.3 Fit bottom section to hearth, ensure it is central before fixing with a suitable mastic adhesive.
- 2.4.4 Fit brackets to top of legs, offer leg up to wall and mark position of fixing hole on wall, use shelf to ensure legs are correctly spaced / positioned. Remove shelf then cover hearth with dust sheet and drill the fixing holes. Remove the brackets from the legs, fix the side infills into place with suitable adhesive and secure the leg fixing brackets only to the wall. Fit legs to brackets that have been securely attached to the wall with fixings as detailed in 2.4.5
- 2.4.5 Assess the chimney breast onto which the fire is to be installed and ensure that it is of sound construction and suitable for supporting the weight of the surround. Fixings used to secure the leg brackets to the masonry of the chimney breast shall be of expansive stainless steel or galvanised steel type masonry fixings for dense concrete blockwork or brickwork. Where fixings are located into light weight blockwork or friable aggregate blocks, the fixings shall be of the resin anchor type.**
- 2.4.6 Fix the top infill and shelf infill into place again with suitable mastic adhesive.
- 2.4.7 Fit shelf into place ensuring it is correctly aligned with legs, mark the position of holes for securing brackets on wall, remove shelf and drill wall and insert fixings in accordance with 2.4.5, these brackets can be recessed if required.
- 2.4.8 Once the fireplace is correctly installed, grout all of the joints including between the fireplace and the wall with a water based cream mastic or tile grout. Ensure all surplus grout is immediately removed by washing the stonework using a sponge and clean water.

Fig. 15 - "Rennes" Surround

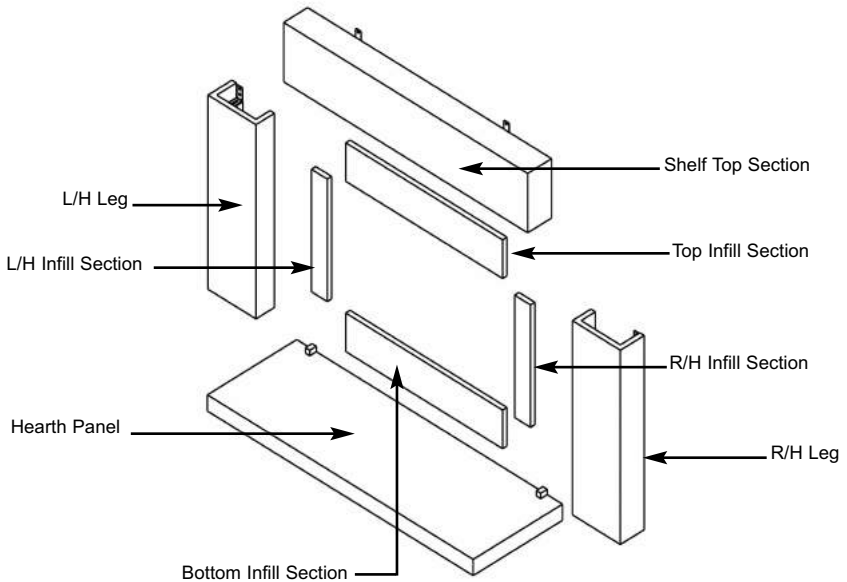

Contents of Rennes surround :-

- 1 off hearth panel
- 1 off R/H leg
- 1 off L/H leg
- 1 off R/H infill section
- 1 off L/H infill section
- 1 off bottom infill section
- 1 off shelf

NOTE : It is recommended that a spillage test is completed before fixing / sealing the fire surround in place.

2.5 INSTALLING THE “AVIGNON” SURROUND

2.5.1 Unpack the surround from the wooden crate, check all parts are present as per figure 16 overpage and carefully store the components.

2.5.2 The underside of the hearth should be painted with a weak PVA (8 parts water to 1 part PVA). This will prevent staining penetrating through the stone. The hearth must be centered to the opening. If the fireplace is to be installed on a chimney breast ensure that the opening is also centered to the chimney breast. It is essential that the hearth is completely level. The hearth must be bedded down on bonding or an equivalent material. Avoid cement based products and ensure the hearth is firmly fitted and well supported. Allow the bedding material to set before any weight is placed onto the hearth. Wipe off any surplus bonding material with a wet sponge.

2.5.3 Fit bottom section to hearth, ensure it is central before fixing with a suitable mastic adhesive.

2.5.4 Fit brackets to top of legs, offer leg up to wall and mark position of fixing hole on wall, use shelf to ensure legs are correctly spaced / positioned. Remove shelf then cover hearth with dust sheet and drill the fixing holes. Remove the brackets from the legs, fix the side infills into place with suitable adhesive and secure the leg fixing brackets only to the wall. Fit legs to brackets that have been securely attached to the wall with fixings as detailed in 2.5.5

2.5.5 Assess the chimney breast onto which the fire is to be installed and ensure that it is of sound construction and suitable for supporting the weight of the surround. Fixings used to secure the leg brackets to the masonry of the chimney breast shall be of expansive stainless steel or galvanised steel type masonry fixings for dense concrete blockwork or brickwork. Where fixings are located into light weight blockwork or friable aggregate blocks, the fixings shall be of the resin anchor type.

2.5.6 Fix the shelf top infill section and shelf infill into place again utilising the same procedure as for the legs, i.e. mark positions, drill holes to suit, remove brackets and secure brackets to wall with suitable fixings as detailed in 2.5.5

2.5.7 Fit shelf top section into place ensuring it is correctly centered, mark the position of holes for securing brackets on wall, remove shelf and drill wall and insert fixings in accordance with 2.5.5, these brackets can be recessed if required.

2.5.8 Once the fireplace is correctly installed, grout all of the joints including between the fireplace and the wall with a water based cream mastic or tile grout. Ensure all surplus grout is immediately removed by washing the stonework using a sponge and clean water.

Fig. 16 - "Avignon" Surround

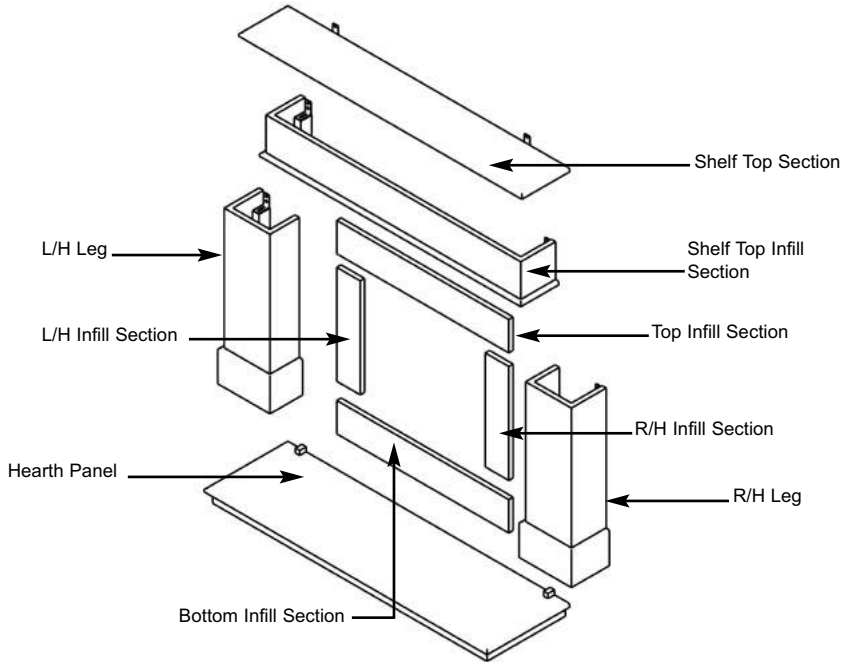

Contents of Avignon surround :-

- 1 off hearth panel
- 1 off R/H leg
- 1 off L/H leg
- 1 off R/H infill section
- 1 off L/H infill section
- 1 off bottom infill section
- 1 off shelf top infill section
- 1 off shelf top section
- 1 off top infill section

NOTE : It is recommended that a spillage test is completed before fixing / sealing the fire surround in place.

2.6 INSTALLING THE “ETIENNE” SURROUND

2.6.1 Unpack the surround from the wooden crate, check all parts are present as per figure 17 overpage and carefully store the components.

2.6.2 The underside of the hearth should be painted with a weak PVA (8 parts water to 1 part PVA). This will prevent staining penetrating through the stone. The hearth must be centered to the opening. If the fireplace is to be installed on a chimney breast ensure that the opening is also centered to the chimney breast. It is essential that the hearth is completely level. The hearth must be bedded down on bonding or an equivalent material. Avoid cement based products and ensure the hearth is firmly fitted and well supported. Allow the bedding material to set before any weight is placed onto the hearth. Wipe off any surplus bonding material with a wet sponge.

2.6.3 Fit bottom section to hearth, ensure it is central before fixing with a suitable mastic adhesive.

2.6.4 Fit brackets to top of legs, offer leg up to wall and mark position of fixing hole on wall, use shelf to ensure legs are correctly spaced / positioned. Remove shelf then cover hearth with dust sheet and drill the fixing holes. Remove the brackets from the legs, fix the side infills into place with suitable adhesive and secure the leg fixing brackets only to the wall. Fit legs to brackets that have been securely attached to the wall with fixings as detailed in 2.6.5

2.6.5 Assess the chimney breast onto which the fire is to be installed and ensure that it is of sound construction and suitable for supporting the weight of the surround. Fixings used to secure the leg brackets to the masonry of the chimney breast shall be of expansive stainless steel or galvanised steel type masonry fixings for dense concrete blockwork or brickwork. Where fixings are located into light weight blockwork or friable aggregate blocks, the fixings shall be of the resin anchor type.

2.6.6 Fix the shelf top infill section and shelf infill into place again utilising the same procedure as for the legs, i.e. mark positions, drill holes to suit, remove brackets and secure brackets to wall with suitable fixings as detailed in 2.6.5

2.6.7 Fit shelf top section into place ensuring it is correctly centered, mark the position of holes for securing brackets on wall, remove shelf and drill wall and insert fixings in accordance with 2.6.5, these brackets can be recessed if required.

2.6.8 Once the fireplace is correctly installed, grout all of the joints including between the fireplace and the wall with a water based cream mastic or tile grout. Ensure all surplus grout is immediately removed by washing the stonework using a sponge and clean water.

Fig. 17 - "Etienne" Surround

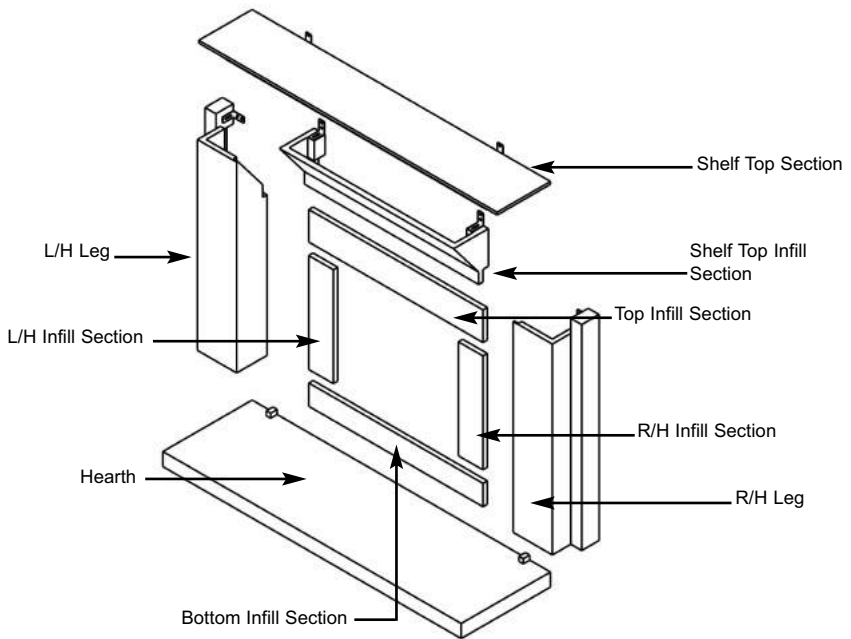

Contents of Etienne surround :-

- 1 off hearth panel
- 1 off R/H leg
- 1 off L/H leg
- 1 off R/H infill section
- 1 off L/H infill section
- 1 off bottom infill section
- 1 off shelf top infill section
- 1 off shelf top section
- 1 off top infill section

NOTE : It is recommended that a spillage test is completed before fixing / sealing the fire surround in place.

2.7 CHECKING MECHANICAL FIXING OF SURROUND COMPONENTS

2.7.1 Ensure that the surround components as shown below are mechanically secured as indicated, this is required in accordance with the latest revision of *BS 1251 : 2015 Open Fireplace Components*.

Fig. 18 - "Rennes" Surround

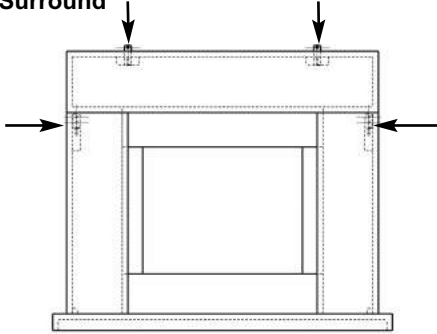

Fig. 19 - "Avignon" Surround

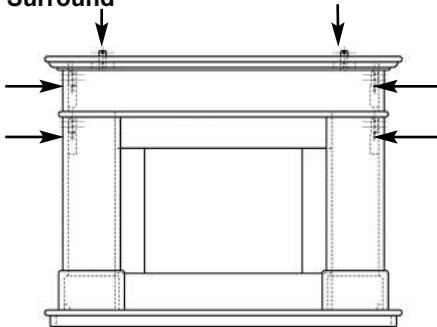
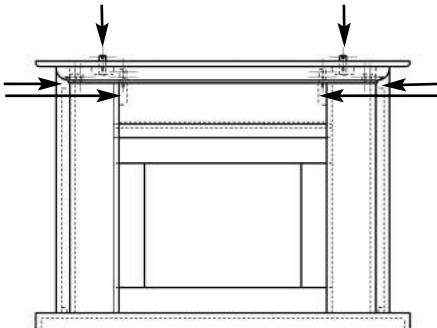

Fig. 20 - "Etienne" Surround



3.1 FITTING THE FUEL-BED LOGSET

- 3.1.1 Place the L/H and R/H ceramic base pieces onto the ceramic support panel as shown below in figure 21.

Fig. 21

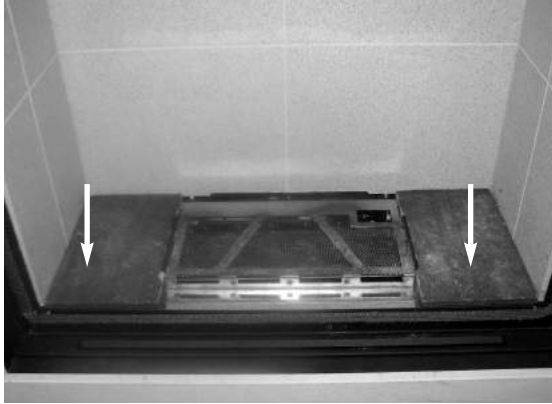

- 3.1.2 Place the front ceramic base piece onto the ceramic support as shown below in figure 22.

Fig. 22



- 3.1.3 Place the base log onto the ceramic support panel as shown below in figure 23, ensuring the spacer locating blocks on the rear face are fitted flush up against the rear panel.

Fig. 23

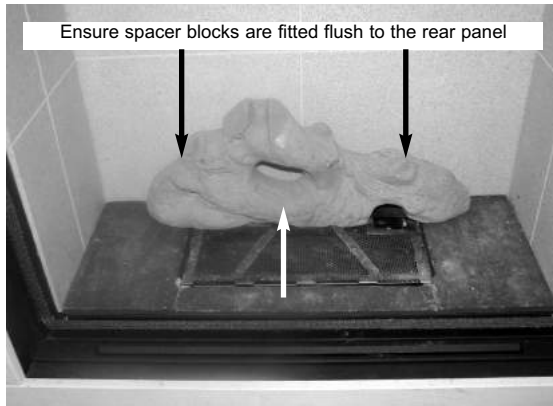

- 3.1.4 Cover the burner and fuel-bed base ceramic in a single, even layer of bark chippings as shown below in figure 24.

Fig. 24



3.1.5 Position log “H” onto the base log using the location lug on the back face of log “H” and the groove on the base log to find the correct location, as shown below in figure 25.

Fig. 25

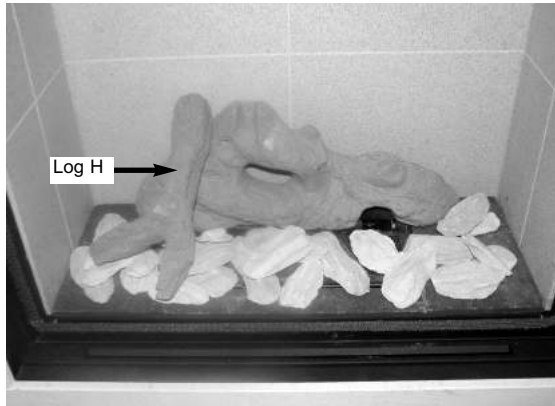

3.1.6 Position log “E” onto the base log using the location lug on the back face of log “E” and the groove on the base log to find the correct location as shown below in figure 26.

Fig. 26

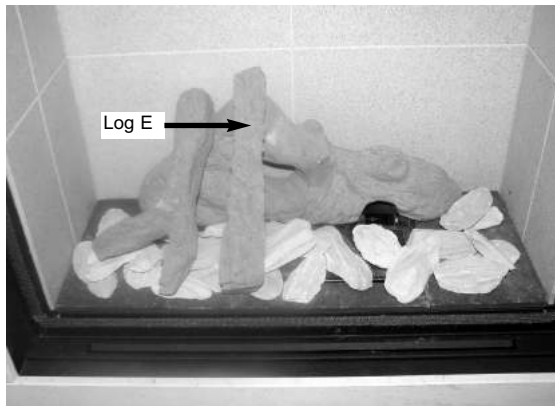

3.1.7 Position log “B” onto the base log using the location lug on the back face of log “B” and the groove on the base log to find the correct location as shown below in figure 27.

Fig. 27

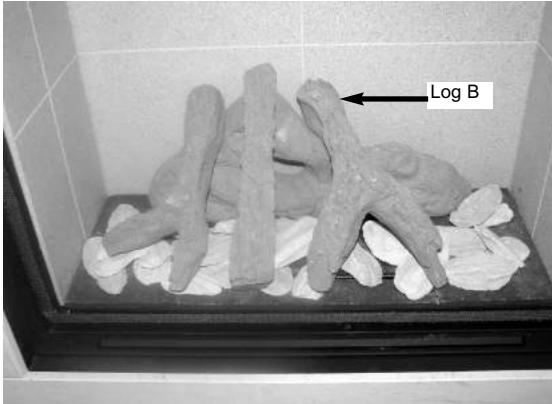

3.1.8 Position log “G” onto the base log using the location lug on the back face of log “G” and the groove on the base log to find the correct location as shown below in figure 28.

Fig. 28

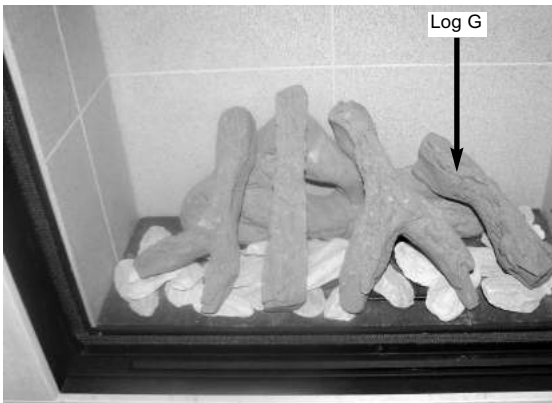

3.1.9 Re-fit the glass panel in reverse order to that shown in section 2.2.2.

Warning : Use only the logs supplied with the fire. When replacing the logs remove the old logs and discard them. Fit a complete set of logs of the correct type. Do not fit additional logs or any logs other than a genuine replacement set.

To ensure that the release of fibres from these R.C.F (Refractory Ceramic Fibre) articles is kept to a minimum, during installation and servicing we recommend that you use a HEPA filtered vacuum to remove any dust accumulated in and around the appliance before and after working on the appliance. When replacing these articles we recommend that the replaced items are not broken up, but are sealed within heavy duty polythene bags, clearly labelled as “RCF waste”. RCF waste is classed as a “stable”, non reactive hazardous waste and may be disposed of at a landfill licensed to accept such waste Protective clothing is not required when handling these articles, but we recommend you follow the normal hygiene rules of not smoking, eating or drinking in the work area, and always wash your hands before eating or drinking.

This appliance does not contain any component manufactured from asbestos or asbestos related products.

3.2 FITTING THE BATTERIES

3.2.1 The battery pack is located under the front grill as shown below in figure 29.

Fig. 29

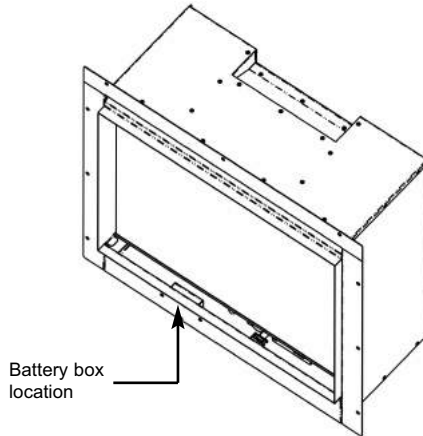

3.2.2 Lift battery pack from its retaining bracket, remove rear cover (held in position by screw) and then fit 3 off AA batteries. Replace cover and then re-position battery pack within retaining bracket.

3.2.3 Fit 2 off AA sized batteries to handset - removing rear cover, fit batteries and replace rear cover. Now proceed to section 3.3.1 and set the time, date and temperature on the remote control handset.

3.3 OPERATION OF THE FIRE

IMPORTANT : IF THE BURNER IS EXTINGUISHED FOR ANY REASON YOU MUST ENSURE THAT YOU WAIT A FULL FIVE MINUTES BEFORE ATTEMPTING TO RE-LIGHT THE FIRE.

The product is controlled by the remote handset supplied with the fire.

3.3.1 SETTING THE TIME, DATE & TEMPERATURE ON THE REMOTE HANDSET

- 3.3.1.1 Fit the 2 off AA batteries to the handset by removing the cover on the rear of the handset and inserting the batteries, ensure the correct +/- polarity is observed. Following insertion of the batteries the screen displayed will be as shown below in figure 30.

Fig. 30



- 3.3.1.2 Hold the handset with one hand ensuring your hand is wrapped around the back and that your hand is in contact with both sides of the handset. The green light of the “unlock” symbol should light and the screen displayed will be as shown overpage in figure 31.
- 3.3.1.3 The “H” symbol as indicated in figure 31 overpage indicates that the timer can now be set in either 24hr or 12hr mode. Press the + or - buttons on the handset to toggle between the two settings, figure 31 overpage displays the 24hr mode.

Fig. 31



3.3.1.4 When the 24hr or 12hr time display option has been chosen and you are ready to confirm the setting you want press the SET button on the handset to progress to setting the day of the week as shown overpage in figure 32..

3.3.1.5 Press and release the + and - buttons on the handset until the correct day of the week is shown on the handset display

- Mo = Monday
- Tu = Tuesday
- We = Wednesday
- Th = Thursday
- Fr = Friday
- Sa = Saturday
- Su = Sunday

3.3.1.6 Press SET to accept the day of the week and progress to setting the hour of the day.

Fig. 32

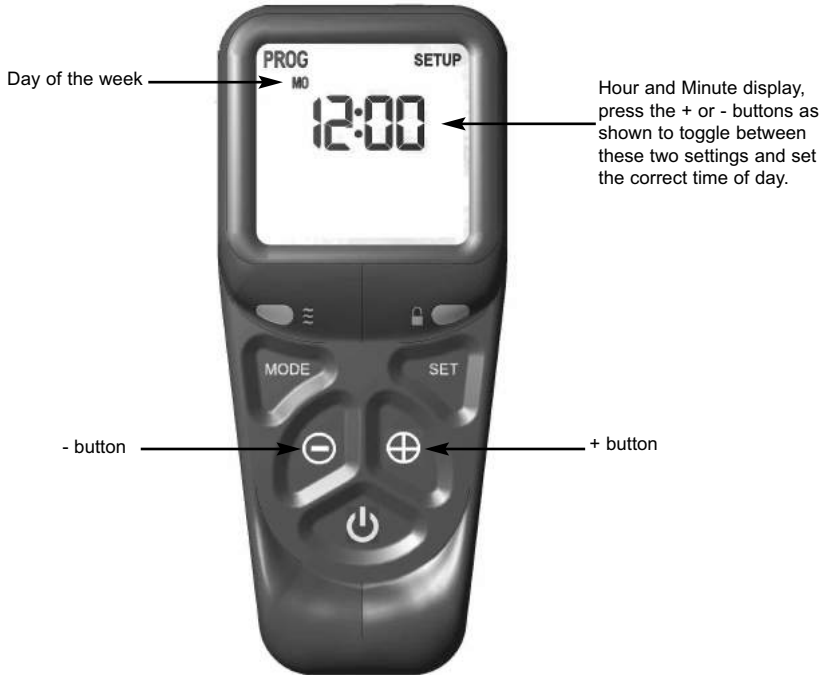

3.3.1.7 As shown above in figure 32 the time on the handset can now be set by using the + and - buttons to change the hour to the correct hour then press SET to store and to move to setting the minute. Repeat this process for setting the minute to the correct minute then press SET to store.

3.3.1.8 The handset will then display the temperature setting screen as shown overpage in figure 33, the option to choose either Celsius or Fahrenheit can be chosen, these settings are shown as either C or F. Use the + and - buttons to toggle between these two options then press SET to store. The important settings have now been completed so press and hold the SET button for a few seconds and this will exit the set-up menu.

Fig. 33



3.3.1.9 The control is now ready for use with the burner.

3.3.1.10 If the handset is misplaced you can “page it” by pressing the (+) button only on the control valve on the fire for a period of 5 seconds. The handset will flash and make an audible noise to help you locate it. Once you find the handset with one hand ensure your hand is wrapped around the back and that your hand is in contact with both sides of the handset then the audible noise will cease. The flashing and sound will last for 60 seconds each time the handset is paged as described. If not found in 60 seconds page the handset again until located.

3.4 LIGHTING THE FIRE - REMOTE CONTROL MODELS

3.4.1 Ensure valve power isolation switch is in the on position - see figure 34 and that the time, date & temperature display settings as shown in section 3.3 have been completed. Hold the handset with one hand ensuring your hand is wrapped around the back and that your hand is in contact with both sides of the handset. The green light of the “unlock” symbol should light. See figure 34 below.

Fig. 34

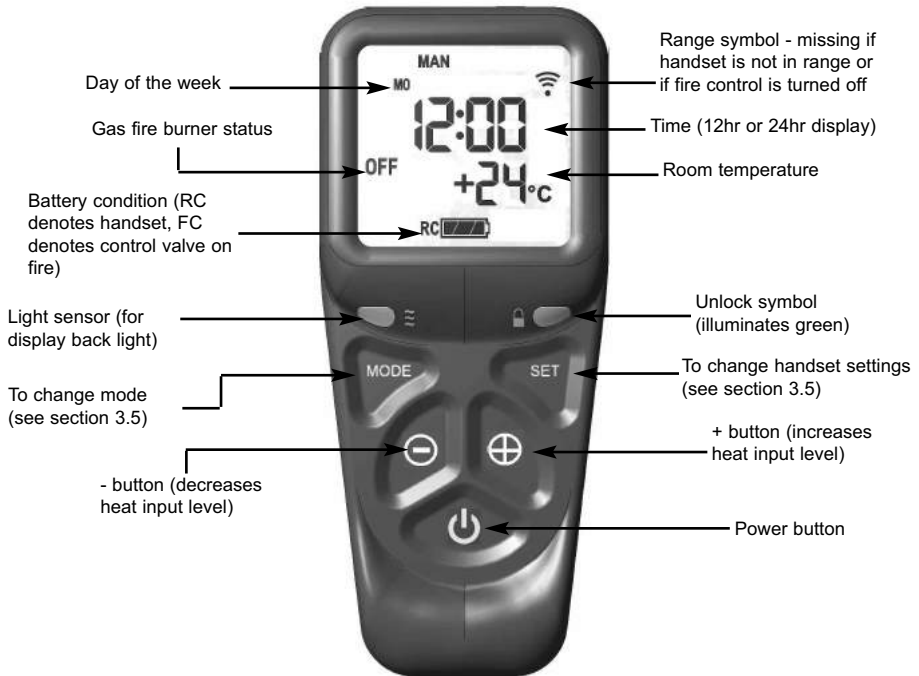

3.4.2 Press and hold the power button continuously until the word “PILOT” appears at the bottom left of the display as shown overpage in figure 14, (this typically takes two seconds). The burner will now light at maximum heat input level and will display “MAX” in the bottom left hand side of the display as shown in figure 35 overpage.

NOTE : If the power button is pressed for too long or too short a time or the grip on the handset is not firm or is released too soon, the lighting sequence will be interrupted and not complete. The reason for the remote control having this strict start sequence is for safety reasons so that the starting operation of the fire will be most unlikely to be done other than intentionally by an adult.

Fig. 35 - "PILOT" displayed



"PILOT" displayed on handset during ignition sequence (typically takes two seconds)

Fig. 36 - "MAX" & large flame symbol displayed

"MAX FLAME" displayed on handset when burner is lit to maximum rate



3.4 LIGHTING THE APPLIANCE - REMOTE CONTROL MODELS (CONTINUED)

3.4.3 To decrease the heat input level of the burner hold the handset as described in section 3.4.1 to unlock the keypad then press and release the - button. Pressing and releasing the - button will lower the heat input level one step at a time. Pressing the - button continuously will move the heat input level to the minimum, see figure 37 below.

Fig. 37



3.4.4 To increase the heat input level of the fire's burner hold the handset as described in section 3.4.1 to unlock the keypad then press and release the + button. Pressing and releasing the + button will increase the heat input level one step at a time. Pressing the + button continuously will move the heat input level to the maximum.

3.4.5 To turn the fire off hold the handset as described in section 3.4.1 to unlock the keypad then press and release the power button. The burner will go out.

3.4.6

If you are not intending to use the fire for a long period (i.e. over the summer months) the battery life can be extended by disconnecting the battery pack from the valve, see section 2.2.1

3.4.7

In the event of loss of the remote handset, as a backup the fire can be turned off by pressing the on/off switch located below the grill at the base of the fire.

3.4.8

If the handset is misplaced you can “page it” by pressing the (+) button only on the control valve on the fire for a period of 5 seconds. The handset will flash and make an audible noise to help you locate it. Once you find the handset with one hand ensure your hand is wrapped around the back and that your hand is in contact with both sides of the handset then the audible noise will cease. The flashing and sound will last for 60 seconds each time the handset is paged as described. If not found in 60 seconds page the handset again until located.

3.5

ADVANCED SETTINGS MENU OF THE REMOTE CONTROL

3.5.1

Snooze mode in manual operation

3.5.1.1

Snooze mode is a time period which can be set which will turn the fire automatically off after a certain time period has elapsed.

3.5.1.2

Hold the handset with one hand ensuring your hand is wrapped around the back and that your hand is in contact with both sides of the handset. The green light of the “unlock” symbol should light. The snooze time period can be set either before or during manual operation of the fire.

3.5.1.3

With the handset held as described above, press the mode button to scroll through the functions until the symbols MAN and Zzz are flashing at the top of the display as shown overpage in figure 38.

3.5.1.4

Press and release the set button and this will put the control into the manual snooze mode.

3.5.1.5

The default time period in snooze mode is 1:00 hour.

Fig. 38



3.5.1.6 Pressing the set button again will now show you the snooze time period remaining. The snooze time period can be adjusted by pressing the + or - buttons on the handset. This time period can be set ranging from 1 minute to 4:00 hours.

3.5.1.7 To adjust the snooze period, hold the handset with one hand ensuring your hand is wrapped around the back and that your hand is in contact with both sides of the handset. The green light of the “unlock” symbol should light. Press the set button and the screen will show how long is left of the snooze period as shown overpage in figure 39.

Fig. 39



- 3.5.1.8 To adjust the snooze period use the + and - buttons to increase or decrease the snooze period for any period between 1 minute and 4:00 hours.
- 3.5.1.9 When the correct snooze period is indicated on the handset, press the set button to store the required time period, or alternatively the handset can be left for a few seconds and the period will be stored automatically.
- 3.5.1.10 When the countdown timer for the snooze period has reached zero the fire will turn off (as if you had turned the fire off manually).

3.5.2 Thermostatic mode

PLEASE NOTE : Thermostatic mode of this fire will only allow regulation of the room temperature by the fire when it has been already lit via manual operation of the handset. It will not allow the fire to light automatically due to low ambient room temperature and should therefore not be relied upon for frost protection purposes.

3.5.2.1 Hold the handset with one hand ensuring your hand is wrapped around the back and that your hand is in contact with both sides of the handset. The green light of the “unlock” symbol should light.

3.5.2.2 With the handset held as described above, press and release the mode button several times as necessary until the display has the thermometer symbol flashing at the top of the display. Press the set button to enter this mode, as shown below in figure 40.

Fig. 40



3.5.2.3 Press the set button again to see the temperature setting that is set (the default is 24 degrees celsius). If a different set temperature is required, whilst the display is showing this set temperature, press the + and - buttons to alter this setting, press the set button to store the required temperature, or alternatively the handset can be left for a few seconds and the temperature will be stored automatically.

3.5.2.4 If at any time the power button is operated during thermostat mode the control will cancel any thermostat operation and return the control to manual mode.

3.5.2.5 **IMPORTANT NOTE : Thermostat mode will not light the fire automatically and will only regulate between the maximum and minimum burner setting. The fire must be lit manually via the handset and then you enter thermostat mode as described in this section and set the temperature. When no longer requiring thermostat mode turn off the burner and the handset will return to manual mode.**

3.6 CHECKING FOR CLEARANCE OF COMBUSTION PRODUCTS

- 3.6.1 Close all doors and windows in the room.
- 3.6.2 Light the fire and allow to run for approximately 5 minutes on high position.
- 3.6.3 After approximately 5 minutes hold a smoke match just inside and below the centre of the lower front edge of the top of the fire, as shown below in figure 41. (It is recommended that a suitable smoke match holder is used when checking for clearance of combustion products). All smoke generated should be drawn back into the flue. If slight spillage occurs or if in doubt, repeat the test after a further 5-10 minutes. **If the test indicates that spillage is occurring and the flue restrictor baffle has been fitted, it should be removed as shown in section 3.4 and the test repeated after the fire has cooled.**
- 3.6.4 If spillage persists, the flue is not functioning correctly and a fault exists. If, after investigation the fault cannot be traced and rectified, the fire must be disconnected from the gas supply and expert advice obtained.
- 3.6.5 If there is an extractor fan fitted any where in the vicinity of the appliance, or in adjacent rooms the spillage test should be repeated with the fan running on maximum and all interconnecting doors open.
- 3.6.6 After ensuring that the fire is safe to use it should be left on high position to fully warm up. During this time a slight odour may be noticed, this is due to the “newness” of the fire and will soon disappear.

Fig. 41

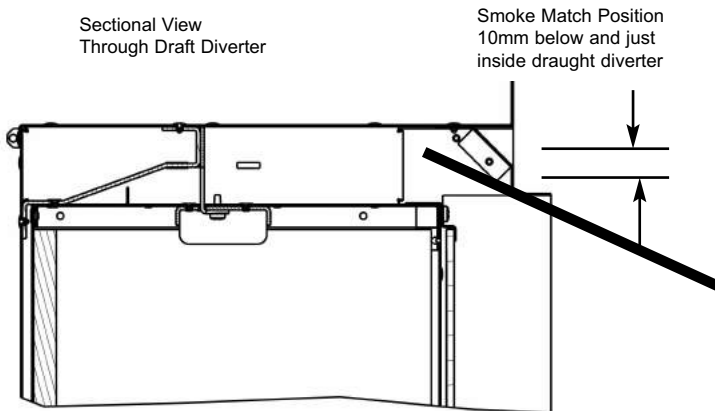

3.7 REMOVING / RE-FITTING THE FLUE RESTRICTOR BAFFLE

- 3.7.1 The restrictor baffle is secured with 2 off screws to the internal roof of the combustion chamber.
- 3.7.2 Remove the glass panel as detailed in section 2.2 and unscrew or re-fit the baffle from the internal roof of the combustion chamber as shown below in figure 42.

Fig. 42

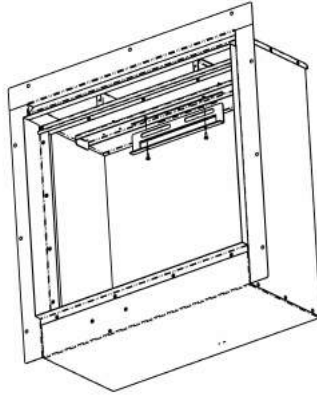

- 3.7.3 Re-check the spillage test as required.

3.8 FITTING THE OPTIONAL TRIM

- 3.8.1 The trim assembly fits to the firebox flange as shown below in figure 43.

Fig. 43

Trim assembly fitted to fire, magnets are fitted to brackets as indicated

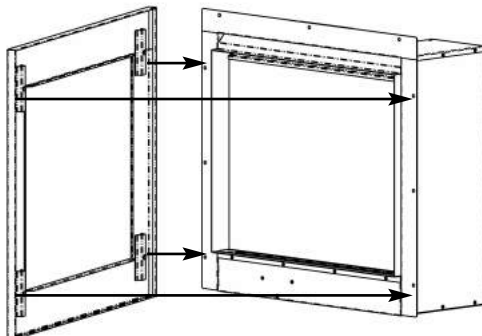

SECTION 4 MAINTENANCE

Servicing Notes

Servicing should be carried out annually by a competent person such as a GAS SAFE registered engineer. **This is a condition of the guarantee schemes.** The service should include visually checking the chimney and fire opening for accumulations of debris and a smoke test to check for a positive up-draught in the chimney. To access the debris collection void a removeable plate is positioned on the rear face of the firebox box behind the burner. The oxypilot on the burner unit must also be changed as a condition of the guarantee. The condition of the fuel-bed should be checked and **if necessary the whole item should be replaced with a genuine replacement item.** The burner assembly is designed to be removed as a complete unit for ease of access. **After any servicing work a gas tightness check must always be carried out.**

For Diagrams refer to Section 2

4.1 Removing the burner assembly from the fire.

4.1.1 Prepare work area (lay down dust sheets etc.)

4.1.2 Remove the glass assembly, remove the ceramic logs.

4.1.3 Isolate the gas supply and remove the supply pipe from the appliance inlet elbow. Unscrew and remove the four off screws which retain the ceramic support plate to the base, then lift clear. Remove the four off screws which hold the burner in position & then loosen injector screw, then remove four screws from burner base plate then remove burner assembly from the fire.

4.1.4 To refit the burner assembly, locate the burner unit and refit the four off screws. Refit the ceramic support plate and four off screws. Refit the gas supply pipe and carry out a gas tightness test. Refit the fuel-bed referring to section 3 for the correct log positions. Re-fit the glass panel.

4.2 Removing the Gas Control Valve

4.2.1 Remove the burner assembly as detailed in section 4.1,

4.2.2 Remove the thermocouple wires from the valve, remove the main pipe, inlet pipe, pilot pipe from the valve. Take note of position of coloured terminals on thermocouple wires as valve will not function correctly if these are replaced the opposite way round.

4.2.3 Unclip the valve from its mounting bracket. Re-assemble in reverse order and carry out a gas tightness test.

4.3 Removing the Oxy-Pilot.

Note : Because this appliance is fitted with an atmosphere sensing 'Oxy-Pilot' it is not possible to replace the thermocouple separately, because the thermocouple position is factory set to a tight tolerance. Any replacement of parts on the pilot requires a complete new pilot assembly.

4.3.1 Prepare work area (lay down dust sheets etc.)

4.3.2 Remove the glass panel as shown in section 2.2 and put it in a safe location, remove burner assembly as per section 4.1

4.3.3 Loosen the pilot nut and remove the two screws retaining the pilot assembly. Remove wires from the valve

4.3.4 Re-assemble in reverse order and carry out a gas tightness test.

4.4 Replacing the Batteries in the Handset.

4.4.1 Remove and re-fit the new 2 off AA batteries by removing the cover on the back of the handset.

4.5 Replacing the Batteries in the Fire

4.5.1 The battery pack is located as shown below in figure 44.

Fig. 44

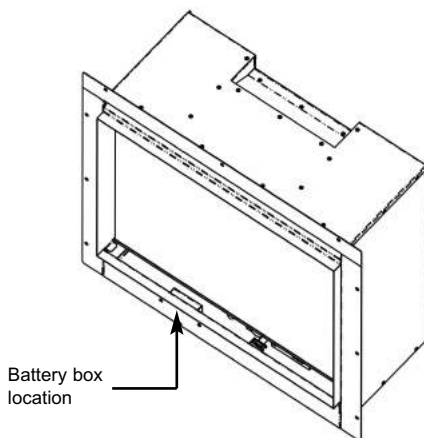

4.5.2 Lift battery pack from its retaining bracket, remove rear cover (held in position by screw) and then fit 3 off AA batteries. Replace cover and then re-position battery pack within retaining bracket.

4.6 Checking for Flue Debris.

4.6.1 Remove the burner assembly as detailed in section 4.1

4.6.2 Locate the removeable backplate on the rear face of the firebox at the bottom.

4.6.3 Remove the 2 screws that hold the removeable backplate on the rear face of the firebox.

4.6.4 Remove any debris.

4.6.5 Replace the removeable backplate on the rear face of the firebox.

4.7 SPARE PARTS LIST

B-160780	RC gas control valve
B-168970	RC handset
B-181610	On/Off override switch
B-34690	Ignition cable
B-180090	ERTA PG-82-330 ODS pilot assy
B-65480	Main burner injector Cat 82 size 360
B-178790	Glass panel
B-179240	Complete log set
B-182650	Rear log only
B-182660	Log "B" only
B-182670	Log "E" only
B-182680	Log "G" only
B-182690	Log "H" only
B-179220	Fuel-bed base front
B-179230	Fuel-bed base side
B-182640	Spare bag of bark chippings

SECTION FIVE - USER INSTRUCTIONS

5.1 INSTALLATION INFORMATION

CONDITIONS OF INSTALLATION

It is the law that all gas appliances are installed only by a competent (e.g. Registered) Installer, in accordance with the installation instructions and the Gas Safety (Installation and Use) Regulations 1998. Failure to install appliances correctly could lead to prosecution. It is in your own interest and that of safety to comply with the law.

The fire may be fitted below a combustible shelf provided that the shelf is at least 200mm above the top of the appliance and the depth of the shelf does not exceed 150mm.

The fire may be installed below combustible shelves which exceed 150mm deep providing that the clearance above the fire is increased by 15mm for each 25mm of additional overhang in excess of 150mm.

No purpose made additional ventilation is normally required for this appliance when installed in G.B. When installed I.E. please consult document I.S. 813 : 1996 Domestic Gas Installation which is issued by the National Standards Authority of Ireland. Any purpose made ventilation should be checked periodically to ensure that it is free from obstruction.

If the chimney or flue has been previously used by appliances burning fuels other than gas they must be swept prior to the installation of this fire.

If this appliance is fitted directly on to a wall without the use of a fireplace or surround, soft wall coverings such as wallpaper, blown vinyl etc. could be affected by the heat and hot convection air and may discolour or scorch. This should be considered when installing or decorating.

The Model number of this appliance is as stated on the rating plate affixed to the control panel of the fire and the appliance is manufactured by:-

BFM Europe Ltd
Trentham Lakes
Stoke on Trent
ST4 4TJ

5.2 ABOUT YOUR NEW CELENA GAS FIRE

The BFM Fires “Celena” log effect gas fire incorporates a unique and highly developed fuel bed which gives the realism of a loose log layout combined with realistic flames and glow. The use of durable ceramic material in the construction of the fuelbed components ensures long and trouble free operation.

Please take the time to fully read these instructions as you will then be able to obtain the most effective and safe operation of your fire.

IMPORTANT SAFETY INFORMATION

WARNING

This appliance is a heating appliance and as with all heating appliances a fireguard should be used for the protection of children, the elderly and infirm. Fireguards should conform to B.S. 8423 : 2002 (Fireguards for use with gas heating appliances).

It is important that this appliance is serviced at least once a year by a GAS SAFE registered engineer. During the annual service, replacement of the pilot must be carried out. **This is a condition of the manufacturers guarantee.** Any debris or deposits should be removed from the fuel bed from time to time. This may be carried out by referring to the cleaning section as described later in this book. Only the correct number and type of logs must be used and only complete and genuine replacement sets must be used. Always keep furniture and combustible materials well clear of the fire and never dry clothing or items either on or near to the fire. Never use aerosols or flammable cleaning products near to the fire when it is in use.

The ceramic fuel bed remains hot for a considerable period after use and sufficient time should be allowed for the fire to cool before cleaning etc.

IMPORTANT : DO NOT UNDER ANY CIRCUMSTANCES USE THIS FIRE IF THE GLASS PANEL IS BROKEN, CRACKED OR MISSING.

IMPORTANT : THIS APPLIANCE IS NOT INTENDED FOR USE BY PERSONS (INCLUDING CHILDREN) WITH REDUCED PHYSICAL, SENSORY OR MENTAL CAPABILITIES, OR LACK OF EXPERIENCE AND KNOWLEDGE, UNLESS THEY HAVE BEEN GIVEN SUPERVISION OR INSTRUCTION CONCERNING USE OF THE APPLIANCE BY A PERSON RESPONSIBLE FOR THEIR SAFETY. CHILDREN SHOULD BE SUPERVISED TO ENSURE THAT THEY DO NOT PLAY WITH THE APPLIANCE. ANY

5.3 OPERATING THE FIRE AND USER CONTROLS

- 5.3.1 Ensure valve power isolation switch is in the on position - see figure 6
Hold the handset with one hand ensuring your hand is wrapped around the back and that your hand is in contact with both sides of the handset.
The green light of the “unlock” symbol should light. See figure 1 below.

Fig. 1

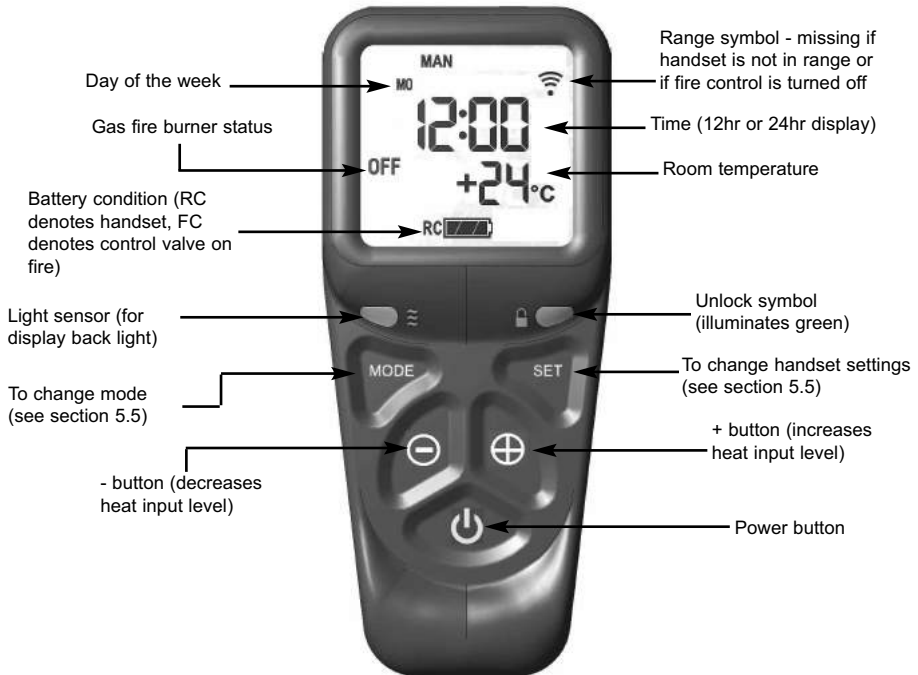

- 5.3.2 Press and hold the power button continuously until the word “PILOT” appears at the bottom left of the display as shown overpage in figure 2, (this typically takes two seconds). The burner will now light at maximum heat input level and will display “MAX” in the bottom left hand side of the display as shown in figure 3 overpage. **For most efficient performance leave the fire on high when lighting from cold for ten minutes.**

NOTE : If the power button is pressed for too long or too short a time or the grip on the handset is not firm or is released too soon, the lighting sequence will be interrupted and not complete. The reason for the remote control having this strict start sequence is for safety reasons so that the starting operation of the fire will be most unlikely to be done other than intentionally by an adult.

Fig. 2 - "PILOT" displayed



"PILOT" displayed on handset during ignition sequence (typically takes two seconds)

Fig. 3 - "MAX" & large flame symbol displayed

"MAX FLAME" displayed on handset when burner is lit to maximum rate



5.3 OPERATING THE FIRE AND USER CONTROLS (CONTINUED)

- 5.3.3 To decrease the heat input level of the burner hold the handset as described in section 5.3.1 to unlock the keypad then press and release the - button. Pressing and releasing the - button will lower the heat input level one step at a time. Pressing the - button continuously will move the heat input level to the minimum, see figure 4 below.

Fig. 4



- 5.3.4 To increase the heat input level of the fire's burner hold the handset as described in section 5.3.1 to unlock the keypad then press and release the + button. Pressing and releasing the + button will increase the heat input level one step at a time. Pressing the + button continuously will move the heat input level to the maximum.
- 5.3.5 To turn the fire off hold the handset as described in section 5.3.1 to unlock the keypad then press and release the power button. The burner will go out.

5.3.6

If you are not intending to use the fire for a long period (i.e. over the summer months) the battery life can be extended by disconnecting the battery pack from the valve, see section 2.2.1

5.3.7

In the event of loss of the remote handset, as a backup the fire can be turned off by pressing the on/off switch located below the grill at the base of the fire.

5.3.8

If the handset is misplaced you can “page it” by pressing the (+) button only on the control valve on the fire for a period of 5 seconds. The handset will flash and make an audible noise to help you locate it. Once you find the handset with one hand ensure your hand is wrapped around the back and that your hand is in contact with both sides of the handset then the audible noise will cease. The flashing and sound will last for 60 seconds each time the handset is paged as described. If not found in 60 seconds page the handset again until located.

IMPORTANT NOTE : THE BATTERIES SHOULD BE REPLACED WITH GOOD QUALITY ALKALINE BATTERIES WHEN REQUIRED, THE BATTERY LIFE IS EXPECTED TO BE A MINIMUM OF 12 MONTHS WITH NORMAL USAGE. FOR BEST PERFORMANCE BFM EUROPE RECOMMEND THE USE OF ENERGIZER BATTERIES WITH IT'S PRODUCTS.

5.4.1 Changing the batteries in the handset

- 5.4.1.1 Remove and re-fit the new 2 off AA batteries by removing the cover on the back of the handset.

5.4.2 Changing the batteries in the fire

- 5.4.2.1 The battery pack is located as shown below in figure 5.

Fig. 5

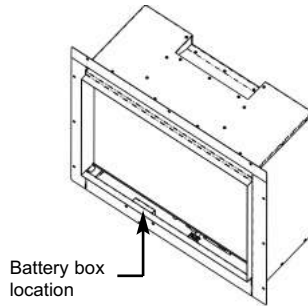

- 5.4.2.2 Lift battery pack from its retaining bracket, remove rear cover (held in position by screw) and then fit 3 off AA batteries. Replace cover and then re-position battery pack within retaining bracket.

5.5 SETTING THE TIME, DATE & TEMPERATURE ON THE REMOTE HANDSET

- 5.5.1 Fit the 2 off AA batteries to the handset by removing the cover on the rear of the handset and inserting the batteries, ensure the correct +/- polarity is observed. Following insertion of the batteries the screen displayed will be as shown below in figure 6.

Fig. 6



- 5.5.2 Hold the handset with one hand ensuring your hand is wrapped around the back and that your hand is in contact with both sides of the handset. The green light of the “unlock” symbol should light and the screen displayed will be as shown overpage in figure 7.
- 5.5.3 The “H” symbol as indicated in figure 7 overpage indicates that the timer can now be set in either 24hr or 12hr mode. Press the + or - buttons on the handset to toggle between the two settings, figure 7 overpage displays the 24hr mode.

Fig. 7



5.5.4 When the 24hr or 12hr time display option has been chosen and you are ready to confirm the setting you want press the SET button on the handset to progress to setting the day of the week as shown overpage in figure 8.

5.5.5 Press and release the + and - buttons on the handset until the correct day of the week is shown on the handset display

Mo = Monday
Tu = Tuesday
We = Wednesday
Th = Thursday
Fr = Friday
Sa = Saturday
Su = Sunday

5.5.6 Press SET to accept the day of the week and progress to setting the hour of the day.

Fig. 8



5.5.7 As shown above in figure 8 the time on the handset can now be set by using the + and - buttons to change the hour to the correct hour then press SET to store and to move to setting the minute. Repeat this process for setting the minute to the correct minute then press SET to store.

5.5.8 The handset will then display the temperature setting screen as shown overpage in figure 9, the option to choose either Celsius or Fahrenheit can be chosen, these settings are shown as either C or F. Use the + and - buttons to toggle between these two options then press SET to store. The important settings have now been completed so press and hold the SET button for a few seconds and this will exit the set-up menu.

Fig. 9



5.5.9 The control is now ready for use with the burner.

5.5.10 If the handset is misplaced you can “page it” by pressing the (+) button only on the control valve on the fire for a period of 5 seconds. The handset will flash and make an audible noise to help you locate it. Once you find the handset with one hand ensure your hand is wrapped around the back and that your hand is in contact with both sides of the handset then the audible noise will cease. The flashing and sound will last for 60 seconds each time the handset is paged as described. If not found in 60 seconds page the handset again until located.

5.6 ADVANCED SETTINGS MENU OF THE REMOTE CONTROL

5.6.1 Snooze mode in manual operation

- 5.6.1.1 Snooze mode is a time period which can be set which will turn the fire automatically off after a certain time period has elapsed.
- 5.6.1.2 Hold the handset with one hand ensuring your hand is wrapped around the back and that your hand is in contact with both sides of the handset. The green light of the “unlock” symbol should light. The snooze time period can be set either before or during manual operation of the fire.
- 5.6.1.3 With the handset held as described above, press the mode button to scroll through the functions until the symbols MAN and Zzz are flashing at the top of the display as shown below in figure 10.
- 5.6.1.4 Press and release the set button and this will put the control into the manual snooze mode.
- 5.6.1.5 The default time period in snooze mode is 1:00 hour.

Fig. 10



5.6.1.6 Pressing the set button again will now show you the snooze time period remaining. The snooze time period can be adjusted by pressing the + or - buttons on the handset. This time period can be set ranging from 1 minute to 4:00 hours.

5.6.1.7 To adjust the snooze period, hold the handset with one hand ensuring your hand is wrapped around the back and that your hand is in contact with both sides of the handset. The green light of the “unlock” symbol should light. Press the set button and the screen will show how long is left of the snooze period as shown below in figure 11.

Fig. 11



5.6.1.8 To adjust the snooze period use the + and - buttons to increase or decrease the snooze period for any period between 1 minute and 4:00 hours.

5.6.1.9 When the correct snooze period is indicated on the handset, press the set button to store the required time period, or alternatively the handset can be left for a few seconds and the period will be stored automatically.

5.6.1.10 When the countdown timer for the snooze period has reached zero the fire will turn off (as if you had turned the fire off manually).

5.6.2 Thermostatic mode

PLEASE NOTE : Thermostatic mode of this fire will only allow regulation of the room temperature by the fire when it has been already lit via manual operation of the handset. It will not allow the fire to light automatically due to low ambient room temperature and should therefore not be relied upon for frost protection purposes.

5.6.2.1 Hold the handset with one hand ensuring your hand is wrapped around the back and that your hand is in contact with both sides of the handset. The green light of the “unlock” symbol should light.

5.6.2.2 With the handset held as described above, press and release the mode button several times as necessary until the display has the thermometer symbol flashing at the top of the display. Press the set button to enter this mode, as shown below in figure 12.

Fig. 12

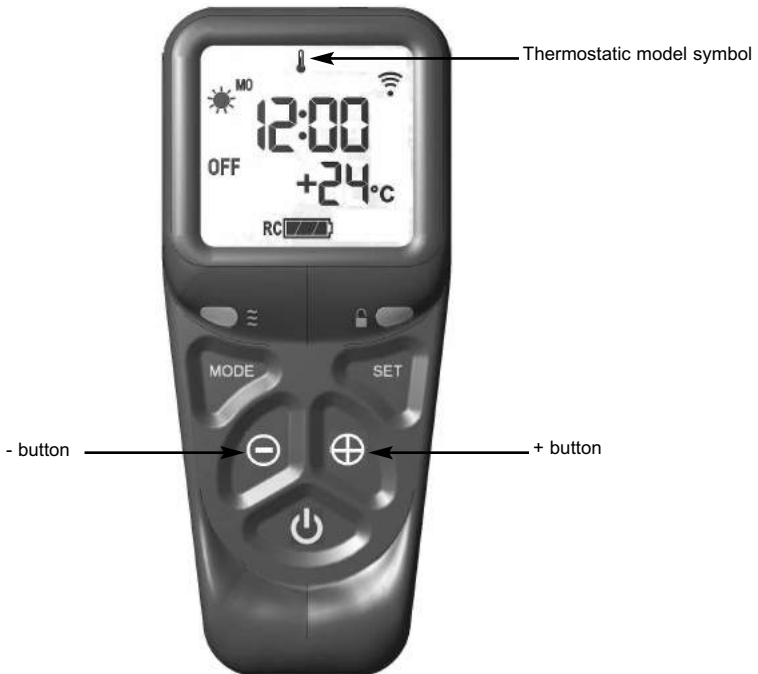

5.6.2.3 Press the set button again to see the temperature setting that is set (the default is 24 degrees celsius). If a different set temperature is required, whilst the display is showing this set temperature, press the + and - buttons to alter this setting, press the set button to store the required temperature, or alternatively the handset can be left for a few seconds and the temperature will be stored automatically.

5.6.2.4 If at any time the power button is operated during thermostat mode the control will cancel any thermostat operation and return the control to manual mode.

5.6.2.5 **IMPORTANT NOTE : Thermostat mode will not light the fire automatically and will only regulate between the maximum and minimum burner setting. The fire must be lit manually via the handset and then you enter thermostat mode as described in this section and set the temperature. When no longer requiring thermostat mode turn off the burner and the handset will return to manual mode.**

5.7 CLEANING INSTRUCTIONS

Before attempting any cleaning operation ensure that the fire has been allowed to fully cool. **Ensure the fire is disconnected from the electricity supply before commencing any cleaning operations.**

5.7.1 Cleaning the metal painted parts / optional trim

These metal painted parts should only be cleaned using a clean, damp cloth. **Abrasive cleaners, chemical cleaning agents or any type of polish must never be used as damage to the finish may result.**

5.7.2 Cleaning the fuel-bed

We do not recommend cleaning of logs or fuelbed components as these are fragile and damage may result. **None of these parts must be washed or exposed to any cleaning agents or water.** Any damaged parts must be replaced by contacting your dealer or telephoning BFM Fires on the number stated on the rear cover of this book. Logs must only be replaced with a complete and genuine replacement set and the fire must never be run with the wrong number or damaged logs. The fuelbed must be carefully re-assembled as stated in the following section.

5.7.3 Cleaning the glass panel

To clean the glass panel, please remove it from the product as described overpage. Use a clean damp cloth and ceramic glass cleaner to remove any stains or deposits from the glass panel. Do not use scouring pads as this may scratch the surface finish of the glass panel.

PLEASE NOTE :- The glass will require cleaning periodically. Condensation produced by the products of combustion will create marks on the inside face of the glass panel.

5.8 REMOVING / REPLACING THE GLASS PANEL

- 5.8.1 Remove the trim (if fitted) and front grill as below in figure 13 by lifting clear.

Fig. 13

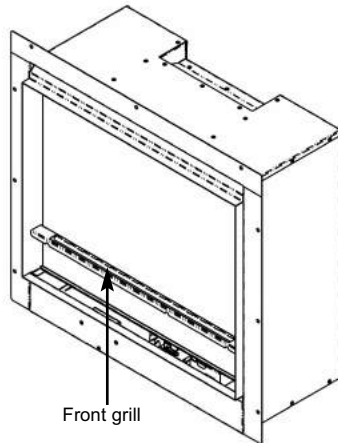

- 5.8.2 Remove the two off screws which secure the glass panel retaining bracket as shown below in figure 14, then tilt the glass panel forward to remove it.

Fig. 14

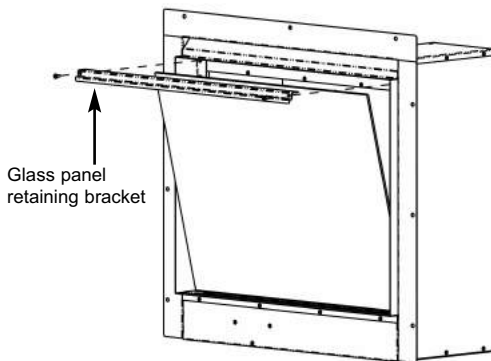

- 5.8.3 Store the glass panel in a safe place.
- 5.8.4 Re-assemble in reverse order when re-fitting the glass panel.
DO NOT OPERATE THE FIRE WITHOUT THE GLASS PANEL IN POSITION OR NOT CORRECTLY LOCATED.

5.9 REMOVAL & RE-FITTING THE FUEL-BED LOGSET

- 5.9.1 Place the L/H and R/H ceramic base pieces onto the ceramic support panel as shown below in figure 15.

Fig. 15

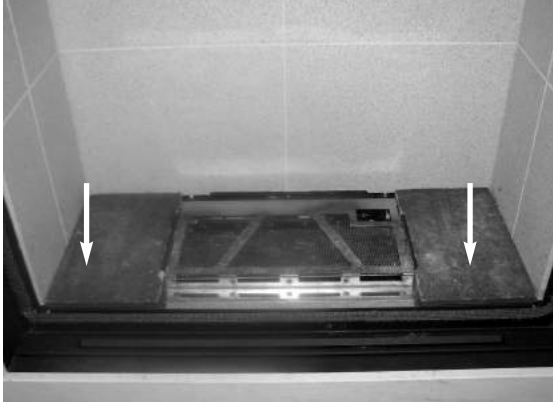

- 5.9.2 Place the front ceramic base piece onto the ceramic support ensuring the location tabs fit into the L/H & R/H ceramic base pieces as shown below in figure 16.

Fig. 16

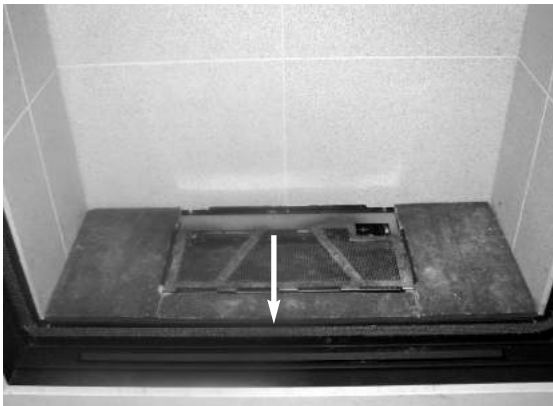

- 5.9.3 Place the base log onto the ceramic support panel as shown below in figure 17, ensuring the spacer locating blocks on the rear face are fitted flush up against the rear panel.

Fig. 17

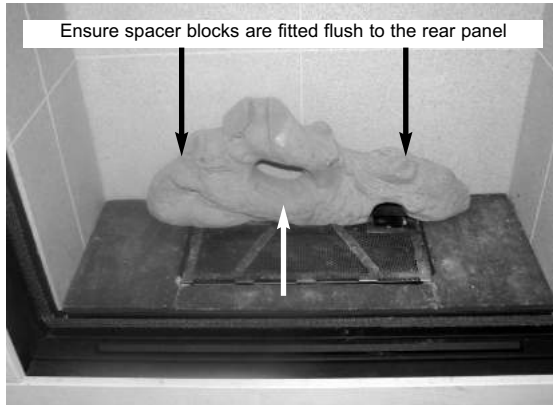

- 5.9.3 Cover the burner and fuel-bed base ceramic in a single, even layer of bark chippings as shown below in figure 18.

Fig. 18



5.9.4 Position log “H” onto the base log using the location lug on the back face of log “H” and the groove on the base log to find the correct location, as shown below in figure 19.

Fig. 19

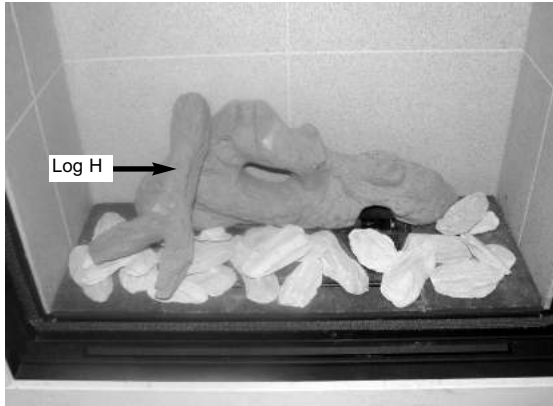

5.9.5 Position log “E” onto the base log using the location lug on the back face of log “E” and the groove on the base log to find the correct location as shown below in figure 20.

Fig. 20

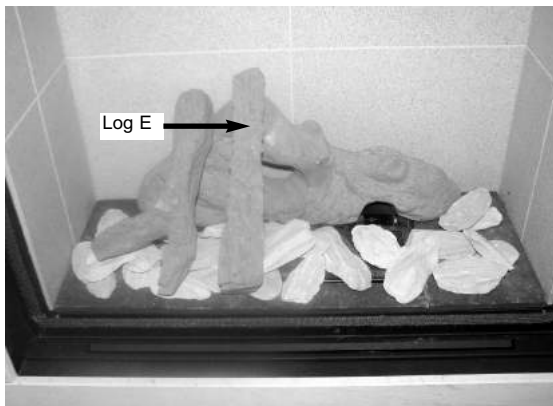

5.9.6 Position log “B” onto the base log using the location lug on the back face of log “B” and the groove on the base log to find the correct location as shown below in figure 21.

Fig. 21

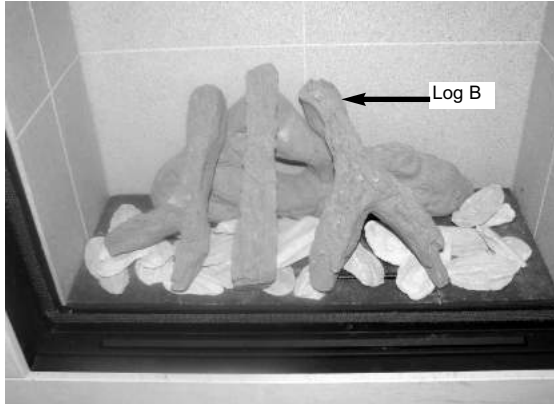

5.9.7 Position log “G” onto the base log using the location lug on the back face of log “G” and the groove on the base log to find the correct location as shown below in figure 22. Re-fit glass and optional trim (if fitted)

Fig. 22



Warning : Use only the logs supplied with the fire. When replacing the logs remove the old logs and discard them. Fit a complete set of logs of the correct type. Do not fit additional logs or any logs other than a genuine replacement set.

To ensure that the release of fibres from these R.C.F (Refractory Ceramic Fibre) articles is kept to a minimum, during installation and servicing we recommend that you use a HEPA filtered vacuum to remove any dust accumulated in and around the appliance before and after working on the appliance. When replacing these articles we recommend that the replaced items are not broken up, but are sealed within heavy duty polythene bags, clearly labelled as “RCF waste”. RCF waste is classed as a “stable”, non reactive hazardous waste and may be disposed of at a landfill licensed to accept such waste Protective clothing is not required when handling these articles, but we recommend you follow the normal hygiene rules of not smoking, eating or drinking in the work area, and always wash your hands before eating or drinking.

This appliance does not contain any component manufactured from asbestos or asbestos related products.

5.10

USER REPLACEABLE PARTS LIST

B-178790	Glass panel
B-179240	Complete log set
B-182650	Rear log only
B-182660	Log "B" only
B-182670	Log "E" only
B-182680	Log "G" only
B-182690	Log "H" only
B-179220	Fuel-bed base front
B-179230	Fuel-bed base side
B-182640	Spare bag of bark chippings

Part No. B-182910
Issue 2

BFM Europe
BRITISH FIRE MANUFACTURERS

BFM Europe Ltd.
Trentham Lakes
Stoke-on-Trent
Staffordshire
ST4 4TJ

www.bfm-europe.com

Telephone - General Enquiries : (01782) 339000
Telephone - Service : (0844) 7700169 or (01782) 339008