



BURLEY G4237/8 IMAGE FLUELESS GAS HEATER INSTALLATION, SERVICING & USER INSTRUCTIONS

FOR USE IN THE COUNTRIES STATED ON THE DATA PLATE AND CARTON
WITH NATURAL GAS G20
OR LPG PROPANE GAS G31
(REFER TO RATING LABEL)

For the following countries: GB, IE

**EVEN IF YOU HAVE FITTED THESE FIRES BEFORE,
PLEASE FOLLOW THESE INSTRUCTIONS STEP BY STEP.**

Legislation and regulations do change over time!

LEAVE THESE INSTRUCTIONS WITH THE USER

TO OBTAIN YOUR FIRST YEAR GUARANTEE, THE INSTALLER AND CUSTOMER
MUST FILL IN THE SEPARATE GUARANTEE AND RETURN IT TO
BURLEY WITHIN 7 DAYS OF FITTING.

A FREE SECOND YEAR GUARANTEE IS OFFERED SUBJECT TO THE FIRE BEING SERVICED
BY GAS SAFE™ REGISTERED INSTALLER (FORMERLY CORGI) DURING THE FIRST YEAR OF OWNERSHIP.
PROOF OF SERVICING MUST BE RETAINED
FAILURE TO HAVE THIS APPLIANCE FITTED BY GAS SAFE™ REGISTERED INSTALLER (FORMERLY
CORGI) FITTER INVALIDATES THE WARRANTY

Burley Appliances Ltd,
Lands End Way, Oakham, Rutland, LE15 6RB
Telephone: +44 (0)1572 756956 Fax: +44 (0)1572 724390
e-mail: info@burley.co.uk web: www.burley.co.uk

**G4237/8InstUser
G20/31
Issue March09– v.3**

INTRODUCTION

Thank you for choosing this burley product. All of our products carry a CE mark which is awarded by an independent test house (notified body) and shows the fires have been type tested to meet the essential requirements of the European Gas Appliance Directive and the appropriate British Standards.

This is a highly efficient Flueless Inset Live Fuel Effect Appliance. The burner system is very clean burning and a catalyst cleans the combustion products even further.

A thermostat in the burner control system adjusts heat output to maintain a room temperature, which can easily be set by the user. There is also a separate control to adjust the flame effect as required. Please demonstrate its operation to the customer before leaving.

An oxygen depletion sensing pilot light is also fitted and will sense any significant oxygen depletion in the room and shut the fire down safely.

1. APPLIANCE DATA

Refer to the appliance data (affixed beside control knob) **ENSURE THAT THE LOCAL CONDITIONS OF USE CORRESPOND TO THE DATA ON THE BADGE**

	Natural Gas G20	LPG (Propane) G31
Category	I2H	I3P
Supply Pressure	20mBar	37mBar
Inlet Pressure	20mBar*	37mBar*
Heat Input (net)	(High) 2.5kW (Low) 1.5kW	2.5kW (180g/h) 1.5kW (107g/h)
Inlet Connection	8mm Compression	8mm Compression
Injector	Manual Elbow 300 Remote Elbow 180	Elbow 90 Elbow 85

*The inlet pressure must be **within +/- 1mBar** of specification with **all** gas appliances in the house switched on **and also** with just the Burley heater operating. If outside of this tolerance the fault is most likely to be in the installation pipe work or service governor at the meter. If the problem is the meter governor, this is the property of the gas service provider (such as Transco / National Grid 0800 111999 or Bord Gais) and they should be called to rectify this. The fire will not operate correctly if the pressures are incorrect.

2. UNPACKING THE APPLIANCE

- 2.1 Carefully examine the carton for damage before unpacking. If it is obviously damaged, consult the supplier over whether to proceed.
- 2.2 Make sure the carton is stood upright and open the top. Remove the cardboard top fitting; this can be used as a hearth protector when installing the fire.
- 2.3 Remove the fittings boxes contained within and open them and check the condition of the contents. Remove the fire and examine its general condition, paying particular attention to the decorative frame, the glass front and fire box flanges.
- 2.4 **The fire case is attached to the chassis using clips and 2 transit screws in the lower rear of the case. These screws can be removed and discarded.**
- 2.5 If satisfied by the general condition, place the decorative components to one side and proceed with the installation. If in any doubt, seek advice from the supplier. **Read these instructions fully before proceeding even if you have fitted this model before.**

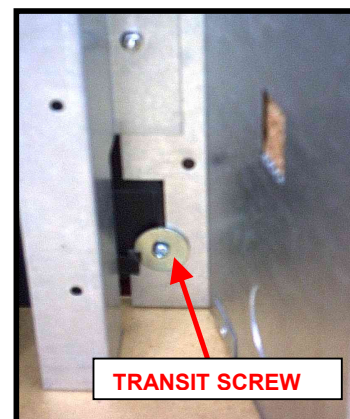

3. GENERAL REQUIREMENTS

- 3.1** Gas appliances must be installed in accordance with the rules in force. In the UK it is the law that all gas appliances must be installed by Gas Safe™ registered installer (formerly CORGI), in accordance with the Gas Safety (Installation and Use) regulations (as amended). The installation must also be in accordance with the relevant parts of local and national building regulations.
- 3.2** For the Republic of Ireland, reference should be made to IS 813 and ICP3 and any guidance notes from Bord Gais. Failure to have the fire fitted by a qualified person nullifies **ALL** guarantees. The space to be heated must have a wall vent of at least 100cm² of ventilation and an openable window. The vent must be positioned at least 1 metre away from the appliance.
- 3.3** In the Republic of Ireland two vents of not less than 60cm² each, one not less than 1.6m above the other, must be installed in the room.
- 3.4** When providing ventilator openings consideration must be given to the avoidance of locations where discomfort from draughts may cause the user to block the openings. Similarly the possibility of curtains or furniture blocking ventilation openings must be considered. **Floor vents, window vents or chimneys are not suitable means of ventilation.**
- 3.3** Working surfaces include the air outlet grille.
- 3.4** The heater must not be used in a room of less than 30m³ in volume. Adjoining spaces, not separated by a door may be included. To convert cubic feet (ft³) to cubic metre (m³) divide the room volume in cubic feet by 35.3.
- 3.5** The heater must not be installed in high rise blocks of flats, bed sitting rooms, basements which are not open on at least one side, bathrooms, or bedrooms, in corridors stairways landing or hallways of multi occupancy dwellings, garages or rooms containing petroleum products.
- 3.6** Soft furnishings, decorations and wall coverings etc. must not be placed within 1 metre of the appliance and its convection outlets (see 5.0). Be aware of curtains etc which could be blown towards the appliance.
- 3.7** The heater is intended as a secondary heat source. Check that a primary source of heat (such as radiators) is present in the room. If insufficient primary heat is being used there may be a build up of condensation.
- 3.8** The heater must not be used in rooms where the atmosphere is likely to contain water or chemical vapours which may adversely affect the appliance or its finish.
- 3.9** Do not use whilst painting & decorating, or in newly decorated rooms as the residues can lead to unpleasant smells from the appliance. Always cover or have the appliance removed when decorating.
- 3.10** Houses with warm air heating systems, solid walls, or no damp proof course may be unsuitable for flueless appliances.
- 3.11** This heater does not contain asbestos.
- 3.12** On no account should plasma screen televisions or similar be mounted above any heat source as damage could result.

4.0 PREPARING THE APPLIANCE

- 4.1** Unpack the heater (see 2.0). Ensure appliance is correctly marked for the gas it is to be used with. Take the appliance components and lay them out in an ordered manner. To prevent damage the decorative frame, fret, pebbles / coals and ceramic fire bed components can be placed safely to one side.

DO NOT ATTEMPT TO USE THE APPLIANCE WITH BROKEN/DAMAGED GLASS OR CERAMICS.
Contact our service department 01572 756956

4.2 Decide upon the route for the gas supply and if this is to be a concealed supply, select a suitable hole in the fire box, remove the knockout and lay in the supply as required. Fit the rubber grommet around the gas pipe entry to the appliance and seal.

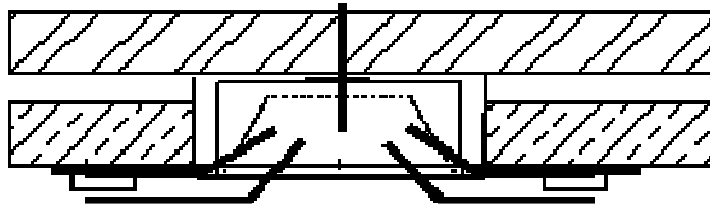

Before working on pipework, plug the ends to prevent the entry of debris. Decide upon the route for the gas and lay pipework as required. If the gas pipe passes through a wall, cavity or un-vented void then there should be no joins in this area and the pipes should be fully sleeved.

Note the supply can be either concealed through the holes in the appliance sides and back or surface fitted over the hearth and where pipes pass through walls they must be sleeved. In the case of remote control fires and wall mounted fires, all of the possible gas supply positions may not be available. Before pushing gas pipes through walls, seal the pipe ends to prevent debris entering the pipes.

Before connecting any pipes to the appliance, fully purge pipes of debris or swarf etc. and connect the gas supply to the 8mm elbow on the fire. Leak test the supply using an approved method. Note: An isolating valve must be situated near the appliance for servicing.

5.0 INSTALLATION INSTRUCTIONS

Note: The fires must be used as supplied with the smaller 60mm spacer fitted, failure to do so will make fitting the decorative case impossible & may overheat the fireplace and thus invalidate the warranty. Burley manufacture purpose made surrounds, which have been specially tested with the appliance for compatibility. The following guidelines must be adhered to.

The hearth must be a minimum of 12mm thick with the top surface standing a minimum of 50mm above surrounding floor level or surrounded by a raised fixed fender of 50mm high. The hearth must extend a minimum of 100mm in front of the fire bed and 50mm either side of the appliance giving an overall width of 732mm.

Closure plate tape and foam seals are unsuitable for fixing and sealing the fire into place. Always fix with the fixing cables, the wall brackets or through the base of the fire.

5.1 INSTALLATION METHODS

The appliance is a flueless visual flame heater designed to be installed in a number of ways, both freestanding, inset and wall or hearth mounted. This provides a great deal of flexibility. It can also be fitted without need for a fire surround or back panel, provided it is fitted against a non combustible surface. Any combustible materials directly behind the fire frame or back panel must be removed and replaced with suitable non combustible material such as superlux board, cement or similar.

The fire surround, back panel, hearth and all paints / lacquers etc must be of minimum 150°c rating. Please ensure this is the case and if necessary check with the manufacturer, as we cannot be held responsible for subsequent damage.

Note that paint and wall coverings on surfaces subject to heat can discolour and great care should be taken when choosing wall coverings.

5.2 METHOD ONE - FREESTANDING ON HEARTH OR WALL MOUNTED FULLY OUTSET

This method allows for surface / wall fixing of the fire using the deep spacers and deep brackets supplied without the need for insetting into a fire opening. The appliance gets very hot and could cause burns therefore if wall mounting without a hearth then care should be taken to avoid gangways and congested areas. Care should also be taken with curtains and soft furnishings to ensure there is no possibility of them touching the appliance.

Overall dimensions are as shown.

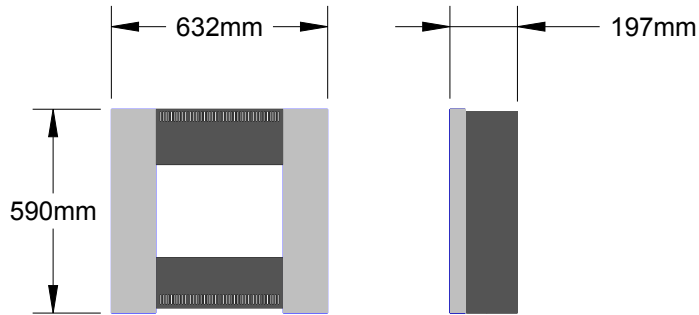

Hearths - For hearth mounting (or if the fire is less than 200mm above the ground) then the hearth must protrude at least 100mm in front of the fire and 50mm to either side. A minimum hearth of 732mm wide x 300mm deep is required, the hearth must be a minimum of 12mm thick and be of a non combustible material. The surface on which the appliance is to stand must be flat, level and square to the back panel. Failure to observe this could result in the appliance leaning away from the fireplace.

If the appliance is fitted on the wall, more than 200mm above the ground then a hearth is not required.

Chimneys & under grate draught devices – To prevent draught from affecting the stability of the appliance flames, all chimney openings and under-grate draught devices within 1 metre of the fire must be blocked off.

Fixing - The appliance should be secured to the wall using the fixing brackets on the flange of the appliance. If it is to be mounted above the ground, care should be taken to ensure the wall is able to take the weight of the appliance and that the fixings are of the correct type. Use all 6 screw holes in the brackets to attach to the wall.

If the appliance is hearth mounted the fixing is intended to prevent the appliance from moving / toppling and it is permissible just to use 2 holes in the wall brackets or to drill through the appliance base and screw it to the floor.

Do not fix the appliance directly to plasterboard as prolonged exposure to heat could affect it or the vapor layer behind. A layer of heat resistant board should be screwed to the wall instead.

Fully purge pipes of air and any debris and connect the gas supply to the 8mm elbow on the fire. Leak test the supply using an approved method. Note: An isolating valve must be situated near the appliance for servicing.

Site the thermostat at a suitable position where it will sense the room temperature.

The case can be test fitted to the chassis to ensure clearance. The gap in the case top between grille and spacer slides over the top flange on the appliance. The bottom of the case has folded out brackets that slide over cut outs in the appliance chassis.

The door on the appliance is secured with a magnet and it may be necessary to adjust the strength of the magnets grip. This can be done by bending the magnet holding bracket in or out to adjust.

Remove the case and place safely to one side.

5.3 METHOD TWO - INSET ON HEARTH OR INSET WALL MOUNTED

This method allows for the fire to be inset into a wall or fireplace opening. The appliance case has a 90mm deep spacer that needs to be removed and the corresponding deep brackets need to be taken off the case. **Note these are the only spacer and brackets to be removed and the smaller bracket and spacer must be left in place.** The appliance gets very hot and could cause burns therefore if wall mounting without a hearth then care should be taken to avoid gangways and congested areas. Care should also be taken with curtains and soft furnishings to ensure there is no possibility of them touching the appliance.

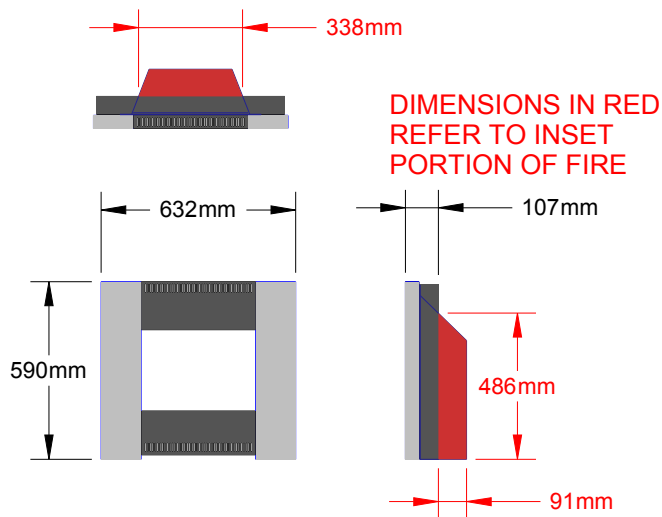

Hearths - For hearth mounting (or if the fire is less than 200mm above the ground) then the hearth must protrude at least 100mm in front of the fire and 50mm to either side. A minimum hearth of 732mm wide x 207mm deep is required, the hearth must be a minimum of 12mm thick and be of a non combustible material. The surface on which the appliance is to stand must be flat, level and square to the back panel. Failure to observe this could result in the appliance leaning away from the fireplace.

If the appliance is fitted on the wall, more than 200mm above the ground then a hearth is not required.

The hearth and back panel must be made from a non-combustible material although 'lightweight' and tiled surrounds can be used provided they have a minimum heat rating of 150°C. Consideration should be given to the effect of expansion and contraction caused by temperature and back panels should be allowed to float or attached with a flexible mastic on the extreme edges.

Fireplace opening sizes –

Height – 500 minimum	570 maximum
Width – 350 minimum	465 maximum

The fireplace opening must be a minimum of 100mm deep

Ensure adequate clearance from the fire to allow it to expand in the fireplace opening or it may crack the marble back panel.

To prevent heat from entering the area between the fireplace back panel and wall, the void must be blocked or packed with a non-flammable material.

Chimneys & under grate draught devices – To prevent draught from affecting the stability of the appliance flames, all undergrate draught devices within 1 metre of the fire must be blocked off.

If fitting into an existing fireplace or flue, the flue and cavity **MUST** be blocked off completely and cavity wall box CAV4241 fitted, to prevent suction on the back of the appliance (fit in accordance with the instructions supplied with the cavity box). The top of the flue should also be capped off to prevent the entry of moisture etc, consult building control if in any doubt.

If fitting into an opening in a cavity wall, or into a void, use cavity wall box (part no. CAV4241) and fit in accordance with the instructions supplied. Failure to do so can result in the pull from the cavity causing heat build up on the fire surround, back panel or moisture ingress from the cavity.

Fixing - The appliance should be secured to the wall using the fixing brackets on the flange of the appliance. If it is to be mounted above the ground, care should be taken to ensure the wall is able to take the weight of the appliance and that the fixings are of the correct type. Use all 6 screw holes in the brackets to attach to the wall.

If the appliance is hearth mounted the fixing is intended to prevent the appliance from moving / toppling and it is permissible just to use 2 holes in the wall brackets or to drill through the appliance base and screw it to the floor. Alternatively, hearth mounted appliances can use the cable fixing method by fixing eyebolts to the wall or fireplace behind and pulling it back into place. See diagram

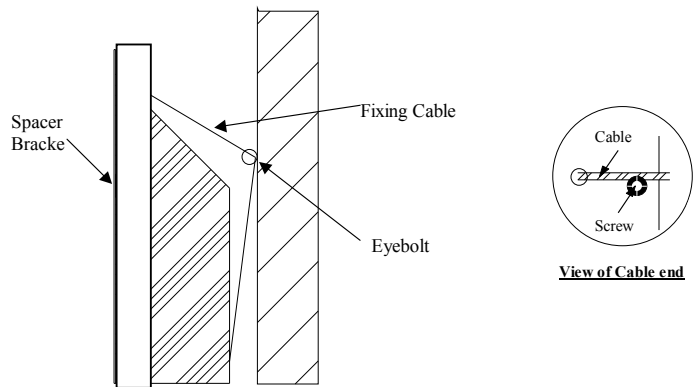

Do not fix the appliance directly to plasterboard as prolonged exposure to heat could affect it or the vapour layer behind. A layer of heat resistant board should be screwed to the wall instead. Fully purge pipes of air and any debris and connect the gas supply to the 8mm elbow on the fire. Leak test the supply using an approved method. Note: An isolating valve must be situated near the appliance for servicing.

Site the thermostat at a suitable position where it will sense the room temperature.

The case can be test fitted to the chassis to ensure clearance. The gap in the case top between grille and spacer slides over the top flange on the appliance. The bottom of the case has folded out brackets that slide over cut outs in the appliance chassis.

The door on the appliance is secured with a magnet and it may be necessary to adjust the strength of the magnets grip. This can be done by bending the magnet holding bracket in or out to adjust.

Remove case and place to one side.

6.0 CLEARANCES TO COMBUSTIBLE MATERIALS AND SHELVES (See also 3.6)

A non combustible shelf may be fitted to within 100mm of the top edge of the fire frame. Note that shelves will get hot and delicate ornaments, wax candles etc should be kept away from hot surfaces.

The wood of the fire surrounds may be fitted to within 100mm of the sides of the firebox provided it protrudes no further forward than 100mm.

Any combustible side walls must be at least 500mm from the fire bed.

Maximum depth of shelf	100mm	150mm	200mm
Minimum distance from top of frame to underside of shelf .	250mm	300mm	350mm

As with all heaters the possibility of convection staining on surfaces in the vicinity of the heater shall be considered and the user advised. Particular attention should taken to ensure soft furnishings such as scatter rugs and curtains are kept at least 1 metre from the appliance.

7.0 REASSEMBLY

7.1 To remove the glass, remove the 4 nuts in the side frames and pivoting it out from the bottom remove glass from its top channel. Refitting is done in reverse order.

7.2 REVERSIBLE SIDE CHEEKS

The appliance has side cheeks that are plain on one side and brick effect on the other. These can be removed and replaced by the installer to suit the customer's choice.

7.3 Refit the case before use.

7.4 Remote control fires –

The appliance uses a 7.2 volt rechargeable battery. This is supplied loose with the appliance to prevent inadvertent operation. To attach to the appliance, plug together the multiblock connector on the battery with the matching connector on the front right hand side of the fire. Then slide the battery into position underneath the fire in the purpose made battery housing. **Note – If the fire emits a beeping sound, this is just the safety system priming itself.**

Because the remote control uses battery power, when in the stand-by mode remove from the fire during long periods of non use. Be sure to brief the user on this as it will extend battery life considerably. The battery will normally last for 1 month, so demonstrate the way to charge the battery pack and also explain that the batteries are not covered by warranty.

A handheld remote control is included in the box and this has a 9 volt battery to power it. The battery should be changed annually to prevent false signalling caused by a partially flat battery. The battery is accessible through a flip off cover on the back of the handset and the battery clipped onto the terminals inside.

When disposing of batteries, always do so in an environmentally friendly manner.

Replacement rechargeable batteries for the fire and replacement handsets are available from Burley Appliances on 01572 756956 or through your retailer. The 9 volt handset battery is available from normal retail outlets.

8.0 PEBBLE / COAL LAYOUT



The base and front pebbles should be positioned as shown overleaf. The base locates onto the rear shelf and sits central and pushed back. The front pebble moulding is positioned centrally in its channel with the cut out on the right as shown. The coal shapes are similar to pebbles and fitted in a similar way.

Note the pilot position on the right hand side of the burner.

It is important for clean burning that the correct shape is fitted in the correct place. Do not use with incorrectly fitted pebbles.

Always replace the glass after laying the coals. Do not attempt to use the unit with broken / damaged glass or ceramics. Do not use additional or non standard ceramics.

9.0 TO LIGHT THE HEATER

BEFORE LIGHTING. IF THE PIPES HAVE NOT BEEN PURGED OF DEBRIS, DO SO NOW BEFORE LIGHTING THE FIRE. FAILURE TO DO SO WILL RESULT IN BLOCKAGES WITHIN THE PILOT.

BURLEY APPLIANCES IS THE ONLY COMPANY TO BENCH RUN AND THOROUGHLY TEST EVERY SINGLE GAS FIRE IT PRODUCES. BURLEY IS IN THE UNIQUE POSITION OF KNOWING THAT EVERY APPLIANCE LEAVES THE FACTORY IN PERFECT WORKING ORDER.

MANUAL CONTROLLED HEATERS

9.1 There are 2 control knobs on the appliance. The left hand one (coloured red) controls On / Off and High / Low flame. The right hand one (coloured black) is the comfort level thermostat which turns the fire down to pilot only once the desired temperature is reached. Some people prefer to retain a flame effect using the left hand red knob to control its height whilst keeping the thermostat black knob set on hot. Others prefer to use the fire purely as a heater in which case they will select a flame height on the red knob then set the thermostat black knob to a comfort level. In both cases if the room gets too hot, the thermostat will automatically reduce the fire to pilot setting until the room cools.

If during use the pilot is alight but the main burner will not light, check the thermostat position and if necessary select a warmer setting.

9.2 To light the fire, first ensure the red knob is turned clockwise to OFF. Press the left hand (red) control knob for several seconds then turn slowly anticlockwise to the ignition position. A click will be heard and the pilot (under right side of fuel

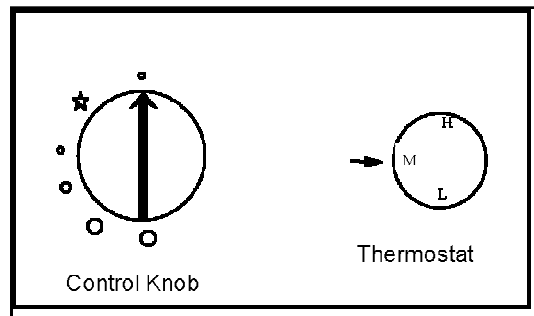

bed) should light. If it does not, repeat the operation a few times to purge any air in the pipe. Continue to hold knob for 15 – 20 second to establish the pilot and then release. If pilot fails to establish, turn off, wait 1 minute then repeat lighting procedure. Rotate the red knob to high flame to light then back to the desired flame position. If no gas comes through rotate the black knob (thermostat) to a hotter room setting and the fire will light.

9.3 Control the fire by a combination of thermostat and / or flame setting to suit your mode of use (see 9.1)

9.4 To turn the fire off, rotate the left-hand knob fully clockwise back to a vertical position.

Installation Instructions

NOTE – USE THESE INSTRUCTIONS TOGETHER WITH PUBLISHED DETAILS IN INSTRUCTIONS ABOVE.

If the fire tray is removed for installation, take care to route any fixing cables and gas supply pipes away from the workings of the burner tray.

Replace the tray and refit the entire coal layout, glass etc in accordance with the Installation Instructions.

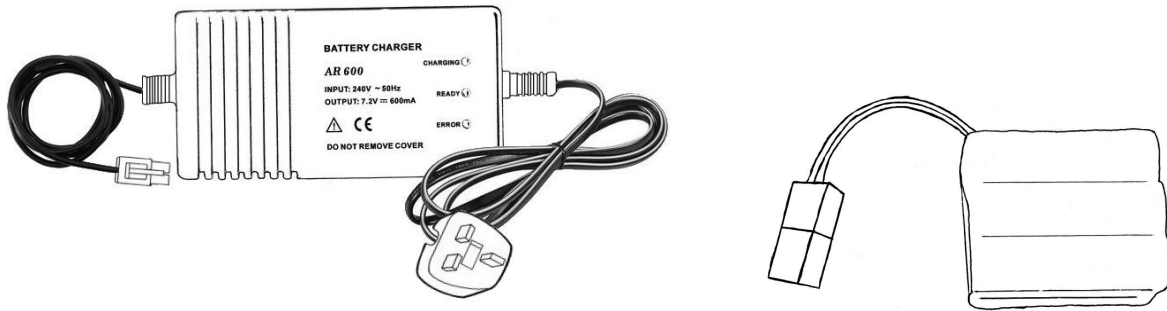

The fire comes with a special 7.2volt NiMh rechargeable battery, charger, and connection wire. This is supplied loose with the appliance to prevent inadvertent operation. To operate the product the battery must be charged using the supplied charger in the kit. The battery will take between 2 -4 hours to fully charge. In normal use, this will last 1 month before the battery requires recharging. The charger has indication lights to inform you of its status. (Actual product may look different from the pictures featured)

To attach to the appliance, plug together the multiblock connector on the battery with the matching connector on the front right hand side of the fire. Then slide the battery into position underneath the fire in the purpose made battery housing. **Note – If the fire emits a beeping sound, this is just the safety system priming itself.**

Because the remote control uses battery power, when in the stand-by mode. The battery will need charging on a monthly basis irrespective of use. If the battery is allowed to discharge then it may not be possible to re charge it.

A handheld remote control is included in the box and this has a 9 volt battery to power it. The battery should be changed annually to prevent false signalling caused by a partially flat battery. The battery is accessible through a flip off cover on the back of the handset and the battery clipped onto the terminals inside.

When disposing of batteries, always do so in an environmentally friendly manner.

Replacement rechargeable batteries for the fire and replacement handsets are available from Burley Appliances on 01572 756956 or through your retailer. The 9 volt handset battery is available from normal retail outlets. Please note that the cost is not covered by the guarantee.

Infra red sensor

This is on a retractable holder on the left hand side of the fascia. It is also possible to swivel the holder. Take the fret and ash pan and adjust the sensor position so that it is visible from under the fret. The handset must have direct line of site to the sensor in order for it to work.

Operating the appliance: See user’s instructions.

9.6 SPARK FAILURE

The gap between the pilot electrode and the pilot should be 3.5 – 4.5mm and normally adjustment is not necessary (the electrode is very brittle). The spark should jump across the gap between the electrode and the gas outlet on the pilot head. If the igniter fails a lighted taper can be inserted into the pilot area to check that gas is reaching the pilot.

10.0 COMMISSIONING

10.1 TEST THE GAS PRESSURE. Turn the fire on full, attach a manometer to the inlet test point and ensure there is a pressure of 20mb (+/- 1mb) for natural gas appliances or 37mb for propane appliances. Now turn on every other gas appliance in the house and re-check the pressure. The pressure must still be within the tolerance of +/- 1mb. Now turn off all the other gas appliances and turn the fire down to pilot only, the pressure must still be within the tolerance of +/- 1mb. If it is not TRANSCO, BORD GAIS or the propane supplier must be called to adjust the governor to the house before the fire can be commissioned further.

Brief the customer on the operation of the appliance and give them all the instructions. The customer must be told of the need for regular servicing of the appliance, this will be at least once a year and be made aware that no rubbish is to be thrown onto the fire bed. The customer must also be made aware that purpose provided ventilation should be checked regularly.

If you have any questions or the fire is not operating correctly, phone the Burley help-line BEFORE you leave the installation.

If the appliance is not fitted in strict accordance with these instructions, Burley cannot be held responsible for any damage caused and reserve the right to charge for any corrective work.

10.2 THERMOSTAT

A room temperature thermostat is provided. It is set for a normal range of operating temperatures but for more accurate monitoring of room temperature it is advised that the sensing bulb is removed from the fire and carefully moved to a cooler location up to 1 metre away, taking care not to break or pinch the capillary tube.

10.3 OXYGEN DEPLETION PILOT SYSTEM

There is a highly sensitive oxygen depletion sensor designed into the pilot light. If any part is damaged the entire unit must be replaced. Do not attempt to bend or alter the flame head, thermocouple or aeration hole. Use only genuine spare parts as similar looking parts from other appliances may well give different or inferior performance and could lead to a hazard.

10.4 FIREFRONTS

The design of these affects combustion, therefore only the correct front supplied with the appliance may be fitted.

10.5 FIREGUARDS

A fireguard is not supplied with this appliance; however it is recommended that a fireguard to BS6539 or BS6778 is fitted if the fire is to be used in the presence of young children, the elderly and the infirm.

10.6 COMPLETION OF WARRANTY CARD

The installer section of the guarantee card must be filled in fully to validate the warranty.

11.0 SERVICING INSTRUCTIONS

As with all gas appliances the unit must be serviced at least once per year, preferably at the beginning of the heating season. All servicing must be carried out by a qualified service person.

Before commencing any servicing, ensure that the gas is turned off to the appliance and that the appliance is cool.

Cleaning – If required the casing should be wiped with a cloth dampened in soapy water. The glass may be cleaned with any non-abrasive cleaner such as ‘hob brite’.

Lift the case to remove. Unscrew the four nuts holding the glass, remove and place thoughtfully to avoid damage or injury.

Carefully remove the front and rear coal sets and clean the burner and associated parts using a vacuum cleaner. Take particular care to remove all debris around the pilot light.

The ceramic fuel beds and side cheeks contain refractory fibre (RCF). Excessive exposure to these materials may cause temporary irritation to the eyes, skin and respiratory tract; consequently, it makes sense to take care when handling these parts to ensure that the release of dust is kept to a

minimum. We recommend the use of a HEPA filtered vacuum to remove any dust and soot accumulated in the heater before and after working on it. When replacing these articles, they should not be broken up, but sealed in heavy duty polythene bags labelled 'RCF Waste', which may be disposed of at a tipping site licensed for industrial waste. Normal hygiene rules of not smoking, eating or drinking in the work area should be followed.

Disconnect the gas supply to the appliance.

Undo the two nuts holding the burner assembly in the chassis. Remove the burner tray and examine it for general condition. Discoloration of the burner surface is normal.

Clean around the air inlet, removing all lint in the area of the injector and ensuring the pilot light aeration hole and flame head are clean. Injectors – Only original manufacturer's injectors must be used. Identification is as listed under replacement parts:

Should the oxypilot system need to be replaced, the original manufacturer's parts must be used.

Controls – The GAS CONTROL IS FACTORY SET AND NORMALLY NEEDS NO ADJUSTMENT. Check for smooth operation of the gas valve. Remove all covers, check the tightness of the thermocouple connection into the valve, the condition of the piezo and ignition leads.

On remote control fires check the condition of batteries, leads, control boxes and if necessary change the batteries in the fire and handset.

Examine the fire casing, the firebox and catalytic converter for obvious signs of damage or degradation. Clean out any dirt or dust accumulated in the bottom of the fire. Reassemble in reverse order.

Replace burner into chassis and reconnect to the gas supply. Test all joints for leaks.

Following the manufacturer's instructions, re-lay the fuel bed and replace the glass.

Light the fire using the method in the instructions and ensure that the pilot lights consistently and the pilot flame envelopes the thermocouple. The pilot should hold in 10 seconds. Turn control to main burner, this should light smoothly within 10 seconds. Ensure that valve gives adequate turn down and the thermostat bulb reduces the burner rate to off when heated. The gas manifold pressures are factory preset using highly accurate equipment and may be observed in the pressure test point on the valve. In the unlikely event of the pressure being incorrect it may be reset (refer to data plate for details), using a manometer or other pressure testing equipment.

Locate thermostat bulb in a cool place away from the appliance and preferably outside of any inglenooks, to ensure it is sensing room air temperature.

Run appliance for 10 minutes, ensuring burner flames settle evenly.

A combustion analysis check should then be carried out. Using an analyser to BS7927, first zero the equipment and sample the entire width of the combustion product outlet. Ratio of CO/CO₂ should be less than 0.002 within 30 minutes. (20ppm CO per 1% CO₂) A reading of CO in the room centre should give a rise of less than 9ppm over ambient, peak reading. The catalyst is unlikely to need replacement during the life of the heater but if the combustion is suspect, disconnect the appliance and contact the manufacturer.

Replacement Parts

Coal bed	COA4240	Pebble bed	PEB4240	Log Bed	LOG4240
Coal front	COA4241	Pebble front	PEB4241	Log Front	LOG4241
Pilot	Manual Control	Nat Gas - P4-41 or OP9110	LPG – P4-51		
	Remote control	Nat Gas – P502	LPG – P503		
Injector	Manual Control	Nat Gas – 300	LPG – 90		
	Remote control	Nat Gas – 180	LPG – 85		

USE ONLY GENUINE REPLACEMENT PARTS.

User Instructions

GENERAL REQUIREMENTS

The heater is intended as a secondary heat source. Check that a primary source of heat (such as radiators) is present in the room. If insufficient primary heat is being used there may be a build up of condensation.

The heater must not be used on or against a combustible surface. No furniture or curtains must be close to the appliance (or at risk of being blown close).

In the event of a gas leakage from the appliance, the gas supply must be turned off at the nearest isolating valve.

The area in which the fire is installed must have at least 100cm² of ventilation. (For Republic of Ireland 2 openings at high and low level, each of 60cm², with a vertical separation of at least 1.6 metres)

The heater must not be used in a room area of less than 30m³. Adjoining spaces, not separated by a door may be included. To convert cubic feet (ft³) to cubic metre (m³) divide the room volume in cubic feet by 35.3.

The heater must not be installed in high rise blocks of flats, bed sitting rooms, basements which are not open on at least one side, bathrooms, bedrooms, in corridors stairways landings or hallways of multi occupancy dwellings, in garages or rooms containing petroleum products.

The guard on the appliance is to prevent risk of fire or injury from burns and no part of it may be permanently removed. It does not give full protection for young children, the elderly or infirm. Parts of the appliance get hot; it is strongly recommended that an additional guard to BS6539 or BS6778 is used in the presence of children, the elderly or infirm.

This is not a drying appliance. Do not place clothing or other articles, on or against it.

Do not store or use flammable substances on or near the heater.

Do not spray aerosols on or near the heater.

If any material, such as plastic, melts onto the surface of the glass, turn the heater **off** and **allow it to cool. Do not remove the material when hot.**

When the heater is not to be used for a time, ensure the gas control or adjacent isolator are turned off.

The heater must not be used in rooms where the atmosphere is likely to contain water or chemical vapours, which may adversely affect the appliance or its finish.

Do not use whilst painting & decorating, or in newly decorated rooms as the residues can lead to unpleasant smells from the appliance. Always cover or have the appliance removed when decorating.

WARNINGS

Read the instructions before using this appliance.

This appliance requires installation and annual servicing by Gas Safe™ registered installer (formerly CORGI).

Use only in a correctly sized and ventilated area. Ventilation openings must never be blocked or restricted in any way.

Any purpose provided ventilation should be checked regularly to ensure it is free from obstruction.

Once the pebbles / coals have been positioned in accordance with the installation instructions, they must not be moved except for servicing. Material of any description must not be thrown onto the fuel bed.

The appliance must not be used unless the glass is fitted correctly.

The surfaces of the appliance become very hot during use.

On no account must inlet or outlet grilles be obstructed. See diagram.

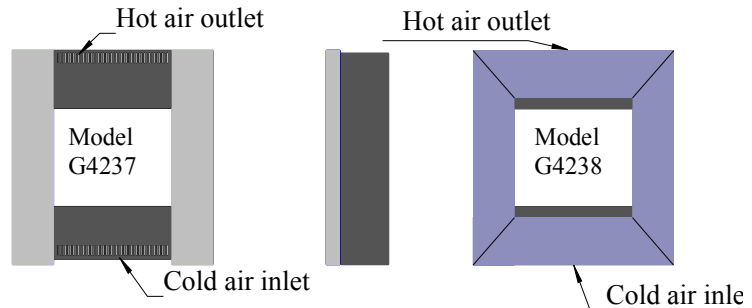

TO LIGHT THE HEATER

MANUAL CONTROLLED HEATERS

There are 2 control knobs on the appliance. The left hand one (coloured red) controls On / Off and High / Low flame. The right hand one (coloured black) is the comfort level thermostat which turns the fire down to pilot only once the desired temperature is reached. Some people prefer to retain a flame effect using the left hand red knob to control its height whilst keeping the thermostat black knob set on hot. Others prefer to use the fire purely as a heater in which case they will select a flame height on the red knob then set the thermostat black knob to a comfort level. In both cases if the room gets too hot, the thermostat will automatically reduce the fire to pilot setting until the room cools.

If during use the pilot is alight but the main burner will not light, check the thermostat position and if necessary select a warmer setting.

To light the fire, first ensure the red knob is turned clockwise to OFF. Press the left hand (red) control knob for several seconds then turn slowly anticlockwise to the ignition position. A click will be heard and the pilot (under right side of fuel bed) should light. If it does not, repeat the operation a few times to purge any air in the pipe. Continue to hold knob for 15 – 20 second to establish the pilot and then release. If pilot fails to establish, turn off, wait 1 minute then repeat lighting procedure. Rotate the red knob to high flame to light then back to the desired flame position. If no gas comes through rotate the black knob (thermostat) to a hotter room setting and the fire will light.

Control the fire by a combination of thermostat and / or flame setting to suit your mode of use (see 9.1)

To turn the fire off, rotate the left-hand knob fully clockwise back to a vertical position.

Note that if the gas supply fails at any time, the pilot will extinguish. Carry out the lighting procedure to re-ignite.

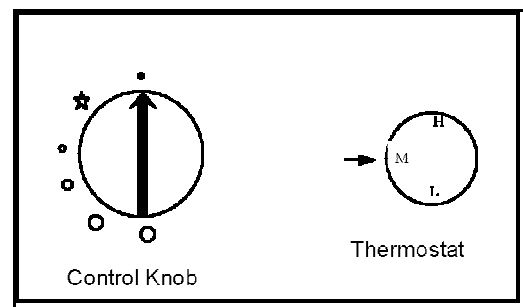

Remote Control Models.

1. Operating Instructions for remote operation

NOTE THIS SECTION REPLACES THE SECTION 'TO LIGHT THE HEATER' CONTAINED IN THE USERS INSTRUCTIONS

1. Batteries – The handset takes a standard 9v battery. This should be changed annually to ensure the fire continues to operate correctly. It can be accessed through a flap on the back of the handset.
The fire is fitted with a special 7.2volt rechargeable battery available from your retailer or from Burley Appliances on 01572 756956. It can be changed by simply sliding it out of its housing under the fire, undoing the connector block and carefully replacing with a new one
2. We regret that the warranty does not cover items such as batteries.
When disposing of batteries, always do so in an environmentally friendly manner.
3. On first operation, ensure the thermostat is set to the hot position.
4. Ensure the infra red sensor is visible. The fire relies on line of sight between the sensor and handset to operate. If a different fret is fitted it is possible to swivel and slide the sensor into a clearer position. In the event of the fire not working check both of the above points before calling an engineer.
5. To ignite the fire, point the handset at the fire, push and hold simultaneously the 2 left hand buttons marked * and ● for several seconds until the igniting sequence begins. The fire will automatically light the pilot light, monitor its safety for about 20 seconds and then it will light the burner on high flame.
6. To alternate between high and low flame use the flame buttons on the right hand side of the handset.
7. To turn the fire OFF press the ● button on the top left hand side of the remote handset.
8. The fire is fitted with a comfort thermostat behind the ash pan door and it is possible to set this to modulate the fire between off and on. If the pilot is alight but the main burner will not light, check the position of this thermostat before changing batteries etc.
9. An audible signal is heard when the fire receives a signal from the handset. This will help you to know that the fire has received your instruction and is changing settings. When the battery power is low, a continuous bleep will be heard from the fire and it will allow you to shut down safely but will not reignite. Please then recharge.

CLEANING AND MAINTENANCE

Ensure the appliance is switched off and cooled down before cleaning. The case and surround are best cleaned with a damp cloth and wiped dry to avoid smearing. The glass is a special high temperature ceramic material, if possible clean with a damp cloth, for more stubborn stains use a ceramic hob cleaner such as hob-brite and polish off all traces. Spray waxes and polishes that leave a residue, or abrasive cleaners must not be used.

The inside of the glass and fuel effects should need only infrequent cleaning. To do this, lift the case off its clips and place to one side. Remove the 4 nuts and washers holding the glass clips in place and put safe. Carefully remove the fuel effects, remembering how they fit in place and clean

around the burner area and fuel effects with a HEPA filtered vacuum with brush attachment. Using the relevant section from the installers manual refit the fuel effects, glass and case.

On no account should the fire be used with glass removed. The fuel effects must not be replaced in a different position from the instructions, if they are broken replace immediately. Do not use additional or non standard fuel effects as to do so could cause a hazard.

If the fire is equipped with a remote control then check and change the batteries as described in previously.

The fire should also be serviced annually by a competent person: Gas Safe [™] registered installer (formerly CORGI) in the UK. This is best done before the heating season.

NOTES

The first time that the appliance is used, there will be some odour produced due to the newness of the materials. It is recommended that the unit is fired at maximum setting for several hours and the room is kept ventilated during this period. It is usual for flueless appliances to produce an initial odour after start up.

If the pilot flame should ever extinguish of its own accord, ventilate the room and allow a minimum of 5 minutes before relighting.

Never attempt to relight the unit if there is a gas smell, ventilate the room first.

If the unit continues to extinguish after a period of use, do not use it and seek the advice of your installer.

GENERAL

To qualify for your free second year guarantee, you must fully complete and return the separate Guarantee Card. There are sections that your fitter must complete whilst he is fitting the fire. If the fully completed Guarantee Card is not returned within 7 days of fitting, the appliance is just covered by the standard 12 month guarantee.

As with all gas appliances, this fire **MUST** be serviced at least every 12 months, preferably at the start of the heating season. The second year guarantee is conditional on this service taking place. Servicing must be carried out by a qualified service engineer.

BURLEY APPLIANCES ARE THE ONLY COMPANY TO BENCH RUN AND THOROUGHLY TEST EVERY SINGLE GAS FIRE IT PRODUCES. BURLEY ARE IN THE UNIQUE POSITION OF KNOWING THAT EVERY APPLIANCE LEAVES THE FACTORY IN PERFECT WORKING ORDER.

ADDITIONAL INFORMATION

1. Flue Gas Analysers – Installation & Servicing Facts

- Please read this sheet even if you have fitted our fires before.
- Please leave this sheet with the customer as reference for future servicing of the appliance.
- Please explain to the customer how the fire works and the details and facts listed on this sheet, particularly what the catalyst does and doesn't do.
- If you have any doubts about the test procedure please visit our website or call our technical help line

Testing – Points to note...

- Before testing ensure that the room size is correct for the heat output of the fire. 30cu³ for 2.5kw output, 40cu³ for 3.5kw and 50cu³ for 4.5kw.
- In all installations regardless of room size there must be an air vent positioned at least one metre from the fire at either high or low level through an outside wall providing 100cm² of free air. (For the Republic of Ireland 2 vents of not less than 60cm² must be provided at high and low level, with minimum vertical separation of 1.6m).
- The analyser used must be manufactured to BS7967 and the test must be carried out in accordance with BS5871 Pt 4
- The catalytic converter needs heat to work, therefore before you start testing; the fire must have been lit and burning on full for at least 15 mins.

There are two tests to carry out. A Co / CO² ratio test and a room centre CO test.

1. The first test is the CO / CO² ratio test and should be carried out at the fire exhaust vent, do not stick the probe of the analyser in through the grill but move the probe back and forth 1 inch in front of the outlet grill. (We use a piece of perforated 8mm pipe attached to the analyser with flexible rubber tube). You should record a ratio of no more than 0.002 % (20ppm CO to 1% Co²). It is advisable to have a high sample of CO as this will improve the test
2. The second test is the room centre CO test. You should stand in the room centre with the probe at waist height and read the level of CO; this should be no more than 9ppm over ambient peak. Please record these readings on the customers guarantee card.

Our Flueless fires also contain the following safety devices (an ODS (Oxygen Depletion Sensor) and FSD (Flame Supervision Device). Point out to the customer that unfortunately these are not found on all gas hobs; which are also flueless devices)

2 **Points to Note Regarding the Catalytic Convertor!**

- If the customer smokes tobacco products, lives on a busy road or is cooking with a gas oven/hob at the time of testing you must ensure that an ambient CO reading is taken before lighting the fire and attempting a reading.
- *Does the catalytic convertor need replacing?* The catalytic convertor does not need replacing unless it has become physically broken or the combustion test shows deterioration in performance over time. To constantly test the performance of the catalytic converter, our laboratory has been running appliances eight hours per day, five days per week, for up to seven years. Periodically we send catalytic converters back to the manufacturer for testing. After the equivalent of 30 years of use, the catalytic converter is as efficient as it was when brand new. Burley manages to achieve this by designing the fire to ensure that the catalytic converter is in exactly the right position for long life and maximum efficiency. (For other makes of fire please consult the relevant manufacturer). Only use replacement catalyst supplied by Burley.
- If you or the customer detects any odours from the fire please remember that the catalytic convertor is not an air filter and does not remove smells. The ceramics in the fire can absorb household smells and in turn these smells get emitted when the fire is lit, especially if the fire is used in an enclosed space for a period of time. If this is the case we recommend that the fire is run on maximum for at least 5 hours with the doors and windows open. This should be done at least twice a year, preferably in the spring and autumn or at any time they notice a smell.
- We do not advise the burning of wax candles within 1 metre of the fire. Wax particles can become airborne and deposit and solidify in the fire causing potential combustion problems.
- The catalyst can also be affected by airborne paint smells and vapors from some plug in air fresheners. The fire must be removed or sealed if you plan to decorate anywhere in the house. If you can detect smells from the fire carry out the burning off procedure as above.

Further information regarding the catalytic convertor and Flueless fires in general can be found on our website www.burley.co.uk

3. Gas rating of Burley Flueless Appliances

Burley's Flueless Gas Appliances are all gas input rated in the factory and undergo further line tests for combustion, sooting and visual performance. For Installers who wish to gas input rate appliances we need to establish tolerances for pass and fail.

Manufacturers Tolerances

The Heat Input on appliances can be expressed as either a Nett or a Gross figure. When the installer is gas rating from the meter they will be using gross heat input which is 10% higher than Nett. This conversion has to be taken into account if the manufacturer has quoted a nett figure.

The manufacturer also has to account for production tolerances on pipes, injectors, valves etc and is allowed a further +/-5% tolerance on the maximum rate.

Burn Down

Cold appliances generally allow a greater rate of gas to pass through them and once the appliance warms the gas density alters and causes the rate to reduce to the figure stated. This is known as Burn Down.

Manufacturers carrying out their technical tests allow appliances to be fully warm and burn down before taking readings and this is typically after 1 hour. Some appliance manufacturers quote a 'cold' figure for the gas rate so that installers can measure this immediately.

Installer Tolerances

It is important to take a gas rate test over a reasonable period of time so that the capacity of the meter is used. On low Input appliances such as our flueless this is even more critical because uncertainties can creep in. It is worth measuring over a 5 minute period to make sure.

It is also important to get your inlet pressure to 20mBar.

In a gas appliance factory compensation is also made for variations in

- % Saturation of Gas
- Variation in Calorific Value
- Variation in Gas Density
- Gas Temperature
- Gas Pressure
- Atmospheric Pressure
- Meter Calibration
- Stopwatch Calibration.

In the home it is not possible to correct for these therefore an uncertainty factor needs to be built into all measurements.

Currently the Gas Safe™ registered (formerly CORGI) does not quote a figure on this uncertainty but the measured gas rate could vary by +/-5%.

Conclusion

In adding all the variables together,

- an appliance quoting Gross Heat Input could be anything from +/-10% of the quoted heat input
- an appliance quoting Nett Heat Input could be anything from 0% to +20% of the quoted figure when measured as a Gross figure.
- If the appliance is cold anything up to a further 10% error could be expected and we don't quote these figures because they change rapidly. The figures shown below are hot figures.

Model	Heat Input Quoted	Minimum (Gross)	Maximum (Gross)
Environ, Esteem	2.5kW Nett	2.5kW Gross	3.0kW Gross
Ambience 4121	3.5kW Nett	3.5kW Gross	4.2kW Gross
Acumen / Elan 4111	4.5kW Nett	4.5kW Gross	5.4kW Gross

4. Burley Appliances Ltd - Domestic Guarantee Conditions?

We pride ourselves on the quality of service we deliver to our customers and all Burley Appliances' products carry a fully inclusive 12-month parts and labour guarantee. This guarantee is extended by another 12 months free of charge provided that your appliance is registered with us within two weeks of installation and that it is serviced by Gas Safe™ registered installer (formerly CORGI) at the end of the first year. What the guarantee cannot cover is problems caused by incorrect installation or servicing, or any work carried out by a non- Gas Safe™ registered installer (formerly CORGI).

We undertake that if within 12 months of the date of purchase, your fire or any part thereof is proved to be defective by reason of faulty workmanship or materials, we will at our discretion repair or replace the same free of any charge for labour, materials or carriage subject to condition that:

- All gas appliances are installed to the latest Gas Installation regulations by a qualified Gas Safe™ registered installer (formerly CORGI) and connected to the correct gas type and pressure as stated on the rating plate attached to the equipment.
- The fire is fitted in a room with the following minimum dimensions 2.5Kw = 30m³ / 3.5Kw = 40m³ / 4.2Kw = 50m³
- A wall vent is installed not less than 1 meter away from the fire allowing 100cm² of free air.
- You have the fire serviced by a Gas Safe™ registered installer (formerly CORGI) within the first year (as with all gas products, every gas appliances must be serviced every year).
- The appliance has not been subject to misuse, accident, or repaired or fitted by anyone other than a Gas Safe™ registered installer (formerly CORGI) or our own engineer.
- The appliance has been used solely for domestic purposes and is on domestic premises i.e. not for commercial or trade use.
- The appliance has been used solely in accordance with the instruction book.

Any in guarantee work carried out by Burley Appliances will be charged for if the fault is caused by **incorrect pressure or gas, incorrect installation, operator error, neglect or abuse.**

All guarantee cover is instantly and permanently cancelled if a non- Gas Safe™ registered installer (formerly CORGI) carries out any installation or servicing.

Exclusions

This guarantee **does not** cover:

- Damage resulting from external transportation, improper use or neglect, the replacement of any light bulbs or removable parts of glass or plastic.
- Costs incurred for calls to put right an appliance, which is improperly installed.
- Appliances that are the subject of rental agreements.
- EC Countries - the standard guarantee is applicable but is subject to the owner's responsibility and cost, to ensure the appliance meets the standards set by the country to which the product is taken.

Any appliance or defective part replaced shall become the Company's property

Service Calls are made between 09.30 am and 04.30 pm Monday - Friday.

This guarantee is in addition to your statutory and other legal rights.

Proof of purchase will be required as will be a copy of the Gas Safe™ registered (formerly CORGI) installer notice.