



## **Installation and Operation Manual**

### **York Midi Gas Stove**

Revision: TJ09b

## TECHNICAL INFORMATION

	<b>NATURAL GAS G20/I2H</b>	<b>PROPANE G31/I3P</b>
Heat Input (Gross)	6.2 Kw/Hr	6.0 Kw/Hr
Supply Pressure	20 Mbar	37 Mbar
Gas Rate	0.59 M <sub>3</sub> /Hr	0.23 M <sub>3</sub> /Hr
Injector Size	C.A.T. 28/420	C.A.T. 16/160

## CONTENTS

ARRANGING THE LAYOUT OF THE COALS .....	8
DIMENSIONS & DETAILS .....	2
EXTINGUISHING THE STOVE BACK TO PERMANENT PILOT SETTING .....	9
EXTINGUISHING THE STOVE FULLY .....	9
FLUE CONNECTION .....	6
GAS CONNECTION .....	7
GUARANTEE .....	OUTSIDE BACK COVER
IGNITING THE PERMANENT PILOT LIGHT .....	9
IMPORTANT INFORMATION .....	3
NOTE TO THE INSTALLATION ENGINEER .....	10
OPERATING THE STOVE .....	9
PRESSURE TESTING .....	7
RUNNING THE STOVE AT A HIGHER OUTPUT .....	9
RUNNING THE STOVE AT LOW SETTING .....	9
SERVICING INSTRUCTIONS .....	13
SITING THE APPLIANCE .....	4
SPILLAGE MONITORING SYSTEM .....	11
STOVE ASSEMBLY .....	5
TEST FOR SPILLAGE .....	10
TROUBLESHOOTING .....	12
VENTILATION .....	6

### **Broseley Fires Ltd.**

Knights Way, Battlefield Enterprise Park, Shrewsbury, Shropshire SY1 3AB  
Tel: 01743 461444 Fax: 01743 461446

## 2. DIMENSIONS & DETAILS

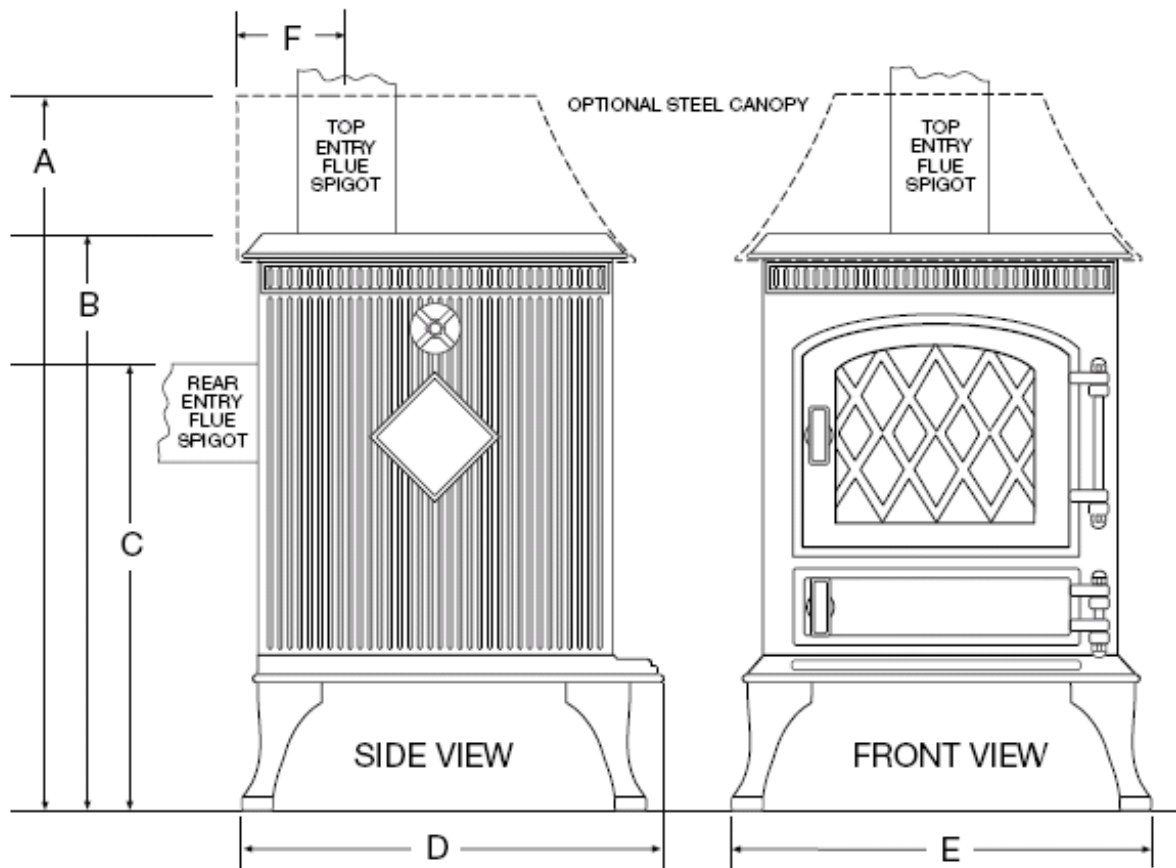

<b>A</b> - Height with optional canopy .....	762mm (23")
<b>B</b> - Height Flat Top .....	584mm (30")
<b>C</b> - Height To Top Of Rear Flue Spigot .....	540mm (21¼")
<b>D</b> - Depth .....	406mm (15¾")
<b>E</b> - Width .....	457mm (18")
<b>F</b> - Centre Of Top Flue To Rear Of Stove .....	127mm (5")
Width of canopy .....	508mm (20")
Depth of canopy .....	413mm (16¼")
Flue Spigot Diameter .....	127mm (5")
Weight Excluding Optional Canopy .....	.65kg (143 lbs)
Maximum Heat Output (approx) .....	4.6 kilowatts

## **THANK YOU FOR PURCHASING A YORK MIDI GAS-FIRED STOVE**

*Broseley Fires Ltd, a family run company, was founded as a gas appliance design and development company in 1975.*

*Since then we have built up an enviable reputation for the quality, reliability and fuel efficiency of our stoves.*

*These instructions have been carefully prepared to guide the installer and end-user through the relevant methods and standards for installation of your new York Midi Gas Stove. Correctly installed and operated, your Stove will give you many years of warmth and reliability. Therefore, we would suggest that you read the whole instruction manual prior to handing it to your installer. That way you will have a clearer picture of what is involved.*

### **3. IMPORTANT INFORMATION**

#### **APPLIANCE TO BE INSTALLED IN ACCORDANCE WITH NATIONAL REGULATIONS**

1. The York Midi is a gas stove designed to run on either natural gas or LPG. The burner units are not interchangeable between the two types of gas. This stove is a radiant convector fuel-effect appliance. The site of the stove i.e. the chimney, flue and hearth etc., must comply with current building regulations and codes of practice before the stove is installed.
2. It is required by law that the complete assembly, installation and commissioning of gas-fired stoves is carried out by a professionally qualified and accredited gas fitter listed on the "gas safe" register.
3. **DO NOT ATTEMPT TO INSTALL THIS APPLIANCE YOURSELF.** Broseley Fires Ltd take no responsibility for any breach of the legal standards prevailing as far as the fitting of this appliance is concerned.
4. Warmland Stoves are efficient appliances, giving off convected, conducted and radiated heat. All services of the stove except the control knob are considered to be working surfaces. Adequate precautions should always be taken to protect children, the elderly, the infirm and pets etc. from coming into contact with the stove.
5. Ensure that the local gas distribution conditions, the nature of the gas pressure are compatible with the data plate fitted between the right hand legs and on the control valve

These instructions have been compiled in accordance with BS5258 part 12:1986. The Gas Safety Installation and Use Regulations 1994. The Building Regulations (issued by the Department of the Environment). The Building Standards (Scotland)(consolidation) Regulations

## **4. SITING THE APPLIANCE**

The gas supply connection to the appliance is at the rear right hand side. The connection requires 8mm diameter semi-rigid pipe, not more than 1 metre in length.

The appliance can be installed in any adequate area suitable for solid fuel fires and stoves.

To ensure maximum and efficient use of the stove, we recommend the following hearth specifications:

1. The hearth must be made of non-combustible material at least 12 millimetres thick. The hearth must at least 300mm at any angle in front of the incandescent heat source i.e. the burner surface of the stove and requires a clearance 150mm each side.
2. On all stove installations, no combustible material should cover the hearth. To prevent this from happening, the hearth should be at least 50mm above the level of the floor, or a fender/kerb of a similar height should be placed around the edge of the hearth.

If the appliance has to be located in an opening, there must be a clearance of a minimum of 100mm each side of the stove to any non-combustible materials. The rear of the appliance should have a minimum 75mm air gap between the stove and the back wall.

## 5. STOVE ASSEMBLY

Please check that the following components are included before you start on the assembly:

### Stove Box

- 1 x Cast Iron Stove Body
- 4 x Stove Legs
- 4 x Sets of Nuts, Bolts and Washers,
- 1 x Flue Spigot
- 1 x Flue Closure Plate

### Burner Box

- 1 x Burner Unit
- 1 x Instruction Booklet (This document)
- 1 x Screw & Washer (To affix gas burner in place)
- 1 x Remote/ Receiver

### Ceramic Box

- 1 x Base Coal Matrix
- 1 x Front Coal Matrix
- 1 x Rear Coal Matrix
- 5 x Small Loose Coals

Before installing the stove ensure the gas to be used i.e. natural (mains) gas or LPG corresponds with the identification plate on the burner.

Carefully lay the stove on its back and fit the four legs using the nuts, bolts and washers provided.

Loosen the grub screw situated in the side of the brass "T" handle, unscrew the "T" handle and open the main stove door.

Next, stand the stove upright and insert the burner (control first) through the door. Dip the controls through the bottom of the stove so that the burner comes to rest onto the brackets located on each side

Finally, locate the self-tapping screw through the bracket provided on the rear of the burner to prevent any small movement when making adjustments to the gas control.

## **6. FLUE CONNECTION**

The stove must be installed in accordance with current gas and building regulations BS5871: Part 1

Before you install the stove make sure the chimney flue outlet is correctly positioned to align with the flue outlet on the stove and that the chimney is in good condition. If not, a chimney liner must be installed or a suitable class II gas flue used. A draught is necessary to ensure the products of combustion are fully evacuated. Due to the internal dilution/diversion system in the York Midi Stove, it is not obligatory to line the chimney providing that it has been inspected by a CORGI registered installer and passed as suitable/sound.

The York Midi Gas Stove is suitable for both Class I & II flues (The Building Regulations 1984). The appliance is also suitable for pre-cast flues, pre-cast chimney block, pre-cast flue block and ridge tile vent

Ideally it is recommended that a minimum height of 610mm from the stove should be established before any significant change of the direction of the flue. Horizontal or negative gradients should be avoided. The flue must have a minimum height of 3 metres to ensure adequate draught

Prior to installation, the installer should ensure that the flue is free from obstruction and any dampers must be fixed in a permanently open position. Ensure the chimney is not closed and that it has been swept and subsequently smoke tested.

Make sure that rain, birds, or any foreign body cannot get into the chimney to cause damage or a blockage. This problem can normally be overcome by fitting an approved Gas Cowl. It is essential for the effective running of your stove that the chimney draws properly to allow the products of combustion to escape

### **VENTILATION (GB ONLY)**

The York Midi Gas Stove is rated at less than 7 kW and therefore does not normally require additional ventilation in the room (BS5871-part II).

## 7. GAS CONNECTION

A minimum 15mm diameter gas supply pipe must be used to within 1 metre of the installation with the final connection to the stove to be completed with the suitable 8mm semi-rigid gas pipe. The 8mm pipe should be connected to the inlet of the gas valve using the nut and 8mm olive provided, support the control whilst finally tightening the supply pipe.

## PRESSURE TESTING

Always make sure that there is adequate gas pressure and volume to the stove. The relevant pressures are on the ID plate on the gas control knob.

1. **For natural gas, this is 20mbar** measured at the burner test nipple situated at the inlet connection to the stove with the appliance in the full rate position.
2. **For propane, this is 37mbar** measured at the burner test nipple situated at the inlet connection to the stove with the appliance in the full rate position.
3. Ensure that the gas pressure to the stove is maintained when it is operating at the same time as other appliances in the building and that a suitable pressure gauge is used i.e. a manometer

**Any service call as a result of incorrect gas pressure will be chargeable.**

## 8. ARRANGING THE LAYOUT OF THE COALS

Only the ceramic coals supplied with this appliance should be used. The coals should only be laid as shown in the following diagrams. Replacement coals are available from your dealer.

Whilst arranging the coals, ensure that the pilot is not obstructed

Broseley Fires Ltd accept no responsibility for any injury sustained whilst handling hot Ceramics

Before any ceramics are placed in position ensure that the burner is operating correctly. The flames should be fairly even across the burners mesh top.

**Ceramics which are found to be placed other than in accordance with these instructions will result in a charge being made following any service callout**



## COAL LAYOUT

Added Coals shown in white for identification only.

### Stage 1

Place largest coal matrix firmly against the back of the stove with the three arches to the bottom and central above the burner mesh.



### Stage 2

Place the smaller of the two remaining coal matrixes in front of the previous section with the pilot cut-out to the bottom. Then ease the two pieces forward so that they are a snug fit at the front.



### Stage 3

Place the final coal matrix on top of the largest coal matrix and push firmly against the back of the stove. Ensure that it is central and the two largest coals in the matrix are facing forward.



### Stage 4

Place 3 loose coals on top of the 3 large coals of the largest matrix so that they are pushed to the back. The other 2 loose coals are placed in the gaps between the 3 large coals of the large matrix. There should be no loose coals on top of the matrix that is positioned over the pilot.



## IMPORTANT

Please follow these instructions carefully. Ceramics that are positioned incorrectly could seriously alter the performance of your appliance.

## 9. OPERATING THE STOVE

**It is important to read these instructions thoroughly before lighting the stove.**

### **CURING THE PAINT**

Most high temperature paints operate in the same way. They use a resin which dries at room temperature and a silicon resin which cures at high temperatures. When the stove is burned the dry resin burns away and the silicon cures. This transition occurs about 475° F

After the stove burns about four times, the entire surface which gets hot should have cured. The house needs to be fully ventilated during these initial burnings and although the smoke is mostly Carbon Dioxide there are other components of the smoke which make it smell bad and may irritate some people. These effects will go away after the first few burns depending on the duration and surface temperature of each burn. The hotter the stove gets, and the longer the duration of burning, the quicker it will cure.

**PLEASE EXPLAIN TO THE CUSTOMER THESE LIGHTING AND EXTINGUISHING PROCEDURES AND THAT IT IS NORMAL FOR THE STOVE TO GIVE OFF ODOURS WHILST THE PAINT MATURES.**

The York Midi Gas Stove operates with a traditional permanent pilot light. The knob for ignition and power control is located on the lower right hand side of the stove. The pilot light is located at the front middle of the coal matrix. If the Flame Supervision Device Actuating Flame (the pilot light) is extinguished either by intention or not, no attempt should be made to re-light until **3 minutes have elapsed**.

### **(A) IGNITING THE PERMANENT PILOT LIGHT**

1. Depress control knob fully.
2. Whilst depressed, turn knob sharply 90 degrees anti-clockwise to "Pilot" setting. Repeat until pilot light is visibly lit.
3. **KEEP KNOB DEPRESSED AT THIS POINT FOR 15-20 SECONDS.**
4. Upon releasing the knob, the permanent pilot light will be lit.

### **(B) RUNNING THE STOVE AT LOW SETTING**

1. Ignite permanent pilot light as shown in A1 (above).
2. With control knob at "Pilot" setting, depress and turn in an anti-clockwise direction to "LOW" setting.
3. Release the knob. The stove is now burning at its lowest operating output.

### **(C) RUNNING THE STOVE AT A HIGHER OUTPUT**

1. Ignite stove to "low" setting by following instructions in A1 and B2 (above) respectively.
2. Output can be increased, by turning the control knob progressively in an anticlockwise direction until the desired level is achieved, up to a maximum as shown by the "HIGH" symbol on the control panel.

**(D) EXTINGUISHING THE STOVE BACK TO PERMANENT PILOT SETTING**

1. From any heat setting, depress control knob fully and turn clockwise to "Pilot" position Release

**(E) EXTINGUISHING THE STOVE FULLY**

1. From any heat setting or the permanent pilot, depress control knob and turn clockwise to "OFF" Position. Should the Glass door become broken or damaged in any way, turn your stove off and do not attempt to re-light it. Contact your dealer to organise for a replacement to be fitted before re-lighting the appliance.

## THE REMOTE CONTROL

### POSITIONING THE RECEIVER

After fitting the batteries in the receiver and the hand set, place the receiver anywhere on the hearth. There is a long lead on the receiver to allow you to position the receiver towards the front of the hearth, if you wish to see the light come on when the handset is in use. Place the lead on the hearth also. Failure to do this will cause malfunction of the unit.

### OPERATING INSTRUCTIONS FOR G30-ZRPTT REMOTE CONTROL

Caution! Read these instructions entirely before use.

G30-ZRPTT remote controls must be installed and operated according to all locally applicable regulations!

G30-ZRPTT Remote Controls are designed for use only in gas fires equipped with specially designed combination controls (GV34 or GV36 retrofitted with a motor) produced by Mertik Maxitrol. Due to the integrated thermostat, the G30-ZRPTT **is not to be used with open gas fires!**

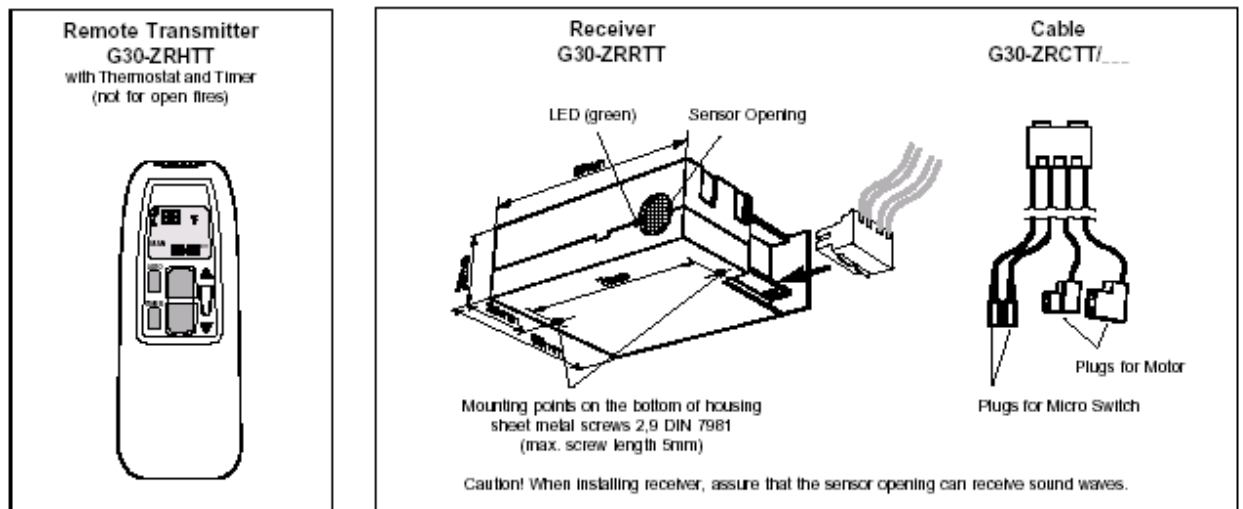

Illustration 1: Components of the Remote Package

### Technical Data

Ultrasound Transmission

Range: 1...10m 3...33ft.  
Frequency: ON 40,5kHz, OFF 40kHz

Ambient Temperature

Transmitter & Receiver max. 60°C 140°F

Batteries

Connecting Cables: max. 180°C 356°F  
Handset: 1 x 9V block (alkaline recommended)  
Receiver: 4 x 1,5V AA (alkaline recommended)

### Connections

The G30-ZRPTT is intended for use only with motorized gas combination controls models GV34 (or GV36 retrofitted with a motor). The receiver cable must be firmly plugged onto the flat blade connectors (motor: 6,3 and 4,8mm; micro switch: both 2,8mm, see Illustration 2).

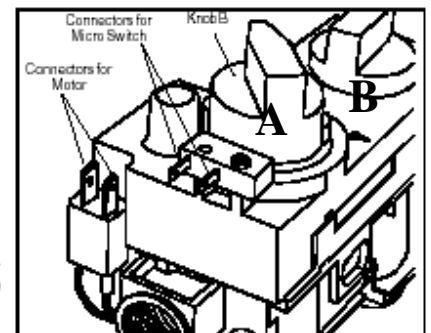

© 2007-20 Illustration 2: Cover with Connectors for Micro Switch

## Transmitter Function

### Set the Display

- After connecting the battery or by simultaneously pressing AUTO and TIMER, the display flashes. You are in set mode.
- From set mode, press AUTO to switch from °F (and 12 hour clock) to °C (and 24 hour clock) or vice versa.
- The display will automatically return to manual mode after some time, but you may immediately return to manual by depressing the TIMER button.

### Set the current Time

- After connecting the battery or by simultaneously pressing AUTO and TIMER, the display flashes. You are in set mode.
- From set mode, press (p) to set the hour and (q) to set the minute.
- Wait or press TIMER to return to “manual” mode.

### Programming the Desired Set Temperature

- Press AUTO until the display flashes.
- Press (p) or (q) to set the desired temperature.
- Wait or press AUTO to switch to automatic mode.
- A sensor in the transmitter measures the room temperature. The controller compares the room temperature with the set temperature and sends a signal to the receiver to turn the gas valve motor, which adjusts the flame height accordingly.

### Programming the Timer

- Press TIMER until P1\* flashes (period 1, heating cycle on).
- Set the time for the beginning of the first heating period by pressing (p) for hour and (q) for minute.
- Press TIMER again; P1w appears.

Illustration 2: Cover with Connectors for Micro Switch  
TIMER

AUTO

(Programming the Timer)

- Set the time for the end of the first heating period.
- Press TIMER again to set the second heating period P2\* (heat on) and P2w (heat off).
- Store both heating periods by pressing TIMER again.
- If only one heating period is desired, program the same time for P2\* and P2w.

Manual Mode (MAN in display) for Manual Flame Height Adjustment

- Press (p) to turn on the fire (main burner) or to increase flame height
- Press (q) to decrease flame or to turn down to pilot.
- To incrementally increase or decrease the flame height lightly tap either the (p) or (q) button.
- The “send” symbol appears in the upper left corner of the display when either button is depressed.

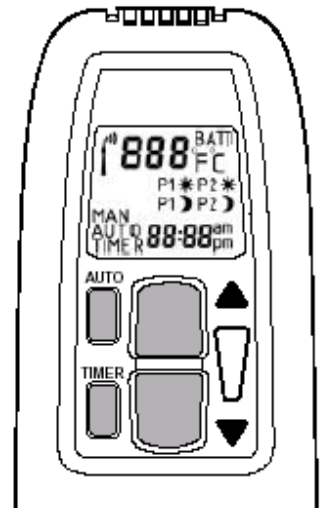

Edidin 07/2002

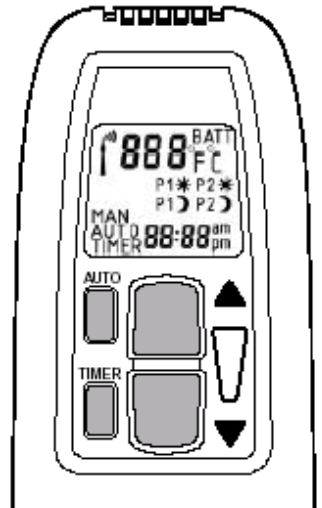

- The LED of the receiver flashes when knob B of the valve reaches its end stops.

Automatic Mode (AUTO in display) for Temperature Control

- Briefly press AUTO. The set temperature will appear briefly before the display reverts to the room temperature.

#### **Timer Mode (TIMER in display)**

- During heating periods P1\* and P2\*, the temperature is controlled in the same manner as in automatic mode.
- When the timer program turns to w (heating cycle off), the motor will turn the valve to pilot and there is no temperature control. This minimizes battery consumption.
- You may press AUTO to verify the set-temperature and then press TIMER to return to timer mode.
- You may press either the (p) or (q) button from any mode for manual override.
- To prolong battery life, we recommend switching the transmitter to manual mode and turning the fire to pilot with the (q) button before turning the appliance off. If the transmitter is left in automatic or timer mode, the batteries will continue to be used when the appliance is off.

#### **Changing the Battery**

- If BATT appears in upper right hand corner of the display or if the LED of the receiver becomes faint, please change the battery from transmitter or receiver. If the batteries lose power, the flame height can be adjusted by manually turning knob B (see illustration 2).

##### **Note**

Please note, the placement of the transmitter (temperature sensor) is important to assure proper temperature regulation. Generally, a more constant temperature will be assured, if the transmitter is not too far from the gas appliance. Before switching to AUTO or TIMER mode, press either button (p) or (q) to verify the reception (when the send symbol appears in the transmitter display, the receiver's LED must illuminate). For the AUTO or TIMER mode to function correctly, the transmitter must remain within range of the receiver. The transmitter should not be used in very close proximity to the receiver (less than 1m / 3ft) as this could, in very rare cases, produce a electronic switching error. This error could block the motor when the knob reaches the end points of its turning radius. The knob must then be turned manually to free the blockage.

The temperature is controlled by activating the motor for a specific length of time to adjust the appropriate flame height. This time is calculated by the transmitter and depends on variables such as room size, heater capacity, battery power, etc. Therefore, a few cycles are necessary before an optimum is achieved. If a low flame is sufficient to provide enough warmth to the room, then the appliance will cycle between low fire and off. This allows longer periods with the flame on and provides a more uniform room temperature.

## **10. NOTE TO THE INSTALLATION ENGINEER**

**Please make sure the customer is familiar with the initial lighting and operating procedures before leaving the site and that this instruction booklet is left with them when the final commissioning is complete.**

### **TEST FOR SPILLAGE**

A spillage test **MUST** be made before the installed fire is left with the customer.

Carry out the test by first closing all doors and windows in the room containing the fire.

Ensure that the fire is burning at full rate for a minimum of 10-15 minutes.

Using a smoke match - run along the edge of the draught diverter, leave for a further 10 minutes and repeat test.

If there is an extractor fan in a nearby room the spillage test must be repeated with the fan running and all connecting doors between the fire and fan left open.

If there are still problems, the chimney/flue may require attention. Disconnect the stove and seek expert advice.

## **11. SPILLAGE MONITORING SYSTEM**

This appliance is fitted with an atmospheric sensing spillage monitoring system, in the form of an oxygen depletion sensing pilot. This is designed to shut down the fire within a safe period if there is an excessive build up of products of combustion within the room space. This would usually only occur if the flue path suffered severe blockage, and or ventilation was severely impeded.

### **THE FOLLOWING ARE IMPORTANT WARNINGS RELATIVE TO THE SPILLAGE MONITORING SYSTEM**

- 1.** The installer must not attempt any adjustments to the spillage monitoring system.
- 2.** There must be no attempt to disable the spillage monitoring system.
- 3.** It is not possible to replace individual parts of the pilot assembly on the appliance only a complete pilot assembly (including thermocouple) may be fitted in the event of replacement being necessary. When the spillage monitoring system is replaced, only complete and original manufacturers parts may be fitted.
- 4.** Should the appliance turn itself off, wait for a minimum of 3 minutes before attempting to re-light the appliance. In the event of your stove tripping out, consult your installation engineer to have the flue/chimney checked.

## 12. TROUBLESHOOTING

### THE GAS PILOT WILL NOT IGNITE OR STAY LIT

- Ensure the gas is turned on at the appliance and the meter/cylinder.
- Hold in the pilot gas button for at least twenty seconds once the pilot is alight to ensure the operation of the safety thermocouple valve.
- Ensure that the pilot injector is not obstructed or blocked and it is free from any dust or dirt.
- Ensure that the thermocouple has not been damaged in transit. This is a very delicate device.
- On propane, check that the cylinder is not empty.

### THE PILOT IS NOT BURNING OR PERFORMING CORRECTLY

- Ensure that the aeration ring shutter on the pilot head is fully open so that the pilot flame is initially intense; this can be subsequently turned down.
- Ensure the pilot flame is the correct size for the type of gas. The flame should be focused on the thermocouple probe, so that it is evenly encircled.
- The pilot should have three flames one directed towards the thermocouple, one towards the bed of the fire and the third towards the igniter valve.
- Any whistling sound you hear is normally caused by dirt obstructing the pilot. This is normally cured by carrying out the cleaning process outlined in the next section entitled *Servicing Instructions*
- After altering the pilot, check for any leakage of gas.

### THE MAIN BURNER DOES NOT SEEM TO BURN CORRECTLY

- Ensure there is adequate gas pressure to the appliance. The pressure can be obtained by unscrewing the pressure test nipple and applying a suitable pressure gauge (i.e. a manometer). Be sure that the gas pressure agrees with the identification label on your stove.
- Ensure adequate volume of gas is being used. Once the fire is burning on maximum, turn off all other gas appliances in the house and calculate the fuel being burned from the gas meter.
- See that the burner is burning evenly across the whole of the mesh surface without any coals in place



### **13. SERVICING INSTRUCTIONS**

Servicing should be carried out annually by a qualified installation engineer when the stove is cold and the gas supply is turned off at the isolation tap. The following points should be checked

- Remove the coals and clean any dust and debris from the top of the burner unit. Ideally a vacuum cleaner should be used, but a soft brush will do.
- Check the condition of the coals. Any damaged ones will affect the efficient operation of the stove and should be replaced with new ones available from your stove supplier.
- All gas supply joints should be checked to make sure they are completely sealed and that the gas supply and pressure is to specification.
- The pilot jets are correctly set and clear of obstruction.
- The chimney should also be checked to make sure there are no restrictions or blockages.
- Finally re-lay the coals and re-light the stove as described previously.

### **AND FINALLY.**

...

We would remind you that it is a legal requirement that the stove is installed by a qualified and accredited installation engineer. Improper installation, adjustment, alteration, service or maintenance can cause personal injury and/or damage to property. If you are in the slightest doubt about any aspect of your stove's performance or you require additional information then please contact your stove supplier, a qualified installation engineer or call our technical help-line on 01743 461444

Please do not store, keep or use petrol or any other flammable liquids, vapours or substances anywhere near the stove or any other heating appliance.

We hope these instructions are clear and helpful and you are able to enjoy the full benefits of your stove. Please keep this booklet handy for future reference.

The manufacture and materials used in building your York Midi gas stove are guaranteed for one year provided the assembly and operation complies with these instructions. Accidental damage and all consumables including the glass door seals are not covered.

We are sure you will appreciate and accept that our guarantee cannot be extended to cover the actual assembly, installation and the use of your stove as these are all operations outside our control or influence. Please retain your purchase receipt. We will need to see this in the event of a claim under warranty.

# SPECIFICATION & INFORMATION

THIS SECTION TO BE COMPLETED AND SIGNED BY THE INSTALLATION ENGINEER

Type gas supply (please tick)

Natural (mains) Gas  LPG supply in bulk  LPG supply in cylinder

Size of Governor setting: (i.e.) Natural Gas 20MBAR. LPG 37MBAR

Length and size of gas supply:

Meter pressure. Fire on only:

Other appliances . All on:

Burner pressure. Fire on only:

Other appliances . All on:

Gas rate - Natural Gas - Time for 1 cubic foot in seconds:

Type and size of flue:

Approx. height: is a register plate fitted:

How much area of flue is left:

Is there any spillage: is the draught excessive:

Is there any ventilation in the room:

Has the room double glazing: is the door close fitting

Has the pilot sufficient heat to open the FFD

Is the aeration of the pilot correct:

Is the FFD Phial in the correct position in the pilot flame:

Does the flame encircle the FFD:

Installation Engineers Name:

Address

Post Code

Telephone: Fax: Mobile:

Corgi Registered: Yes  No  Number

Signed:

Date:

# *Guarantee*

Dear Customer,

Your decorative gas fire, when installed in accordance with the installation instructions and operated in accordance with these instructions should provide many years of safe and efficient operation.

We thank you for purchasing our product and trust it will provide excellent service.

This appliance carries a guarantee of 1 year. The consumable components of this appliance are guaranteed for one year.

We agree to repair free of charge or, at our option, replace the appliance or part thereof, which may prove to be defective within the guarantee period.

The guarantee is void if:

- The appliance is not installed and operated in accordance with our instructions; or
- The appliance is not serviced, by a CORGI registered engineer, annually; or
- Repairs of modification have been carried out by the purchaser or any third party not authorized by us; or
- The appliance has been misused or accidentally damaged; or
- Damage is due to 'fair wear and tear'; or
- The appliance or defective component(s) are not returned to us, prepaid postage.

The rights given in this guarantee are limited to the UK mainland and are in addition to any to which you may have a statutory entitlement.

Please retain your purchase receipt. We will need to see this in the event of a claim under warranty.

Broseley Fires Ltd  
Knights Way  
Battlefield Enterprise Park  
Shrewsbury  
SY1 3AB  
Telephone + 44 (0) 1743 461 444  
Fax + 44 (0) 1743 461 446