

VERINE

FIRES ✦ TO ✦ INSPIRE

# Meridian MK2

**BALANCED FLUE LOG EFFECT GAS FIRE**

**Installation, Maintenance & User Instructions**

**Hand these instructions to the user**

**Model No's NBFL\*\*RN2 is only for use on Natural Gas (G20) at a supply pressure of 20 mbar in G.B. / I.E.**

**\*\* denotes cosmetic variant**

# CONTENTS

		PAGE
<b>Section 1</b>	<b>Information and Requirements</b>	
1.0	Appliance Information	3
1.1	Conditions of Installation	4
1.2	Fireplace surround & suitability	4
1.3	Flue Terminal Position	5
1.4	Shelf position	6
1.5	Hearths	6
<b>Section 2</b>	<b>Installation of Fire</b>	
2.1	Unpacking the fire	6
2.2	Fireplace opening	7-8
2.3	Preparation of the wall	8-9
2.4	Preparation of the flue hole	9
2.5	Installation of the gas supply	10
2.6	Preparation of the flue duct	11
2.7	Securing the firebox to the opening	12-13
2.8	Making the gas connection / pressure testing	13
2.9	Fitting the terminal guard	13
2.10	Removal & refitting of the glass frame	14-16
2.11	Fitting the batteries to the receiver and handset	17
<b>Section 3</b>	<b>Assembling Fuel Bed and Commissioning</b>	
3.1	Fitting the log fuel bed	18-22
3.2	Lighting the appliance	23-24
3.3	Removal & re-fitting the fascia assembly & cosmetic trim	25
<b>Section 4</b>	<b>Maintenance</b>	
4.1	Removal of the burner assembly	27
4.2	Removal of the gas valve	27
4.3	Removal of the pilot assembly	28
4.4	Removal of the receiver	28
	Parts shortlist	29
<b>Section 5</b>	<b>User Instructions</b>	
5.1	Installation Information / about your fire	30-31
5.2	Operating your fire	32-33
5.3	Removal / replacing the glass frame	34-35
5.4	Removal / replacing the log fuel-bed	36-40
5.5	Cleaning instructions	40-41
5.6	Replacement of batteries in the receiver and handset	41
5.7	Removal & re-fitting the fascia assembly & cosmetic trim	42
	User replaceable parts	43

This appliance is manufactured by :-

BFM Europe Ltd.  
Trentham Lakes,  
Stoke-on-Trent, ST4 4TJ.

## SECTION 1 INFORMATION AND REQUIREMENTS

### 1.0 APPLIANCE INFORMATION

Model	NBFL**RN2
	** denotes cosmetic variant of product
Gas Type	G20
Main injector (1 off)	Size 380
Pilot Type	Black Technigas "Polodoro" G27.2
Max. Gross Heat Input :	5.7 kW
Min. Gross Heat Input :	4.4 kW
Gas Rate :	0.529 m <sup>3</sup> /hr
Cold Pressure :	20.0 +/-1.0 mbar
Ignition :	6V Battery Ignition
Electrode Spark Gap	4.0mm
Packed Weight	30 kg
Gas Connection :	8mm Compression (supplied with fire)

**Fig. 1**

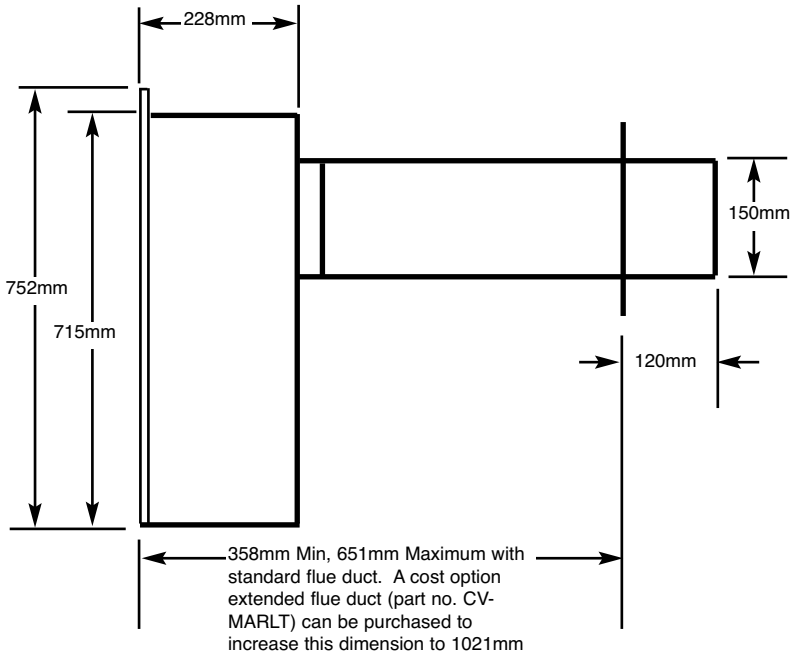

## INSTALLATION REQUIREMENTS

### Efficiency Declaration

The efficiency of this appliance has been measured as specified in BS EN 613 : 2001 and the result after conversion to Gross using the appropriate factor from Table 4 of SAP 2009 is 76%. The test data from which it has been calculated has been certified by BSI. The efficiency value may be used in the UK Government's Standard Assessment Procedure (SAP) for energy rating of dwellings.

### 1.1 CONDITIONS OF INSTALLATION

It is the law that all gas appliances are installed only by a GAS SAFE Registered Installer, in accordance with these installation instructions and the Gas Safety (Installation and Use) Regulations 1998 as amended. Failure to install appliances correctly could lead to prosecution. It is in your own interest and that of safety to comply with the law.

The installation must also be in accordance with all relevant parts of the Local and National Building Regulations where appropriate, the Building Regulations (Scotland Consolidation) issued by the Scottish Development Department, and all applicable requirements of the following British Standard Code of Practice.

1. B.S. 5871 Part 1 Installation of Gas Fires
2. B.S. 6891 Installation of Gas Pipework
3. B.S. 5440 Parts 1 & 2 Installation of Flues and Ventilation
4. I.S 813 : 1996 Domestic Gas Installation, issued by the National Standards Authority of Ireland.

### 1.2 FIREPLACE / SURROUND SUITABILITY

This product is designed to fit fireplaces with a minimum 1" / 25mm rebate. The fire must only be installed on a hearth it **must not be installed directly onto carpet or other combustible floor materials**. The fire is suitable for fitting to non-combustible fire place surrounds and proprietary fire place surrounds with a temperature rating of at least 150 degrees celcius (Class "O").

**Soft wall coverings such as blown vinyl, wall paper etc. could be affected by the rising hot air and scorching and/or discoloration may result. Due consideration should be made to this when installing or decorating.**

### 1.3 FLUE TERMINAL POSITION

The minimum acceptable dimensions from the flue terminal to obstructions and ventilation openings are shown below and listed in the table. It is important that the position of the flue allows the free passage of air across it at all times. The minimum acceptable space from the flue terminal to obstructions and ventilation openings are specified below (Fig. 2)

Fig. 2

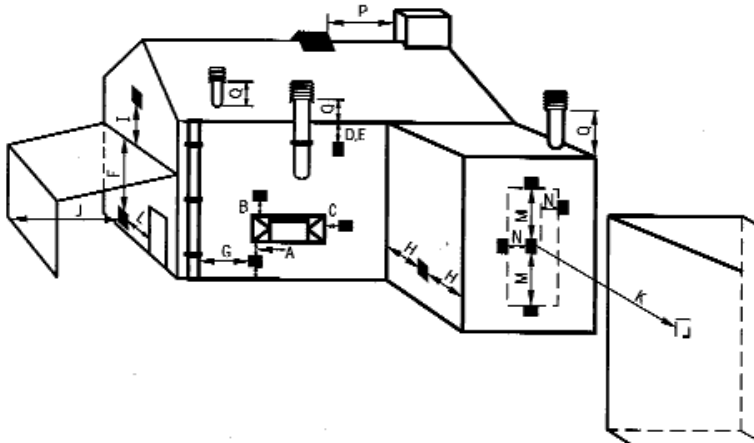

DIMENSION	TERMINAL POSITION	MINIMUM DIMENSION
A	Directly below an opening, air brick, opening window	300mm (12in)
B	Above an opening, air brick, opening window	300mm (12in)
C	Horizontally to an opening, air brick, opening window etc.	300mm (12in)
D	Below gutters, soil pipes or drain pipes	300mm (12in)
E	Below eaves	300mm (12in)
F	Below balconies or car port roof	600mm (24in)
G	From a vertical drain pipe or soil pipe	300mm (12in)
H	From an internal or external corner	600mm (24in)
I	Above ground roof or balcony level	300mm (12in)
J	From a surface facing the terminal	600mm (24in)
K	From a terminal facing the terminal	600mm (24in)
L	From an opening in the car port	1200mm (48in)
M	Vertically from a terminal on the same wall	1500mm(59in)
N	Horizontally from a terminal on the same Wall	300mm (12in)
O	NOT APPLICABLE	N/A
P	NOT APPLICABLE	N/A
Q	NOT APPLICABLE	N/A

## **1.4 SHELF POSITION**

The fire may be fitted below a combustible shelf providing there is a minimum distance of 200mm above the top of the fire and the shelf does not project more than 150mm. If the shelf overhangs more than 150mm the distance between the fire and the shelf must be increased by 15mm for every 25mm of additional overhang over 150mm.

## **1.5 HEARTHES**

This appliance must only be installed on to a concrete or non-combustible hearth. The hearth material must be a minimum thickness of 12mm with the top surface at least 50mm above the floor. The hearth must be fitted symmetrically about the fire opening and have a minimum width of 900mm and a minimum projection of 300mm forwards from the fire opening.

# **SECTION 2 INSTALLATION OF FIRE**

## **2.1 UNPACKING THE FIRE**

Carefully lift the fire out of the carton. Remove the loose item packaging carefully from the front of the appliance. Check the contents as listed :-

### Packing Check List - All Models

- 1 off Firebox / burner assembly
- 1 off Boxed ceramic log effect fuel-bed (packed inside combustion chamber)
- 1 off Cosmetic trim
- 1 off Loose items bag inc handset, 4 off 1.5V batteries & 1 off 9V battery
- 1 off Flue terminal / pipe unit
- 1 off Flue terminal guard
- 1 off Fascia (colour / finish dependent upon model chosen)
- 1 off Installation / user book (combined)
- 1 off Length of aluminium foil tape (packed in loose items pack)

## 2.2 FIRE PLACE OPENING

- 2.2.1 The front opening of the fire place must be between 550 and 565mm wide, and between 720 and 730mm high. If the opening exceeds these dimensions then a surround must be constructed from suitable non-combustible material to produce a suitable sized opening. Any surround must be suitably sealed to the fire place to prevent leakage. See fig. 3 below

**Fig. 3**

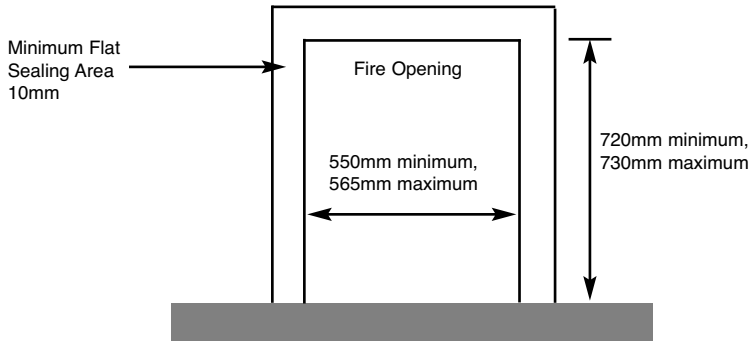

- 2.2.2 The minimum / maximum sized distances between the firebox mounting flange and outside wall are shown below in Fig. 4

**Fig. 4**

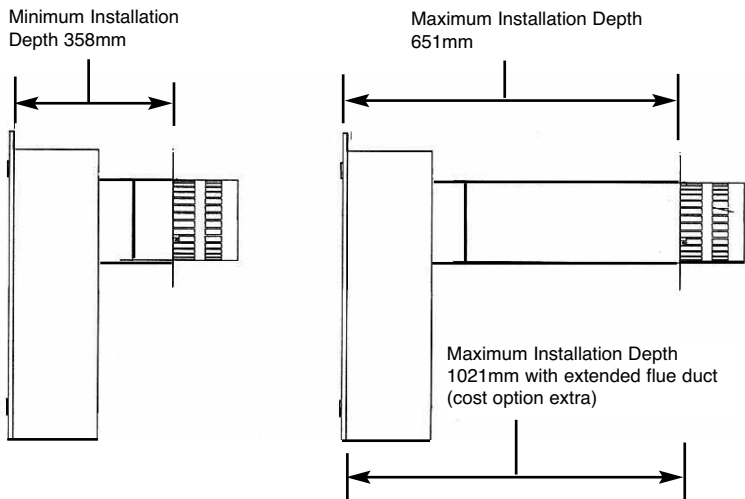

2.2.3

**NOTE : WHEN MEASURING LENGTH BETWEEN FIREBOX AND THE OUTER WALL TAKE INTO ACCOUNT THE REBATE ON ANY FALSE CHIMNEY BREAST, SURROUND OR BOTH THAT IS TO BE USED**

Fig. 5

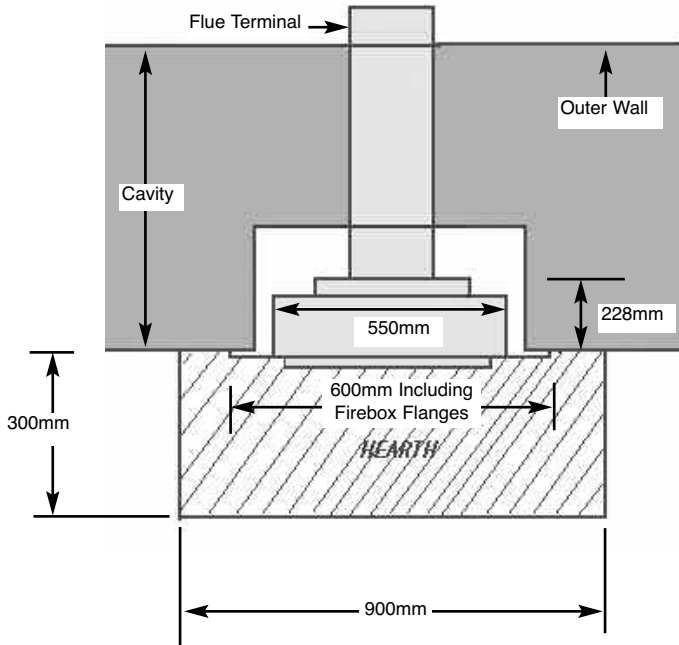

2.2.4

The appliance must be fitted into a fireplace or false chimney constructed of non-combustible materials, minimum width 550mm, minimum height 720mm.

**2.3 PREPARATION OF THE WALL**

2.3.1

The appliance and flue pipes must be installed at right angles to the mounting wall. The appliance itself should be installed vertically against a flat wall. Where an uneven wall surface is found, appropriate action should be taken to ensure that the appliance is not stressed or does not distort when installed.

Ensure that the floor surface onto which the appliance is mounted onto is flat. The minimum height from the floor to the centre of the flue is shown on fig. 6 overpage.



**Fig. 6**

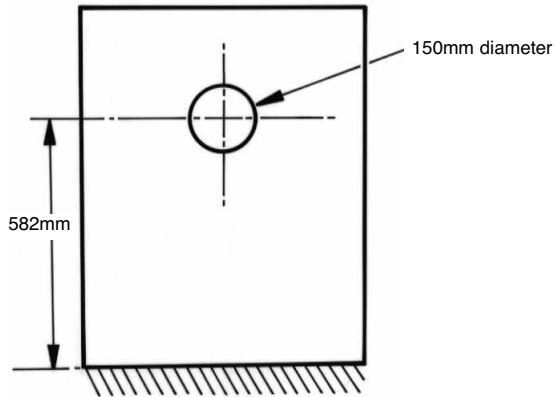

## **2.4 PREPARATION OF THE FLUE HOLE**

2.4.1 Mark the position of the centre of the flue on the inner wall.

2.4.2 Cut hole for outer flue pipe. There are two possible methods to achieve this, either core drill or via hammer and chisel.

2.4.3 To core drill, proceed as follows :-

Drill a pilot hole through the wall, in position as specified in figure 6.

Using a 6" core drill, drill the flue hole.

To Hammer and chisel, proceed as follows :-

Mark the position of the centre of the flue pipe as specified in figure 6.

Mark the position of the hole around this point.

Chisel out the area as marked on the wall.

2.4.4 We then recommend that a cardboard cylinder is placed around the flue pipe and inserted in the chiselled out hole whilst making good.

### **NOTE :-**

**If the appliance is to be installed into a building under construction, it is recommended that a non-corrosive metal tube of 6" diameter be inserted into the position of the hole.**

## 2.5 INSTALLATION OF THE GAS SUPPLY

2.5.1 Before installing the firebox, decide from which side or if a rear connection to the gas supply is required. Plan the pipe run to enter the firebox from the left, right or rear and connect to the inlet elbow. See below :-

2.5.2 If concealed pipe work is required plan the pipe run to enter the fire box through the openings in the rear of the fire box and connect to the inlet elbow. See Fig. 7 & 8 below for a suggested concealed pipe layout.

Fig. 7

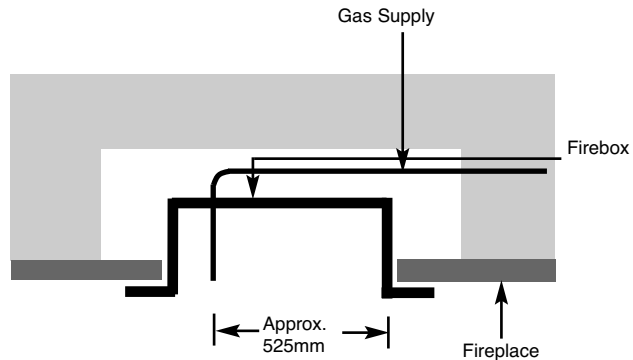
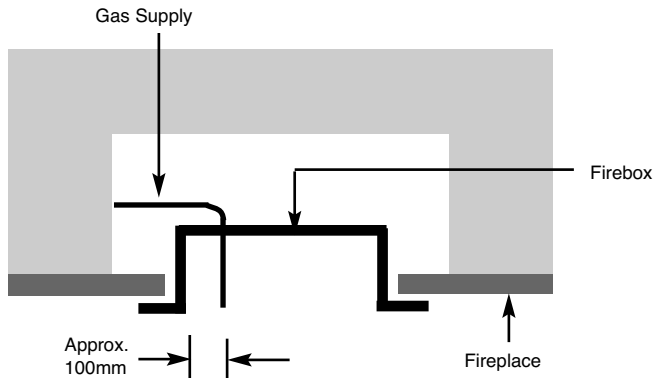

Fig. 8



**Note :** Before breaking into the gas supply a pressure drop test should be carried out to establish that the existing pipework is sound. Always re-fit the gas inlet plate to the rear entry point and secure with the screws provided.

## 2.6 PREPARATION OF THE FLUE DUCT

- 2.6.1 Place the firebox into the fire opening with fire surround correctly secured in the final position. From the outside of the house measure from the face of the outside wall to the rear panel of the firebox through the flue hole. Cut the flue duct to this size.

### IMPORTANT : ENSURE THE PIPES ARE CUT SQUARELY.

- 2.6.2 The joint between the firebox and the flue duct as shown below in Fig. 9 must be secured with screws and sealed with the foil tape as supplied. In order to do this, the wall plate must be removed from the flue pipe / termination.

Fig. 9

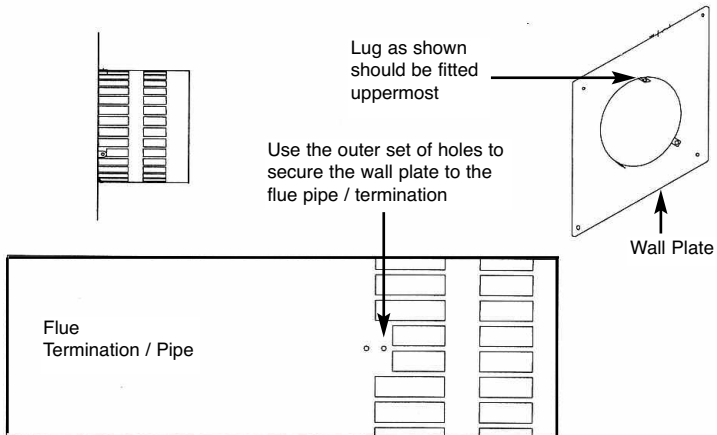

- 2.6.3 Due to the varying lengths of flue that will be required via differing installations it will be necessary to drill the flue pipe using the 3 off holes in the mounting flange on the rear of the combustion chamber as a guide for positioning. When the holes have been drilled and the screws fitted, wrap the joint with the foil tape supplied.
- 2.6.4 Re-fit the wall plate ensuring the outer set of holes as indicated above in Fig. 9 are used. Use a high temperature sealant to secure the wall plate to the outside wall of the property before securing with the screws and rawplugs supplied to ensure a mechanical fix.

## 2.7 SECURING OF FIREBOX TO THE OPENING

2.7.1 There is a choice of methods of fixing the firebox that are provided to enable the installer to deal with any type of installation. The preferred method of fixing the appliance is the cable fixing method, which is described in detail in the following section.

2.7.2 If the standard firebox fixing flange is to be used, the firebox may be secured using the cable method, but in installations where the cable method is not suitable, e.g. insufficient space behind the firebox, or loose masonry, the firebox can be fitted directly to either the front of the fireplace via the flange with the four off screws provided. The firebox will require sealing to the fireplace, regardless of the method used.

2.7.3 To secure the fire using the preferred cable method, proceed as follows below :-

2.7.4 Mark out and drill 4 off No 14 6mm holes in the rear face of the fire opening in the positions as shown in Fig. 10 below.

**Fig. 10**

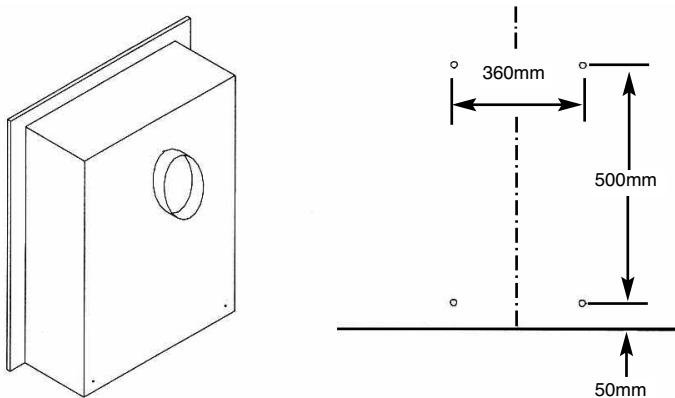

2.7.5 Fit the wall plugs provided and screw the fixing eyes securely into the rear of the fire opening. Remove the glass frame and burner assembly as detailed in section 2.10 / 2.11.

2.7.6 Uncoil the two fire fixing cables and thread one end of the each of the cables through the ears in the top of the fire box lid, and through each fixing eye at the top. Thread both cables through the fixing eye's at the bottom, then the holes at the bottom of the firebox

2.7.7 Thread the cables through the rear of the firebox, insert the flue pipe / terminal through the hole in the rear of the opening and offer the firebox up to the fireplace.

- 2.7.8 Thread a tensioning screw over both of the cables and ensure that the tensioning nut is screwed fully up against the hexagon shoulder of the tensioning screw (this provides maximum travel for the tensioning nut).
- 2.7.9 Fit a screwed nipple on to each of the cables and pull hand tight up against the tensioning screw, then secure each nipple with a screwdriver.
- 2.7.10 Before making the final gas connection, thoroughly purge the gas supply pipework to remove all foreign matter, otherwise serious damage may be caused to the gas control valve on the fire.  
**Failure to purge the gas supply will invalidate the guarantee.**

## **2.8 MAKING THE GAS CONNECTION / PRESSURE TESTING**

- 2.8.1 The gas connection should be made to the appliance inlet elbow to using 8mm rigid tubing.
- 2.8.2 Remove the pressure test point screw from the inlet elbow and fit a manometer.
- 2.8.3 Turn on the main gas supply and carry out a gas tightness test.
- 2.8.4 Light the fire (see pages 19-20 for instructions).
- 2.8.5 Check that the gas pressure is **20.0 mbar (+/- 1.0mbar) 8.0 in w.g.(+/- 0.4 in w.g.)**. Turn off the fire, remove the manometer and refit the pressure test point screw. Check the pressure test point screw for gas tightness with the appliance turned on using a suitable leak detection fluid or detector.

## **2.9 FITTING THE TERMINAL GUARD**

- 2.9.1 With the flue terminal in position, place the terminal guard over the top of the flue terminal and mark the position of the holes on the outer wall.
- 2.9.2 Remove the terminal guard and drill the 4 off 6 mm holes.
- 2.9.3 Insert the raw plugs into the drilled holes, replace the terminal guard over the top of the flue terminal and attach to the wall using the No.12 x 40mm screws provided with the terminal guard.

**NOTE : In England & Wales, building regulations require that a terminal guard should be fitted if the terminal could come into contact with people near the building or be subject to damage. BFM Europe Ltd. also recommend the fitting of a flue terminal guard where regulations do not demand that it be fitted. A suitable flue terminal guard is supplied with the appliance.**

## 2.10 REMOVING & REFITTING OF THE GLASS FRAME.

- 2.10.1 Remove the glass panel by undoing the retaining clips at the base of the glass frame as shown below in Fig. 11

**Fig. 11**

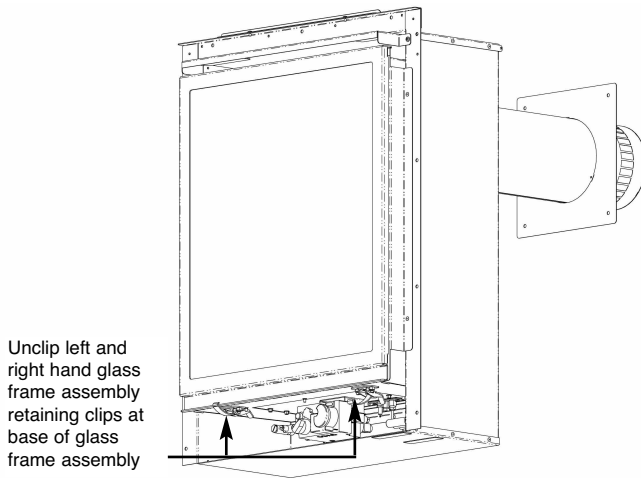

- 2.10.2 Remove the glass frame assembly by tilting forwards then lifting as shown in Fig. 12 below. Re-assemble in reverse order, ensuring a consistent seal between the combustion chamber and glass frame.

**Fig. 12**

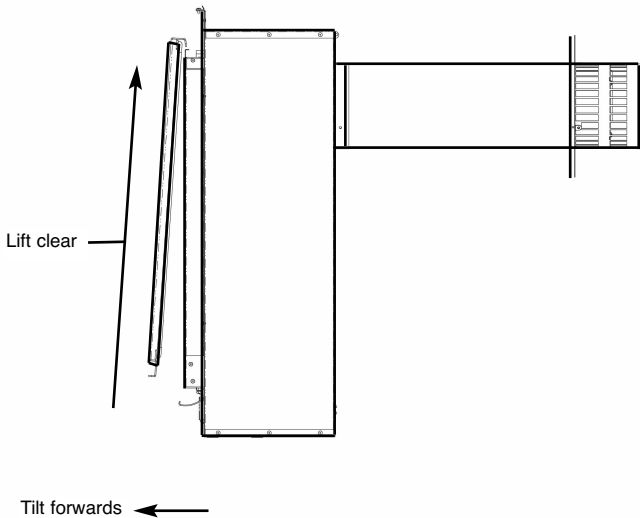

## 2.11 REMOVAL OF THE BURNER ASSEMBLY

- 2.11.1 Remove the burner. To allow burner removal, the ceramic support panel must be removed to allow access to the burner fixings. Remove the 4 off ceramic support retaining screws as shown below in Fig. 13

Fig. 13

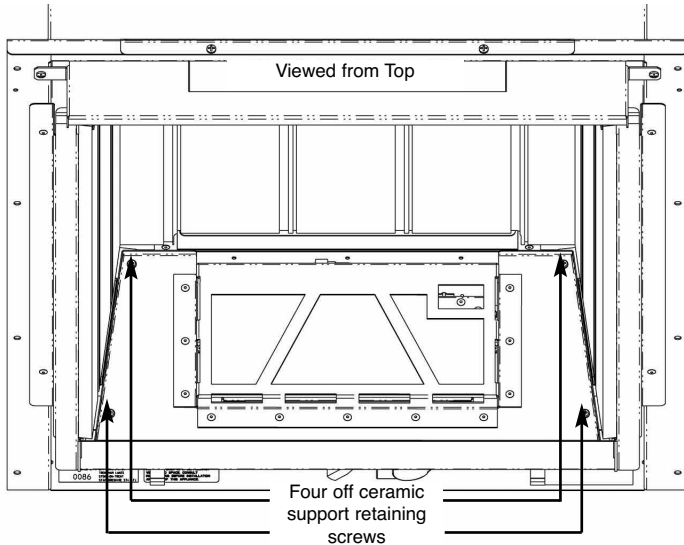

- 2.11.2 Remove the 7 off screws that hold the burner in position, see Fig. 14 below.

Fig. 14

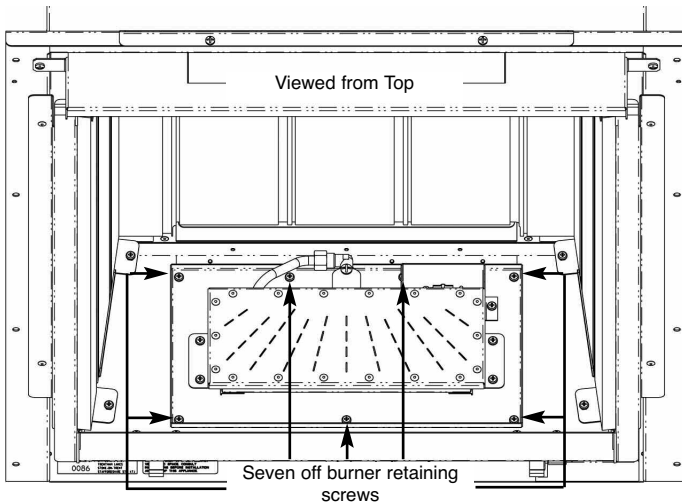

- 2.11.3 Remove the burner by lifting clear from the combustion chamber as shown below in Fig. 15, take care to also lift out the receiver unit and wiring loom, (the receiver unit is held in position with velcro).

**Fig. 15**

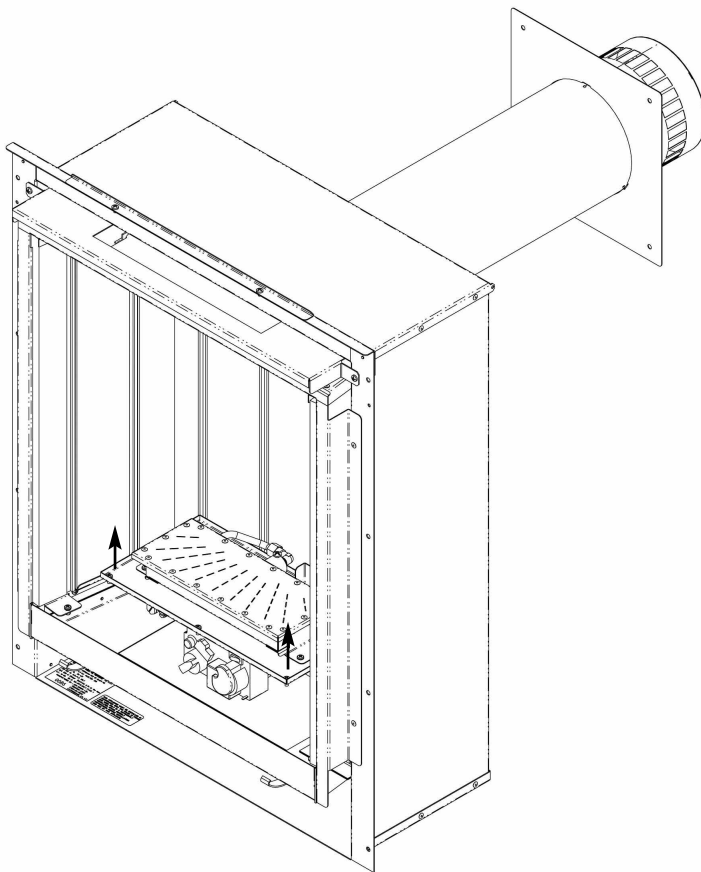

- 2.11.4 Store the burner unit in a safe position.

- 2.11.5 Re-assemble in reverse order.



## **2.12 FITTING THE BATTERIES TO THE RECEIVER UNIT & HANDSET**

- 2.12.1 4 off AA 1.5V batteries (found in the loose items pack) are to be fitted to the battery holder located on the base of the fire below the combustion chamber.
- 2.12.2 To remove the receiver unit, remove it from the velcro strips with which it is secured.
- 2.12.3 Slide off the cover from the receiver unit.
- 2.12.4 Fit the 4 off AA batteries to the unit, then re-fit the cover.
- 2.12.5 Replace the receiver into it's velcro strips at the base of the fire.
- 2.12.5 Fit the 1 off 9V battery to the handset by removing the rear cover, connecting the battery then replacing the cover.

## SECTION 3

### 3.1 ASSEMBLING THE LOG FUEL-BED

- 3.1.1 Place the L/H and R/H ceramic base pieces onto the ceramic support panel as shown below in Fig. 16

Fig. 16



- 3.1.2 Place the front ceramic base piece onto the ceramic support ensuring the location tabs fit into the L/H & R/H ceramic base pieces as shown below in Fig. 17

Fig. 17



- 3.1.3 Place the base log onto the ceramic support panel as shown below in Fig. 18, ensuring the spacer locating blocks on the rear face are fitted flush up against the rear panel.

**Fig. 18**

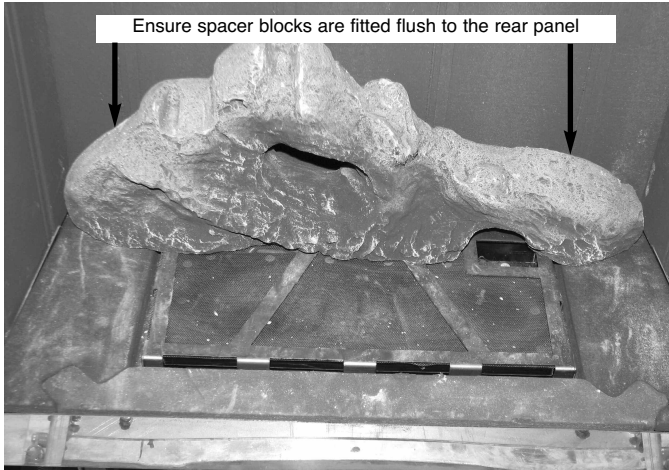

- 3.1.4 Cover the burner and fuel-bed base ceramic in a single, even layer of bark chippings as shown below in Fig. 19

**Fig. 19**



3.1.5 Position log “H” onto the base log using the location lug on the back face of log “H” and the groove on the base log to find the correct location, as shown below in Fig. 20

**Fig. 20**



3.1.6 Position log “E” onto the base log using the location lug on the back face of log “E” and the groove on the base log to find the correct location as shown below in Fig. 21

**Fig. 21**

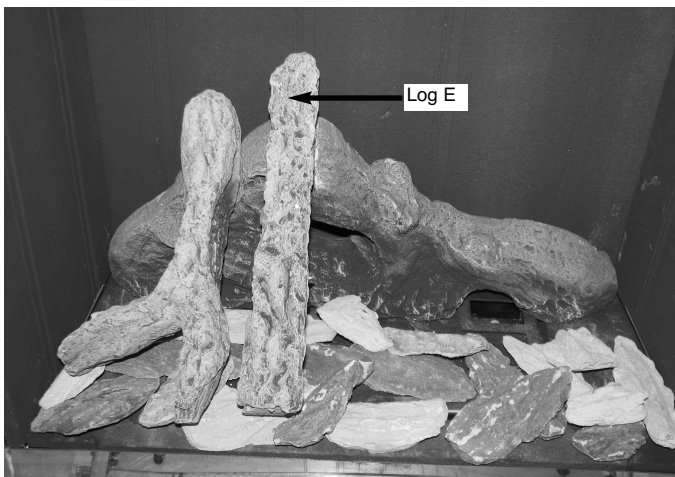

3.1.7 Position log “B” onto the base log using the location lug on the back face of log “B” and the groove on the base log to find the correct location as shown below in Fig. 22

**Fig. 22**



3.1.8 Position log “G” onto the base log using the location lug on the back face of log “G” and the groove on the base log to find the correct location as shown below in Fig. 23

**Fig. 23**



3.1.9 Re-fit the glass frame assembly as shown on page 14 before proceeding to section 3.2

**Warning : Use only the log fuel-bed supplied with the fire. When replacing the log fuel-bed remove the old log fuel-bed and discard it. Fit a complete log fuel-bed from the manufacturer, only use genuine replacements.**

**THE FOLLOWING STATEMENT IS APPLICABLE TO ALL FUEL-BED TYPES**

**This appliance uses fuel effect pieces containing Refractory Ceramic Fibres (R.C.F.), which are man-made vitreous silicate fibres. Excessive exposure to these materials may cause temporary irritation to eyes, skin and respiratory tract. Consequently, it makes sense to take care when handling these articles to ensure that the release of dust is kept to a minimum. To ensure that the release of fibres from these R.C.F. articles is kept to a minimum, during installation & servicing we recommend that you use a HEPA filtered vacuum to remove any dust and soot accumulated in and around the fire, before and after working on the fire. When replacing these articles we recommend that the replaced items are not broken up, but are sealed within a heavy duty polythene bag, clearly labelled as “RCF waste”. This is not classified as “hazardous waste” and may be disposed of at a tipping site licensed for the disposal of industrial waste. Protective clothing is not required when handling these articles, but we do recommend you follow the normal hygiene rules of not smoking, eating or drinking in the work area, and always wash your hands before eating or drinking.**

**This appliance does not contain any component manufactured from asbestos or asbestos related products.**

## 3.2 LIGHTING THE APPLIANCE

- 3.2.1 The control valve is positioned centrally below the burner unit of the fire when viewed from the front.
- 3.2.2 To operate the appliance automatically via the remote control handset, ensure that the on / off switch is switched to the “on” position as shown below in Fig. 24

**Fig. 24**

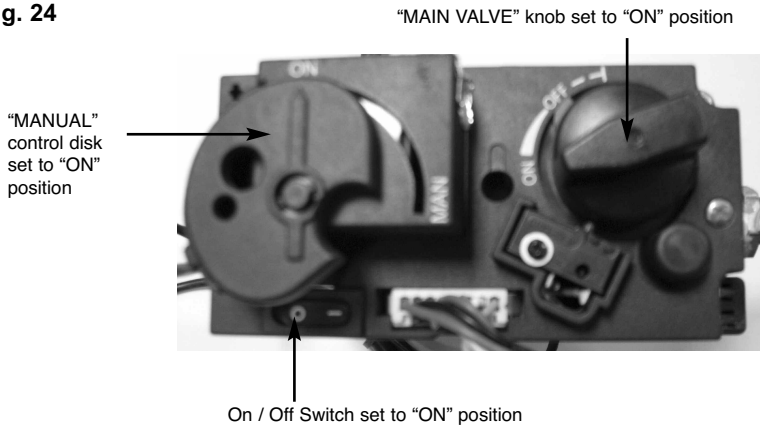

- 3.2.3 Switch the MANUAL control disc to the “on” position, (as shown above in Fig. 24)
- 3.2.4 Switch the main valve knob to the “ON” position. (as shown above in Fig. 24)
- 3.2.5 Press and hold the “STAR” button and “UP” button on the remote handset simultaneously, see Fig. 25 overpage for image of handset.
- 3.2.6 The valve will then emit an audible beep and commence its ignition sequence. When the pilot flame has been established, the control will continue to beep whilst the thermocouple heats up. When the thermocouple has reached operating temperature, it will allow gas to flow to the burner and the burner will light at high rate heat input (5.7kW).

3.2.7 The fire can now be switched between HIGH rate heat input and LOW rate heat input by pressing the “DOWN” arrow on the handset. To reduce the flame height of the main burner incrementally, press the arrow momentarily. To reduce the heat input directly down to the minimum level, press the “SMALL” flame arrow on the handset twice, NOTE : The flame will go to HIGH rate heat input before going to designated LOW rate heat input. To return back to HIGH rate heat input press the “LARGE” flame button twice. To put the fire in In “STANDBY MODE” (only the pilot remains lit) press and hold the “SMALL” flame arrow on the handset.

**AFTER THE PILOT FLAME HAS BEEN EXTINGUISHED, IF YOU WISH TO RE-LIGHT THE APPLIANCE YOU MUST WAIT AT LEAST THREE MINUTES BEFORE TRYING TO RE-LIGHT THE FIRE.**

3.2.8 Should the handset be misplaced, you can turn the fire off by switching the “ON / OFF” switch to the “OFF” position.

**Fig. 25**

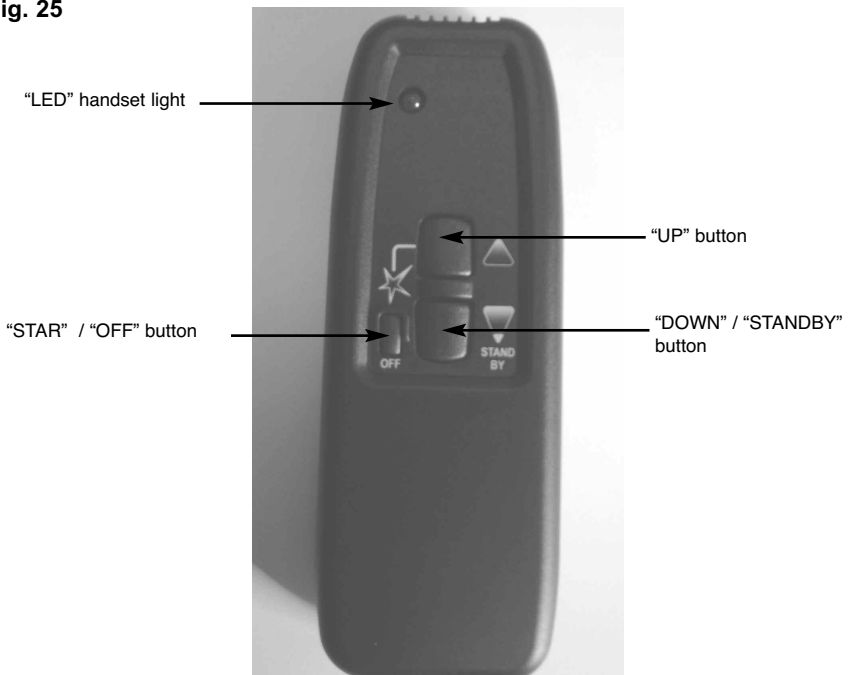



### 3.3 REMOVING / RE-FITTING THE FASCIA ASSEMBLY & COSMETIC TRIM

- 3.3.1 The trim is secured by hooking the trim over the bracket on the top flange of the firebox as shown below in Fig. 26. The bracket is adjustable to ensure the fit is correct.

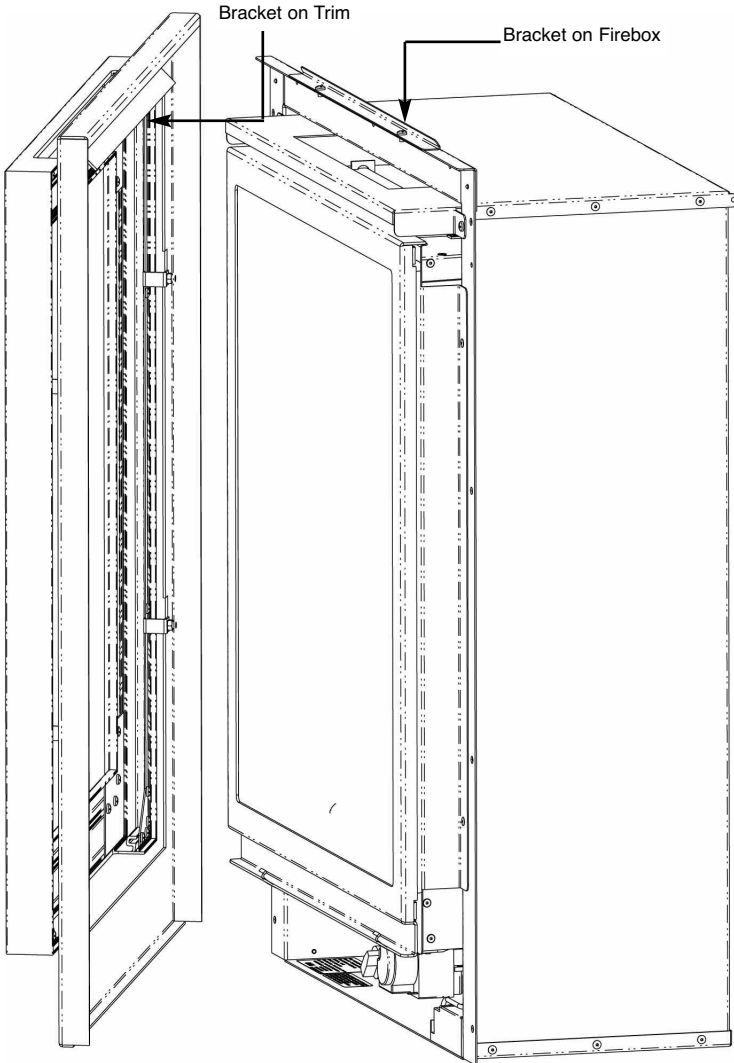

3.3.2 Fit the cosmetic trim over the top edge of the glass frame assembly as shown below in Fig. 27 and secure with 2 screws.

**Fig. 27**

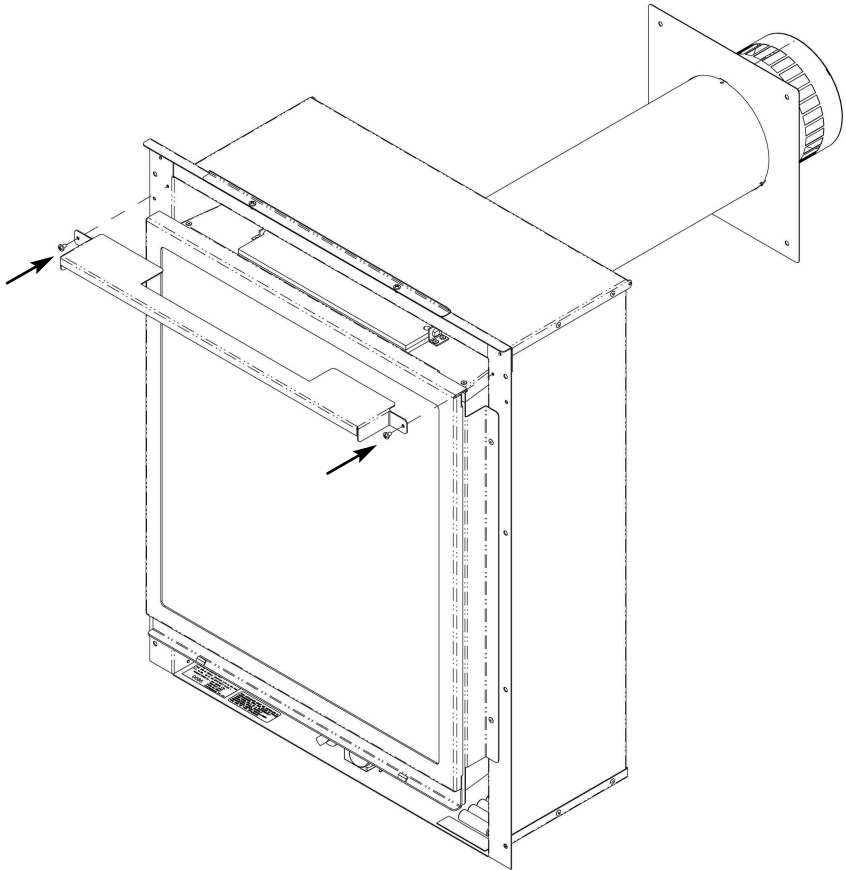

## **SECTION 4 MAINTENANCE**

**Servicing should be carried out annually by a competent person such as a GAS SAFE registered engineer. It is a condition of the Verine guarantee schemes that this is carried out by a competent person i.e a GAS SAFE registered Engineer in accordance with these servicing notes and that the thermocouple is changed as a condition of the guarantee.**

The condition of the logs should be checked and **if necessary the whole set should be replaced with a genuine replacement set.**

The burner assembly is designed to be removed as a complete unit for ease of access. **After any servicing work a gas tightness check must always be carried out.**

### **For Diagrams refer to Section 2**

#### **4.1 Removing the burner assembly from the fire.**

4.1.1 Prepare work area (lay down dust sheets etc.)

4.1.2 Remove the fascia. Remove the glass assembly, remove the ceramic logs.

4.1.3 Isolate the gas supply and remove the supply pipe from the appliance inlet elbow. Unscrew and remove the four screws which retain the ceramic support plate to the base, then lift clear. Remove the seven screws which hold the burner in position & then remove the burner assembly from the fire.

4.1.4 To refit the burner assembly, locate the burner unit and refit the seven screws. Refit the ceramic support plate and four screws. Refit the gas supply pipe and carry out a gas tightness test. Refit the fuel-bed referring to section 3 for the correct log positions. The fascia and cosmetic fascia can now be re-fitted.

#### **4.2 Removing the Gas Control Valve**

4.2.1 Remove the burner assembly as detailed in section 4.1

4.2.2 Remove the thermocouple retaining nut from the valve, remove the main pipe, inlet pipe, pilot pipe and thermocouple interrupter / wires from the valve.

4.2.3 Remove the valve retaining screws and remove the valve. Re-assemble in reverse order and carry out a gas tightness test.

### **4.3 Removing the Pilot Assembly.**

- 4.3.1 Prepare work area (lay down dust sheets etc.)
- 4.3.2 Remove the trim from the product and put it in a safe location.
- 4.3.3 Remove the glass frame assembly as shown in section 2.10 and put it in a safe location.
- 4.3.4 Loosen the pilot nut and remove the two screws retaining the pilot assembly. Unscrew the thermocouple from the gas valve.
- 4.3.4 Re-assemble in reverse order and carry out a gas tightness test.

### **4.4 Replacing the Radio Frequency Receiver or its Batteries**

- 4.4.1 Prepare work area (lay down dust sheets etc.)
  - 4.4.2 Remove the trim from the product and put it in a safe location.
  - 4.4.3 The RF receiver is located on the combustion chamber base on the R/H/S of the product, below the burner assembly. Remove the RF receiver (held in position with velcro). Slide the battery cover off and replace the batteries as necessary, if replacing disconnect the wiring looms. Re-assemble in reverse order.
  - 4.4.4 Replace in reverse order and check correct operation of the appliance.
  - 4.4.5 The fascia can now be re-fitted.
- NB The handset uses one LR61 (9v) and should be replaced by removing the cover on the rear of the handset.

**ENSURE THE BATTERIES ARE CONNECTED TO THE CORRECT POLARITY  
POSITIVE (+), NEGATIVE (-)**

## PARTS SHORTLIST

Replacement of any other parts must be carried out by a competent person such as a GAS SAFE registered gas installer. The part numbers of the main replaceable parts are as follows, these are available from your local Verine stockist, whose details can be found on the BFM Europe website, in the “stockist” section.

Gas Control Valve	B-92200
Handset	B-159250
Receiver	B-153140
Ignition Lead	B-50380
Thermocouple Interupter	B-93310
On / Off Switch & Supply Wires	B-93320
Meridian glass seal	B-139420
Meridian glass panel	CV-102111
Meridian glass frame assembly	1133-139410
Meridian base fibre centre section	B-137240
Meridian fibre right hand section	B-141710
Meridian fibre left hand section	B-141720
Meridian set bark chippings	B-142900
Meridian rear log	B-142130
Meridian complete log set	B-142120
Meridian log “B” only	B-134080
Meridian log “E” only	B-134110
Meridian log “G” only	B-134130
Meridian log “H” only	B-134140
Meridian BF NG pilot assy	CV-104530
800mm extended flue duct	CV-MARLT

## SECTION FIVE - USER INSTRUCTIONS

### 5.1 INSTALLATION INFORMATION

#### Conditions of Installation

It is the law that all gas appliances are installed only by a competent (e.g. GAS SAFE) Registered Installer, in accordance with the installation instructions and the Gas Safety (Installation and Use) Regulations 1998. Failure to install appliances correctly could lead to prosecution. It is in your own interest and that of safety to comply with the law.

The fire may be fitted below a combustible shelf provided that the shelf is at least 200mm above the top of the appliance and the depth of the shelf does not exceed 150mm.

The fire may be installed below combustible shelves which exceed 150mm deep providing that the clearance above the fire is increased by 15mm for each 25mm of additional overhang in excess of 150mm.

**No purpose made additional ventilation is normally required for this appliance when installed in G.B. When installed I.E. please consult document I.S. 813 : 1996 Domestic Gas Installation which is issued by the National Standards Authority of Ireland. Any purpose made ventilation should be checked periodically to ensure that it is free from obstruction.**

If the chimney or flue has been previously used by appliances burning fuels other than gas they must be swept prior to the installation of this fire.

If this appliance is fitted directly on to a wall without the use of a fireplace or surround, soft wall coverings such as wallpaper, blown vinyl etc. could be affected by the heat and hot air and may discolour or scorch. This should be considered when installing or decorating.

The Model number of this appliance is as stated on the rating plate affixed to the control panel of the fire and the appliance is manufactured by:-

BFM Europe Ltd.  
Trentham Lakes  
Stoke on Trent  
ST4 4TJ

**Please Note : The life span of the batteries in the burner unit on remote and electronic fire control models is dependent upon use and therefore the battery life will vary accordingly. If the burner unit fails to operate, please check the 6 off AA batteries before calling the service centre for engineer assistance.**

## **About your Verine Meridian**

The Verine Meridian range of log effect gas fires incorporates a unique and highly developed fuel bed which gives the realism of a loose log layout combined with realistic flames and glow. The use of durable ceramic material in the construction of the fuel-bed components ensures long and trouble free operation.

Please take the time to fully read these instructions as you will then be able to obtain the most effective and safe operation of your fire.

## **IMPORTANT SAFETY INFORMATION**

### **WARNING**

**A fireguard should be used for the protection of children, the elderly and infirm. Fireguards should conform to B.S. 8423 : 2002 (Fireguards for use with gas heating appliances).**

It is important that this appliance is serviced at least once a year by a GAS SAFE registered gas installer, and the thermocouple must be changed. **This is a condition of the manufacturers guarantee. After installation or during servicing a spillage test must always be carried out.**

THE FIRE MUST NOT BE OPERATED WITH THE GLASS CRACKED, BROKEN OR REMOVED. Any debris or deposits should be removed from the fuel-bed from time to time. This may be carried out by referring to the cleaning section as described later in this book.

Only the log fuel-bed must be used and only complete and genuine replacement fuel-bed logs must be sourced from BFM Europe Ltd. The appliance must only be used with the log fuel-bed supplied and must not be used with other log fuel-beds.

Always keep furniture and combustible materials well clear of the fire and never dry clothing or items either on or near to the fire. Never use aerosols or flammable cleaning products near to the fire when it is in use.

**The ceramic fuel-bed remains hot for a considerable period after use and sufficient time should be allowed for the fire to cool before cleaning etc. The fire must only be operated with the fascia supplied with the fire.**

## 5.2 LIGHTING THE APPLIANCE

- 5.2.1 The control valve is positioned centrally below the burner unit of the fire when viewed from the front.
- 5.2.2 To operate the appliance automatically via the remote control handset, ensure that the on / off switch is switched to the “on” position as shown below in Fig. 1

**Fig. 1**

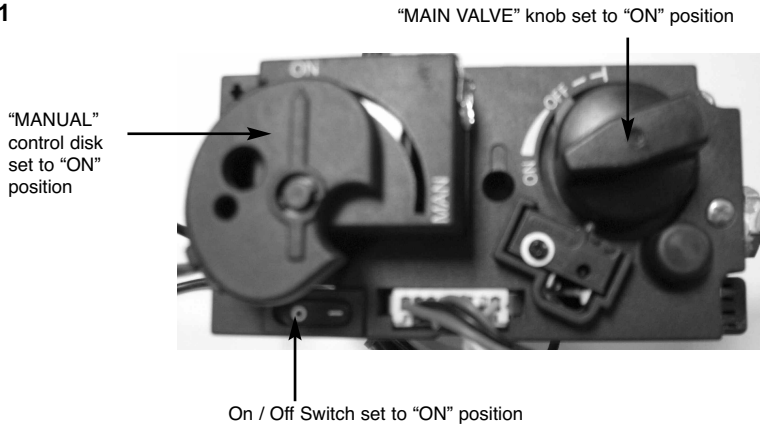

- 5.2.3 Switch the MANUAL control disc to the “on” position, (as shown above in Fig. 1)
- 5.2.4 Switch the main valve knob to the “ON” position. (as shown above in Fig. 1)
- 5.2.5 Press and hold the “STAR” button and “UP” button on the remote handset simultaneously, see Fig. 2 overpage for image of handset.
- 5.2.6 The valve will then emit an audible beep and commence its ignition sequence. When the pilot flame has been established, the control will continue to beep whilst the thermocouple heats up. When the thermocouple has reached operating temperature, it will allow gas to flow to the burner and the burner will light at high rate heat input (5.7kW).



5.2.7 The fire can now be switched between HIGH rate heat input and LOW rate heat input by pressing the “DOWN” arrow on the handset. To reduce the flame height of the main burner incrementally, press the arrow momentarily. To reduce the heat input directly down to the minimum level, press the “SMALL” flame arrow on the handset twice, NOTE : The flame will go to HIGH rate heat input before going to designated LOW rate heat input. To return back to HIGH rate heat input press the “LARGE” flame button twice. To put the fire in In “STANDBY MODE” (only the pilot remains lit) press and hold the “SMALL” flame arrow on the handset.

**AFTER THE PILOT FLAME HAS BEEN EXTINGUISHED, IF YOU WISH TO RE-LIGHT THE APPLIANCE YOU MUST WAIT AT LEAST THREE MINUTES BEFORE TRYING TO RE-LIGHT THE FIRE.**

5.2.8 Should the handset be misplaced, you can turn the fire off by switching the “ON / OFF” switch to the “OFF” position.

Fig. 2

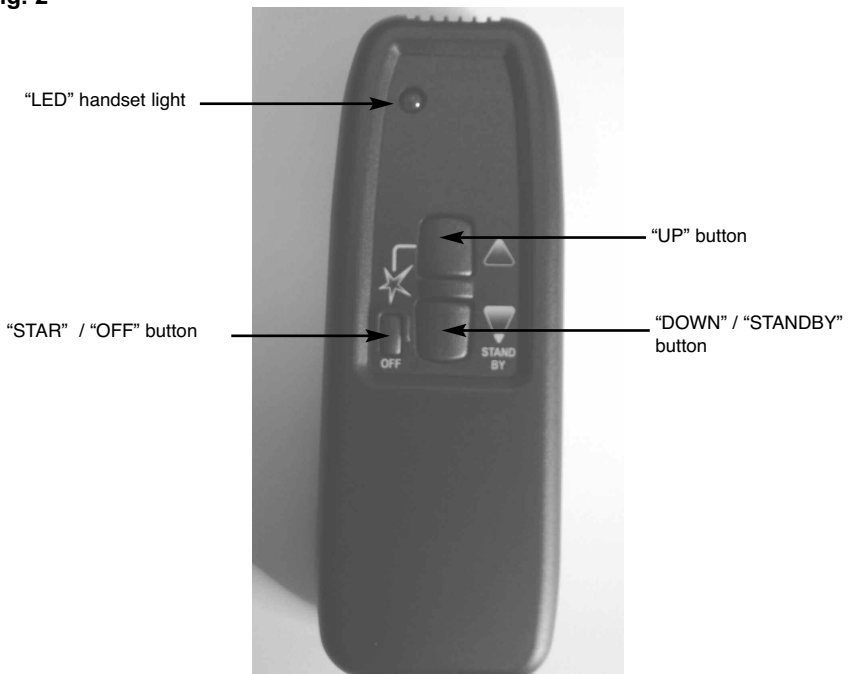

### 5.3 REMOVAL / RE-FITTING THE GLASS FRAME ASSEMBLY

5.3.1 Remove the cosmetic trim which is held in position by 2 off screws as shown below in Fig. 3

**Fig. 3**

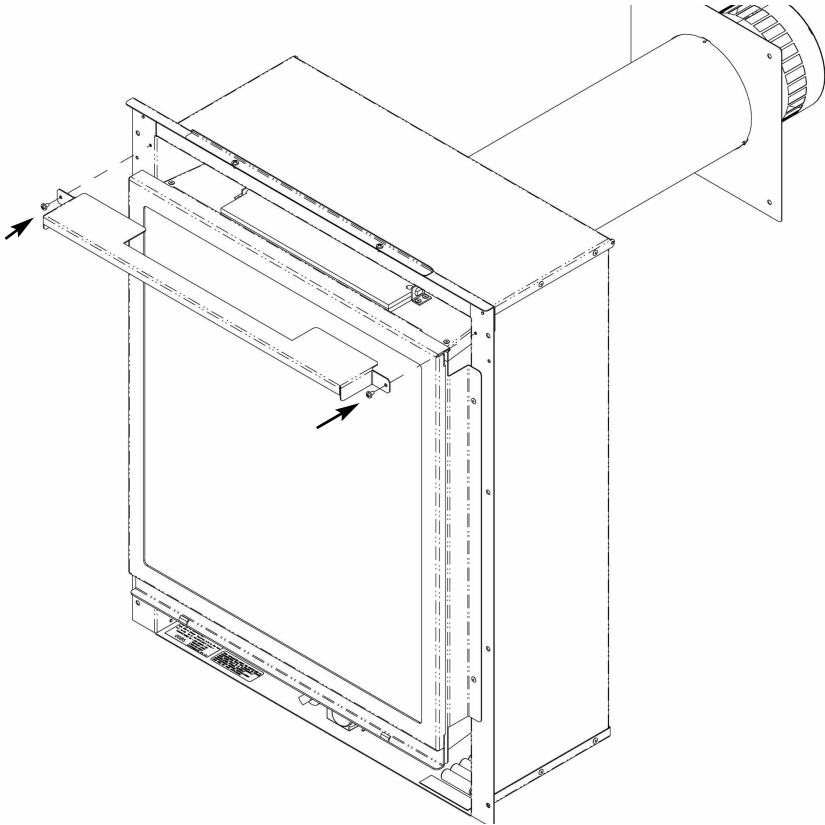

5.3.2 Release the glass panel assembly by undoing the retaining clips at the base of the glass frame as shown below in Fig. 4

**Fig. 4**

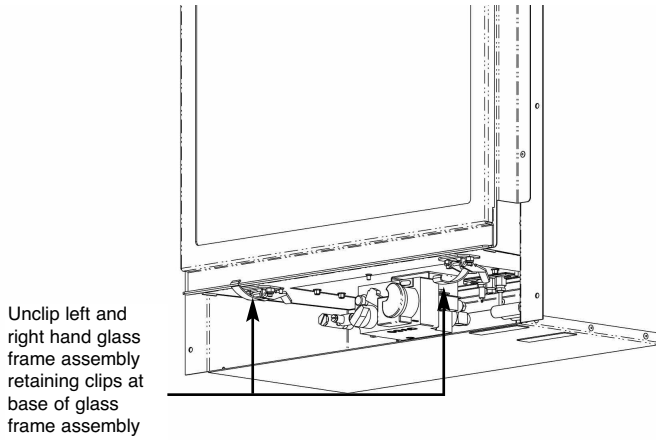

5.3.4 Remove the glass frame assembly by tilting forwards then lifting as shown in Fig. 5 below

**Fig. 5**

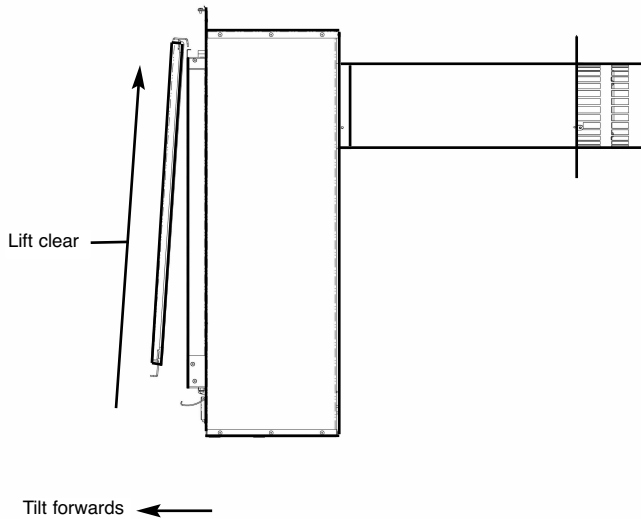

## 5.4 RE-LAYING THE FUEL-BED

- 5.4.1 Place the L/H and R/H ceramic base pieces onto the ceramic support panel as shown below in Fig. 6

**Fig. 6**



- 5.4.2 Place the front ceramic base piece onto the ceramic support ensuring the location tabs fit into the L/H & R/H ceramic base pieces as shown below in Fig. 7

**Fig. 7**



- 5.4.3 Place the base log onto the ceramic support panel as shown below in Fig. 8, ensuring the spacer locating blocks on the rear face are fitted flush up against the rear panel.

**Fig. 8**

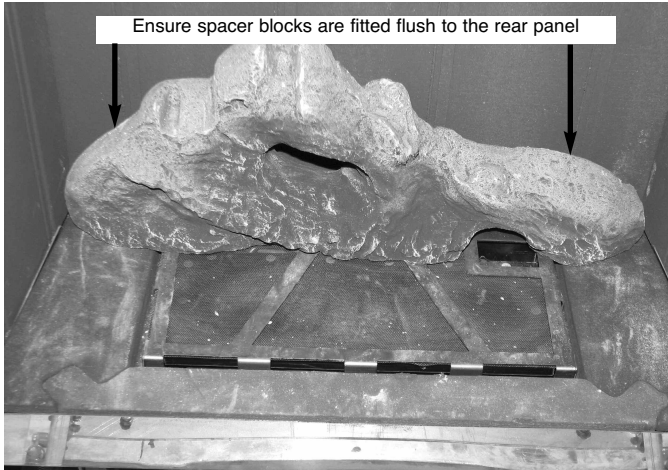

- 5.4.4 Cover the burner and fuel-bed base ceramic in a single, even layer of bark chippings as shown below in Fig. 9

**Fig. 9**



5.4.5 Position log “H” onto the base log using the location lug on the back face of log “H” and the groove on the base log to find the correct location, as shown below in Fig. 10

**Fig. 10**



5.4.6 Position log “E” onto the base log using the location lug on the back face of log “E” and the groove on the base log to find the correct location as shown below in Fig. 11

**Fig. 11**

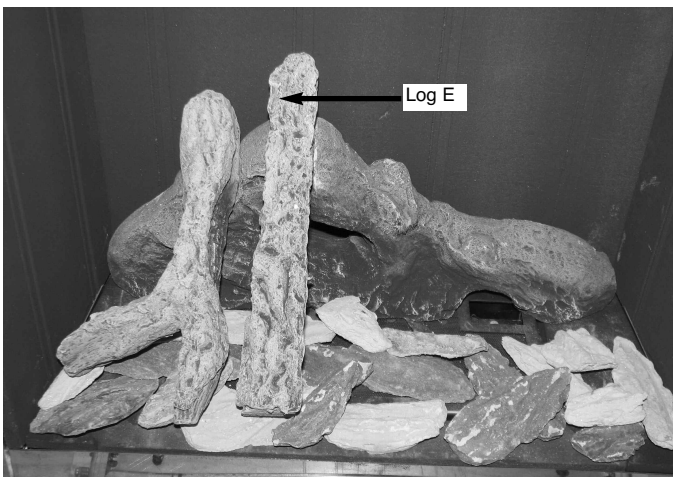

5.4.7 Position log “B” onto the base log using the location lug on the back face of log “B” and the groove on the base log to find the correct location as shown below in Fig. 12

**Fig. 12**



5.4.8 Position log “G” onto the base log using the location lug on the back face of log “G” and the groove on the base log to find the correct location as shown below in Fig. 13

**Fig. 13**



5.4.9 Re-fit the glass frame assembly as detailed in section 5.3.

**Warning : Use only the log fuel-bed supplied with the fire. When replacing the log fuel-bed remove the old log fuel-bed and discard it. Fit a complete log fuel-bed from the manufacturer, only use genuine replacements.**

#### **THE FOLLOWING STATEMENT IS APPLICABLE TO ALL FUEL-BED TYPES**

**This appliance uses fuel effect pieces containing Refractory Ceramic Fibres (R.C.F.), which are man-made vitreous silicate fibres. Excessive exposure to these materials may cause temporary irritation to eyes, skin and respiratory tract. Consequently, it makes sense to take care when handling these articles to ensure that the release of dust is kept to a minimum. To ensure that the release of fibres from these R.C.F. articles is kept to a minimum, during installation & servicing we recommend that you use a HEPA filtered vacuum to remove any dust and soot accumulated in and around the fire, before and after working on the fire. When replacing these articles we recommend that the replaced items are not broken up, but are sealed within a heavy duty polythene bag, clearly labelled as “RCF waste”. This is not classified as “hazardous waste” and may be disposed of at a tipping site licensed for the disposal of industrial waste. Protective clothing is not required when handling these articles, but we do recommend you follow the normal hygiene rules of not smoking, eating or drinking in the work area, and always wash your hands before eating or drinking.**

**This appliance does not contain any component manufactured from asbestos or asbestos related products.**

#### **5.5 CLEANING - WARNING**

Before attempting any cleaning operation ensure that the fire has been allowed to fully cool. The fascia is best cleaned in position on the fire when the appliance is not running and is cool. Black painted metal parts should be gently cleaned with a damp cloth.

To clean the glass panel, please remove it from the product as described on page 34 / 35. Use a clean damp cloth and ceramic glass cleaner to remove any stains or deposits from the glass panel. Do not use scouring pads as this may scratch the surface finish of the glass panel.

**PLEASE NOTE** :- The glass will require cleaning periodically. Condensation produced by the products of combustion will create marks on the inside face of the glass panel.



## CLEANING THE FUELBED

We do not recommend cleaning of the logs or fuelbed components as these are fragile and damage may result. **None of these parts must be washed or exposed to any cleaning agents or water.** Any damaged parts must be replaced by contacting your dealer or telephoning BFM Europe Ltd. on the number stated on the rear cover of this book. The log fuel-bed must only be replaced with a complete and genuine replacement item and the fire must never be run with a damaged item. The fuel-bed must be carefully fitted as stated in section 5.4.

### 5.6 REPLACING THE BATTERIES IN THE RECEIVER UNIT & HANDSET

- 5.6.1 4 off AA 1.5V batteries are to be fitted to the battery holder located on the base of the fire below the combustion chamber.
- 5.6.2 To remove the receiver unit, firstly remove the fascia as shown in section 5.7. Remove it from the velcro strips with which it is secured.
- 5.6.3 Slide off the cover from the receiver unit.
- 5.6.4 Fit the 4 off AA batteries to the unit, then re-fit the cover.
- 5.6.5 Replace the receiver into it's velcro strips at the base of the fire.
- 5.6.6 Fit the 1 off 9V battery to the handset by removing the rear cover, connecting the battery then replacing the cover.

## 5.7 REMOVAL / RE-FITTING THE TRIM

- 5.7.1 The trim is secured by hooking the trim over the bracket on the top flange of the firebox as shown below in Fig. 14. The bracket is adjustable to ensure the fit is correct.

**Fig. 14**

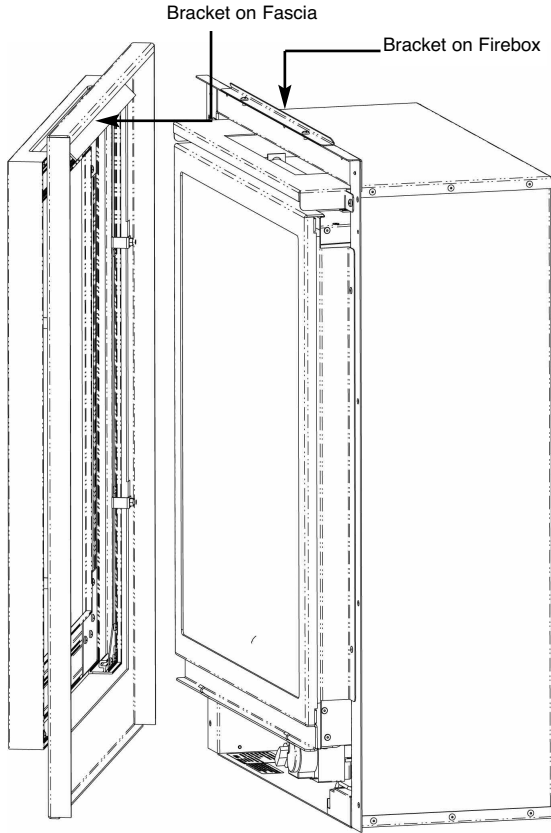

## **USER REPLACEABLE PARTS**

The only user replaceable parts on this fire are the fuelbed components and logs which may be replaced as described in the above section. Replacement of any other parts must be carried out by a competent person such as a GAS SAFE registered gas installer. The part numbers of the user replaceable parts are as follows, these are available from BFM Europe Ltd. who may be contacted at the number on the rear cover of this book.

Meridian base fibre centre section	B-137240
Meridian fibre right hand section	B-141710
Meridian fibre left hand section	B-141720
Meridian set bark chippings	B-142900
Meridian rear log	B-142130
Meridian complete log set	B-142120
Meridian log "B" only	B-134080
Meridian log "E" only	B-134110
Meridian log "G" only	B-134130
Meridian log "H" only	B-134140

Due to our policy of continual improvement and development the exact accuracy of descriptions and illustrations cannot be guaranteed.

Part No. B-144240  
Issue 4

VERINE  
FIRES ✦ TO ✦ INSPIRE

BFM Europe Ltd.  
Trentham Lakes  
Stoke-on-Trent  
Staffordshire  
ST4 4TJ

[www.bfm-europe.com](http://www.bfm-europe.com)

**Telephone - General Enquiries :**  
**Telephone - Service :**

**(01782) 339000**  
**(0844) 7700169**