

VERINE

Marcello

Balanced Flue Convector

MODEL NUMBERS: NBFPOORN, NBFPOORP

INSTALLATION, USER AND SERVICING INSTRUCTIONS

THESE INSTRUCTIONS MUST REMAIN WITH THE USER



THIS APPLIANCE MEETS THE REQUIREMENTS OF THE EUROPEAN GAS DIRECTIVE

Contents

	Page No.
List of components	3
Appliance Data	3
GENERAL INSTALLATION REQUIREMENTS	3
Fitting the Appliance	3
Placing of Decorative Refractory Shapes	9
COMMISSIONING	10
USERS GUIDE	11
Useful tips & recommendations	11
Operation of the fire	11
Opening and Closing the Fascia Panel	11
Lighting the Appliance	12
Cleaning the fire	13
SERVICING & MAINTENANCE	14
Spares Parts list	16
Installation & Service Record	17

Important Notes – Please read before undertaking the installation

1. This is not a “Do it yourself” product and it must be installed by a competent person.
2. The Installation Instructions must be adhered to without exception.
3. The heat from this appliance will cause the wall directly above the appliance to become quite hot. If there is any concern about the integrity of the plaster or wall finish, we recommend that slips made from heat resistant material are fitted to cover the wall for at least 100mm above the top of the inner fascia panel. Any remedial plasterwork above the appliance should be allowed to thoroughly dry before lighting the appliance. Premixed packet mortars should not be used as the inhibitors incorporated in these products can cause continual shrinkage after setting.

LIST OF COMPONENTS

Before commencing the installation ensure that all the components listed below are included in the appliance packaging.

- a) Balanced Flue Convector
- b) Ceramic components;
 - i) 1 packet black ceramic granules
 - ii) 1 packet of 6 'light grey stone wedge' pieces
 - iii) 1 packet of 6 'dark grey stone wedge' pieces
 - iv) 1 packet of 11 'light grey triangular stone' pieces
 - v) 1 packet of 11 'dark grey triangular stone' pieces
- c) Flue and Terminal
- d) Terminal guard
- e) Aluminium Foil Tape, flue sealing rope gasket and fittings pack
- f) Installation & Servicing and Instructions
- g) Remote Control Handset & Receiver, 4 AA & 1PP3 size alkaline batteries.
- h) 4 rolls of white foam tape

Before commencing the installation ensure that all the components listed below are included in the fascia packaging.

- a) Fascia Panel
- b) Decorative trim and 4 magnets (if ordered)

Inset Installations only

- a) Wall plate (must be used for Inset Installations)

APPLIANCE DATA:

	NBFPOORN	NBFPOORP
GAS TYPE	NATURAL GAS	PROPANE
SUPPLY PRESSURE	20mb	37mb
HEAT INPUT	4.5 kW Gross	4.25kW Gross
GAS RATE	0.43m ³ /h	0.16 m ³ /h 305g/hr
INJECTOR SIZE	Ø 1.6 mm	Ø1.05 mm
GAS CONNECTION	8mm COMPRESSION	
WEIGHT	40 Kgs	
NOx Concentration	Class 5	

GENERAL INSTALLATION REQUIREMENTS

Fitting the Appliance

- 1 The law demands that all gas appliances are installed by a qualified installer in accordance with the current **GAS SAFETY (INSTALLATION AND USE) REGULATIONS**. The installation must comply with these installation instructions and all relevant parts of Local and National Building Standards (Scotland) (Consolidation) Regulations and those relevant recommendations of the following British Standards.

BS 5871: Part 1 BS 8303 BS 5440: Parts 1 & 2 BS 6891 BSEN1856 Parts 1 & 2 BS 5482 Part 1, as well as IGE/UP/7.

2 The appliance can be fitted onto and inset into outside walls where the terminal does fall into any of the prohibited positions mentioned in the next section. The centre of the glass window is 157mm below the centre of the flue terminal. The centre of the terminal should be positioned at least 700mm above floor level to allow space for the fascia to drop down on its runners. If the fireplace has to be altered a lintel will be required to support masonry over the opening and if it is to be surface mounted the maximum wall thickness allowed is 405mm. If the appliance is to be inset into the wall this may be increased to 525mm.

If required, a longer flue duct is available which allows the maximum wall thicknesses to be increased to 800mm for the surface mount installation and 920mm for the inset installation.

3 **Flue Terminal Position**

The minimum distances permissible from the flue terminal to obstructions and ventilation openings are shown below.

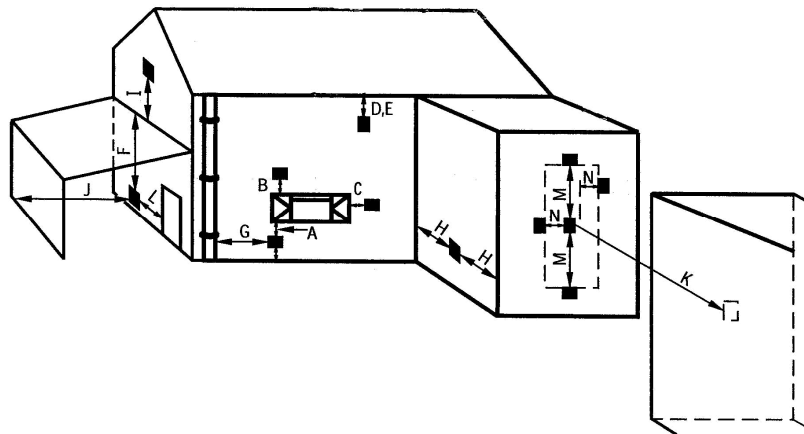

Figure 1

DIMENSION	TERMINAL POSITION	MINIMUM DISTANCE
A	Directly below an opening, air brick or window, etc.	300mm
B	Above an opening, air brick, opening windows, etc.	300mm
C	Horizontally to an opening, air brick, opening windows, etc.	300mm
D	Below plastic gutters, soil pipes or drain pipes	300mm
E	Below eaves	300mm
F	Below balconies or car port roof.	600mm
G	From a vertical drainpipe or soil pipe. (Eire only 75)	(GB) 300mm
H	From an internal or external corner.	600mm
I	Above ground, roof or balcony level.	300mm
J	From a surface facing the terminal.	600mm
K	From a terminal facing a terminal.	600mm
L	From an opening in a carport (e.g. door, window) into the dwelling.	1200mm
M	Vertically from a terminal on the same wall.	1500mm
N	Horizontally from a terminal on the same wall.	300mm
Not shown	From an opening in a building directly opposite.	600mm

4 **Decorative Fascia Panel**

This appliance must be installed with the fascia panel set supplied. This panel allow the passage of air for convection and for the cooling of the control system. It must be installed as described in these instructions. The fire should never be left running with this fascia panel dropped down. This will overheat both the fascia and glass window.

5 **Ventilation**

This is a room-sealed appliance; therefore, there is no requirement for purpose made ventilation into the room containing the fire.

6 The appliance is designed for use with both natural gas and propane. The two gases require different burners that are not interchangeable between the different gas types.

7 The appliance must not be installed in a room containing a bath or shower or in a private garage.

8 **Shelf**

If a shelf made of combustible material is to be fixed to the wall above the appliance a space of at least 150mm must be left between the top of the fascia and the underside of the shelf.

9 **THE HEARTH** (Appliances in floor level fireplaces)

Where the appliance is fitted in a floor level builders opening, floor level fireplace recess or floor level flue box, the hearth shall:

- a, Extend through the whole base of the builders opening, fireplace recess or beneath the flue box.
- b, Project at least 275mm in front of the glass window panel.
- c, Project at least 150mm beyond each side of the edge of the glass window panel. or if there is a non-combustible wall within 150mm of glass panel, up to that wall.
- d, Have a thickness of not less than 12mm and a minimum height of 50mm along its front and side edges.

Hole-in-the-wall installations

Where the appliance is installed in a hole-in-the-wall fireplace, a hearth as previously detailed for floor level fireplaces shall be fitted on the floor beneath the hole so as to protect combustible material from radiant heat.

- a, If a hearth is not to be used, so as to maintain a minimal and contemporary styling, the appliance must be installed so that the base of the appliance is at least 200mm vertically above any carpet or floor covering.
- b, Where no hearth is to be fitted **consideration** should be given to fixing a tactile separator to protect young children, the elderly and the infirm. A tactile separator can be in the form of a fender, kerb, hearth, shelf or horizontal bar all made from non combustible material and fixed not less than 50mm & not more than 1000mm above the floor level. It should be

positioned not less than 275mm in front of and 150mm beyond the edge of the window glass.

10 Combustible Walls & Timber Framed Dwellings

The appliance may be fitted directly to wall made both from combustible and non combustible material. If it is to inset into the wall, the inner wall plate (supplied separately) must be used and a gap of 25mm should be maintained between the top, rear and sides of the convector box and any combustible material. These gaps should be filled with mineral wool insulation.

A gap of 50mm must be maintained between the outer flue and any combustible material including the external wall. This gap must be filled with mineral wool insulation.

Installations into timber framed dwellings must follow the recommendations of IGEM/UP/7 'Gas Installation in Timber Framed Buildings' available from The Institute of Gas Engineers and Managers'. The appliance must not be inset unless provision has been made by the builders with the approval of the designers of the dwelling.

Fitting

This appliance can be installed either by being fixed directly on to the surface or it can be inset into the inner leaf of a cavity wall. Before starting the installation remove the glass door by unscrewing the eight nuts securing the door and place in a safe place until required.

Undoing the nuts and bolts on the outer flanges of the appliance separate the heat exchanger from the convector box.

Surface Installation

- 1 Select a position for the appliance and mark the centre of the flue. This should be at least 700mm above finished floor level. (This is to give sufficient clearance to allow the door to drop down). The centre of the glass panel will be 157mm below this mark (See Figure 2). At this position drill a 152mm diameter hole in the wall for the flue. Apply white foam tape (supplied) around the edges of the back of the convector box to form a dust seal between the box and the wall.

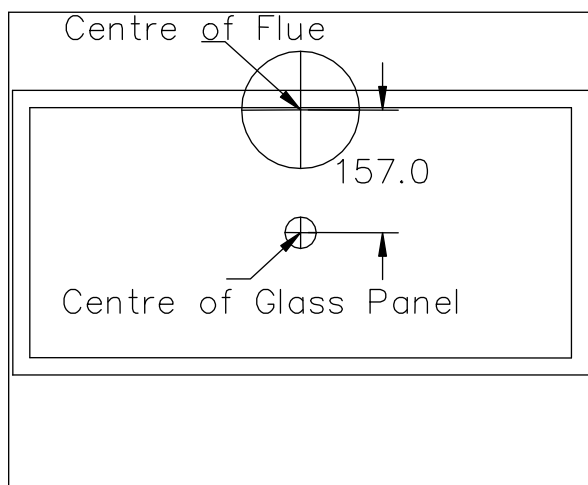

Figure 2

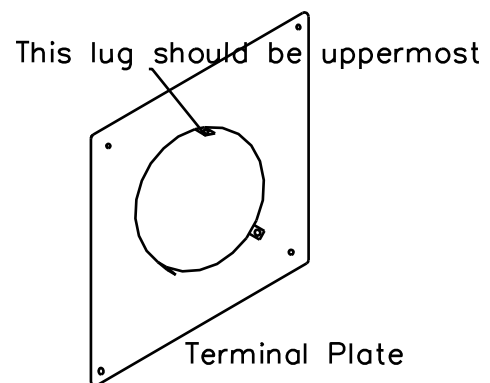

Figure 3

- 2 Thread the outside Terminal plate onto the flue and push the flue into the wall from the outside. Apply mastic to the rear face of the Terminal plate and fix to the wall using screws and wall plugs. Make sure the plate is fixed the correct way up. (See Figure 3) Slide the flue further into the wall until the tabs on the wall plate line up with the holes in the outer flue tube. Temporarily fix the tube to the wall plate with the self tapping screws provided. Use the inner holes as shown in Figure 4.

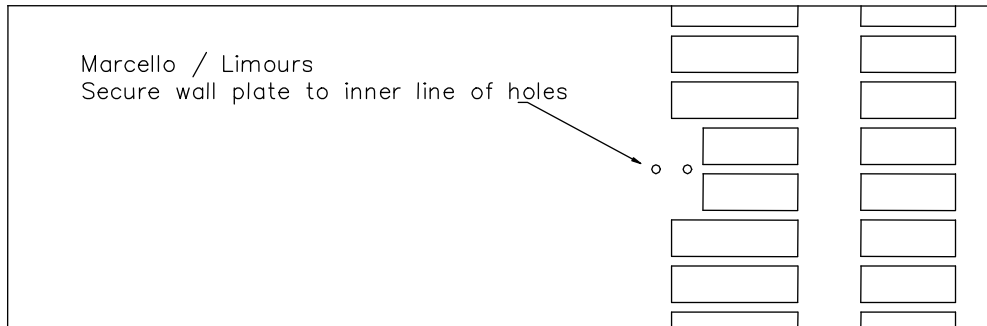

Figure 4

- 3 On the inside wall centre and level the convector box over the protruding flue pipe. Once level, fix the convector box to the wall with four screws and wall plugs. The convector box has been designed to ensure an air gap remains between the wall and the back of the convector box. Consideration should be given to ensure this gap is achieved and not affected by uneven wall surfaces.
- 4 From the inside of the convector box measure inwards along the flue 6mm. At this point draw a line completely around the outer pipe. Unscrew the self tapping screws securing the outer flue tube to the wall plate and withdraw the flue assembly. Move the polystyrene support ring inside the flue assembly to a position near the marked line. Cut the excess flue of at the marked line. De-bur the cut edges and remove the polystyrene ring.
- 5 Slide the remaining piece of flue, which should include the terminal, on to the flue connection on the back of the heat exchanger. Note that the two flue tubes are not concentric and that the inner tube is positioned towards the top of the outer tube. Using a 3.5mm diameter drill, drill holes through the holes in the flue outer ring and into the outer flue tube. Secure in place with self tapping screws and then cover and seal the joint with the length of aluminium tape supplied. Thread the fibreglass rope ring sealing gasket on to the flue.
- 6 The gas supply should be routed from the meter or cylinder to a point underneath or behind the appliance. There are two grommated apertures provided for gas pipe entry in the convector box. From this point route the supply in 8mm diameter tubing to the combined pressure test point and isolator fitting. Any exposed pipe within the wall cavity should be wrapped, painted with bituminous paint or factory sheathed. Prior to connecting the burner to the gas supply it is advisable to blow out the pipe to clear any dirt that may be present and which could cause a blockage in the control valve or pilot.
- 7 Lift the heat exchanger and flue assembly and slide the flue assembly through the hole in the wall until the heat exchanger flange meets the convector box flange. Fix the heat exchanger to the convector box using the M5 nuts and bolts supplied. Replace the self tapping screws that secured the flue to the wall plate. Seal the flue to the wall plate with mastic. Fit the terminal guard centrally over

the terminal using screws and wall plugs.

- 8 If plasterwork requires to be made good, please pay attention to note no. 3 on page 2 of these instructions

Inset Installation

- 1 To inset the Marcello gas fire, a wall plate, supplied separately, must be used.
- 2 Select a position for the appliance and the height required from the centre of the glass panel to the floor. Cut a hole in the inner leaf of the cavity wall to the dimensions shown in Figure 5. A lintel may be required to support the masonry over the opening .Any cavity wall insulation should be held back away from the appliance. Drill a 152mm diameter hole in the outer leaf of the cavity wall for the flue 157mm above the position of the centre of the glass panel. Ensure that the centre of the flue is at least 700mm above finished floor level.

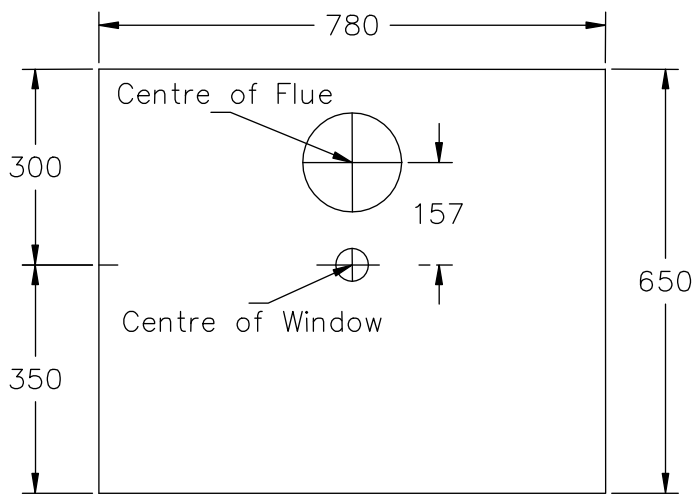

Figure 5

- 3 Thread the outside wall plate onto the flue and push the flue into the wall from the outside. Apply mastic to the rear face of the wall plate and fix to the wall using screws and wall plugs. Make sure the plate is fixed the correct way up. (See Figure 3) Slide the flue further into the wall until the tabs on the wall plate line up with the holes in the outer flue tube. Temporarily fix the tube to the wall plate with the self tapping screws provided. Use the inner holes as shown in Figure 4.
- 4 Temporarily screw the convector box to the inner wall plate with four M5 screws. Place the convector box over the protruding flue pipe and push the box into the hole already cut in the inner leaf of the cavity wall. Centre the convector box over the flue pipe. Once level, fix the inner wall plate to the wall with six screws and wall plugs. Cover the access holes to these screws with the six black plastic plugs supplied. Once the convector box has been finally secured to the inner fascia the arrangement can be considered to have sealed the cavity. Any gaps around the inner fascia and any other gaps can be sealed with mastic.
- 5 From the inside of the convector box measure along the flue 6mm. At this point draw a line completely around the outer pipe. Unscrew the self tapping screws securing the outer flue tube to the wall plate and withdraw the flue assembly. Move the polystyrene support ring inside the flue assembly to a position near the marked line. Cut the excess flue of at the marked line. De-bur the cut edges and remove the polystyrene ring.
- 6 Slide the remaining piece of flue, which should include the terminal, on to the

flue connection on the back of the heat exchanger. Note that the two flue tubes are not concentric and that the inner tube is positioned towards the top of the outer tube. Using a 3.5mm diameter drill, drill holes through the holes in the flue outer ring and into the outer flue tube. Secure in place with self tapping screws and then cover and seal the joint with the length of aluminium tape supplied. Thread the fibreglass rope ring sealing gasket on to the flue.

- 7 The gas supply should be routed from the meter or cylinder to a point underneath or behind the appliance. There are two grommets apertures provided for gas pipe entry in the convector box. From this point route the supply in 8mm diameter tubing to the combined pressure test point and isolator fitting. Any exposed pipe within the wall cavity should be wrapped, painted with bituminous paint or factory sheathed. Prior to connecting the burner to the gas supply it is advisable to blow out the pipe to clear any dirt that may be present and which could cause a blockage in the control valve or pilot.
- 8 Remove the four M5 screws holding the convector box to the inner fascia. Lift the heat exchanger and flue assembly and slide the flue assembly through the hole in the wall until the heat exchanger flange meets the convector box flange. Fix the heat exchanger through the convector box flanges to the inner fascia using the M5 bolts supplied. Replace the self tapping screws that secure the flue to the wall plate. Seal the flue to the wall plate with mastic. Fit the terminal guard centrally over the terminal using screws and wall plugs.
- 9 If plasterwork requires to be made good, please see note no. 3 on page 2.

Placing of Decorative Refractory Shapes

- 1 Pour enough black ceramic granules to fill the space between the front air guide and the window opening. The granules should finish level with the top of the window ledge.
- 2 Four packets of "stone" pieces are supplied with the fire (in two shades of grey). Open the 2 packets containing 6 off wedge shaped pieces.
- 3 Place ten of these wedge pieces behind the rear air guide with the longer wedge pointing downwards. These pieces should be supported by the rear air guide and by the board at the rear of the fire. See Figure 6.

Figure 6

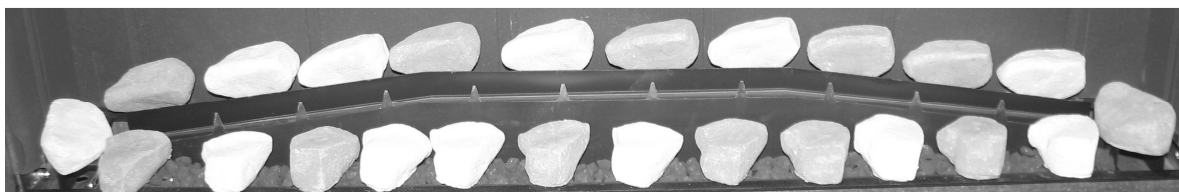

- 4 Place the two remaining wedge pieces on top of the brackets at either end of the air guides (alternate colours as necessary throughout placing these 12 off).
- 5 Two pieces from the second packet should be placed at each end of the air guides. They should rest partly on the front air guide and partly on the black ceramic granules. See Figure 6.

Figure 7



- 6 Place twelve 'triangular stone' pieces on top of the black ceramic granules in front of the front air guide as shown in Figure 6.
- 7 Place the remaining ten 'triangular Stone' pieces from the second packet across the air guides pushing each piece down on a location spike formed in the front air guide. See Figure 7.
- 8 It is important that the ceramic pieces are placed as per these instructions.

Closing the Glass Door

- 1 Place the glass door in position over the studs on the heat exchanger making sure the joint in the rope seal lies along the lower edge. Secure in position with the eight nuts. Tighten evenly.

Installing the Fascia Panel

- 1 Check that the fascia panel is mounted the correct way up. A TEE is punched in the top of the inner flanges.
- 2 Ensure the four M4 screws are mounted in their bushes on the inner flanges.
- 3 Offer the fascia up to the appliance and slide the heads of the M4 screws through the cut – outs and into the slots formed in the sides of the convector box.
- 4 Make sure that the fascia panel slides up and down freely and locks in the top position.

COMMISSIONING:

- 1 Before attempting to light the appliance the gas supply must be turned on by removing the cap from the isolator fitting and unscrewing the plug all the way out. Replace the cap making sure that the tab engages with the slot in the top of the plug. Tighten the cap securely. Check all joints with leak detection fluid. Light the appliance in accordance with the instructions in the lighting section.
- 2
 - a. Locate the gas control battery pack – signal receiver from the packaging. Plug the white multi point connector on to the edge strip protruding from the side of the box. Connect the terminals on the other end of the wire to the connectors next to the drive motor on the body of the gas control.
 - b. Slide back the battery compartment cover and insert the four AA size alkaline batteries observing the correct polarities. Replace the cover and place the battery box on the floor of the convector box.
 - c. Fit the battery into the handset by removing the access cover in the rear of the handset and inserting a 9 volt PP3 size battery. Connect the battery by pushing the connector on to the terminals. Make sure the battery is connected correctly. Replace the access cover.

Briefing the User

- 1 Demonstrate the full operation of the appliance to the customer.
- 2 Inform the customer that all cleaning procedures should be carried out only when the appliance is cold.
- 3 Leave these instructions with the customer.
- 4 Advise the importance of having the appliance serviced on an annual basis.

USERS GUIDE:

Useful tips & recommendations

Once your fire has been fitted, the following recommendations are made to ensure you enjoy the best results from your purchase;

- 1 The installation of this appliance must have been carried out by a qualified installer and in accordance with the requirements of the **Gas Safety (Installation & Use) Regulations**
- 2 The glass door and the upper part of the fascia panel are considered to be working surfaces and as such will become hot when in use. Care should be exercised when using the controls of the appliance when it is hot. We also recommend that a fireguard, conforming to BS 6539 or BS 6778, be fitted for the protection of young children, the elderly or infirm.
- 3 When new, any painted surfaces or ceramic components may produce a slight odour, but this will completely vanish after a few hours of use.
- 5 The appliance **MUST NOT** be used with the front fascia panel in the dropped down position or with the glass panel removed. If there is any suspicion of damage to the glass the appliance must not be used.
- 6 To obtain the best results from your fire we recommend that it be serviced annually.
- 7 These instructions are provided to assist you to operate the fire correctly and should be kept in a safe place.
- 8 If you have any reason to suspect a gas leak, turn off the appliance at the isolating point and contact your installer.
- 9 Curtains should not be hung above the appliance.

Operation of the fire

- 1 The pilot flame heats the thermocouple probe and allows gas to flow to the burners. If due to pilot failure, the thermocouple cools, no gas will flow to the main burner. If the fire is turned off or the flames go out, wait for **AT LEAST 3 MINUTES** before attempting to relight the fire.
- 2 For convenience you will find with the appliance a card giving concise lighting instructions, please keep this in a safe place.

Opening and Closing the Fascia Panel

CAUTION: ONLY DO THIS WHEN THE FIRE IS COLD

- 1 To open the fascia panel grip it at each side, lift slightly, pull outwards and lower.
- 2 This will allow access to the gas control and to the battery pack-signal receiver to light the appliance and change the batteries.
- 3 To close the fascia grip it at each side, lift fully, push forwards and release. Always grip the fascia at each side where it will be cool and not at the top where it may be very hot.

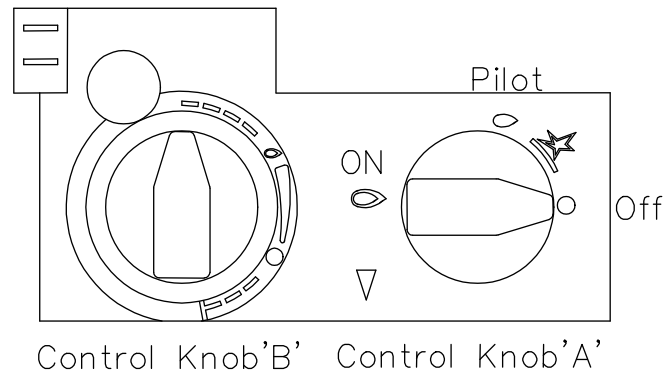

Figure 8

Lighting the Appliance

- 1 **Lighting:** See Figure 8.
 - a Push in and turn control knob 'A' anti-clockwise to the PILOT position.
 - b Hold knob 'A' in for several seconds to purge any air from the system.
 - c With knob 'A' still depressed turn it from the "OFF" position to the "PILOT" position until the pilot light ignites. Continue to depress the control knob for a further 10-15 seconds. Release the control knob, the pilot should stay alight. If the pilot flame goes out, repeat the process, holding down the control knob for a slightly longer period.
 - d Depress control knob 'A' slightly and turn anti-clockwise to the ON position. The main burner will not operate until this is done. The main burner may light depending on the position of Control Knob 'B'.
 - e **Manual override for remote control**
Turn Control Knob 'B' anti-clockwise to increase the flame height and clockwise to decrease the flame height.

2 **Extinguishing**

- a **Manual override for remote control**
Turn Control Knob 'B' fully clockwise. This will turn off the main burner leaving the pilot burner alight.
- b Turn Control Knob 'B' to the pilot position. This will also turn off the main burner leaving the pilot burner alight.
- c To extinguish the pilot burner, turn Control Knob 'B' to the off position.

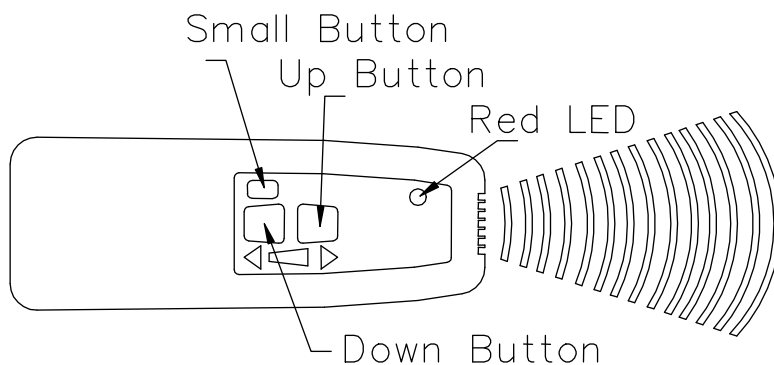

Figure 9

Adjusting the Flame Height using the Remote Control Handset (Figure 9)

The remote control system fitted to the fire uses ultrasound to transmit signals between the handset and the fire. It will work best if the grill at the front of the handset is pointed in the direction of the fire. To prevent inadvertent ignition of the fire the UP button on the handset will not function unless the SMALL button is held down at the same time. A loud clicking noise indicates that control knob 'B' has reached the end of its travel.

- a **Make sure that the pilot burner has been lit and Control Knob 'A' has been turned to the ON position. Also ensure that batteries have been fitted to the handset and to the battery pack-signal receiver.**
- b To light the main burner or increase the flame height press and hold the UP button and the SMALL button on the handset. Release when the flame is at the desired height. The electric motor should be heard moving Control Knob 'B'.
- c To extinguish the main burner or reduce the flame height press and hold the DOWN button on the handset. Release when the flame is at the desired height or has gone out. Once again the electric motor should be heard moving Control Knob 'B'.

Cleaning the fire

Ensure that the appliance is cool. Regular dusting with a dry cloth is usually all that is necessary to keep your appliance looking at its best. From time to time it may be necessary to clean the steel surface with a slightly damp cloth - do this while the fire is cool and ensure that no water remains on the appliance surface.

Glass

Let the fire and glass cool completely. Only the outside of the glass can be cleaned by the user. Wash the glass with warm water, using a soft paper towel or cloth, rinse and dry thoroughly. Never use abrasive or harsh chemicals to clean the glass.

For stubborn deposits use a cleaner available from your dealer. Do not allow the cleaner to touch any brass or stainless steel ornamentation. Ensure that the fire is cold before undertaking any cleaning. Remember that heat is retained for some time after the fire is switched off. In normal use your fire requires only minimal cleaning. Some soot may form on any ceramic pieces placed in the flames but this is generally harmless unless an excessive amount is deposited.

SERVICE AND MAINTENANCE

BEFORE ANY SERVICING IS CARRIED OUT ISOLATE THE APPLIANCE FROM THE GAS SUPPLY. AFTER REFITTING THE APPLIANCE, CHECK FOR GAS SOUNDNESS AT ALL GAS JOINTS AND TEST FOR SPILLAGE.

This product uses fuel effect pieces containing Refractory Ceramic Fibre (RCF). This material contains man-made vitreous silicate fibres. Excessive exposure to these materials may cause temporary irritation to eyes, skin and respiratory tract; consequently, it makes sense to take care when handling these articles to ensure that the release of dust is kept to a minimum.

To ensure that the release of fibres from these RCF articles is kept to a minimum, during installation and servicing we recommend that a HEPA filtered vacuum cleaner is used to remove any dust accumulated in and around the appliance before and after working on the appliance. We recommend that any replaced items are not broken up, but are sealed within heavy duty polythene bags and clearly labelled as RCF waste. RCF waste is classed as a stable, non-reactive hazardous waste and may be disposed of at landfill sites licensed to accept such waste. Protective clothing is not required when handling these articles but we recommend that the normal hygiene rules are followed of not smoking, eating or drinking in the work area and that hands are washed before eating or drinking.

The appliance should be serviced at least once a year by a CORGI registered engineer. This is the basic procedure.

- 1 Remove the fascia panel. See section above headed 'Installing the Fascia Panel'.
- 2 Unscrew the eight nuts and remove the glass door.
- 3 The stone wedges and triangular pieces should be taken off the fire. The centre row should be carefully lifted off the locating spikes and kept in order so that they can be returned to their original positions. All the pieces should be shaken to remove any debris but should only be cleaned if absolutely necessary. This should be done by gently brushing with a soft brush in a direction away from the person and any persons nearby. This operation should be performed outside facing downwind.
- 4 Remove all the black ceramic granules.
- 5 Undo the two screws holding the air guide assembly in position a lift it gently out of the firebox making sure the black ceramic granules remain in their locating tray. Remove the two screws holding the burner and lift it out of the appliance.
- 6 Thoroughly clean the burner ports.
- 7 The injector can be inspected without removing the control mount platform by unscrewing it with a small box spanner or pliers.
- 8 To remove the control mount platform;
 - a Disconnect the isolator fitting from the gas control.
 - b Remove the 2 screws holding the left hand board bracket. Remove the bracket and left hand lining board.

- c Remove the screw holding the pilot draught shield to the pilot bracket and lift the shield away.
 - d Remove the six screws securing the control mount platform to the firebox. Take care not to damage the gasket.
- 9 Replace the control mount platform (if it has been removed) and secure with the six screws previously removed. Replace the pilot shield and the lining board and bracket. Re-connect the gas supply. Place the burner and air guide assembly in position ensuring that the mixing tube locates in its hole in the burner mount over the injector and fix in place with the four screws removed in paragraph 5. Replace the refractory shapes that were in place on the burner.
- 10 Replace the black ceramic granules in the tray attached to the air guide. Replace the stone wedges and triangular pieces should be replaced exactly as they were removed making sure that the centre row are replaced on the spikes using the original piecing in the stones.
- 11 After cleaning the glass door inside and out replace it and secure with the eight nuts. Tighten the nuts evenly. Stubborn marks can be removed with steel wool and detergent.

AFTER REFITTING THE APPLIANCE CHECK FOR GAS SOUNDNESS AT ALL GAS JOINTS.

- 12 Replace the fascia panel.
- 13 The service record sheet enclosed with these instructions should be complete to maintain the validity of the warranty.

Battery Replacement

- 14 **HANDSET;** The handset is powered by one Alkaline 9volt PP3 size battery. If the fire fails to respond to the handset control check that the red LED on the handset lights whilst pressing either of the two buttons. If the LED does not light, the battery in the handset requires renewing. To change the battery in the handset, remove the battery cover on the underside of the handset, unclip the battery from its connector and put a new one put in its place. Replace the cover.
- 15 **BURNER;** Open the fascia panel. Lift out the gas control battery pack – signal receiver from its position on the bottom tray of the convector box. Slide back the battery compartment cover and replace the four AA size alkaline batteries observing the correct polarities. Replace the cover and then replace the battery box in its clip.

Spare Parts List

In the event of a part requiring replacement the parts list is as follows

Part Description	Part Number
Motorised valve	CV-104103
Remote hand control & Receiver	CV-104413
Pilot Burner NG Model	CV-104506
Pilot Burner LPG Model	CV-104513
Injector NG Model	CV-104608
Injector LPG Model	CV-104601

Installation & Service Record

Please ensure that installer completes the installation record below

<u>INSTALLATION RECORD</u>
Appliance Supplied by:
Installation Date:Serial No.:
Installed By:CORGI No.:
Signed by Installer:

<p><u>RECORD OF 1st SERVICE</u></p> <p>Serviced by: CORGI No.:.....</p> <p>Service Date: Signed:</p> <p>Comments:</p> <p>.....</p> <p>.....</p>	<p><u>RECORD OF 2nd SERVICE</u></p> <p>Serviced by: CORGI No.:.....</p> <p>Service Date: Signed:</p> <p>Comments:</p> <p>.....</p> <p>.....</p>
<p><u>RECORD OF 3rd SERVICE</u></p> <p>Serviced by: CORGI No.:.....</p> <p>Service Date: Signed:</p> <p>Comments:</p> <p>.....</p> <p>.....</p>	<p><u>RECORD OF 4th SERVICE</u></p> <p>Serviced by: CORGI No.:.....</p> <p>Service Date: Signed:</p> <p>Comments:</p> <p>.....</p> <p>.....</p>
<p><u>RECORD OF 5th SERVICE</u></p> <p>Serviced by: CORGI No.:.....</p> <p>Service Date: Signed:</p> <p>Comments:</p> <p>.....</p> <p>.....</p>	<p><u>RECORD OF 6th SERVICE</u></p> <p>Serviced by: CORGI No.:.....</p> <p>Service Date: Signed:</p> <p>Comments:</p> <p>.....</p> <p>.....</p>
<p><u>RECORD OF 7th SERVICE</u></p> <p>Serviced by: CORGI No.:.....</p> <p>Service Date: Signed:</p> <p>Comments:</p> <p>.....</p> <p>.....</p>	<p><u>RECORD OF 8th SERVICE</u></p> <p>Serviced by: CORGI No.:.....</p> <p>Service Date: Signed:</p> <p>Comments:</p> <p>.....</p> <p>.....</p>
<p><u>RECORD OF 9th SERVICE</u></p> <p>Serviced by: CORGI No.:.....</p> <p>Service Date: Signed:</p> <p>Comments:</p> <p>.....</p> <p>.....</p>	<p><u>RECORD OF 10th SERVICE</u></p> <p>Serviced by: CORGI No.:.....</p> <p>Service Date: Signed:</p> <p>Comments:</p> <p>.....</p> <p>.....</p>

B-111770
Issue 3

BFM Europe Limited
Trentham Lakes
Stoke on Trent, Staffordshire ST4 4TJ
Tel: (01782) 339000 Fax: (01782) 339009
Email: info@bfm-europe.com
www.bfm-europe.com