

VERINE

FIRES ✦ TO ✦ INSPIRE

Alpena

COAL EFFECT BALANCED FLUE GAS FIRE

Installation, Maintenance & User Instructions

Hand these instructions to the user

Model No. NBFC**MN2, NBFC**RN2 & NBFC**EN2 are for use on Natural Gas (G20) at a supply pressure of 20 mbar in G.B. / I.E.

Model No. NBFC**MP2 is for use on Propane Gas (G31) at a supply pressure of 37 mbar in G.B. / I.E.

** denotes trim / fret or fascia variant

CONTENTS

		PAGE
Section 1	Information and Requirements	
1.0	Appliance Information	3
1.1	Conditions of Installation	4
1.2	Fireplace surround & suitability	4
1.3	Flue Terminal Position	5
1.4	Shelf position	6
1.5	Hearths	6
Section 2	Installation of Fire	
2.1	Unpacking the fire	6
2.2	Fireplace opening	7-8
2.3	Preparation of the wall	8-9
2.4	Preparation of the flue hole	9
2.5	Installation of the gas supply	10
2.6	Preparation of the flue duct	11
2.7	Securing the firebox to the opening	12-13
2.8	Making the gas connection	13
2.9	Fitting the terminal guard	14
2.10	Removal & refitting of the glass frame	15
Section 3	Assembling Fuel Bed and Commissioning	
3.1	Fitting the fuel bed	16-18
3.2	Fitting the trim	18
3.3	Fitting the fret	18
3.4	Lighting the appliance (MC variants)	19
3.5	Fixing the infrared sensor in position (RC variants)	20
3.6	Connecting the battery pack (RC variants)	21
3.7	Lighting the appliance (RC variants)	22
3.8	Lighting the appliance (EFC variants)	23
Section 4	Maintenance	
4.1	Removal of the burner assembly (all variants)	24
4.2	Removal of the piezo Igniter (MC variants)	24
4.3	Removal of the control valve (MC variants)	25
4.4	Removal of the pilot assembly (all variants)	25
4.5	Removal of the control board (RC & EFC variants)	26
4.6	Removal of the control valve (RC & EFC variants)	26
4.7	Removal of the IR sensor (RC variants)	26
4.8	Removal of the battery holder / lead (RC & EFC variants)	26
4.9	Removal of the EFC trim switch	27
4.10	Parts shortlist	27
Section 5	User Instructions	
5.1	Installation Information / about your fire	28-29
5.2	Operating your fire (MC variants)	30
5.3	Operating your fire (RC variants)	31
5.4	Operating your fire (EFC variants)	32
5.5	Turning off the RC / EFC model if the handset is lost or broken	33
5.6	Changing the batteries (RC / EFC variants)	33
5.7	Removal / replacing the glass frame	34
5.8	Removal / replacing the fuel-bed	35-37
5.9	User replaceable parts	38

SECTION 1 INFORMATION AND REQUIREMENTS

1.0 APPLIANCE INFORMATION

	Natural Gas	LPG
Main injector : (1 off)	1.65mm	1.20mm
Pilot Type - S.I.T.140 Series	Size 27	Size 19
Max. Gross Heat Input :	4.6kW	4.8kW
Min. Gross Heat Input :	3.2kW	3.4kW
Gas Rate :	0.427 m ³ /hr	0.180 m ³ /hr
Cold Pressure :	20.0+/-1.0 mbar	37.0+/-1.0 mbar
Ignition :	Push-button Piezo (MC models only)	
Ignition :	Electronic (RC & EFC models only)	
Electrode Spark Gap :	4.0mm	
 Weight (without fender) :	 25.0 kg inclusive of flue pipe and terminal	

Fig 1

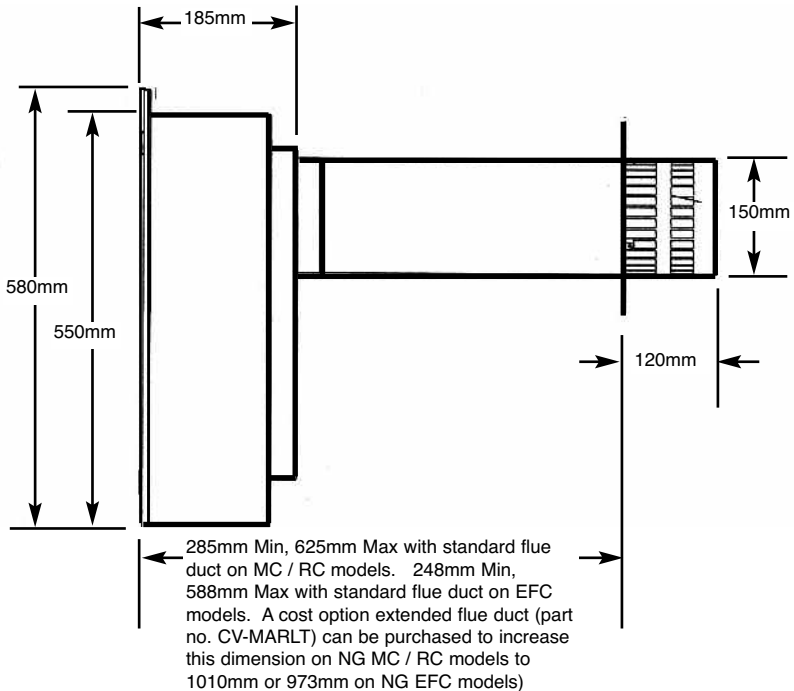

INSTALLATION REQUIREMENTS

Efficiency Declaration

The efficiency of this appliance has been measured as specified in BS EN 613 : 2001 and the result is 85%. The gross calorific value of the fuel has been used for this efficiency calculation.

The test data from which it has been calculated has been certified by BSI Testing Services.

The efficiency value may be used in the UK Government's Standard Assessment Procedure (SAP) for energy rating of dwellings.

1.1 CONDITIONS OF INSTALLATION

It is the law that all gas appliances are installed only by a GAS SAFE Registered Installer, in accordance with these installation instructions and the Gas Safety (Installation and Use) Regulations 1998 as amended. Failure to install appliances correctly could lead to prosecution. It is in your own interest and that of safety to comply with the law.

The installation must also be in accordance with all relevant parts of the Local and National Building Regulations where appropriate, the Building Regulations (Scotland Consolidation) issued by the Scottish Development Department, and all applicable requirements of the following British Standard Code of Practice.

1. B.S. 5871 Part 1 Installation of Gas Fires
2. B.S. 6891 Installation of Gas Pipework
3. B.S. 5440 Parts 1 & 2 Installation of Flues and Ventilation
4. I.S 813 : 1996 Domestic Gas Installation, issued by the National Standards Authority of Ireland.

1.2 FIREPLACE / SURROUND SUITABILITY

This product is designed to fit fireplaces with a minimum 1" / 25mm rebate. The fire must only be installed on a hearth it **must not be installed directly onto carpet or other combustible floor materials**. The fire is suitable for fitting to non-combustible fire place surrounds and proprietary fire place surrounds with a temperature rating of at least 150 degrees celcius (Class "O").

Soft wall coverings such as blown vinyl, wall paper etc. could be affected by the rising hot air and scorching and/or discoloration may result. Due consideration should be made to this when installing or decorating.

1.3 FLUE TERMINAL POSITION

The minimum acceptable dimensions from the flue terminal to obstructions and ventilation openings are shown below and listed in the table. It is important that the position of the flue allows the free passage of air across it at all times. The minimum acceptable space from the flue terminal to obstructions and ventilation openings are specified below (Fig. 2)

Fig. 2

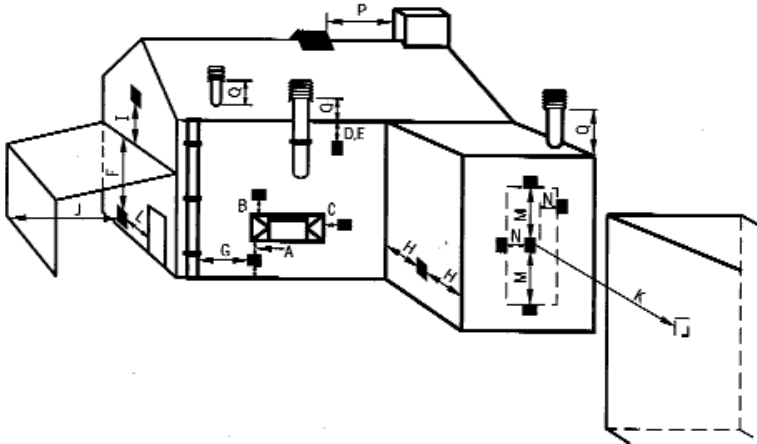

DIMENSION	TERMINAL POSITION	MINIMUM DIMENSION
A	Directly below an opening, air brick, opening window	300mm (12in)
B	Above an opening, air brick, opening window	300mm (12in)
C	Horizontally to an opening, air brick, opening window etc.	
D	Below gutters, soil pipes or drain pipes	300mm (12in)
E	Below eaves	300mm (12in)
F	Below balconies or car port roof	600mm (12in)
G	From a vertical drain pipe or soil pipe	300mm (12in)
H	From an internal or external corner	600mm (24in)
I	Above ground roof or balcony level	300mm (12in)
J	From a surface facing the terminal	600mm (24in)
K	From a terminal facing the terminal	600mm (24in)
L	From an opening in the car port	1200m (48in)
M	Vertically from a terminal on the same wall	1500mm(59in)
N	Horizontally from a terminal on the same Wall	300mm (12in)
O	NOT APPLICABLE	N/A
P	NOT APPLICABLE	N/A
Q	NOT APPLICABLE	N/A

1.4 SHELF POSITION

The fire may be fitted below a combustible shelf providing there is a minimum distance of 200mm above the top of the fire and the shelf does not project more than 150mm. If the shelf overhangs more than 150mm the distance between the fire and the shelf must be increased by 15mm for every 25mm of additional overhang over 150mm.

1.5 HEARTHES

This appliance must only be installed on to a concrete or non-combustible hearth. The hearth material must be a minimum thickness of 12mm with the top surface at least 50mm above the floor. The hearth must be fitted symmetrically about the fire opening and have a minimum width of 760mm and a minimum projection of 300mm forwards from the fire opening.

SECTION 2 INSTALLATION OF FIRE

2.1 UNPACKING THE FIRE

Carefully lift the fire out of the carton. Remove the loose item packaging carefully from the the pack. Check the contents as listed :-

IMPORTANT : THE CARDBOARD FITMENT THAT IS AT THE TOP OF THE CONVECTION APERTURE SHOULD NOT BE REMOVED UNTIL THE APPLIANCE IS FULLY INSTALLED AND READY TO BE LIT.

DO NOT UNDER ANY CIRCUMSTANCES USE THIS APPLIANCE IF THE GLASS PANEL IS BROKEN OR NOT SECURELY FIXED TO THE FIREBOX.

Packing Check List

- 1 off Fire box & foam seal / burner assembly
- 1 off Boxed ceramic 5 piece fuel bed set
- 1 off Flue terminal / pipe unit
- 1 off Flue terminal guard
- 1 off Loose Items pack including cable fixing kit
- 1 off Installation / user manual (combined)
- 6 off AA batteries (RC / EFC models only)
- 1 off PP3 battery (RC models only)
- 1 off Rubber grommet (to seal gas aperture used)

2.2 FIRE PLACE OPENING

- 2.2.1 The front opening of the fire place must be between 410 and 420mm wide, and between 555 and 570mm high. If the opening exceeds these dimensions then a surround must be constructed from suitable non-combustible material to produce a suitable sized opening. Any surround must be suitably sealed to the fire place to prevent leakage. See fig. 3 below

Fig. 3

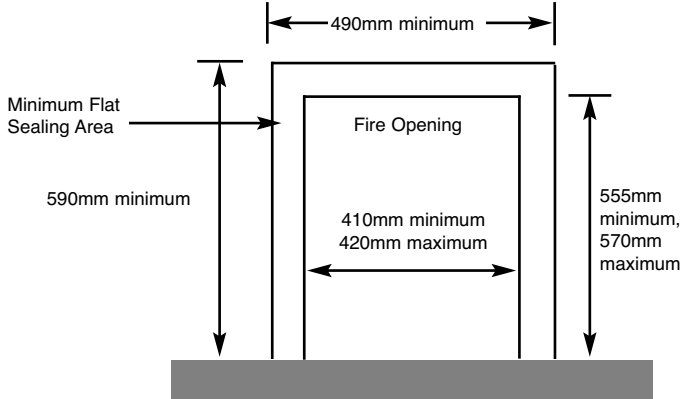

- 2.2.2 The minimum / maximum sized distances between the firebox mounting flange and outside wall are shown below in Fig. 4

Fig. 4

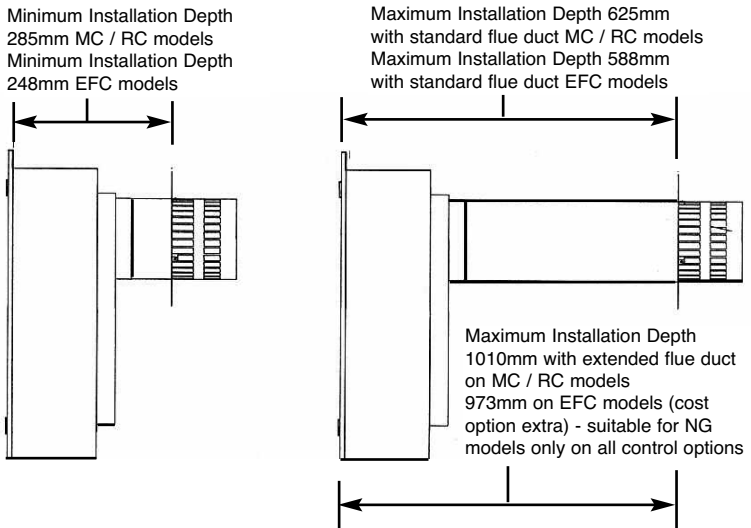

- 2.2.3 **NOTE : WHEN MEASURING LENGTH BETWEEN FIREBOX AND THE OUTER WALL TAKE INTO ACCOUNT THE DISTANCE BETWEEN THE BACK OF THE FIREBOX AND THE INNER WALL AS THIS WILL VARY BETWEEN INSTALLATIONS, DEPENDENT UPON THE FIRE SURROUND REBATE OR CAVITY DEPTH. (DIMENSION "X" BELOW - FIG. 5).**

Fig. 5

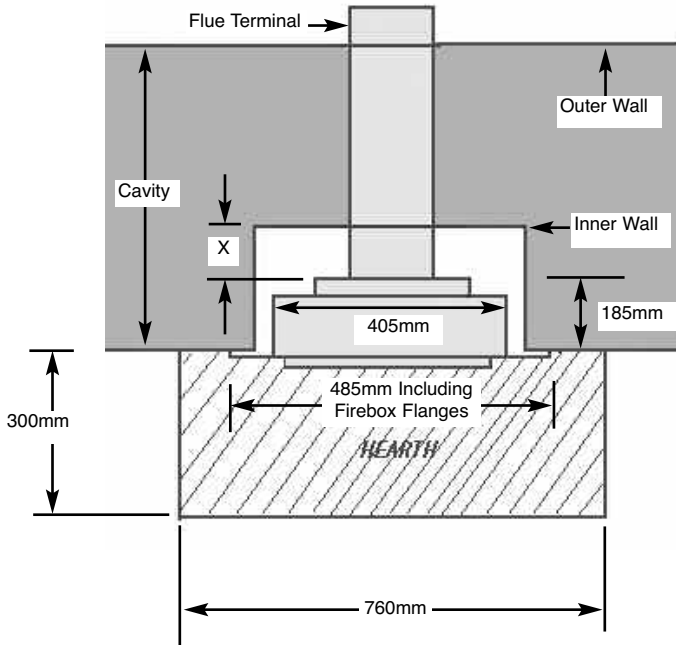

- 2.2.4 The appliance must be fitted into a fireplace or false chimney constructed of non-combustible materials, minimum width 410mm, minimum height 555mm and minimum surround or false chimney breast rebate 75mm.

2.3 PREPARATION OF THE WALL

- 2.3.1 The appliance and flue pipes must be installed at right angles to the mounting wall. The appliance itself should be installed vertically against a flat wall. Where an uneven wall surface is found, appropriate action should be taken to ensure that the appliance is not stressed or does not distort when installed.
- Ensure that the floor surface onto which the appliance is mounted onto is flat. The minimum height from the floor to the centre of the flue is shown on fig. 6 overpage.

Fig. 6

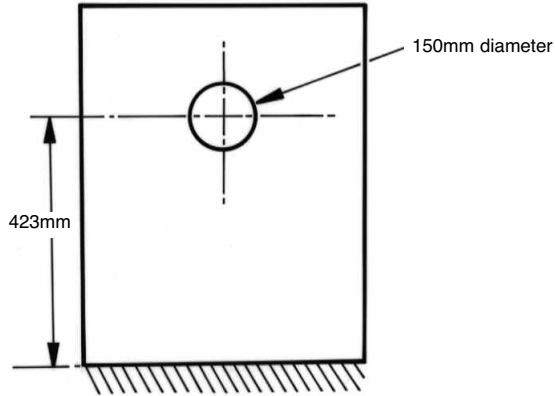

2.4 PREPARATION OF THE FLUE HOLE

2.4.1 Mark the position of the centre of the flue on the inner wall.

2.4.2 Cut hole for outer flue pipe. There are two possible methods to achieve this, either core drill or via hammer and chisel.

2.4.3 To core drill, proceed as follows :-

Drill a pilot hole through the wall, in position as specified in figure 6.

Using a 6" core drill, drill the flue hole.

To Hammer and chisel, proceed as follows :-

Mark the position of the centre of the flue pipe as specified in figure 6.

Mark the position of the hole around this point.

Chisel out the area as marked on the wall.

2.4.4 We then recommend that a cardboard cylinder is placed around the flue pipe and inserted in the chiselled out hole whilst making good.

NOTE :- If the appliance is to be installed into a building under construction, it is recommended that a non-corrosive metal tube of 6" diameter be inserted into the position of the hole.

2.5 INSTALLATION OF THE GAS SUPPLY

2.5.1 Before installing the firebox, decide from which side or if a rear connection to the gas supply is required. Plan the pipe run to enter the firebox from the left, right or rear and connect to the inlet elbow. See below :-

2.5.2 If concealed pipe work is required plan the pipe run to enter the fire box through one of the openings in the sides or rear of the fire box and connect to the inlet elbow. See Fig. 7 & 8 below for a suggested concealed pipe layout.

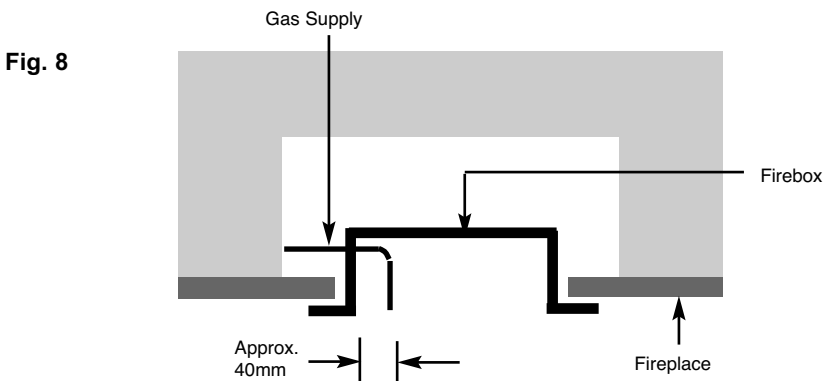
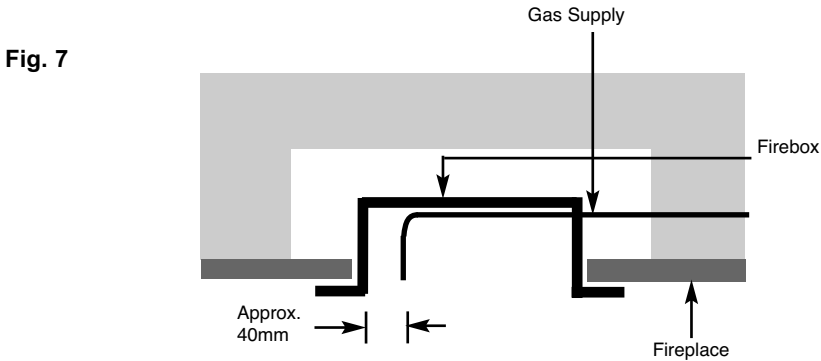

Note : Before breaking into the gas supply a pressure drop test should be carried out to establish that the existing pipework is sound. Always insert the grommet into the entry point used (a sharp blow with a hammer or chisel will be sufficient to knock out the opening selected in the firebox) and with the grommet fitted cut with a sharp knife to allow the supply pipework to pass through into the firebox.

2.6 PREPARATION OF THE FLUE DUCT

- 2.6.1 Place the firebox into the fire opening with fire surround correctly secured in the final position. From the outside of the house measure from the face of the outside wall to the rear panel of the firebox through the flue hole. Cut the flue duct to this size, using the polythene support ring to support the flue whilst being cut. Remove the polystyrene support ring from the flue duct and remove burrs from the pipe.

IMPORTANT : ENSURE THE PIPES ARE CUT SQUARELY.

- 2.6.2 The joint between the firebox and the flue duct as shown below in Fig. 9 must be secured with screws and sealed with the foil tape as supplied. In order to do this, the wall plate must be removed from the flue pipe / termination.

Fig. 9

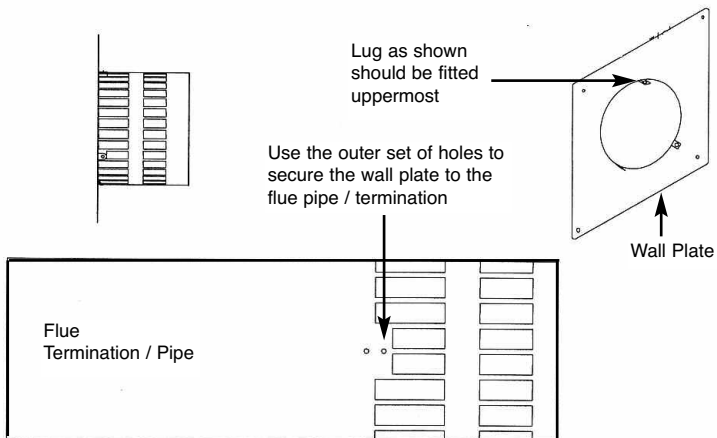

- 2.6.3 Due to the varying lengths of flue that will be required via differing installations it will be necessary to drill the flue pipe using the 3 off holes in the mounting flange on the rear of the combustion chamber as a guide for positioning. When the holes have been drilled and the screws fitted, wrap the joint with the foil tape supplied.
- 2.6.4 Re-fit the wall plate ensuring the outer set of holes as indicated above in Fig. 9 are used. Use a high temperature sealant to secure the wall plate to the outside wall of the property before securing with the screws and rawplugs supplied to ensure a mechanical fix.

2.7 SECURING OF FIREBOX TO THE OPENING

2.7.1 There is a choice of methods of fixing the firebox that are provided to enable the installer to deal with any type of installation. The preferred method of fixing the appliance is the cable fixing method, which is described in detail in the following section.

2.7.2 If the standard firebox fixing flange is to be used, the firebox may be secured using the cable method, but in installations where the cable method is not suitable, e.g. insufficient space behind the firebox, or loose masonry, the firebox can be fitted directly to either the front of the fireplace via the flange with the four off screws provided. The firebox will require sealing to the fireplace, regardless of the method used.

2.7.3 To secure the fire using the preferred cable method, proceed as follows below :-

2.7.4 Mark out and drill 4 off No 14 6mm holes in the rear face of the fire opening in the positions as shown in Fig. 10 below.

Fig. 10

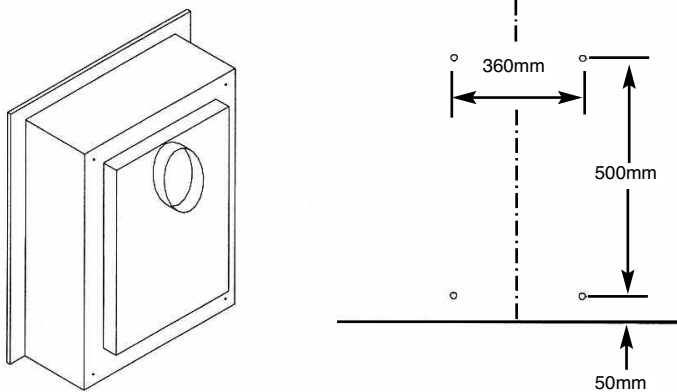

2.7.5 Fit the wall plugs provided and screw the fixing eyes securely into the rear of the fire opening.

2.7.6 Uncoil the two fire fixing cables and thread one end of each of the cables through the rear of the fire box, and through each fixing eye at the top. Thread both cables through the fixing eye's at the bottom, then the holes at the bottom of the firebox

2.7.7 Thread the cables through the rear of the firebox, insert the flue pipe / terminal through the hole in the rear of the opening and offer the firebox up to the fireplace.

- 2.7.8 To improve access to tension the screws it may be advantageous to remove the control panel from the fire. To do this, remove the 4 off retaining screws and on MC models, remove the control valve retaining nut.
- 2.7.9 Thread a tensioning screw over both of the cables and ensure that the tensioning nut is screwed fully up against the hexagon shoulder of the tensioning screw (this provides maximum travel for the tensioning nut).
- 2.7.10 Fit a screwed nipple on to each of the cables and pull hand tight up against the tensioning screw, then secure each nipple with a flat bladed screwdriver.
- 2.7.11 Before making the final gas connection, thoroughly purge the gas supply pipework to remove all foreign matter, otherwise serious damage may be caused to the gas control valve on the fire.
Failure to purge the gas supply will invalidate the guarantee.

2.8 MAKING THE GAS CONNECTION / PRESSURE TESTING

- 2.8.1 The gas connection should be made to the appliance inlet elbow to using 8mm rigid tubing.
- 2.8.2 Remove the pressure test point screw from the inlet elbow and fit a manometer.
- 2.8.3 Turn on the main gas supply and carry out a gas tightness test.
- 2.8.4 Depress the control knob and turn anti-clockwise to the position marked pilot. Hold in the control knob for a few seconds to purge the pipe work then press the igniter button. The burner should light, continue to hold the control knob for a few seconds then turn to the full-on position. If lighting an RC or EFC variant , please consult section 3.5 to 3.8.
- 2.8.5 Check that the gas pressure is **20.0 mbar (+/- 1.0mbar) 8.0 in w.g.(+/- 0.4 in w.g.) for NG models and 37.0 mbar (+/- 1.0mbar) 14.8 in w.g.(+/- 0.4 in w.g.) for LPG models**
- 2.8.6 Turn off the fire, remove the manometer and refit the pressure test point screw. Check the pressure test point screw for gas tightness with the appliance turned on using a suitable leak detection fluid or detector.

2.9 FITTING THE TERMINAL GUARD

- 2.9.1 With the flue terminal in position, place the terminal guard over the top of the flue terminal and mark the position of the holes on the outer wall.
- 2.9.2 Remove the terminal guard and drill the 4 off 6 mm holes.
- 2.9.3 Insert the raw plugs into the drilled holes, replace the terminal guard over the top of the flue terminal and attach to the wall using the No.12 x 40mm screws provided with the terminal guard.

NOTE : In England & Wales, building regulations require that a terminal guard should be fitted if the terminal could come into contact with people near the building or be subject to damage. BFM Europe Ltd. also recommend the fitting of a flue terminal guard where regulations do not demand that it be fitted. A suitable flue terminal guard is supplied with the appliance.

2.10 REMOVING & REFITTING OF THE GLASS FRAME.

- 2.10.1 Remove the 2 screws which hold the convection slot cover to the firebox, as shown below in Fig 11
- 2.10.2 Remove the burner heat shield by unscrewing the 2 off retaining screws as shown below in Fig. 11
- 2.10.3 Remove the 4 off M5 retaining nuts as shown below in Fig. 11
- 2.10.4 Remove the 3 off top retaining screws as shown below in Fig. 11
- 2.10.5 Remove the 2 off bottom retaining screws as shown below in Fig. 11
- 2.10.6 Re-assemble in reverse order.

NOTE : Always ensure that a consistent seal between the combustion chamber and the glass frame is achieved.

Fig. 11

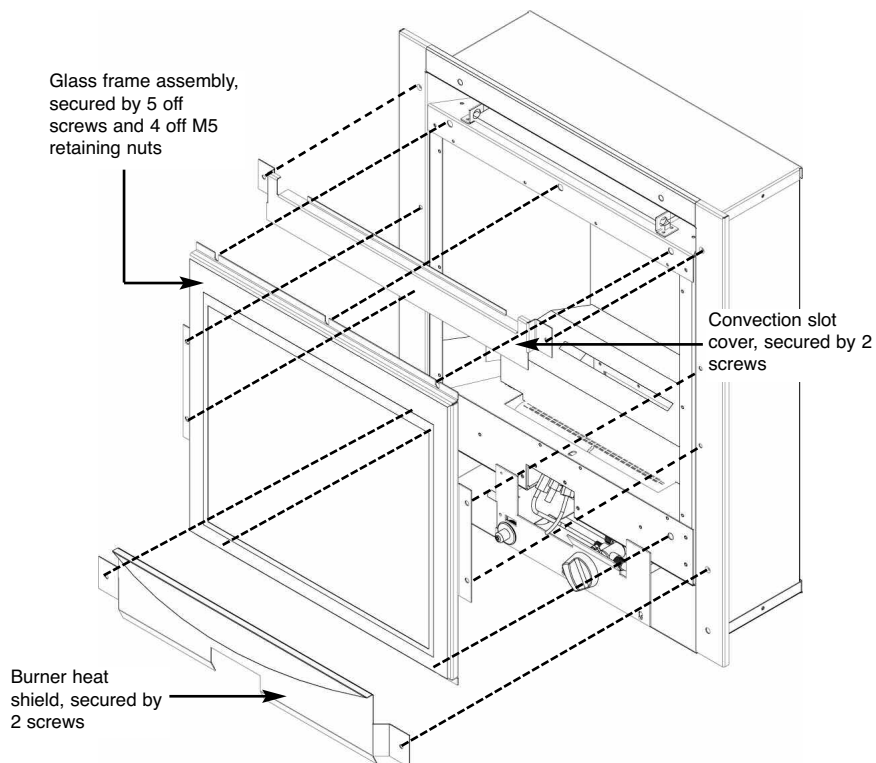

SECTION 3 ASSEMBLING FUEL BED AND COMMISSIONING

3.1 FITTING THE FUELBED

- 3.1.1 Place the ceramic fibre support behind the burner as shown below in Fig. 12

Fig. 12

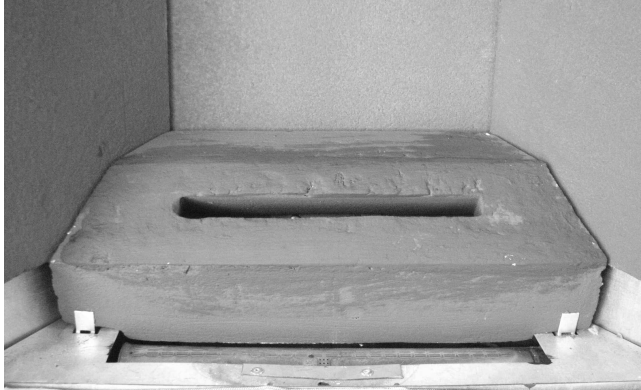

- 3.1.2 Place the front right coal moulding onto the front coal support as shown below in Fig. 13

Fig. 13

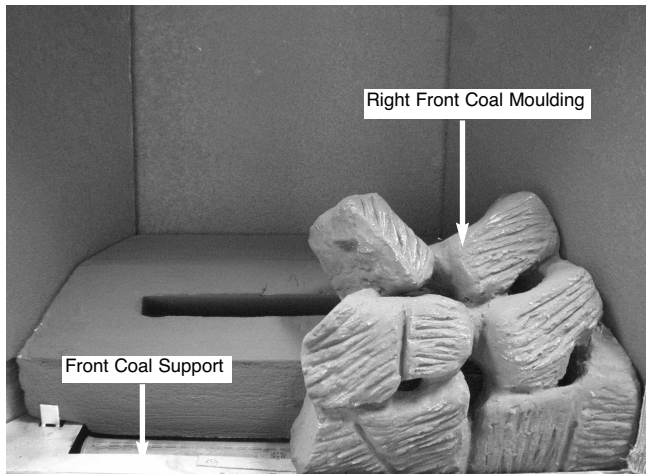

3.1.3 Place the front left coal moulding onto the front coal support as shown below in Fig. 14

Fig. 14

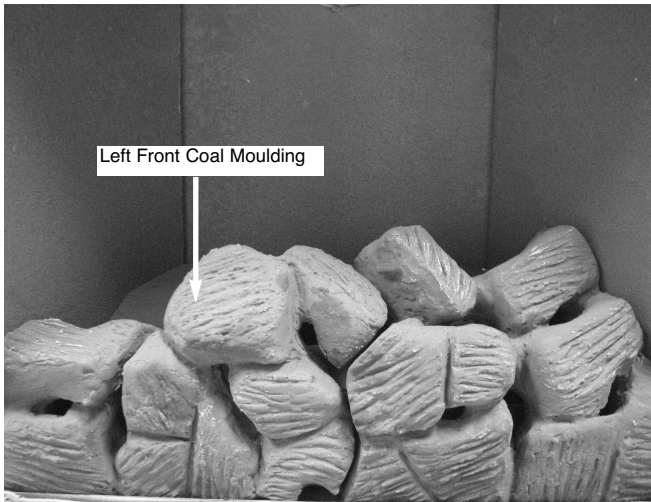

3.1.4 Place the upper right coal moulding as shown below in Fig. 15. This moulding tucks under the front right coal moulding and is supported by the ceramic fibre support.

Fig. 15

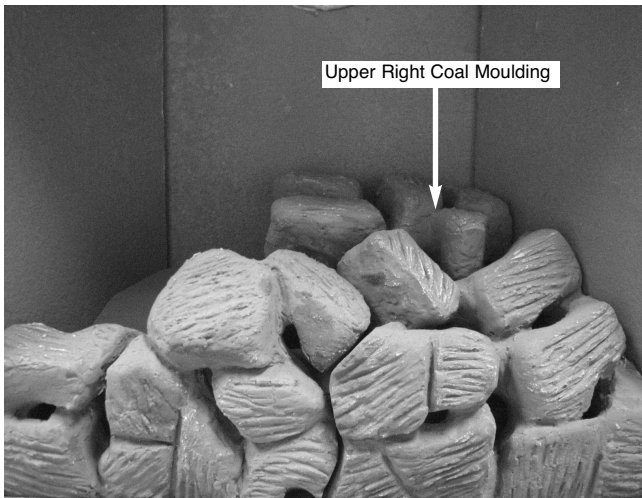

- 3.1.5 Place the upper left coal moulding as shown below in Fig. 16. This moulding tucks under the front left coal moulding and is supported by the ceramic fibre support.

Fig. 16

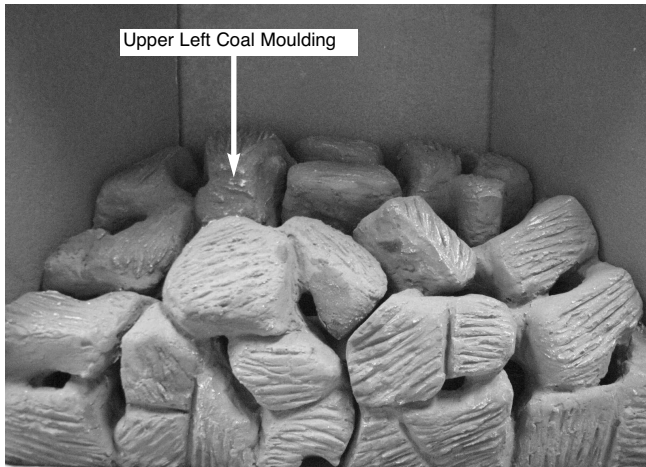

- 3.1.5 Refit the glass frame as detailed in section 2.10, then light the appliance as detailed in section 3.2 / 3.3

To ensure that the release of fibres from these R.C.F (Refractory Ceramic Fibre) articles is kept to a minimum, during installation and servicing we recommend that you use a HEPA filtered vacuum to remove any dust accumulated in and around the appliance before and after working on the appliance. When replacing these articles we recommend that the replaced items are not broken up, but are sealed within heavy duty polythene bags, clearly labelled as “RCF waste”. RCF waste is classed as a “stable”, non reactive hazardous waste and may be disposed of at a landfill licensed to accept such waste Protective clothing is not required when handling these articles, but we recommend you follow the normal hygiene rules of not smoking, eating or drinking in the work area, and always wash your hands before eating or drinking.

3.2 FITTING THE TRIM (ALL MODELS)

- 3.2.1 The trim is held in position on the fixing flange by magnets.

3.3 FITTING THE FENDER (ALL MODELS)

- 3.3.1 The fender is placed up to the front of the ceramic front rail on all models. Position the ashpan under the fender and centralise.

3.4 LIGHTING THE APPLIANCE - MANUAL CONTROL VARIANTS

IMPORTANT NOTE : IF THE BURNER IS EXTINGUISHED FOR ANY REASON YOU MUST ENSURE THAT YOU WAIT A FULL FIVE MINUTES BEFORE ATTEMPTING TO RE-LIGHT THE FIRE.

WHEN TURNING THE FIRE “OFF” PLEASE ENSURE THAT THE CONTROL VALVE IS TURNED TO THE “OFF” POSITION AND THE PILOT FLAME IS EXTINGUISHED. DO NOT LEAVE THE PILOT FLAME ONLY LIT.

- 3.4.1 Turn on the gas restrictor at the inlet fitting.
- 3.4.2 Depress the control knob and turn anti-clockwise to the position marked pilot. Hold in the control knob for a few seconds to purge the pipe work.
- 3.4.3 Continue to hold-in the control knob and press the igniter button. If the burner does not light, continue to press the igniter button until ignition occurs. Continue to hold the control knob for 5-10 seconds to allow thermocouple to heat up, if the pilot goes out when the control knob is released, repeat the lighting sequence.
- 3.4.4 Turn the control knob in the anti-clockwise direction to the high position and the main burner will light.
- 3.4.5 Turn the control knob clockwise to the low position and the gas input will be reduced to the minimum setting.
- 3.4.6 Slightly depress the control knob and turn to the pilot position, the main burner will go out but the pilot will remain lit.
- 3.4.7 Slightly depress the control knob and turn to the off position, the pilot will now be extinguished.
- 3.4.8 After ensuring that the fire is safe to use it should be left on high position to fully warm up. During this time a slight odour may be noticed, this is due to the “newness” of the fire and will soon disappear.

Finally, hand the Installation and Maintenance Instructions and the Users Instructions over to the customer and explain the operation of the fire.

NOTE : THIS APPLIANCE IS DESIGNED TO WORK SAFELY AND EFFECTIVELY DURING ADVERSE WEATHER CONDITIONS. HOWEVER, DURING SUCH TIMES FLAME DISTURBANCE MAY BE NOTICED. THIS IS NORMAL AND DOES NOT EFFECT OR IMPAIR THE SAFETY OF THE APPLIANCE.

3.5 FIXING THE INFRARED SENSOR IN POSITION - REMOTE CONTROL MODELS ONLY

3.5.1 Due to the different fascia's that can be supplied with these fires, the infrared sensor is supplied from the factory attached to a self adhesive pad. This pad can therefore be attached to the hearth in a position to suit the form of the fret assembly that is chosen with the product. Fig. 17 below shows the self adhesive pad and infrared eye attached to the flying lead, as supplied from the factory.

Fig. 17

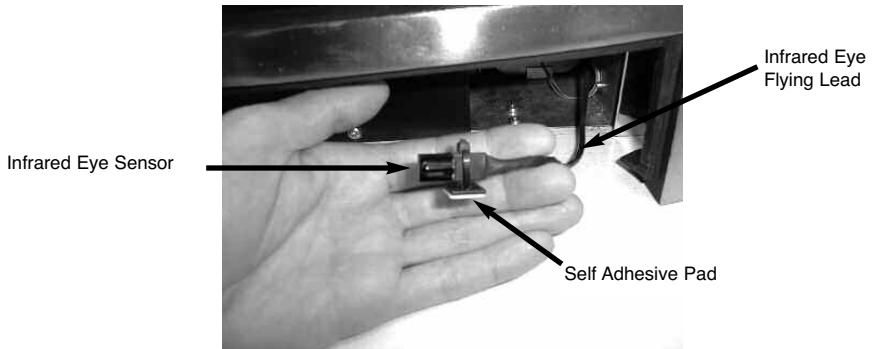

3.5.2 Remove the backing paper from the self adhesive pad and position the infrared eye in the air channels in the ashpan cover, so that the infrared eye is flush with the front edge of the ashpan cover, as shown below in Fig. 18. Check the operation of the fire / handset, as detailed in Section 3.7 and adjust the position of the infrared eye if necessary.

Fig. 18

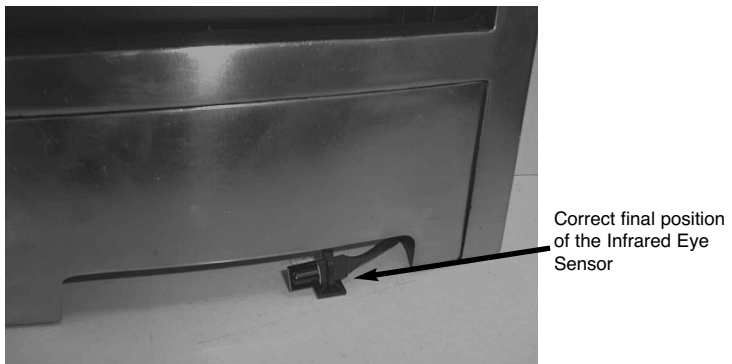

3.6 CONNECTING THE BATTERY PACK - REMOTE CONTROL & ELECTRONIC FIRE CONTROL MODELS ONLY.

- 3.6.1 To prevent un-necessary battery drain, the battery pack that is used to provide the remote and electronic control function for this product is disconnected at the factory. Prior to attempting to light the product, can the installer please ensure that the battery pack is re-connected as shown in section 3.6.2 & 3.6.3 below.
- 3.6.2 Locate the battery pack in the support cradle at the bottom R/H side of the firebox / burner assembly.
- 3.6.3 The wire and connecting plug from the battery pack should then be connected into the supply wire running from the control board. See Fig 19 below.

Fig. 19

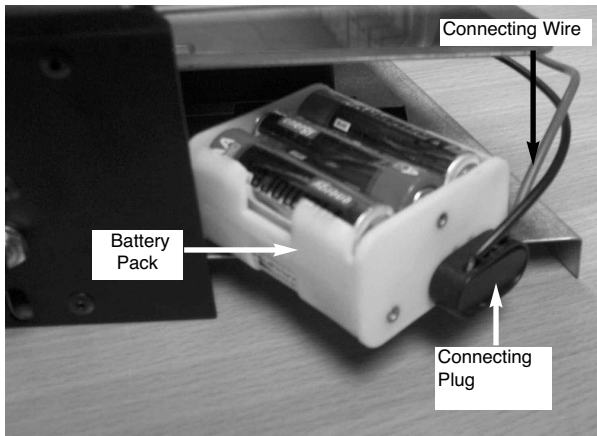

- 3.6.4 Replace the battery pack into its mounting cradle below the burner.
- 3.6.5 On RC models, fit the PP3 battery to the remote handset by removing the rear cover and connecting the battery to the connecting plug. Replace the cover on the handset.

3.7 LIGHTING THE APPLIANCE - REMOTE CONTROL MODELS ONLY

- 3.7.1 The Remote control handset generates an infrared signal, which will be received by the sensor situated at the front right of your fire, behind the ashpan cover. This infrared signal requires direct line of sight from the handset to the sensor on the fire to ensure good operation.
- 3.7.2 To light the appliance using the handset, point the handset at the fire and press the 2 left hand buttons together as shown below in Fig. 20. The fire will emit a “beep” sound, the buttons can now be released. After a few seconds an audible clicking can be heard and then the fire will light the pilot and then light the main burner. The ignition cycle will take approximately 20 seconds.
- 3.7.3 To reduce the level of heat input on the fire, point the handset at the fire and press the small flame button. (An audible beep will be heard)
- 3.7.4 To increase the level of heat input on the fire, point the handset at the fire and press the large flame button. (An audible beep will be heard)
- 3.7.5 To leave the fire in the standby mode (pilot only running) press the small round button on the handset.
- 3.7.6 To switch the appliance off completely, press the large round button on the handset, the fire will then switch off.

Fig. 20

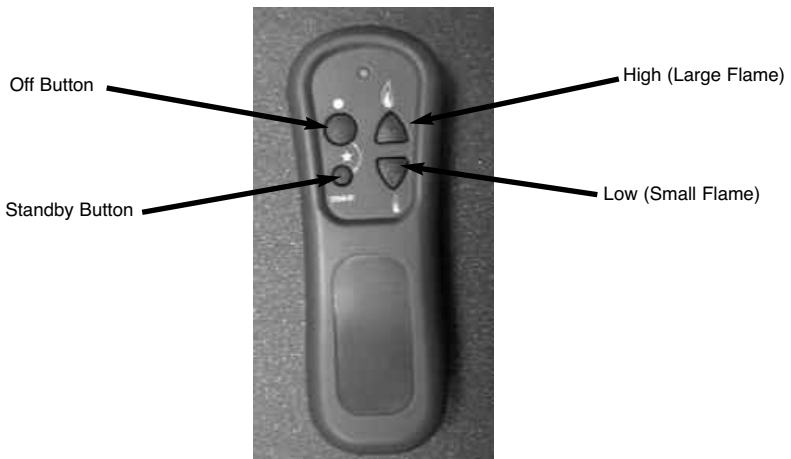

WHEN TURNING THE FIRE “OFF” PLEASE ENSURE THAT THE PILOT FLAME IS EXTINGUISHED. DO NOT LEAVE THE PILOT FLAME ONLY LIT.

3.8 LIGHTING THE APPLIANCE - ELECTRONIC FIRE CONTROL MODELS ONLY

- 3.8.1 To light the fire using the electronic fire control, press the ignition button as indicated below in Fig. 21. The fire will emit a “beep” sound, the buttons can now be released. After a few seconds an audible clicking can be heard and then the fire will light the pilot and then light the main burner. The ignition cycle will take approximately 20 seconds.
- 3.8.2 To reduce the level of heat input on the fire, press the small flame button on the trim switch. (An audible beep will be heard)
- 3.8.3 To increase the level of heat input on the fire, press the large flame button on the trim switch. (An audible beep will be heard)
- 3.8.4 To leave the fire in the standby mode (pilot only running) press the small round button on the trim switch. (An audible beep will be heard)
- 3.8.5 To switch the appliance off completely, press the Ignition / Off button on the trim switch, the fire will then switch off. (An audible beep will be heard)

Fig. 21

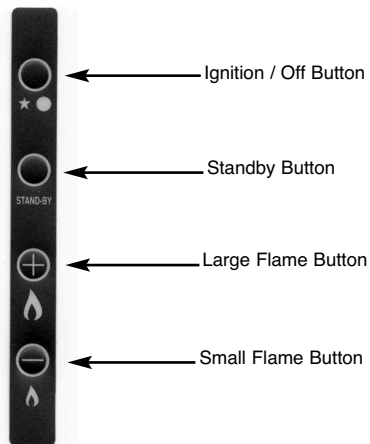

WHEN TURNING THE FIRE “OFF” PLEASE ENSURE THAT THE PILOT FLAME IS EXTINGUISHED. DO NOT LEAVE THE PILOT FLAME ONLY LIT.

SECTION 4 MAINTENANCE

Servicing Notes

Servicing should be carried out annually by a competent person such as a GAS SAFE registered engineer. It is a condition of the Verine guarantee schemes that this is carried out by a competent person i.e a GAS SAFE registered Engineer in accordance with these servicing notes

The condition of the coals should be checked and **if necessary the whole set should be replaced with a genuine replacement set.**

The burner assembly is designed to be removed as a complete unit for ease of access. **After any servicing work a gas tightness check must always be carried out.**

4.1 Removing the burner assembly from the fire (all models)

4.1.1 Remove ash-pan, fret assembly / trim or fascia from the front of the fire.

4.1.2 Isolate the gas supply, remove the glass frame as shown on in section 2.10 then remove the ceramics. Remove the 2 off fixing screws which hold the burner heat shield in place.

4.1.3 Remove the front ceramic support, which is held in position by 2 screws.

4.1.4 Loosen the burner pipe, which is situated behind the burner from the bulkhead fitting.

4.1.5 Remove the left and right hand burner retaining brackets, which are held in position by 2 screws.

4.1.6 Lift the burner assembly clear from the firebox.

4.1.7 Re-assemble in reverse order and carry out a gas tightness test.

4.2 Removing the piezo igniter (manual control models only)

4.2.1 Remove ash-pan, fret assembly / trim or fascia from the front of the fire.

4.2.2 Remove the 4 off screws which hold the control panel in place. Remove the 2 off fixing screws which hold the burner heat shield in place.

4.2.3 Remove the piezo retaining nut and disconnect the ignition wire

4.2.4 Replace the piezo and re-assemble in reverse order.

4.3 Removing the control valve from the fire (manual control models only)

4.3.1 Remove ash-pan, fret assembly / trim or fascia from the front of the fire.

4.3.2 Isolate the gas supply, remove the glass frame as shown on in section 2.10 then remove the ceramics. Remove the 2 off fixing screws which hold the burner heat shield in place.

4.3.3 Remove the 4 off screws which hold the control panel in place and the gas valve retaining nut.

4.3.7 Loosen and remove the three gas pipe retaining nuts from the control valve and release the ends of the gas pipes from the control valve body. Loosen and remove the thermocouple securing nut from the end of the control valve.

4.3.8 We do not recommend re-greasing or servicing of control valves. Defective valves should be replaced with a genuine replacement of the correct type.

4.3.9 To refit a control tap, re-assemble in the reverse order noting that the control tap locates on a flat in the control panel. Carry out a gas tightness test after re-assembly.

4.4 Removing the pilot assembly (manual & remote control models)

4.4.1 Remove ash-pan, fret assembly / trim or fascia from the front of the fire.

4.4.2 Isolate the gas supply, remove the glass frame as shown on in section 2.10 then remove the ceramics. Remove the 2 off fixing screws which hold the burner heat shield in place.

4.4.3 Loosen the pilot pipe, disconnect the ignition lead from the electrode, and remove the thermocouple from the pilot body.

4.4.4 Remove the two fixing screws which secure the pilot assembly to the mounting panel.

4.4.5 Remove the pilot assembly.

4.4.6 Re-assemble with an new pilot assembly, and gasket, ensuring than an even seal around the pilot assembly is obtained. Carry out a gas tightness test after re-assembly.

4.5 Removing the control board (remote & EFC models)

- 4.5.1 Remove ash-pan, fret assembly / trim or fascia from the front of the fire.
- 4.5.2 Isolate the gas supply, disconnect the gas control valve to bulkhead pipe and pilot / thermcouple connections to the pilot.
- 4.5.3 Pull controls sub assembly forward, disconnect wiring looms and remove 4 off screws which secure the control board to the controls sub assembly.
- 4.5.4 Replace in reverse order and carry out a gas tightness test.

4.6 Removing the control valve (remote & EFC models)

- 4.6.1 Remove ash-pan, fret assembly / trim or fascia from the front of the fire.
- 4.6.2 Isolate the gas supply, disconnect the gas control valve to bulkhead pipe and pilot / thermcouple connections to the pilot. Pull controls sub assembly forward, loosen and remove the three gas pipe retaining nuts from the control valve and release the ends of the gas pipes from the control valve body. Loosen and remove the thermocouple securing nut from the end of the control valve.
- 4.6.4 Replace in reverse order and carry out a gas tightness test.

4.7 Removing the infra-red sensor (remote control models)

- 4.7.1 Remove ash-pan, fret assembly / trim or fascia from the front of the fire.
- 4.7.2 Isolate the gas supply, disconnect the gas control valve to bulkhead pipe and pilot / thermcouple connections to the pilot.
- 4.7.3 Pull controls sub assembly forward, disconnect IR sensor lead from the control board. Replace in reverse order and carry out a gas tightness test.

4.8 Removing the battery holder & lead (remote & EFC models)

- 4.8.1 Remove ash-pan, fret assembly / trim or fascia from the front of the fire.
- 4.8.2 Isolate the gas supply, disconnect the gas control valve to bulkhead pipe and pilot / thermcouple connections to the pilot.
- 4.8.3 Pull controls sub assembly forward, disconnect battery holder / lead from the control board. Replace in reverse order and carry out a gas tightness test.

4.9 Removing the EFC trim switch

- 4.9.1 Remove ash-pan, fret assembly / trim or fascia from the front of the fire.
- 4.9.2 Isolate the gas supply, disconnect the gas control valve to bulkhead pipe and pilot / thermcouple connections to the pilot. Remove the fire from the opening.
- 4.9.3 Pull controls sub assembly forward, disconnect the trim switch lead from the control board, remove the EFC mounting frame from the fire.
- 4.9.4 Remove the EFC trim switch from mounting frame via the self adhesive pad, disconnect the wiring loom.
- 4.9.5 Replace in reverse order and carry out a gas tightness test.

4.10 Parts Shortlist

Replacement of parts must be carried out by a competent person such as a GAS SAFE registered gas installer. The part numbers of the replaceable parts are as follows, these are available from your local Verine Stockist, whose details may be found on the BFM Europe website, address as shown on the back page of this book.

Complete fuel-bed / ceramic set	B-130100
L/H front ceramic	B-130060
R/H front ceramic	B-130070
L/H rear ceramic	B-130080
R/H rear ceramic	B-130090
Glass panel	B-128040
EFC control switch	B-152610
EFC control switch lead	B-152650
RC gas control valve	B-106790
RC control board	B-129140
RC battery cable	B-106810
RC battery holder	B-106820
Piezo igniter	B-1320
NG manual gas valve	B-102880
LPG manual gas valve	B-102960
800mm extended flue duct (for use with NG models only)	CV-MARLT

SECTION FIVE - USER INSTRUCTIONS

5.1 INSTALLATION INFORMATION

CONDITIONS OF INSTALLATION

It is the law that all gas appliances are installed only by a competent (e.g. Registered) Installer, in accordance with the installation instructions and the Gas Safety (Installation and Use) Regulations 1998. Failure to install appliances correctly could lead to prosecution. It is in your own interest and that of safety to comply with the law.

The fire may be fitted below a combustible shelf provided that the shelf is at least 200mm above the top of the appliance and the depth of the shelf does not exceed 150mm.

The fire may be installed below combustible shelves which exceed 150mm deep providing that the clearance above the fire is increased by 15mm for each 25mm of additional overhang in excess of 150mm.

If this appliance is fitted directly on to a wall without the use of a fireplace or surround, soft wall coverings such as wallpaper, blown vinyl etc. could be affected by the heat and hot convection air and may discolour or scorch. This should be considered when installing or decorating.

The Model number of this appliance is as stated on the rating plate affixed to the control panel of the fire and the appliance is manufactured by:-

BFM Europe Ltd
Trentham Lakes
Stoke on Trent
ST4 4TJ

Please Note : The life span of the batteries in the burner unit on remote and electronic fire control models is dependent upon use and therefore the battery life will vary accordingly. If the burner unit fails to operate, please check the 6 off AA batteries before calling the service centre for engineer assistance.

ABOUT YOUR NEW VERINE ALPENA GAS FIRE

The Verine Alpena coal effect gas fire incorporates a unique and highly developed fuel bed which gives the realism of a loose coal layout combined with realistic flames and glow. The use of durable ceramic material in the construction of the fuelbed components ensures long and trouble free operation.

Please take the time to fully read these instructions as you will then be able to obtain the most effective and safe operation of your fire.

IMPORTANT SAFETY INFORMATION

WARNING

This is a heating appliance and as with all heating appliances a fireguard should be used for the protection of children, the elderly and infirm. Fireguards should conform to B.S. 8423 : 2002 (Fireguards for use with gas heating appliances).

It is important that this appliance is serviced at least once a year by a GAS SAFE registered gas installer. During the annual service, replacement of the pilot must be carried out. **This is a condition of the manufacturers guarantee.**

Any debris or deposits should be removed from the fuel bed from time to time. This may be carried out by referring to the cleaning section as described later in this book.

Only complete and genuine replacement fuel-bed sets must be used.

Always keep furniture and combustible materials well clear of the fire and never dry clothing or items either on or near to the fire. Never use aerosols or flammable cleaning products near to the fire when it is in use.

The ceramic fuel bed remains hot for a considerable period after use and sufficient time should be allowed for the fire to cool before cleaning etc.

DO NOT USE THIS FIRE UNDER ANY CIRCUMSTANCES IF THE GLASS PANEL IS CRACKED, BROKEN OR MISSING.

5.2 OPERATING THE FIRE (MANUAL CONTROL MODELS)

- 5.2.1 The controls are located behind the ashpan cover which is situated behind the Ashpan / Fender. The controls, comprise a control valve to adjust the gas flow and a push button piezo igniter.
To light the fire proceed as follows:-
- 5.2.2 Depress the control knob and turn anti-clockwise to the position marked pilot. Hold in the control knob for a few seconds to allow the gas to reach the pilot.
- 5.2.3 Continue to hold-in the control knob and press the igniter button. If the pilot does not light, continue to press the igniter button until ignition occurs. When the pilot has lit, continue to hold the control knob in for 5-10 seconds to allow the thermocouple to heat up, if the pilot goes out when the control knob is released, repeat the lighting sequence.
- 5.2.4 After lighting, turn the control knob in the anti-clockwise direction to the high position and the main burner will light. It is recommended that for most efficient performance the fire is allowed to warm up for a few minutes with the gas control on maximum.
- 5.2.5 The gas control can be turned clockwise from the maximum position to give the desired heat output.

WARNING

If the fire goes out for any reason or is turned off and it is necessary to re-light the fire it is important to allow the fire to cool for 5 minutes before attempting to re-light it.

WHEN TURNING THE FIRE “OFF” PLEASE ENSURE THAT THE CONTROL VALVE IS TURNED TO THE “OFF” POSITION AND THE PILOT FLAME IS EXTINGUISHED. DO NOT LEAVE THE PILOT FLAME ONLY LIT.

5.3 OPERATING THE FIRE (REMOTE CONTROL MODELS)

- 5.3.1 The Remote control handset generates an infrared signal, which will be received by the sensor situated at the front right of your fire, behind the ashpan cover. This infrared signal requires direct line of sight from the handset to the sensor on the fire to ensure good operation. If the handset is lost or broken, the fire can be lit manually, see the user instructions for details on how to operate the fire manually.
- 5.3.2 To light the appliance using the handset, point the handset at the fire and press the 2 left hand buttons together. The fire will emit a “beep” sound, the buttons can now be released. After a few seconds an audible clicking can be heard and then the fire will light the pilot and then light the main burner. The ignition cycle will take approximately 20 seconds.
- 5.3.3 To reduce the level of heat input on the fire, point the handset at the fire and press the small flame button once (An audible beep will be heard) and the heat input level will reduce to the low setting . Press and continually hold the small flame button and the fire will reduce incrementally to the low setting.
- 5.3.4 To increase the level of heat input on the fire, point the handset at the fire and press the large flame button. (An audible beep will be heard) and the heat input level will increase to the high setting Press and continually hold the small flame button and the fire will increase incrementally to the high setting.
- 5.3.6 To switch the appliance off completely, press the large round button on the handset, the fire will then switch off. See Fig. 1 below for image of handset.

Fig. 1

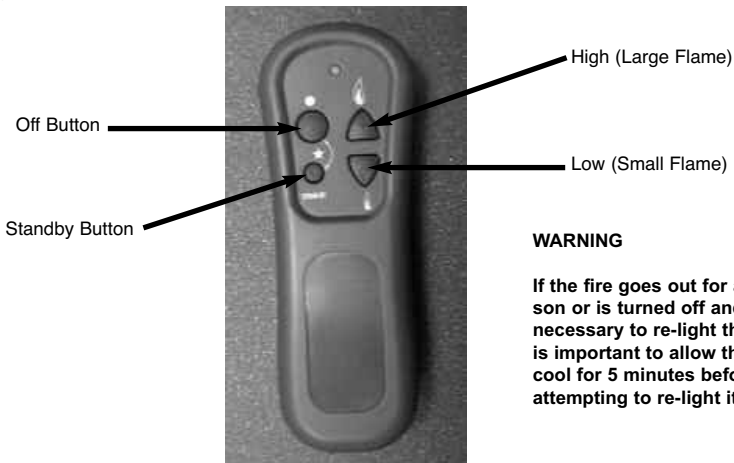

WHEN TURNING THE FIRE “OFF” PLEASE ENSURE THAT THE PILOT FLAME IS EXTINGUISHED. DO NOT LEAVE THE PILOT FLAME ONLY LIT.

5.4 LIGHTING THE APPLIANCE - ELECTRONIC FIRE CONTROL MODELS ONLY

- 5.4.1 To light the fire using the electronic fire control, press the ignition button as indicated below in Fig. 2. The fire will emit a “beep” sound, the buttons can now be released. After a few seconds an audible clicking can be heard and then the fire will light the pilot and then light the main burner. The ignition cycle will take approximately 20 seconds.
- 5.4.2 To reduce the level of heat input on the fire, press the small flame button on the trim switch. (An audible beep will be heard)
- 5.4.3 To increase the level of heat input on the fire, press the large flame button on the trim switch. (An audible beep will be heard)
- 5.4.4 To leave the fire in the standby mode (pilot only running) press the small round button on the trim switch. (An audible beep will be heard)
- 5.4.5 To switch the appliance off completely, press the Ignition / Off button on the trim switch, the fire will then switch off. (An audible beep will be heard)

Fig. 2

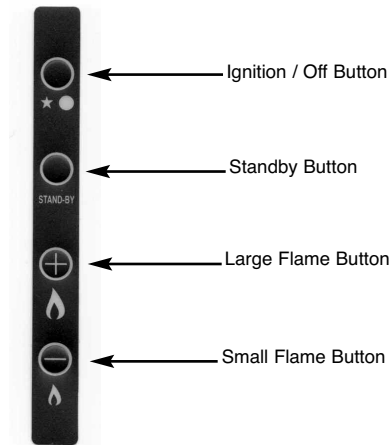

WHEN TURNING THE FIRE “OFF” PLEASE ENSURE THAT THE PILOT FLAME IS EXTINGUISHED. DO NOT LEAVE THE PILOT FLAME ONLY LIT.

5.5 TURNING THE PRODUCT OFF IN THE UNLIKELY EVENT OF A REMOTE HANDSET OR ELECTRONIC FIRE CONTROL MALFUNCTION.

- 5.5.1 In the unlikely event of the remote control handset malfunctioning (or if lost or broken) after the appliance has been turned on, the fire can be turned off via the emergency shut off switch on the control panel.
- 5.5.2 To turn the product off, firstly remove the ashpan from the fire.
- 5.5.3 Press and hold the emergency shut off switch until the fire shuts down. The process may take up to sixty seconds to complete. (see Fig. 3 below).
- 5.5.4 When the fire has shut down, release the emergency shut off switch.
- 5.5.5 The appliance will now remain in the “off” position until activated by the remote handset.

PLEASE NOTE : THERE IS NO MANUAL OVER-RIDE FACILITY FOR THE REMOTE CONTROL SYSTEM AND THE EMERGENCY SHUT OFF SWITCH SHOULD ONLY BE ACTIVATED IF YOU ARE SURE THE REMOTE HANDSET OR EFC CONTROL IS MALFUNCTIONING, DAMAGED OR LOST.

Fig. 3

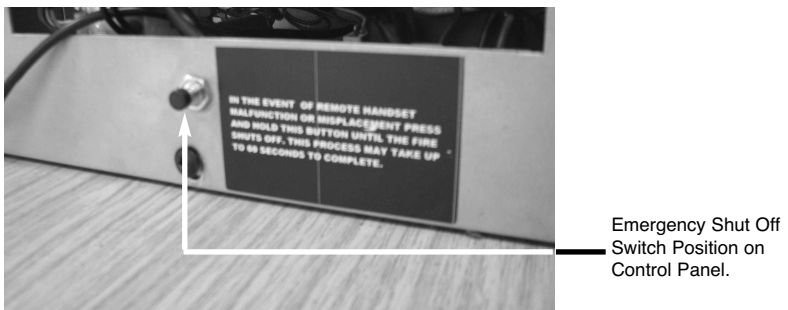

5.6 REPLACING THE BATTERIES (REMOTE & EFC MODELS ONLY)

ENSURE THE FIRE IS COOL BEFORE REPLACING BATTERIES

Remove the ashpan cover. The battery pack is located on the right hand side side of the burner unit at the bottom. Carefully remove the pack and remove batteries. Replace in the reverse order using 6 off 1.5V AA Alkaline Battery. **It is important that only an alkaline batteries are used, otherwise premature battery failure and leakage may result.** Fit the PP3 battery to the remote handset by removing the rear cover and connecting the battery to the connecting plug. Replace the cover on the handset.

5.7 REMOVAL / REPLACING THE GLASS FRAME

- 5.7.1 Remove the 2 screws which hold the convection slot cover to the firebox, as shown below in Fig. 4
- 5.7.2 Remove the burner heat shield by unscrewing the 2 off retaining screws as shown below in Fig. 4
- 5.7.3 Remove the 4 off retaining nuts as shown below in Fig. 4
- 5.7.4 Remove the 3 off top retaining screws as shown below in Fig. 4
- 5.7.5 Remove the 2 off bottom retaining screws as shown below in Fig. 4
- 5.7.6 Re-assemble in reverse order.

NOTE : Always ensure that a consistent seal between the combustion chamber and the glass frame is achieved.

Fig. 4

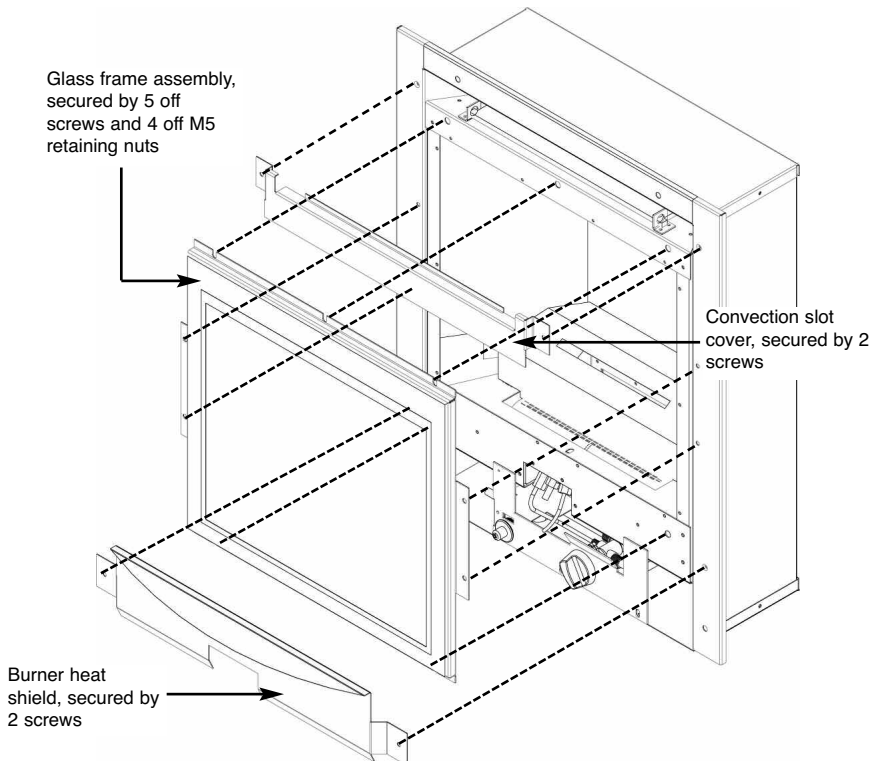

5.8 REMOVING / REPLACING THE FUELBED

5.8.1 Place the ceramic fibre support behind the burner as shown below in Fig. 5

Fig. 5



5.8.2 Place the front right coal moulding onto the front coal support as shown below in Fig. 6

Fig. 6

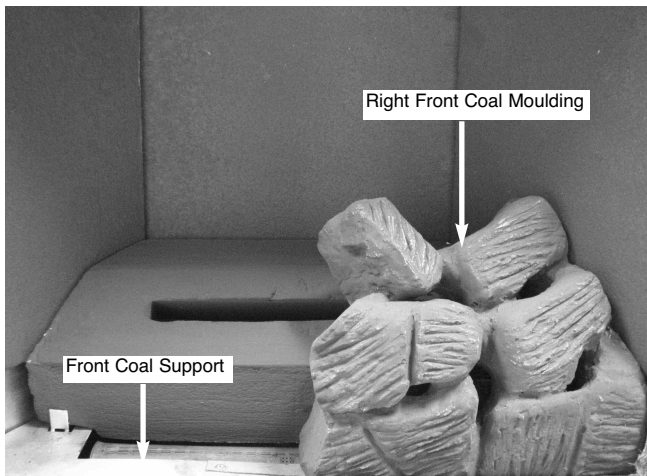

5.8.3 Place the front left coal moulding onto the front coal support as shown below in Fig. 7

Fig. 7

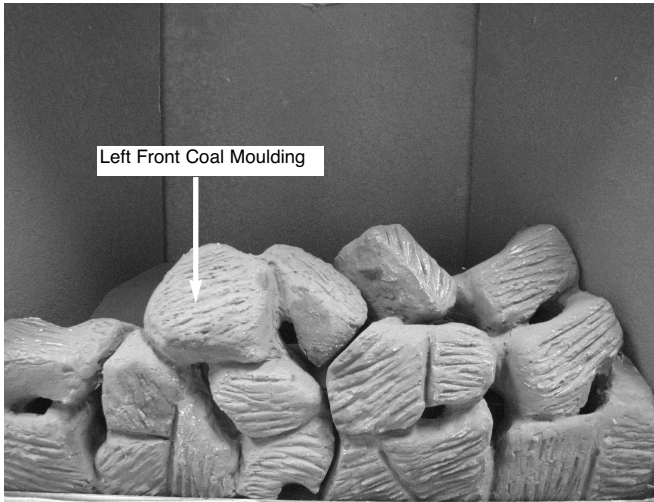

5.8.4 Place the upper right coal moulding as shown below in Fig. 8. This moulding tucks under the front right coal moulding and is supported by the ceramic fibre support.

Fig. 8

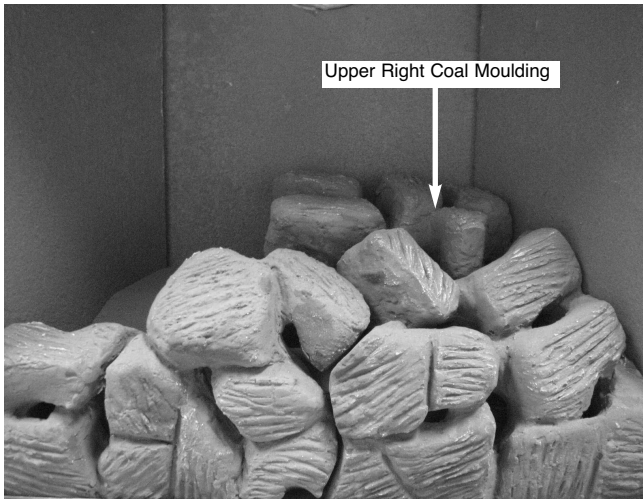

- 5.8.5 Place the upper left coal moulding as shown below in Fig. 9. This moulding tucks under the front left coal moulding and is supported by the ceramic fibre support.

Fig. 9

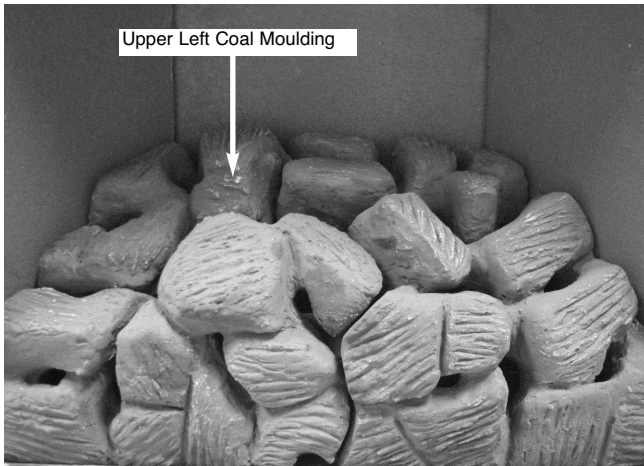

- 5.8.6 Refit the glass frame as detailed in section 5.7, then light the appliance as detailed in section 5.2 / 5.3 / 5.4

To ensure that the release of fibres from these R.C.F (Refractory Ceramic Fibre) articles is kept to a minimum, during installation and servicing we recommend that you use a HEPA filtered vacuum to remove any dust accumulated in and around the appliance before and after working on the appliance. When replacing these articles we recommend that the replaced items are not broken up, but are sealed within heavy duty polythene bags, clearly labelled as “RCF waste”. RCF waste is classed as a “stable”, non reactive hazardous waste and may be disposed of at a landfill licensed to accept such waste Protective clothing is not required when handling these articles, but we recommend you follow the normal hygiene rules of not smoking, eating or drinking in the work area, and always wash your hands before eating or drinking.

5.9 User Replaceable Parts

Complete fuel-bed / ceramic set	B-130100
L/H front ceramic	B-130060
R/H front ceramic	B-130070
L/H rear ceramic	B-130080
R/H rear ceramic	B-130090

Due to our policy of continual improvement and development the exact accuracy of illustrations and descriptions contained in this book cannot be guaranteed.

**Part No. B-129900
Issue 7**

V E R I N E
FIRES ✦ TO ✦ INSPIRE

BFM Europe Ltd.
Trentham Lakes
Stoke-on-Trent
Staffordshire
ST4 4TJ

www.bfm-europe.com

Telephone - General Enquiries : (01782) 339000
Telephone - Service : (0844) 7700169