



Fire Your Imagination

Studio

Balanced Flue with Thermostatic Remote Control



IMPORTANT:
FOR EASY TO FOLLOW,
STEP BY STEP VIDEO
INSTRUCTIONS ON HOW TO
OPERATE AND MAINTAIN YOUR
GAZCO REMOTE SYSTEM GO TO
WWW.GAZCO.TV

Instructions for Use, Installation & Servicing

For use in GB & IE (Great Britain & Republic of Ireland).

IMPORTANT

THE OUTER CASING, FRONT AND GLASS PANEL BECOME EXTREMELY HOT DURING OPERATION AND WILL RESULT IN SERIOUS INJURY AND BURNS IF TOUCHED. IT IS THEREFORE RECOMMENDED THAT A FIREGUARD COMPLYING WITH BS 8423:2002 IS USED IN THE PRESENCE OF YOUNG CHILDREN, THE ELDERLY OR INFIRM.

This product contains a heat resistant glass panel. This panel should be checked during Installation and at each servicing interval. If any damage is observed on the front face of the glass panel (scratches, scores, cracks or other surface defects), the glass panel must be replaced and the appliance must not be used until a replacement is installed. Under no circumstances should the appliance be used if any damage is observed, the glass panel is removed or broken.

These Instructions must be left with the appliance for future reference and for consultation when servicing the appliance. Please make the customer aware of the correct operation of the appliance before leaving these instructions with them.

The commissioning sheet found on Page 3 of this Instruction manual must be completed by the Installer prior to leaving the premises.

Contents

Studio Balanced Flue

Covering the following models:

STUDIO 1 BALANCED FLUE	STUDIO 2 BALANCED FLUE	STUDIO 3 BALANCED FLUE
123-309	123-162	123-032
123-558	123-676	123-514
123-180	123-228	123-393
123-621	123-713	123-446
123-018	123-252	123-047
123-437	123-682	123-649

Appliance Commissioning Checklist3

User Instructions4

Installation Instructions16

Technical Specifications - Stone Chippings Version 16

Technical Specifications - Log Version 17

Site Requirements20

Installation24

Commissioning39

Servicing Instructions.....40

Fault Finding 40

How To replace Parts 43

Basic Spare Parts List - Stone Chippings 50

Basic Spare Parts List - Log Version 51

Service Records52



To receive your Extended Warranty your Gazco appliance must have been purchased from our Expert Retailer Network and registered within one month of purchase or installation. Please note that all warranties are effective from the date of purchase. Any Gazco product purchased outside of our Extended Retailer Network, or not registered within the stated time will carry a standard 12 month warranty.

It is a condition of the Extended Warranty that the installation complies with the relevant Building Regulations and is carried out by a suitably trained and qualified individual (GasSafe in the UK or equivalent in other countries) with the certificate of installation and the Commissioning Report on Page 3 completed and retained by the end user.

Full terms and conditions are detailed in the Warranty Statement on the Gazco website www.gazco.com. In the event of any conflict of information the wording on the website shall prevail.

Important Note: Should any problems be experienced with your product, claims must first be submitted to the Expert Retailer where the appliance was purchased from who will offer immediate assistance or contact Gazco on your behalf.

Appliance Commissioning Checklist

To assist us in any guarantee claim please complete the following information:-

IMPORTANT NOTICE

Explain the operation of the appliance to the end user, hand the completed instructions to them for safe keeping, as the information will be required when making any guaranteed claims.

FLUE CHECK	PASS	FAIL
1. Flue Is correct for appliance		
2. Flue flow Test N/A		
3. Spillage Test n/a		
GAS CHECK		
1. Gas soundness & let by test		
2. Standing gas pressure	mb	
3. Appliance working pressure (on High Setting NB All other gas appliances must be operating on full	mb	
4. Gas rate	m ³ /h	
5. Does Ventilation meet appliance requirements N/A		

RETAILER AND INSTALLER INFORMATION

Retailer	Installation Company
.....
.....
Contact No.	Engineer
Date of Purchase	Contact No.
Model No.	Gas Safe Reg No.
Serial No.	Date of Installation
Gas Type	

User Instructions

Welcome

Congratulations on purchasing your Studio fire, if installed correctly Gazco hope it will give you many years of warmth and pleasure for which it was designed.

The purpose of this manual is to familiarise you with your appliance and give guidelines for its installation, operation and maintenance. If, after reading, you need further information, please do not hesitate to contact your Gazco retailer.

WARNING



In the event of a gas escape or if you can smell gas, please take the following steps:

- Immediately turn off the gas supply at the meter/emergency control valve
- Extinguish all sources of ignition
- Do not smoke
- Do not operate any electrical light or power switches (On or Off)
- Ventilate the building(s) by opening doors and windows
- Ensure access to the premises can be made

Please report the incident immediately to the National Gas Emergency Service Call Centre on 0800 111 999 (England, Scotland and Wales) , 0800 002 001 (N. Ireland) or in the case of LPG, the gas supplier whose details can be found on the bulk storage vessel or cylinder.

The gas supply must not be used until remedial action has been taken to correct the defect and the installation has been recommissioned by a competent person.

1. General

- 1.1 Installation and servicing must only be carried out by a competent person whose name appears on the Gas Safe register. To ensure the engineer is registered with Gas Safe they should possess an ID Card carrying the following logo:



- 1.2 In all correspondence, please quote the appliance type and serial number, which can be found on the data badge located on a plate attached to the lower slotted trim.
- 1.3 **Do not** place curtains above the appliance: You must have 300mm (1') clearance between the appliance and any curtains at either side.

- 1.4 No furnishings or other objects should be placed within 1 metre of the front of the appliance.
- 1.5 If a shelf is fitted, a distance of 400mm above the appliance is required.
- 1.6 If any cracks appear in the glass panel do not use the appliance until the panel has been replaced.
- 1.7 Do not obstruct the flue terminal in any way, i.e. by planting flowers, trees, shrubs etc. in the near vicinity, or by leaning objects against the terminal guard.
- 1.8 Do not put any objects on the terminal guard; it will lose its shape.
- 1.9 If you use a garden sprinkler, do not let quantities of water into the flue terminal.
- 1.10 In the unlikely event the appliance is receiving interference from other electronic devices, the handset/Control box can be reprogrammed. Please refer to the commissioning section in order to change the communication channel.
- 1.11 This product is guaranteed for 5 years from the date of installation, as set out in the terms and conditions of sale between Gazco and your local Gazco retailer. Please consult with your local Gazco retailer if you have any questions. In all correspondence always quote the Model Number and Serial Number.



IMPORTANT : NEVER position an LCD/Plasma TV above this appliance.

2. Control Options

- 2.1 The appliance has 4 flame settings:
1. High.
 2. Medium.
 3. Low.
 4. Standby (Pilot only).
- 2.2 Both touch pad and handset allow you to manually switch between flame settings.
- 2.3 The Thermostatic handset also allows to set the appliance to automatically regulate the room temperature.

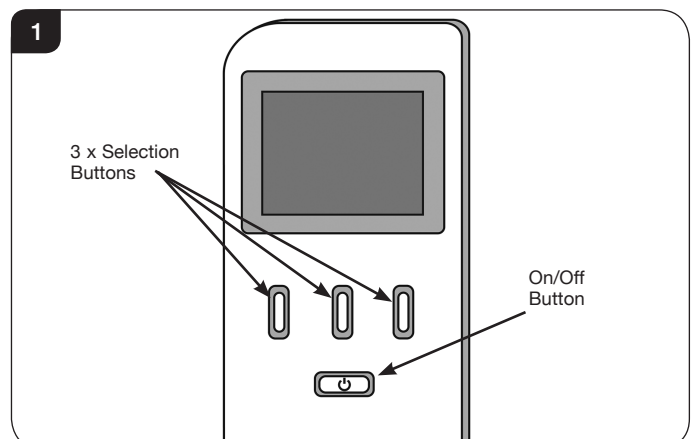

User Instructions

Before using the remote control:

- 2.4 If there is no display on the LCD screen press any key.
- 2.5 When first powered, the handset displays the OFF screen. The handset may be locked as indicated by the padlock symbol (🔒), see Diagram 2.

NOTE: To select a function from the options displayed at the bottom of the screen press the button directly below the desired function.

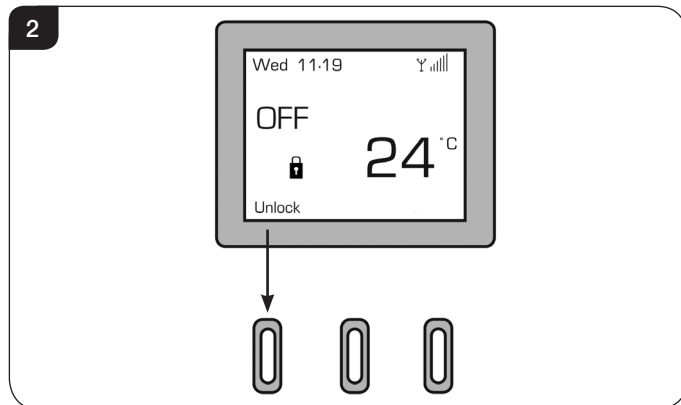

- 2.6 To unlock the handset select Unlock followed by OK - the symbol will change to an open padlock (🔓).
- 2.7 There are 3 different modes available for controlling and operating the appliance:
1. Manual Mode - See Page 6.
 2. Automatic Mode - See Page 6.
 3. Program Mode - See Page 7.

When a command from the handset is received a beep will sound and the LED on the handset will briefly illuminate.

NOTE: The LED flashes every 4 seconds to show that it is communicating with the appliance. After each command has been accepted the LED will cease flashing until the command has been carried out. Wait until the LED resumes flashing before giving another command.

Advanced Controls

- 2.8 The thermostatic remote control handset has been pre-set as follows:
- a) Thermostat mode - the appliance will alter automatically to achieve and maintain a desired room temperature in Auto (Fixed Temp) or Program mode.
 - b) Gap temperature set at 2°C - in Auto or Program mode the appliance will automatically ignite if the room temperature falls 2°C below the fixed temperature.
 - c) Program mode enabled - this allows one of three temperatures (Night temperature, Comfort temperature or Off) to be set for each hour of the day on a daily or weekly cycle.

d) Soft start enabled - in Auto or Program mode there is a 10 second delay between flame settings when more than one change of setting is required (i.e. from High to Low).

e) Sounder ON - the appliance will beep to confirm that it has received a command from the handset or touch pad.

f) Safety Temperature pre-set at 40°C - the appliance will automatically switch off if the room temperature (as displayed on the handset) exceeds 40°C.

NOTE: If the Safety Temperature is exceeded the appliance can not be turned on again until the room temperature has dropped below the safety temperature.

2.9 The LCD screen displays the following information, see Diagram 3.

- 1) Time (24 hr clock)
- 2) Signal strength (between handset and appliance)
- 3) Selected Setting - set fixed temperature (in degrees) when in Auto mode (small number)
- 4) Current room temperature (large number)
- 5) Button function
- 6) Child lock status (shown by open or closed padlock)
- 7) Current flame status (Low, Med, High)
- 8) Selected Mode - Manual Flame / Fixed Temp (Auto) / Program - when appliance is switched on
- 9) Day of the week (Mon - Sun)

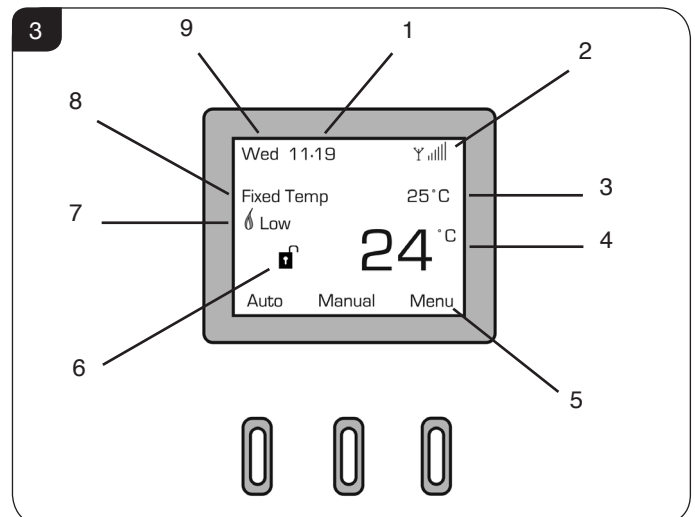

1. Manual Mode

Switching the Appliance ON:

- 2.10 To light the appliance press the On/Off (⏻) button, this will bring up the LCD screen. Select the 'On' option on the left of the screen immediately followed directly by the OK button, a single beep will sound.

User Instructions

After the start up cycle has completed the appliance will light on the high flame setting (this can take up to 20 seconds).

Select the 'Manual' option on the screen to control the appliance.

Decreasing the Flame Height:

- 2.11 From the high flame setting press DOWN (↓) once to lower the flame to the medium setting.
- 2.12 From the medium flame setting press DOWN (↓) once to lower the flame to the low setting.
- 2.13 From the low flame setting press DOWN (↓) once to put the appliance in Standby mode (Pilot only).

Increasing the Flame Height:

- 2.14 To light the appliance when it is in Standby mode press UP (↑) once. The appliance will light on the **Low** flame setting.
- 2.15 From the low setting press UP (↑) once to increase the flame setting to medium.
- 2.16 From the medium setting press UP (↑) once to increase the flame setting to high.



WARNING: IF THE APPLIANCE FAILS TO LIGHT OR BECOMES EXTINGUISHED IN USE, WAIT 3 MINUTES BEFORE ATTEMPTING TO RELIGHT.



IMPORTANT: YELLOW FLAMES TYPICALLY APPEAR WHEN THE APPLIANCE HAS REACHED NORMAL OPERATING TEMPERATURE. THIS CAN TAKE UP TO 30 MINUTES.

Switching the Appliance OFF:

- 2.17 To switch the appliance OFF press the On/Off (⏻) button once, see Diagram 1.

2. Automatic Mode

Auto mode allows you to pre-set a room temperature. The appliance controls the flame setting automatically to achieve and maintain this temperature.

NOTE: WHEN IN AUTOMATIC MODE, THE PILOT REMAINS LIT AND THE MAIN BURNER AUTOMATICALLY ADJUSTS TO MAINTAIN THE FIXED TEMPERATURE WHETHER OR NOT ANYONE IS IN THE ROOM.

- 2.18 If the appliance is switched off, select On followed by OK. The appliance will emit a single beep and the pilot will light.
- 2.19 Select Auto. The screen will display the word 'Thermo' and the current fixed room temperature will be highlighted.
- 2.20 Use the buttons directly below the up (↑) or down (↓) symbols to select a temperature between 0°C and 37°C.

The flame setting required to achieve the desired room temperature will now be displayed below the word 'Thermo'.

- 2.21 The appliance will maintain the fixed temperature by automatically adjusting the flame height as follows:
 - a) If the room temperature falls 1°C below the fixed temperature the flame height will increase.
 - b) If the room temperature rises 1°C above the fixed temperature the flame height will decrease.
 - c) There will be a delay of 10 seconds between each flame setting adjustment.
- 2.22 Once the desired room temperature has been set, select Back to return to the main screen.
- 2.23 The screen will now display the words 'Fixed Temp', the chosen fixed temperature (e.g. 25°C) and the current room temperature (e.g. 24°C), see Diagram 4.

4

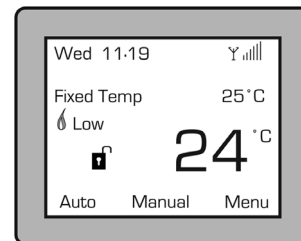

- 2.24 To change the fixed temperature at any time select Auto and follow 2.20.
- 2.25 To exit the Auto mode at any time select Manual and follow Section 2.22.
- 2.26 To turn off the appliance press the ON/OFF button once, see Diagram 2.

Setting the Display

Items displayed on the main screen, such as day and time, can be set using the Adjust Menu function.

- 2.27 To access the Adjust Menu function select Menu from the main screen.
- 2.28 Select Adjust Menu.
In this menu it is possible to set the:
 - Temperature Unit (°C/°F)
 - Language
 - Autolock (On/Off)
 - Day (Mon - Sun)
 - Hour (24hr clock)
 - Minute
 - Comfort temperature (for use when in Program mode)
 - Night temperature (for use when in Program mode)

Access can be gained to the programmable functions via the Change Prog option (see Programming the Appliance).

Setting the Day and Time:

- 2.29 Use (↓) to scroll down to Day and press Select. Use (↑) and (↓) to set the day of the week.

User Instructions

- 2.30 Press Back and scroll down to Hour and select it. Use (↑) and (↓) to set the hour.
- 2.31 Press Back and scroll down to Minute and press Select. Use (↑) and (↓) to set the minutes.
- 2.32 The same process can be used to set any of the functions within this menu.

3. Program Mode

Program mode allows the appliance to be pre-set to a choice of temperature options on a daily or weekly cycle. The appliance will automatically switch on and off and control the flame setting to maintain pre-set hourly temperatures during each 24hr period.

NOTE: WHEN IN PROGRAM MODE, THE PILOT REMAINS LIT AND THE MAIN BURNER AUTOMATICALLY SWITCHES ON AT THE PROGRAMMED TIMES AND ADJUSTS THE FLAME HEIGHT TO BRING THE ROOM TO THE SET TEMPERATURE WHETHER OR NOT ANYONE IS IN THE ROOM.

Note: The current day and time must be set in order for the programmable functions to work. (See Section 2.28 for details).

- 2.33 There are two types of program mode:
 1. Daily - the temperature can be set for each hour over a 24hr period - This pattern is then repeated every day.
 2. Weekly - the temperature can be set for each hour over a 24hr period for each individual day of the week (Mon - Sun). This pattern is then repeated every week.
- 2.34 One of 3 options can be chosen for each hour across a 24 hour period:
 - Off - the appliance will remain in Standby mode (pilot only). **The appliance will not switch off completely when in Program mode.**
 - Night Temp - the appliance will automatically maintain a pre-set night temperature.
 - l Comfort Temp - the appliance will automatically maintain a pre-set comfort temperature.
- 2.35 To set the Comfort and Night temperature select Menu. In the next screen select Adjust Menu. Using (↓) scroll to Comfort Temperature and select. Use (↑) and (↓) to set a chosen temperature. Repeat for Night Temperature.
- 2.36 To access the programming screen select Menu. In the next screen select Adjust Menu. Using (↓) scroll to Change Prog and select. The programming screen will be displayed as shown in Diagram 5.

Setting Daily Operating Times:

- 2.37 In the program menu highlight the word 'Daily'. Press (↓) to access the 24 hour timer below 'Daily'. The arrow should now point to the right (→).
- 2.38 The timer reads 0 - 24 with both 0 and 24 representing midnight. Press (→) to scroll through the 24 hour timer. With the cursor resting on the chosen hour, press Change until the desired setting for that hour (Comfort Temperature, Night Temperature or Off) is reached. Use (→) to scroll to the next hour and select the desired function for each hour until all 24 hours are set, see Diagram 6.

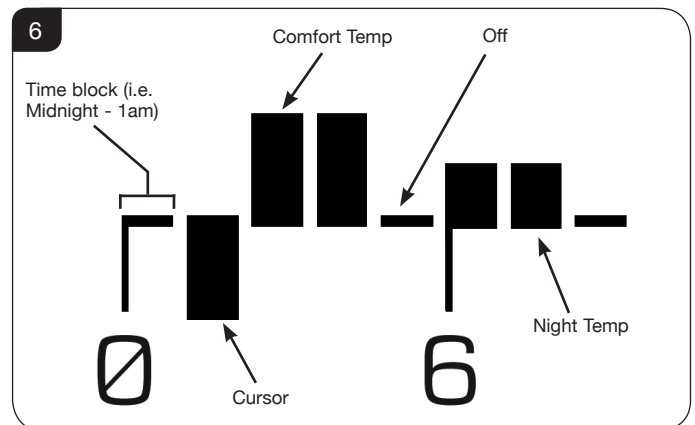

- 2.39 The program must now be launched. To do to this see Section 2.44.

Setting Weekly Operating Times:

- 2.40 Access the programming screen as detailed in Section 2.36. The word 'Daily' will be highlighted. Select 'Change' to scroll from 'Daily' to the required day of the week (Monday - Sunday).
- 2.41 Press (↓) to access the timer. Select the function settings for each hour of the chosen day as detailed in 2.40. Repeat for the rest of the week.
- 2.42 Once the programming is completed select Back to return to the main screen.
- 2.43 The program must now be launched. To do to this see 2.44.

Launching a Daily or Weekly Program:

- 2.44 Select Menu. In the next screen use (↓) to scroll to Program and confirm. Select Change until the highlighted text reads ON.

Note: The appliance must be ON (pilot lit or any flame setting) in order to launch the program.

- 2.45 Select Back and use (↓) to select Prog Type. Select Change until the desired program (Daily or Weekly) is highlighted. Select Back twice to return to the main screen.

5

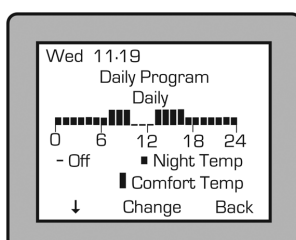

User Instructions

To Switch Off Program Mode

- 2.46 To switch off the set program select Stop from the options on the main screen. The appliance will switch to Stand-by (pilot only). Alternatively select Auto; this will end the program cycle and return to the main screen. The appliance will automatically adjust the flame height to maintain any previously set Fixed Temperature.

Locking the Handset

- 2.47 To lock the handset Select Lock. If the option is not visible on the screen (i.e. when the appliance is lit) select Menu and scroll down to Lock. Press Select and use the Change function to scroll to Yes. The handset is now locked.

3. Replacing the Handset Batteries

- 3.1 **BEFORE USE:**
Ensure the remote handset contains 2 x AA 1.5v alkaline batteries (provided). Always replace the batteries with high quality batteries (Duracell or similar).
DO NOT USE RECHARGEABLE BATTERIES.
- 3.2 Communication between the handset and the appliance may take up to 2 minutes after batteries have been replaced, check the strength of the signal in the top right hand corner of the LCD display (Y||||).
- 3.3 If communication is not regained after this time the control unit and the handset may need pairing. Please refer to Commissioning, Section 2, Pairing the Appliance.

4. Handset Troubleshooting



IMPORTANT - THE CONTROL SYSTEM HAS BEEN PROGRAMMED TO CHANNEL 'C'. SOME HOUSEHOLD APPLIANCES MAY HAVE ALSO BEEN SET TO OPERATE ON THE SAME FREQUENCY. ALTHOUGH THIS HAS NO EFFECT ON THE SAFETY OF THE SYSTEM AN EXCESSIVE DELAY MAY BE ENCOUNTERED BETWEEN COMMANDS. IF THIS OCCURS FOLLOW THE INSTRUCTIONS IN COMMISSIONING SECTION 3 TO CHANGE THE CHANNEL.

CHANNEL SETTINGS

- 4.1 The appliance has been factory set to only communicate with the handset it is supplied with. It will not respond to any other remote control, even one from an identical appliance.

A replacement handset will need to be paired with the appliance before use. Please refer to Commissioning, Section 2, Pairing the Appliance.

LOW BATTERY

- 4.2 If the batteries in the remote control handset become discharged the LCD display will show the message Low Battery.

Follow Section 3 - Replacing The Handset Batteries.

REMOTE SIGNAL STRENGTH



NOTE: If the handset is taken out of range the signal strength indicator will show 'Loss of Signal'. When the handset is returned to the appliance it will be necessary to press any button and wait for the signal indicator to recognise the handset. This can take up to 4 minutes

- 4.3 If the appliance does not respond to the handset, check the strength of the signal in the top right hand corner of the LCD display (Y||||).

No vertical bars next to the signal symbol (Y) means communication between the appliance and the handset has been lost. If the communication loss exceeds 18 minutes the appliance will emit 20 beeps and switch OFF. Try the following:

- 4.4 Move the handset closer to the appliance.
- 4.5 Replace the batteries in the handset, see Section 3.
- 4.6 If there is still no signal, operate the appliance using the touch pad control, see Section 5 and consult your installer or Gazco retailer.

5. Touch Pad Control

7



The touch pad control is located on the front of the wall switch and allows manual operation of the appliance, see Diagram 7.

With the touch pad it is possible to turn the appliance ON, OFF and control the flame setting.

NOTE: When using the touch pad buttons a beep will be emitted from the appliance to indicate an accepted command.

Lighting the appliance

- 5.1 Press the On/Off button once.

If the pilot fails to light, press the ON/OFF button to switch OFF. Wait for at least 30 seconds before attempting to relight.

- 5.2 After the start up cycle has completed the appliance will light on the **high flame setting** (this can take up to 20 seconds).

User Instructions

If the appliance is in Standby mode, pressing the UP (^) button will cause the main burner to ignite on the **Low** flame setting.

- 5.3 To increase the flame height press the UP (^) button.
- 5.4 To decrease the flame height press the DOWN (v) button.
- 5.5 When on the lowest flame setting pressing the Down (v) button will switch the appliance to Standby mode (pilot only).

WARNING: IF THE APPLIANCE FAILS TO LIGHT OR BECOMES EXTINGUISHED IN USE, WAIT 3 MINUTES BEFORE ATTEMPTING TO RELIGHT.

IMPORTANT: YELLOW FLAMES TYPICALLY APPEAR WHEN THE APPLIANCE HAS REACHED NORMAL OPERATING TEMPERATURE. THIS CAN TAKE UP TO 30 MINUTES.

To Switch the Appliance OFF:

- 5.6 To turn the appliance **OFF** press the On/Off button once.

Touch Pad Control Not Working

If the appliance is not operating with the touch pad control:

- 5.7 Replace the batteries in the wall switch unit, see Section 6.
- 5.8 If the appliance still fails to operate consult your installer or Gazco retailer.

6. Changing the Appliance Batteries

The appliance batteries are located behind the wall switch plate.

- 6.1 Undo the two screws securing the wall plate and gently bring it forward to expose the wires behind. Keep the wall plate supported, taking care not to put any strain on the wires, see Diagram 8.

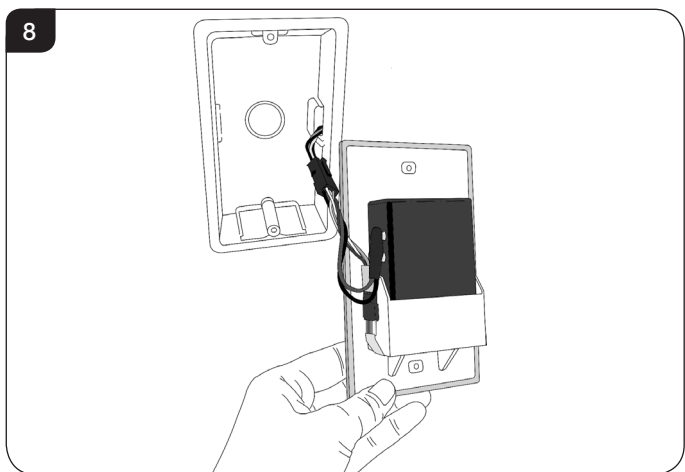

- 6.2 Whilst supporting the wall plate remove the battery holder from its location, see Diagram 9.

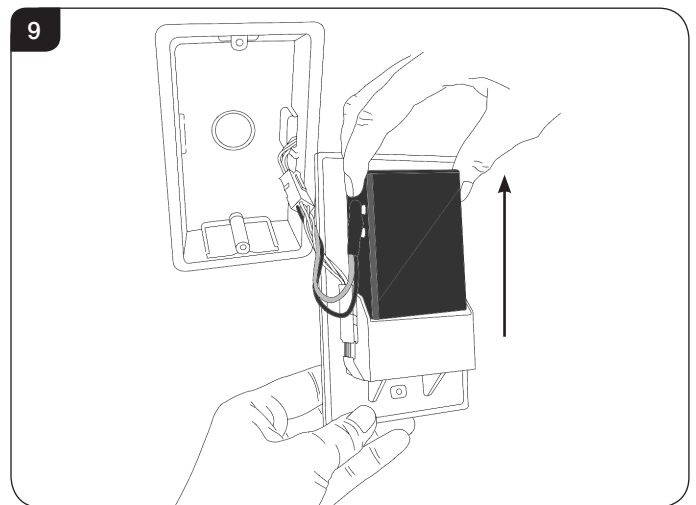

- 6.3 If it is not possible to support the wall plate and battery holder at the same time separate the wall plate from the dry lining box by disconnecting the plug as shown, see Diagram 10. Press the top of the clip on the upper section to release.

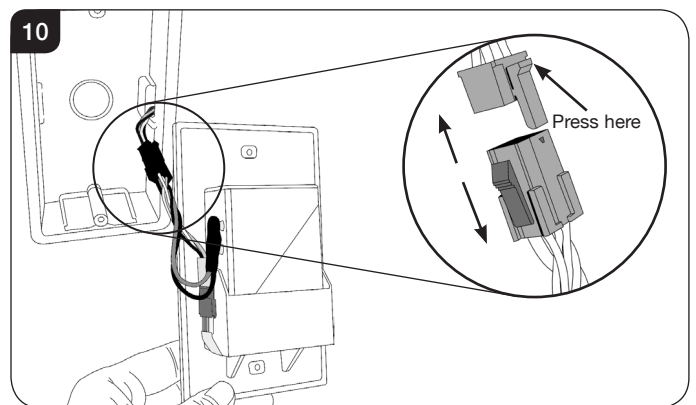

- 6.4 Flip the battery holder over end to end and remove the cover by sliding off in the direction of the arrow shown in Diagram 11.

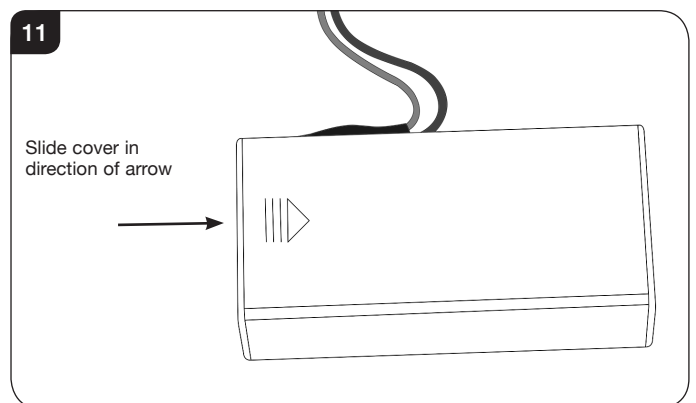

- 6.5 Remove the old batteries and correctly position the three new high quality (Duracell or similar) size C batteries into the battery holder, see Diagram 12.

User Instructions

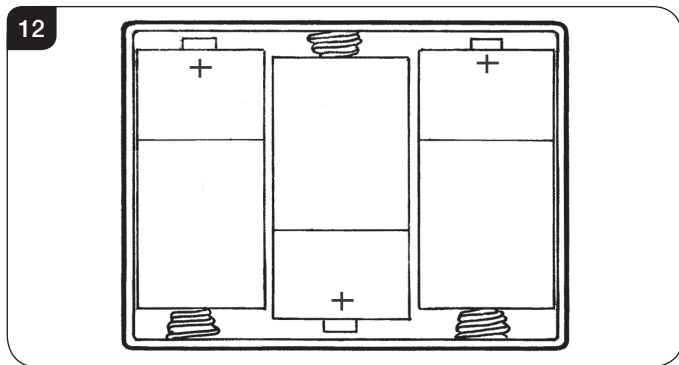

6.6 Re-assemble in reverse.

PLEASE ENSURE NO WIRES ARE TRAPPED BEFORE REPLACING THE WALL PLATE. THE TOUCH PAD LEAD IS EASILY DAMAGED.

7. Cleaning the Studio

7.1 Make sure the appliance and surrounds are cool before cleaning.

7.2 Use:

- A damp cloth for the painted frame.
- A damp cloth to clean the granite/enamelled inner panels.
- Soap and water to clean the glass.

Opening the Glass Window:

7.3 **Steel, Verve or Glass Frame**

If fitted with a Steel, Verve or Glass Frame, this needs to be removed first:

7.4 Lift the frame upwards off its four support brackets, see Diagram 13.

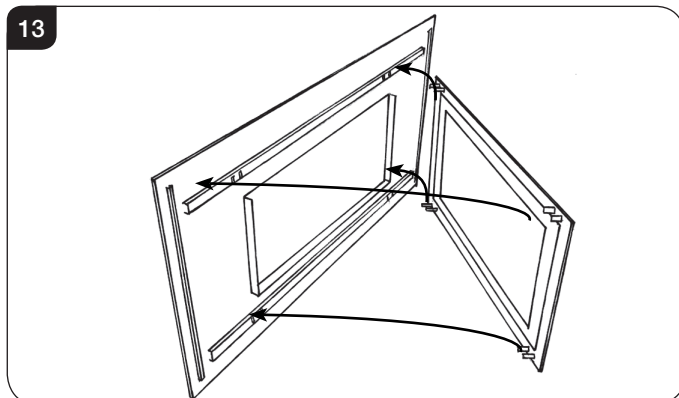

All models

7.5 Using the hexagon key provided release the window locks at the top of the glass door, see Diagram 14.

7.6 The locks move from shut to open towards the outer edges of the glass door, see Diagram 14.

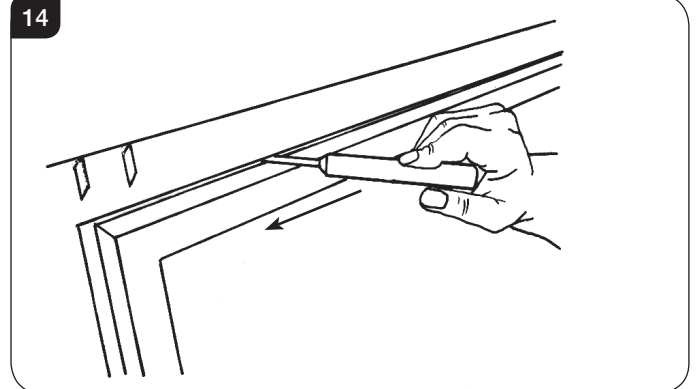

7.7 Support the door and let it fall gently forward.

7.8 Open it down to its stop position.

7.9 **When closing the door ensure the door catches are fully engaged.**



UNDER NO CIRCUMSTANCES SHOULD THE APPLIANCE BE USED WITHOUT THE CATCHES HOLDING THE DOOR IN PLACE.

8. Arrangement of the fuel bed

Advice on handling and disposal of fire ceramics



The fuel effect of the log version of this appliance is made from Refractory Ceramic Fibre (RCF), a material which is commonly used for this application.

Protective clothing is not required when handling these articles, but we recommend you follow normal hygiene rules of not smoking, eating or drinking in the work area and always wash your hands before eating or drinking.

To ensure that the release of RCF fibres are kept to a minimum, during installation and servicing a HEPA filtered vacuum is recommended to remove any dust accumulated in and around the appliance before and after working on it. When servicing the appliance it is recommended that the replaced items are not broken up, but are sealed within heavy duty polythene bags and labelled as RCF waste.

RCF waste is classed as stable, non-reactive hazardous waste and may be disposed of at a licensed landfill site.

Excessive exposure to these materials may cause temporary irritation to eyes, skin and respiratory tract; wash hands thoroughly after handling the material.

User Instructions

- 8.1 **White Stone and Glass Fuel Effects:** To replace the white stone effect chippings or glass granules, make sure they are flattened so they are level with the rim of the tray.
- 8.2 **Vermiculite for Log Layout:** Use the entire bag of supplied Vermiculite.

TAKE CARE NOT TO SPILL STONE EFFECT CHIPPINGS, GLASS GRANULES OR VERMICULITE INTO THE PILOT AREA. ONLY USE THE FUEL EFFECT SUPPLIED BY GAZCO IN THIS APPLIANCE.

9. Log Layout

LOGS MUST BE POSITIONED ACCORDING TO THE FOLLOWING INSTRUCTIONS TO GIVE THE CORRECT FLAME EFFECT

Layout for Studio 1

- 9.1 Use all the vermiculite to fill the burner tray and spread evenly across the whole burner.

- 9.2 Rest the ceramic bark against the front face of the pilot shield, see Diagram 15.

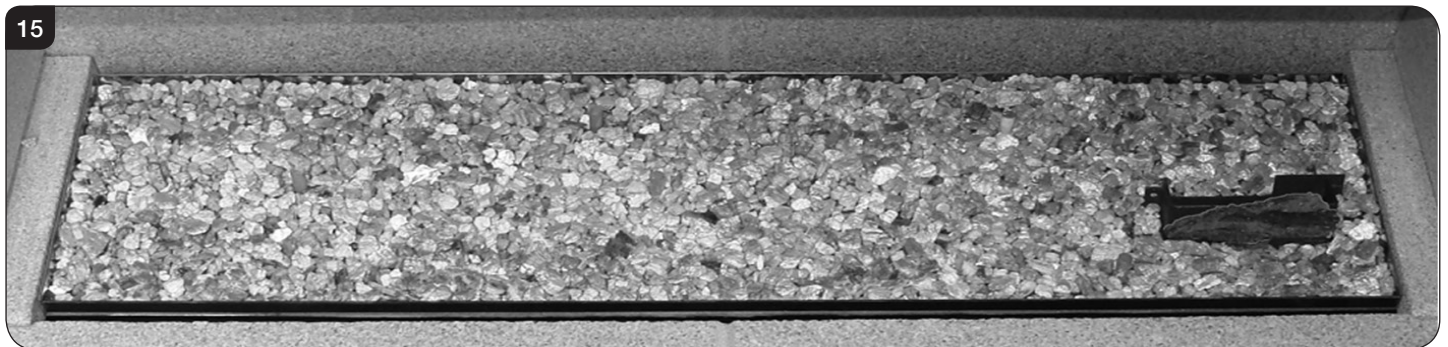

All logs can be identified by a letter (A - H) on their underside. The first three logs, A, B and C, also have holes to locate each onto a burner stud.

- 9.3 Working from left to right place logs A, B and C onto their studs as illustrated in Diagram 16.

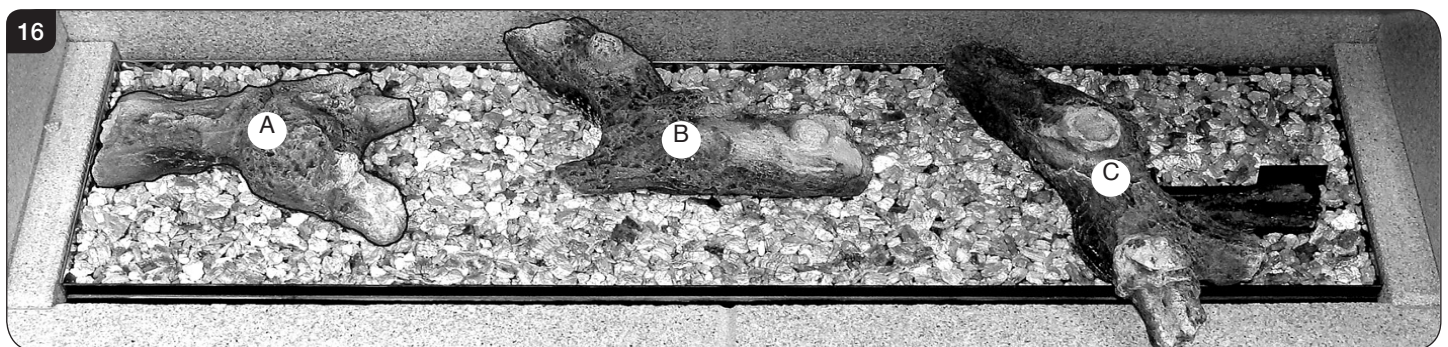
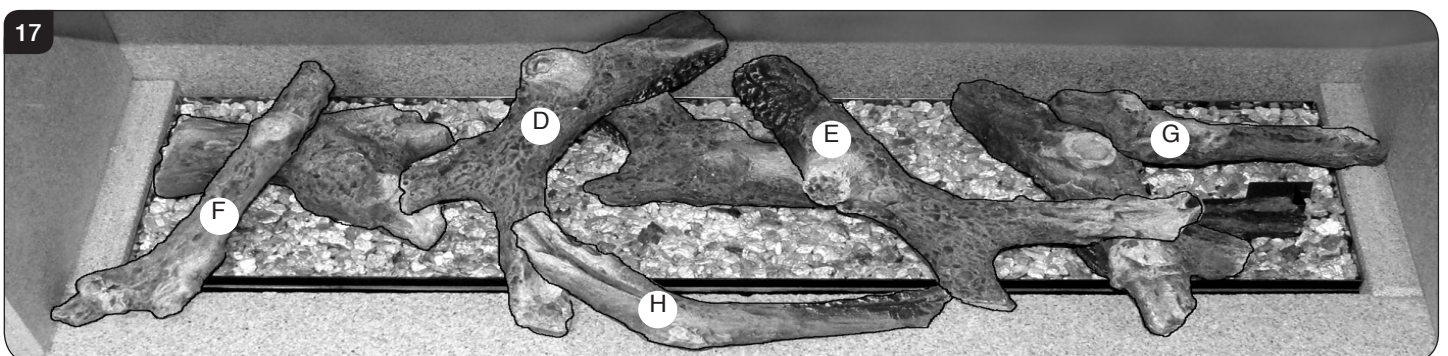

Diagram 17 shows the layout of logs D to H.

- 9.4 Log D has a recess on the underside to fit onto the stud of Log B at the back left. The small branch of the log rests on Log A.

- 9.5 A recess in the back of Log E fits the stud on Log B and its long branch rests snugly behind a wood knot of Log C.



User Instructions

- 9.6 Log F fits centrally onto Log A with its front edge resting on the front panel.
- 9.7 Log G is centrally positioned around the moulded wood knot of Log C and rests against the right side panel crossing the pilot shield beneath.
- 9.8 The small branch underneath Log H rests on the front panel and overlaps Log D just touching Log E.

- 9.9 Separate the Embaglow material into smaller pieces and pull into shape to create a fine layer.
- 9.10 Place the pieces of Embaglow between the logs in the highlighted areas shown in Diagram 18. Ensure the material is placed loosely between the logs to create a random glow.



Layout for Studio 2

- 9.11 Preparation with vermiculite and the ceramic bark pilot shield is the same as for Studio 1, see 9.1 & 9.2.

All logs can be identified by the letters (A - J) on their underside. The first four logs, I, A, B and C also have holes to locate each onto a burner stud.

- 9.12 Place logs I, A, B and C onto their studs as illustrated in Diagram 19.

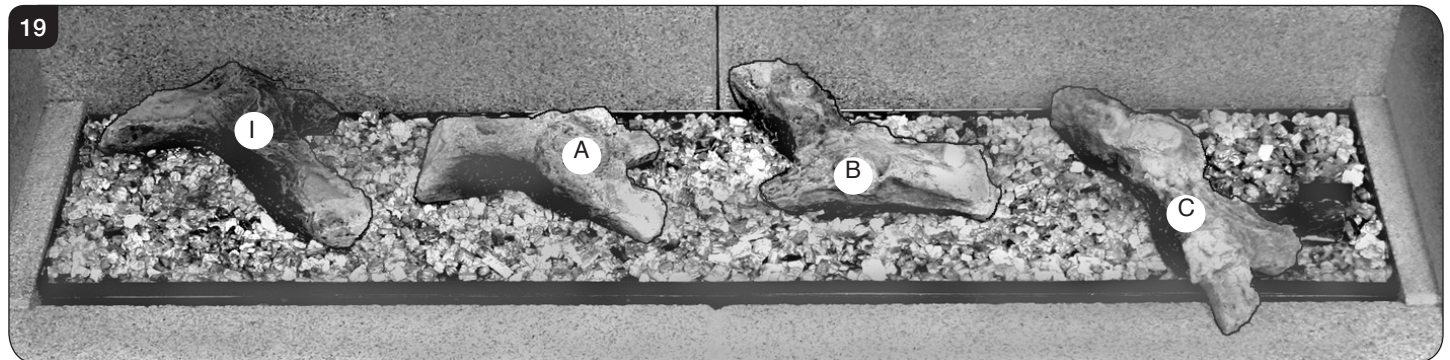
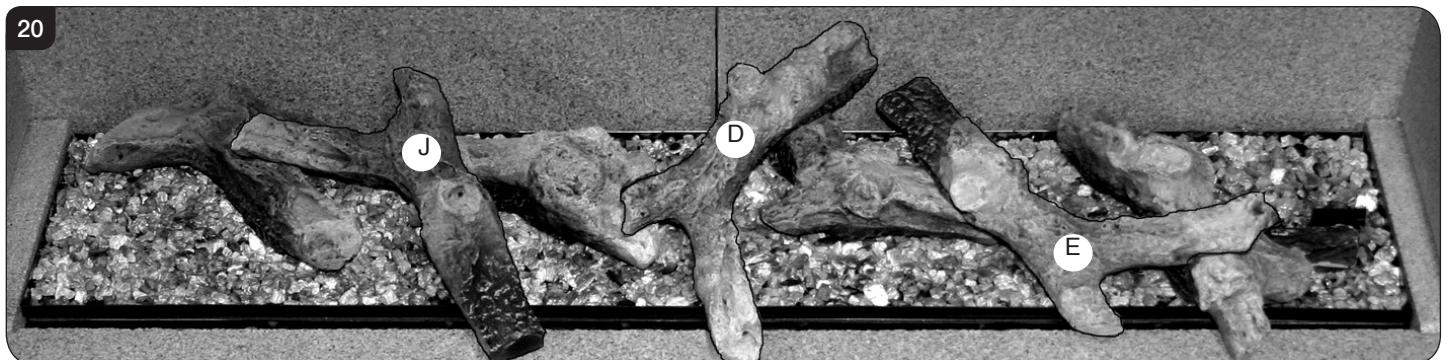

Diagram 20 shows the layout of logs D, E and J.

- 9.13 Log D has a recess on the underside to fit onto the stud of Log B at the back left. The small branch of the log rests on Log A.

- 9.14 A recess in the back of Log E fits the stud on Log B and its long branch rests snugly behind a wood knot of Log C.



User Instructions

9.15 The underside of log J has a moulded 'stop'. This rests about 12mm in from the left edge of Log A. The left branch of Log J also rests in the recess in Log I, see Diagram 20.

Diagram 21 shows the layout of the last four logs, F, G and two of log H:

9.16 Log F fits centrally onto Log I with its front edge resting on the front panel.

9.17 Log G is centrally positioned around the moulded wood knot of Log C and rests against the right side panel crossing the pilot shield beneath.

9.18 The first Log H rests on the front panel, overlapping Log D and touching Log E.

9.19 The second Log H rests anywhere on the front panel between F and J. **DO NOT LET THIS LOG OVERLAP THE BURNER.**

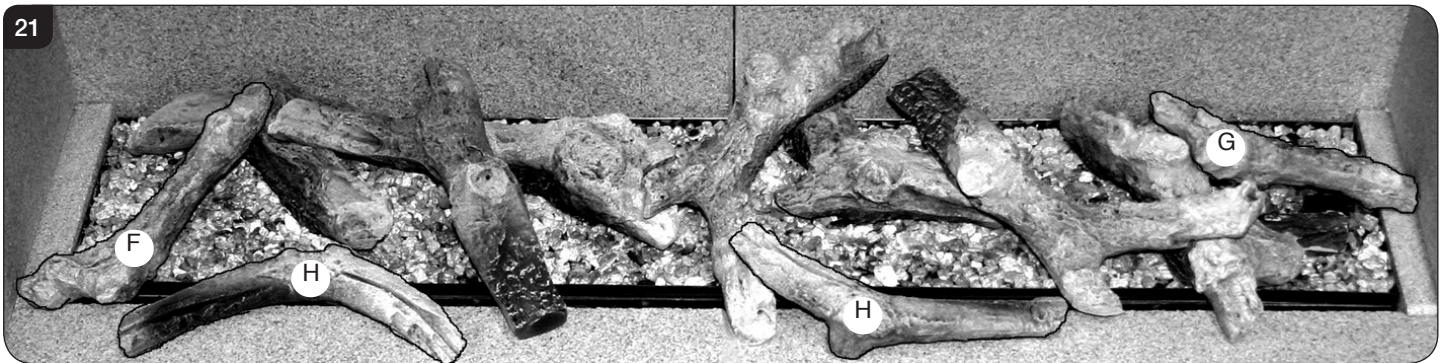

9.20 Separate the Embaglow material into smaller pieces and pull into shape to create a fine layer.

9.21 Place the pieces of Embaglow between the logs in the highlighted areas shown in Diagram 22. Ensure the material is placed loosely between the logs to create a random glow.



Layout for Studio 3

9.22 Use all the vermiculite to fill the burner tray and spread evenly across the whole burner.

9.23 Rest the ceramic bark against the front face of the pilot shield, see Diagram 23.

All logs can be identified by the letters (A - K) on their underside. The first five logs, K, I, A, B and C also have holes to locate each onto a burner stud.

9.24 Place logs K, I, A, B and C onto their stud, see Diagram 23.

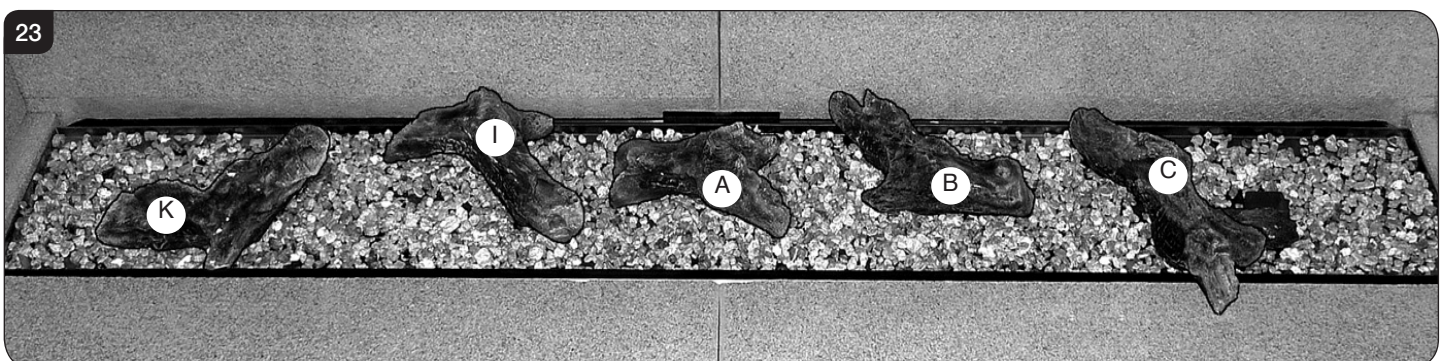

User Instructions

Diagram 24 shows the layout of logs F, E, J, D, E and C. Working from left to right:

9.25 Log F rests in an indent in Log K with the letter on the underside facing down and a top stud lying towards the back left of the burner tray.

9.26 Log E fits onto the stud on the back right of Log K. The right-hand branch rests against Log I (see Diagram 24).

9.27 The underside of log J has a moulded 'stop'. This rests about 12mm in from the left edge of Log A. The left branch of Log J rests in a recess in Log I, see Diagram 24.

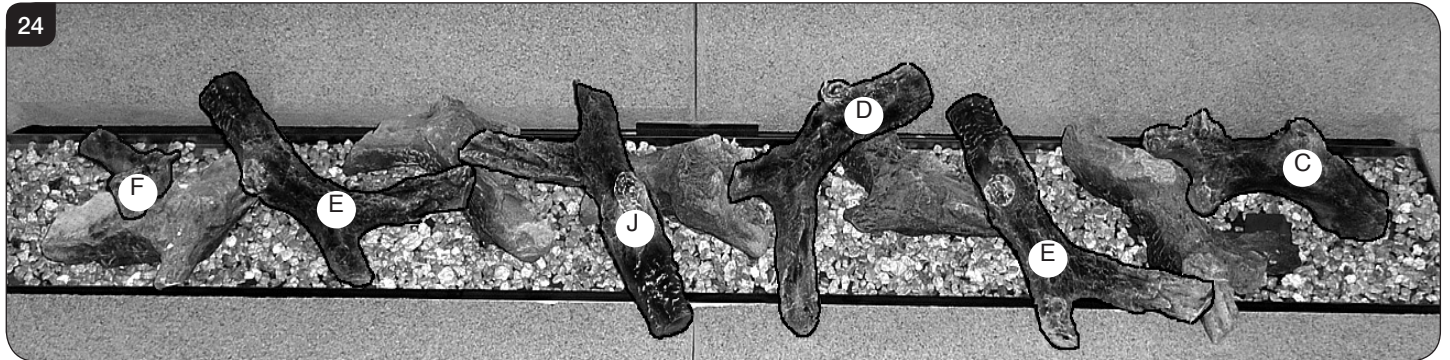

9.28 Log D has a recess on the underside to fit onto the stud of Log B at the back left. The small branch of the log rests on Log A.

9.29 A recess in the back of Log E fits the stud on Log B and its long branch rests snugly behind a wood knot of Log C.

9.30 The fork of the branches of Log C rest around the wood knot of Log C beneath and cross the pilot shield below.

Diagram 25 shows the layout of logs D, F, H, G, H. Working from left to right:

9.31 Log D's recess fits the stud at the back left of Log F. The branch must overlap the side and front edge panels, see Diagram 25.

9.32 Log F rests on a little notch on the lower branch of Log E and overlaps the front edge panel, see Diagram 25.

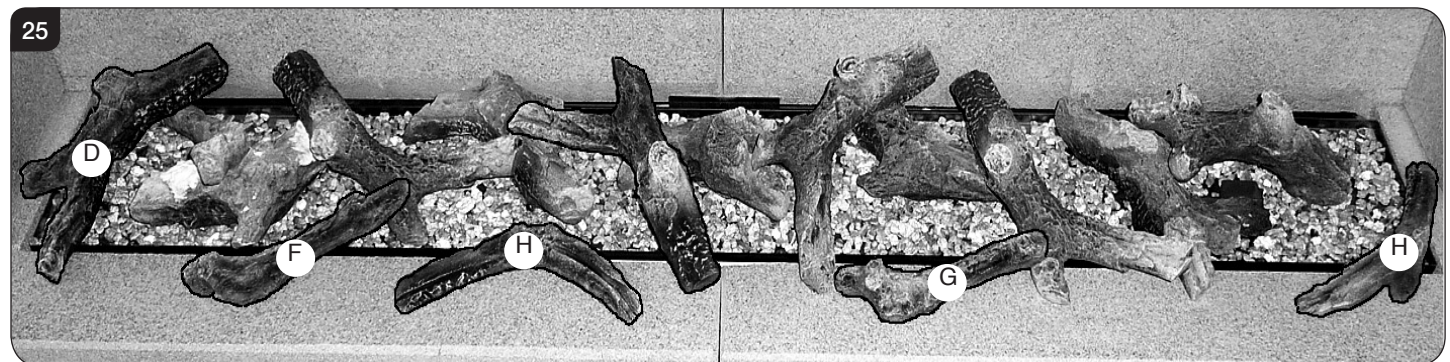

9.33 Log H rests anywhere on the front panel between F and J.

9.34 Log G rests against the lower branch of Log E as shown in Diagram 25.

9.35 The second Log H arches across the side and front panels. **DO NOT LET THIS LOG SIT ON THE BURNER TRAY.**

9.36 Separate the Embaglow material into smaller pieces and pull into shape to create a fine layer.

9.37 Place the pieces of Embaglow between the logs in the highlighted areas shown in Diagram 26. Ensure the material is placed loosely between the logs to create a random glow.

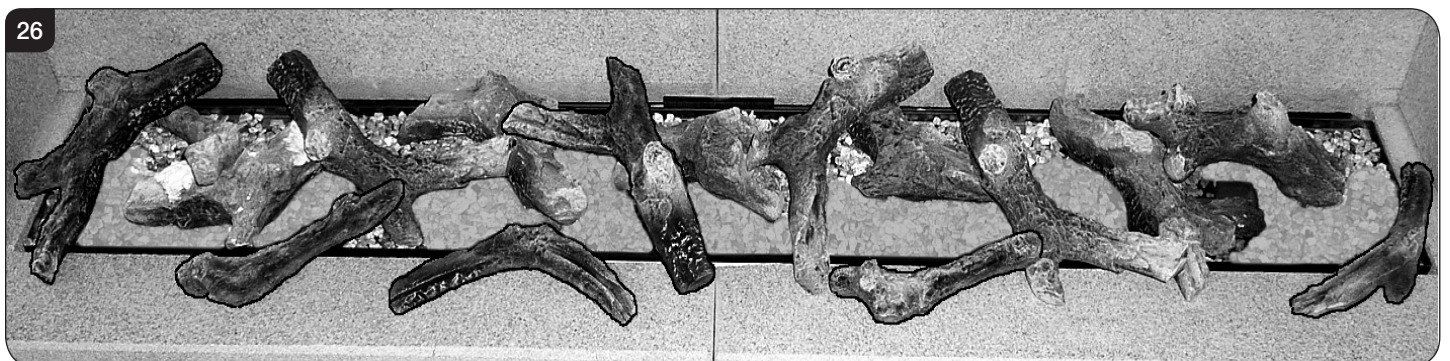

10. Flame Failure Device

- 10.1 This is a safety feature incorporated on this appliance which automatically switches off the gas supply if the pilot goes out and fails to heat the thermocouple.

IF THIS OCCURS DO NOT ATTEMPT TO RELIGHT THE APPLIANCE FOR 3 MINUTES.

11. Running In

- 11.1 During initial use of a new GAZCO appliance a strong odour will be encountered as various surface coatings become hot for the first time. Although these odours are harmless it is recommended that the appliance is operated on maximum for 4 to 8 hours in order to fully burn off these coatings. After this period the odours should then disappear.

If the odours persists, please contact your installer for advice.

- 11.2 During the first few hours of burning there may be discolouration of the flames. This will also disappear after a short period of use.

12. Servicing

- 12.1 The appliance must be serviced every 12 months by a qualified Gas Engineer. In all correspondence always quote the Model number and the Serial number which may be found on the data badge.

13. Ventilation

- 13.1 Any purpose provided ventilation should be checked periodically to ensure that it is free from obstruction.

14. Installation Details

- 14.1 The installer should have completed the commissioning sheet at the front of this book. This records the essential installation details of the appliance. In all correspondence always quote the Model number and Serial number.

15. Hot Surfaces

- 15.1 Parts of this appliance become hot during normal use.
- 15.2 Regard all parts of the appliance as a working surface.
- 15.3 Provide a suitable fire guard to protect young children and the infirm.

16. Appliance will not light

If you cannot light the Studio:

- 16.1 Check and change the batteries in the remote handset.
- 16.2 Check and change the wall switch batteries (see Section 6).
- 16.3 Consult your Gazco retailer or installer if the Studio still does not light.

Installation Instructions

Technical Specification

Covering the following models:

STUDIO 1	STUDIO 2	STUDIO 3
123-309	123-162	123-032
123-558	123-676	123-514

Stone Chippings Versions

Model	Gas CAT.	Gas Type	Working Pressure	Aeration	Injector	Gas Rate m ³ /h	Input kW (Gross)		Country
							High	Low	
Studio 1 123-309	I ₂ H	Natural (G20)	20mbar	16 x 23	400	0.600	6.3	3.0	GB, IE
Studio 1 123-558	I ₃ P	Propane (G31)	37mbar	14 x 16 (1)	185	0.230	6.1	3.0	GB, IE
				16 x 23 (1)					
Studio 2 123-162	I ₂ H	Natural (G20)	20mbar	14 x 16	600	0.800	8.4	4.3	GB, IE
Studio 2 123-676	I ₃ P	Propane (G31)	37mbar	14 x 16 (1)	225	0.275	7.3	4.0	GB, IE
				16 x 23 (1)					
Studio 3 123-032	I ₂ H	Natural (G20)	20mbar	LH 6 x 6	180	0.858	9.0	5.2	GB, IE
				RH 6 x 6					
Studio 3 123-514	I ₃ P	Propane (G31)	37mbar	LH 10 x 16 / 16 x 23	120	0.339	9.0	5.2	GB, IE
				RH 10 x 16 / 16 x 23					
Efficiency Class 2 - 81% / NO_x Class 4									
Flue Outlet Size Ø 150mm									
Flue Inlet Size Ø 100mm									
Gas Inlet Connection Size Ø 8mm									

RESTRICTOR REQUIREMENT

VERTICAL & HORIZONTAL FLUE			TOP EXIT - VERTICAL ONLY INCLUDING OFFSET	
STUDIO 1 BF			STUDIO 1 BF	
Vertical Flue Height	Horizontal Length	Restrictor Size	Vertical Flue Height	Restrictor Size
200mm - 500mm	Up to 500mm	No restrictor	3000 - 4990mm	Ø 52mm
500mm - 1000mm	Up to 1000mm	No restrictor	5000mm - 10,000mm	Ø 47mm
1000mm - 1490mm	Up to 1000mm	70mm Ø		
1500mm - 1990mm	Up to 5000mm	70mm Ø		
2000mm - 3000mm	Up to 5000mm	60mm Ø		
STUDIO 2 BF			STUDIO 2 BF	
700mm - 1490mm	Up to 1000mm	No restrictor	3000 - 4990mm	Ø 60mm
1500mm - 2490mm	Up to 5000mm	No restrictor	5000mm - 10,000mm	Ø 52mm
2500mm - 3000mm	Up to 5000mm	75mm Ø		
STUDIO 3 BF			STUDIO 3 BF	
1000mm - 1490mm	Up to 500mm	No restrictor	3000 - 4990mm	Ø 70mm
1500mm - 1990mm	Up to 1000mm	No restrictor	5000mm - 10,000mm	Ø 60mm
2500mm - 3000mm	Up to 5000mm	No restrictor		

Installation Instructions

Technical Specification

Covering the following models:

STUDIO 1	STUDIO 2	STUDIO 3
123-180	123-228	123-393
123-621	123-713	123-446
123-018	123-252	123-047
123-437	123-682	123-649

Log Versions

Model	Gas CAT.	Gas Type	Working Pressure	Aeration	Injector	Gas Rate m ³ /h	Input kW (Gross)		Country
							High	Low	
Studio 1	I ₂ H	Natural (G20)	20mbar	8 x 15	400	0.610	6.4	4.0	GB, IE
Studio 1	I ₃ P	Propane (G31)	37mbar	10 x 16	185	0.237	6.3	4.0	GB, IE
				16 x 23					
Studio 2	I ₂ H	Natural (G20)	20mbar	10 x 16	600	0.800	8.6	4.4	GB, IE
Studio 2	I ₃ P	Propane (G31)	37mbar	5 x 16	150	0.301	8.0	4.4	GB, IE
				16 x 23					
Studio 3 12	I ₂ H	Natural (G20)	20mbar	LH 8 x 15 RH 8 x 15	375	0.962	10.1	5.2	GB, IE
Studio 3 12	I ₃ P	Propane (G31)	37mbar	LH 14 x 15 16 x 23 RH 14 x 15 16 x 23	125	0.380	10.1	5.2	GB, IE
Efficiency Class 2 - 81% / NO_x Class 4									
Flue Outlet Size Ø 150mm									
Flue Inlet Size Ø 100mm									
Gas Inlet Connection Size Ø 8mm									

RESTRICTOR REQUIREMENT

VERTICAL & HORIZONTAL FLUE			TOP EXIT - VERTICAL ONLY INCLUDING OFFSET	
STUDIO 1 BF			STUDIO 1 BF	
Vertical Flue Height	Horizontal Length	Restrictor Size	Vertical Flue Height	Restrictor Size
200mm - 500mm	Up to 500mm	No restrictor	3000 - 4990mm	Ø 52mm
500mm - 1000mm	Up to 1000mm	No restrictor	5000mm - 10,000mm	Ø 47mm
1000mm - 1490mm	Up to 1000mm	70mm Ø		
1500mm - 1990mm	Up to 5000mm	70mm Ø		
2000mm - 3000mm	Up to 5000mm	60mm Ø		
STUDIO 2 BF			STUDIO 2 BF	
700mm - 1490mm	Up to 1000mm	No restrictor	3000 - 4990mm	Ø 60mm
1500mm - 2490mm	Up to 5000mm	No restrictor	5000mm - 10,000mm	Ø 52mm
2500mm - 3000mm	Up to 5000mm	75mm Ø		
STUDIO 3 BF			STUDIO 3 BF	
1000mm - 1490mm	Up to 500mm	No restrictor	3000 - 4990mm	Ø 70mm
1500mm - 1990mm	Up to 1000mm	No restrictor	5000mm - 10,000mm	Ø 60mm
2500mm - 3000mm	Up to 5000mm	No restrictor		

Installation Instructions

Technical Specification

This appliance has been certified for use in countries other than those stated. To install this appliance in these countries, it is essential to obtain the translated instructions and in some cases the appliance will require modification. Contact Gazco for further information.

PACKING CHECKLIST

Qty Description	Fixing Kit containing:
Stone Chippings Effect Version: 1 x White Stone Chippings	1 x Instruction Manual 4 x Wood Screws 4 x Wall Plugs 1 x Handset
Log Version: 1 x Log Set 1 x Vermiculite 1 x Bag Embaglow material	2 x AA 1.5 alkaline batteries 3 x Size C batteries 1 x Wall box 1 x Wall plate / touch pad 1 x Battery holder 1 x Foam seal

745 - Studio 1BF
945 - Studio 2BF
1335 - Studio 3BF

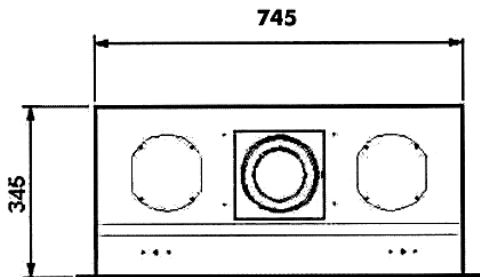

820 - Studio 1BF
1020 - Studio 2BF
1410 - Studio 2BF

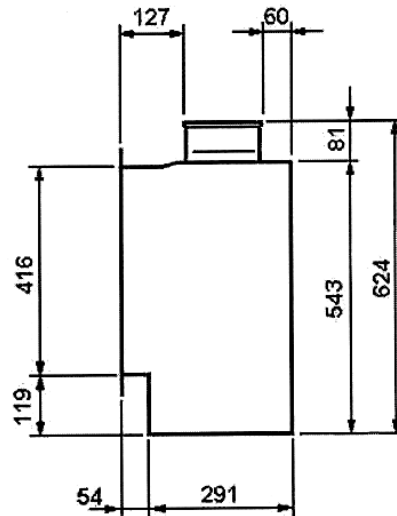
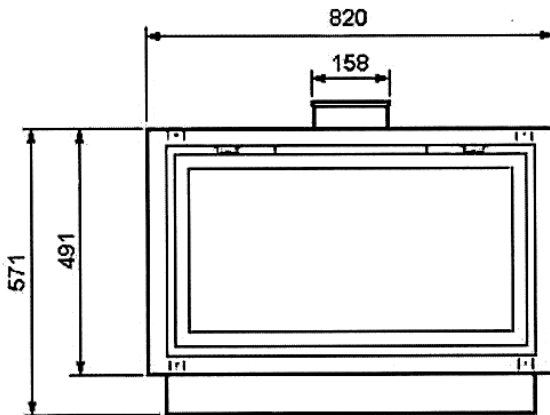

Installation Instructions

Technical Specification

Steel Fronts					
Model	A	B	C	D	E
Studio 1	1264	528	846	320	27
Studio 2	1500	528	846	320	27
Studio 3	1990	528	1236	320	27

Glass Fronts					
Model	A	B	C	D	E
Studio 1	1264	528	650	324	29
Studio 2	1500	528	852	324	29
Studio 3	1990	528	1240	324	29

Verve Fronts					
Model	A	B	C	D	E
Studio 1	1264	528	650	324	53
Studio 2	1500	528	850	324	53
Studio 3	1990	528	1240	324	53

Profil Fronts					
Model	A	B	C	D	E
Studio 1	836	510	740	414	12.5
Studio 2	1036	510	940	414	12.5
Studio 3	1426	510	1330	414	12.5

Bauhaus Fronts					
Model	A	B	C	D	E
Studio 1	850	524	740	414	28
Studio 2	1050	524	940	414	28
Studio 3	1440	524	1330	414	28

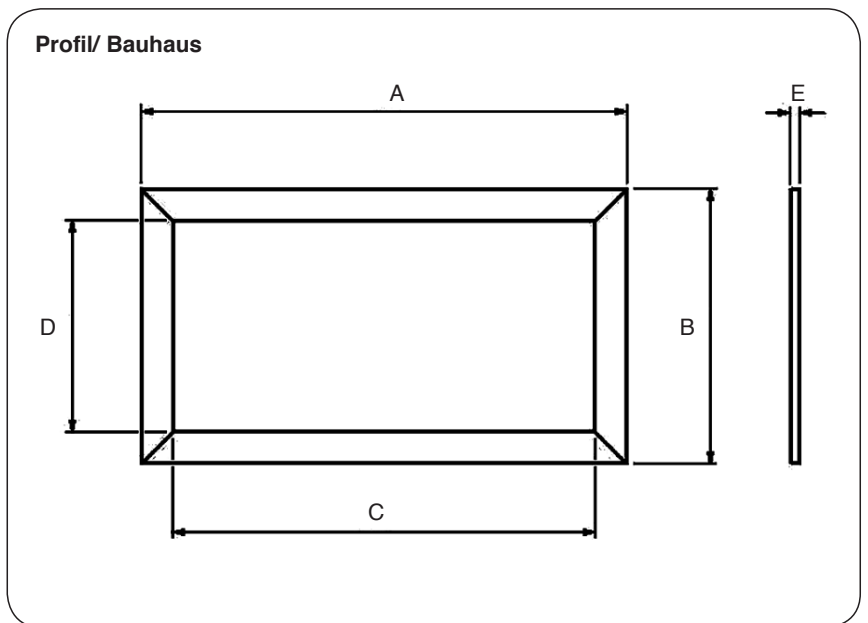
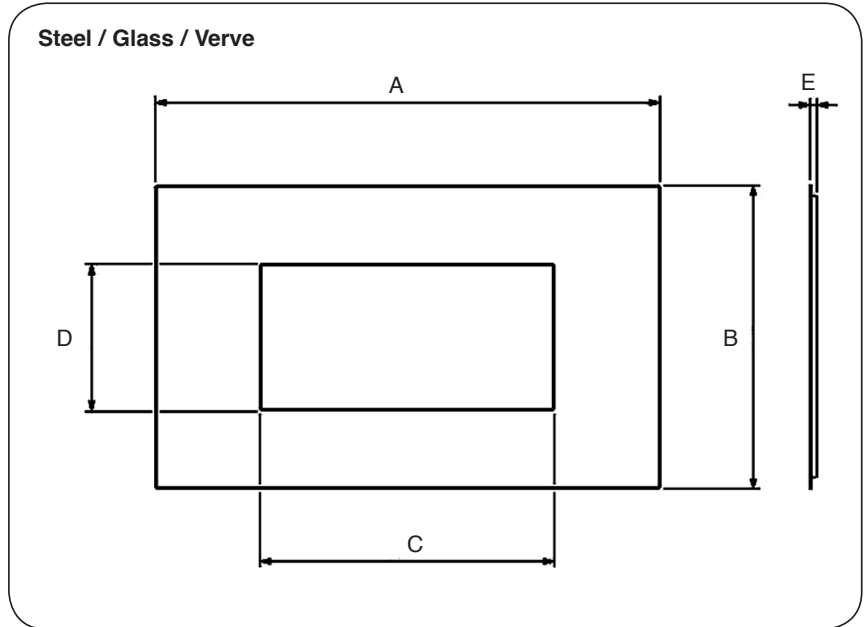

Installation Instructions

Site Requirements

1. Flue & Chimney Requirements

Note: This appliance must only be installed with the flue supplied.

You must adhere to the following:

- 1.1 The flue must be sited in accordance with BS5440: Part 1 (latest edition), see Diagram 1.
- 1.2 Fit a guard to protect people from any terminal less than 2 metres above any access such as level ground, a balcony or above a flat roof.
- 1.3 All vertical and horizontal flues must be securely fixed and fire precautions followed in accordance with local and national codes of practice.
- 1.4 A restrictor may be required, see Technical Specifications on page 16 & 17.
- 1.5 Two types of flue terminals are available, horizontal and vertical.

- 1.6 To measure for a horizontal terminal decide on the terminal position.
- 1.7 Measure the height from the top of the appliance to the centre of the required outlet.
- 1.8 For minimum and maximum flue dimensions see Diagrams 1A/1B.
- 1.9 Allow enough room either above or to the side of the appliance to assemble the flue on top
- 1.10 Assemble a horizontal flue in the following order:
 - Vertical section
 - 90° elbow
 - Horizontal plus terminal
- 1.11 Support the opening of a masonry installation with a lintel.
- 1.12 Only the horizontal terminal section can be reduced in size.

1 UK Dimensions

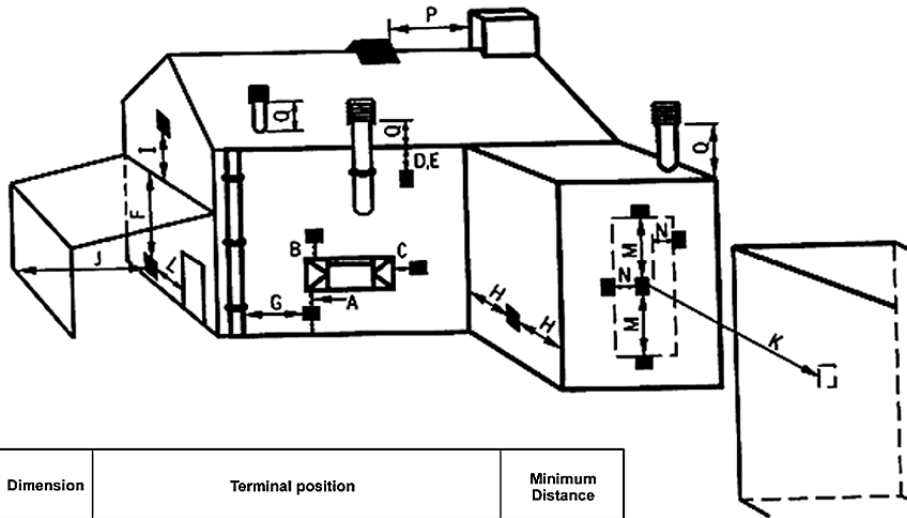

Dimension	Terminal position	Minimum Distance
A*	Directly below an opening, air brick, opening windows, etc.	600mm
B*	Above an opening, air brick opening windows, etc.	300mm
C*	Horizontally to an opening, air brick opening windows etc.	400mm
D	Below gutters, soil pipes or drain pipe	300mm
E	Below eaves	300mm
F	Below balconies or car port roof	600mm
G	From a vertical drain pipe or soil pipe	300mm
H	From an internal or external corner	600mm
I	Above group roof or balcony level	300mm
J	From a surface facing the terminal (also see 6.1.2)	600mm
K	From a terminal facing the terminal	600mm
L	From an opening in the car port (e.g. door, window) into the dwelling	1200mm
M	Vertically from a terminal on the same wall	1500mm
N	Horizontally from a terminal on the same wall	300mm
O	From the wall on which the terminal is mounted	N/A
P	From a vertical structure on the roof	600mm
Q	Above intersection with roof	300mm

* In addition, the terminal should not be nearer than 300mm to an opening in the building fabric formed for the purpose of accommodating a built-in element such as a window frame

Installation Instructions

Site Requirements

2. Flue Options

STUDIO 1 BF

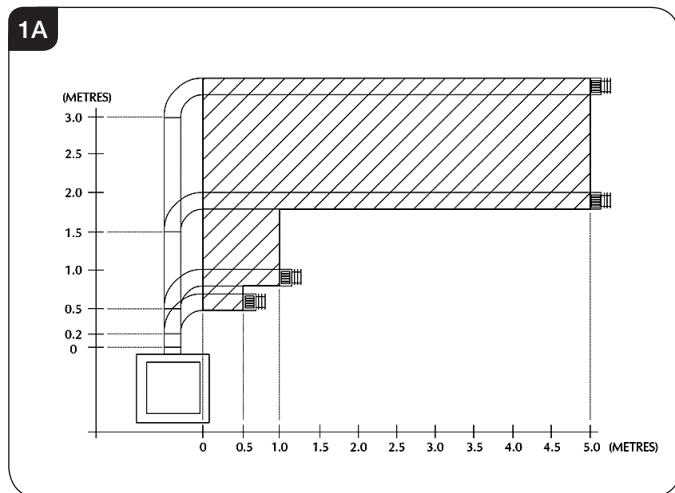

STUDIO 2 BF

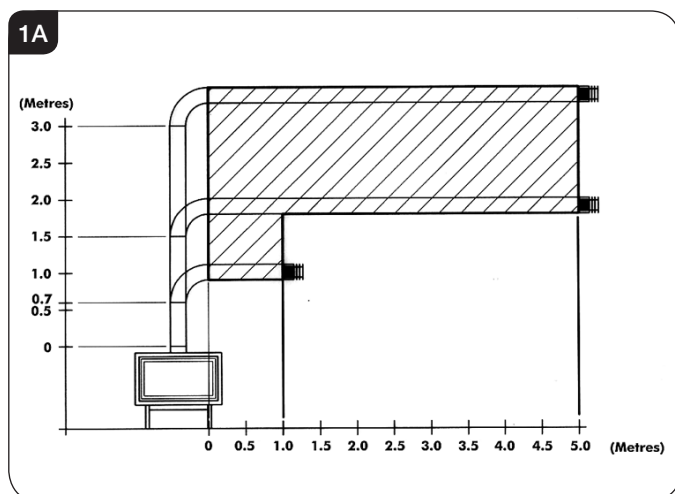

STUDIO 3 BF

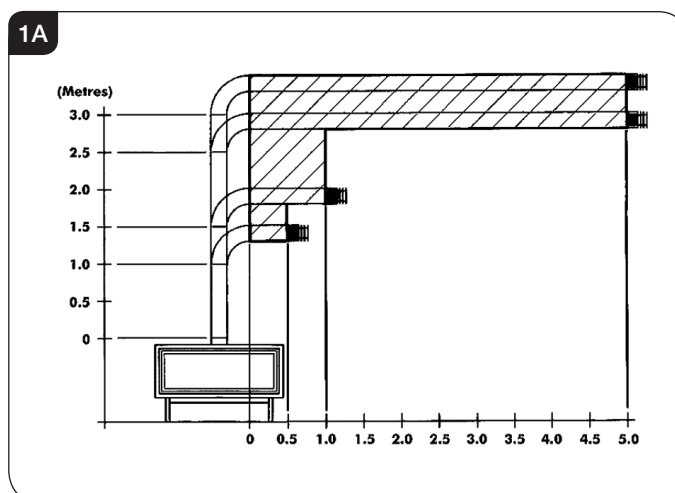

Start of bend to centre line of horizontal flue 170mm.
Centre line of vertical flue to end of bend 220mm.

2A. Top Flue Up and Out Kit

2.1 Vertical from the top of the appliance then horizontally out, see Diagram 1A. The basic kit comprises:

STUDIO 1 BF (8534/8534AN)

- 1 x 200mm vertical length
- 1 x 500mm terminal length (cut to length on site)
- 1 x 90° elbow
- 1 x wall plate
- 1 x 70mm restrictor
- 1 x 60mm restrictor

STUDIO 2 BF (8509/8509AN)

- 1 x 200mm vertical length
- 1 x 500mm vertical length
- 1 x 500mm terminal length (cut to length on site)
- 1 x 90° elbow
- 1 x wall plate
- 1 x 75mm restrictor

The kit may be used on its own. (Note – STUDIO 1 BF with a 200mm rise only the 500mm terminal length can be used). Extra lengths may be added to the vertical and horizontal from the list below.

STUDIO 3 BF (8567/8567AN)

- 1 x 1000mm vertical length
- 1 x 500mm terminal length (cut to length on site)
- 1 x 90° elbow
- 1 x wall plate

The kit may be used on its own. (Note – STUDIO 1 BF with a 200mm rise only the 500mm terminal length can be used). Extra lengths may be added to the vertical and horizontal from the list below.

Installation Instructions

Site Requirements

2B. Top Flue Up and Out with Additional Bend

2.2 An additional bend may be used on the horizontal section (either 45° or 90°), but the overall horizontal flue run will be reduced, see Diagram 1B.

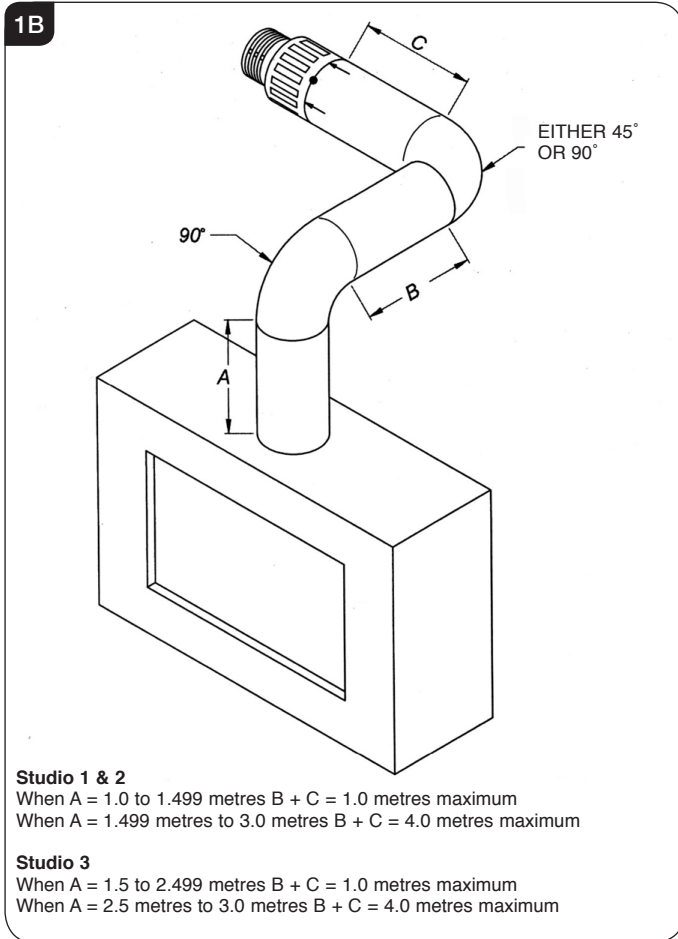

2C Top Flue Vertical Kit (8524/8524AN)

2.3 Vertical from the top of the appliance, see Diagram 1C. A minimum vertical rise 3m (9'10") to a maximum 10m (32'10"). The basic kit comprises:
2 x 1m lengths
1 x 1m terminal length
1 x 52mm restrictor
1 x 47mm restrictor
1 x 60mm restrictor
1 x 70mm restrictor
Extra lengths may be added from the list below.

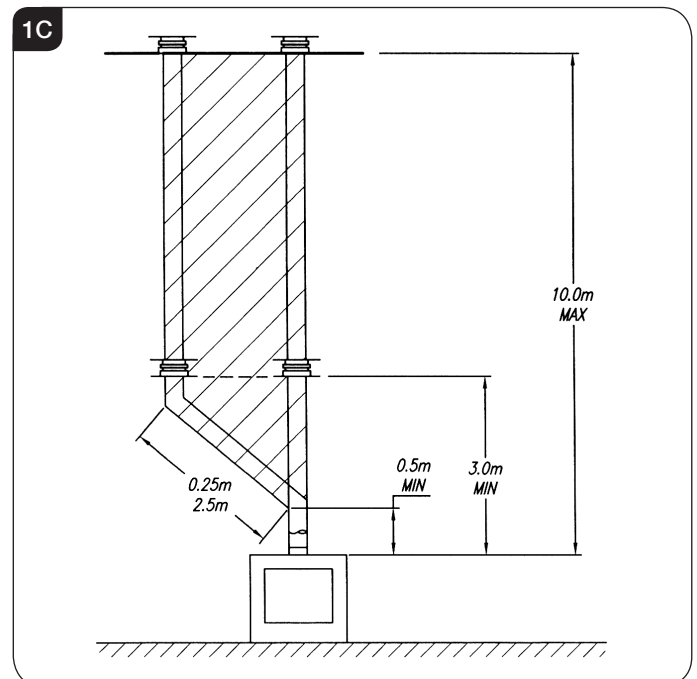

2D Top Flue Vertical Offset Kit (8530/8530AN)

2.4 Used with kit 8524. A minimum rise of 500mm (19¹/₂) is required to the first bend, see Diagram 1C.

Installation Instructions

Site Requirements

3. Optional Extra Flue Lengths and Bends

All flue components are 150mm diameter (6")

NOMINAL LENGTH	ACTUAL LENGTH	STAINLESS FINISH	ANTHRACITE FINISH
200mm	140mm	8527	8527AN
500mm	440mm	8528	8528AN
1000mm	940mm	8529	8529AN
40° Bend	N/A	8507	8507AN
90° Bend	N/A	8508	8508AN

NOTE - Carefully consider:

- a) Terminal positions
- b) Flue supports
- c) Weatherproofing
- d) Fire precautions

For all the above options, you must conform to local and national codes of practice.

4. Gas Supply

THIS APPLIANCE IS INTENDED FOR USE ON A GAS INSTALLATION WITH A GOVERNED METER.

- 4.1 Before installation, ensure that the local distribution conditions (identification of the type of gas and pressure) and the adjustment of the appliance are compatible.
- 4.2 Ensure the gas supply delivers the required amount of gas and is in accordance with the rules in force.
- 4.3 You can use soft copper tubing on the installation and soft soldered joints outside the appliance and below the firebed.
- 4.4 A factory fitted isolation device is part of the inlet connection; no further isolation device is required.
- 4.5 All supply gas pipes must be purged of any debris that may have entered prior to connection to the appliance.
- 4.6 The gas supply enters through the silicone panel located on the LEFT-HAND side of the outer box. Slit with a sharp knife before passing the supply pipe through
- 4.7 The gas supply must be installed in a way that does not restrict the removal of the appliance for servicing and inspection.

5. Ventilation

- 5.1 This appliance requires no additional ventilation.

6. Appliance Location

- 6.1 Please note this appliance has been primarily designed for studwork applications. However, there are circumstances where one of the kits could be used on a block or brickwork fireplace using different methods and materials for the final effect.

The three methods of studwork installation are:

**Frame (see Installation Instructions, Section 4).
Edge (see Installation Instructions, Section 5).
Cool Wall (see Installation Instructions, Section 6).**

- 6.2 This appliance must stand on a non-combustible platform that is at least 12mm thick.

NOTE: If you intend to construct the fascia of the fireplace opening from natural materials it is recommended you cut this into three or more sections to prevent cracking. Resin-based materials may not be suitable. This appliance is an effective heat producer and attention must be paid to the construction and finish of the fireplace.

- 6.3 A combustible shelf must be:
 - Maximum 150mm in depth.
 - Minimum 400mm high above the appliance.

A combustible side wall must be a minimum of 150mm from the appliance.

- 6.4 This appliance can be installed with an up and out flue (vertical wall - horizontal flue) or with a vertical flue with roof termination, see Site Requirements, Section 2, Flue Options.
- 6.5 This appliance is not suitable for installation onto a combustible wall. Remove all combustible material from the area shown, see Installation Instructions, Section 3.1.

Installation Instructions

1. Safety Precautions

- 1.1 For your own and other's safety, you must install this stove according to local and national codes of practice. Failure to install the stove correctly could lead to prosecution. **Read these instructions before installing and using this appliance.**
- 1.2 These instructions must be left intact with the user.
- 1.3 Do not attempt to burn rubbish on this appliance.
- 1.4 Keep all plastic bags away from young children.
- 1.5 Do not place any object on or near to the appliance and allow adequate clearance above the appliance.

IF THE APPLIANCE IS EXTINGUISHED OR GOES OUT IN USE, WAIT 3 MINUTES BEFORE ATTEMPTING TO RELIGHT THE APPLIANCE.



IMPORTANT: REFER TO DATA BADGE AND TECHNICAL SPECIFICATION AT THE FRONT OF THE MANUAL TO ENSURE THE APPLIANCE IS CORRECTLY ADJUSTED FOR THE GAS TYPE AND CATEGORY APPLICABLE IN THE COUNTRY OF USE.

FOR DETAILS OF CHANGING BETWEEN GAS TYPES REFER TO SERVICING, SECTION 16, REPLACING PARTS.

Unpacking

- 1.6 Remove the appliance from its packaging, and check that it is complete and undamaged.

Put the loose ceramic parts to one side so that they are not damaged during installation.

2. Installation of the Appliance

THERE IS AN OPTIONAL DUCT KIT, CODE No. 8572 WHICH CAN BE FITTED AT THE SAME TIME AS THE APPLIANCE INSTALLATION.

- 2.1 To open the glass door, use the hexagon key provided:
- 2.2 Release the window locks moving each from shut to open towards the outer edge of the glass door, see Diagram 1.

1

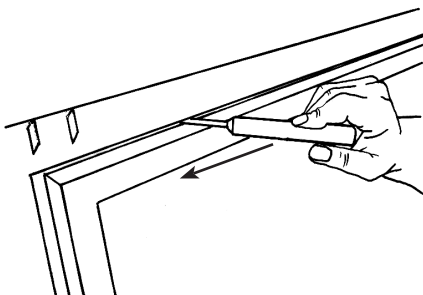

- 2.3 Remove the box from the appliance and store safely as it contains the remote control and fuel effects, etc.
- 2.4 Remove all the enamel liners where necessary. The rear panels on Studio 1 and 3 can remain in place, see Replacing Parts, Section 5.
- 2.5 Remove the Main Burner, see Replacing Parts, Section 7.
- 2.6 The gas supply enters the appliance through a silicon panel on the floor under the access panel, see Diagram 2.

2

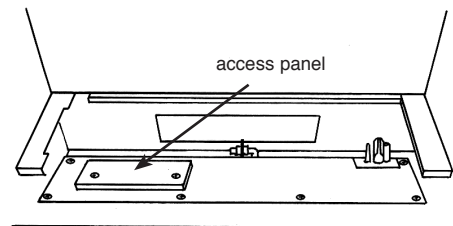

- 2.7 Slit with a sharp knife before bringing through the supply pipe, see Diagram 3.

3

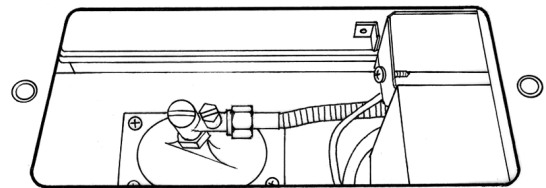

3. Studwork Installation

THERE ARE THREE TYPES OF INSTALLATION INTO STUDWORK DESCRIBED IN THE FOLLOWING PAGES:

- 1) **FOR STUDIO WITH EITHER THE STEEL, PROFIL OR BAUHAUS FRAME, SEE SECTION 4.**
- 2) **FOR AN INSTALLATION WHERE THE STUDIO SITS FLUSH TO THE FINISHED 'EDGE' OF THE WALL, SEE SECTION 5.**
- 3) **FOR A FURTHER 'EDGE' INSTALLATION PROVIDING A COOL WALL ABOVE THE APPLIANCE TO ALLOW CUSTOMERS TO HANG PICTURES ETC. SEE SECTION 6.**

3.1 DISTANCE TO COMBUSTIBLE MATERIAL

COMBUSTIBLE PARTS OF THE STUDWORK MUST BE KEPT BEYOND THE MINIMUM DIMENSIONS SHOWN IN DIAGRAM 4. EVEN IF THE FRAMEWORK IS PROTECTED BY NON-COMBUSTIBLE MATERIAL, YOU MUST MAINTAIN THESE DIMENSIONS, SEE DIAGRAM 4.

Installation Instructions

4

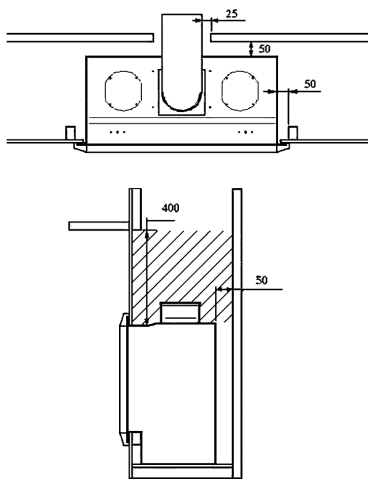

3.2 DISTANCE TO NON-COMBUSTIBLE OR COMBUSTIBLE MATERIAL ON STUDIO 3 ONLY

TO CREATE ENOUGH CLEARANCE FOR THE TOP VENTS TO OPEN ON THE STUDIO 3 IT IS IMPORTANT THAT NO PART OF THE STUDWORK, (COMBUSTIBLE OR NOT,) IS BUILT WITHIN 400MM OF THE TOP OF THE BOX.

3.3 DO NOT PACK THE VOID AROUND OR ABOVE THE APPLIANCE WITH INSULATION MATERIALS SUCH AS MINERAL WOOL.

3.4 THE VOID BUILT FOR THE CASSETTE MUST BE VENTILATED TO PREVENT A BUILD-UP OF HEAT. IF THE VOID IS SEALED, THEN YOU MUST FIT VENTS AT BOTH LOW AND HIGH LEVELS OF APPROXIMATELY 50CM² EACH. THESE VENTS MUST TAKE COLD AIR FROM THE ROOM AND RETURN WARM AIR BACK INTO THE ROOM.

4. Studwork Installation for Studio with frames

4.1 Build the studwork chimney breast and enclosures to the desired size to include the protected platform at the required height.

4.2 Line the aperture for the appliance with 12mm thick non-combustible material as shown, see Diagram 5.

5

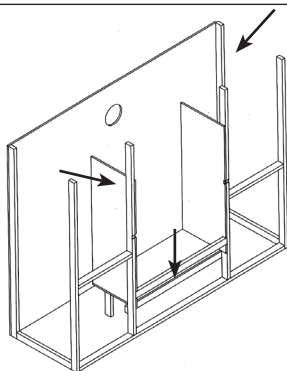

4.3 Ensure the clearances are maintained, see Diagram 4.

4.4 Site the appliance and decide on flue requirements.

4.5 Cut a hole for the flue exit (see Installation Instructions, Flue Assembly).

4.6 Provide gas and electric services into the cassette void on the left-hand side.

Because no combustible material can be used above the appliance, we provide a support bar:

4.7 **Mark out the position to fit the supplied top support bar into the studwork at the correct height. This bar needs to be recessed into the studwork, see Diagram 6.**

6

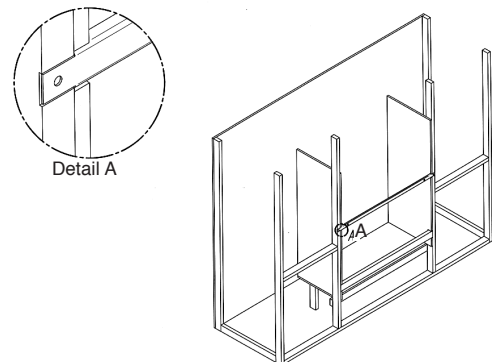

4.8 Fit the support bar into the studwork at the correct height, see Diagram 7.

7

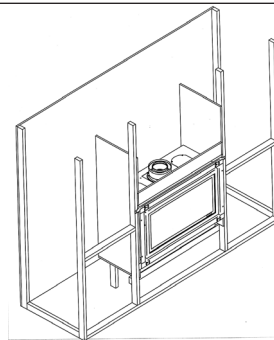

4.9 Attach the 4 x frame fixing brackets to the appliance, see Diagram 8.

8

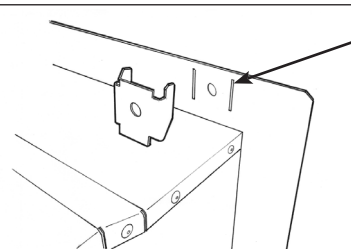

4.10 Fix foam seal to the rear of the outer flange of the appliance, see Diagram 9.

Installation Instructions

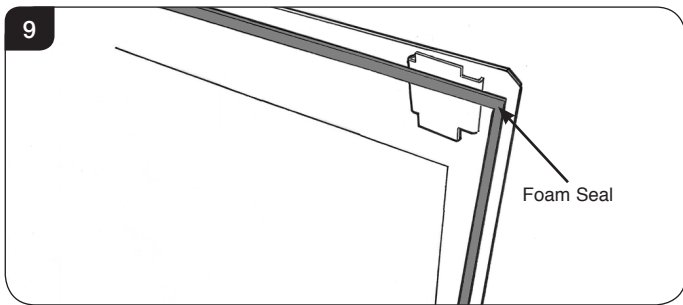

- 4.11 Position the appliance.
- 4.12 Fit non-combustible board to the studwork around the appliance. This should extend a minimum of 400mm above the appliance and at least 50mm to the sides of the appliance (from the outer box, not the flanges).
- 4.13 Apply plasterboard to the remainder of the studwork.
- 4.14 Secure the back of the appliance to the studwork using four screws through flange, bracket and support bar.
- 4.15 Apply a plaster finish to the front of the chimney breast.

Slips

Because of the high temperatures this appliance achieves, it is advisable to use marble slips or similar material between the appliance and the plasterboard.

Never use a one-piece slip as expansion (even cracking) can occur.

Note: If a slip is used, longer screws are needed to secure the appliance.

To finish this installation:

- 4.16 Connect the wall box and batteries following the instructions in Section 7 below.
- 4.17 Connect:
- The flue system, see Installation, Section 8.
 - Gas services, see Installation, Section 2, using the opening in the side of the chimney breast for access.

After commissioning:

- 4.18 Finish the sides of the chimney breast, see Diagram 10.

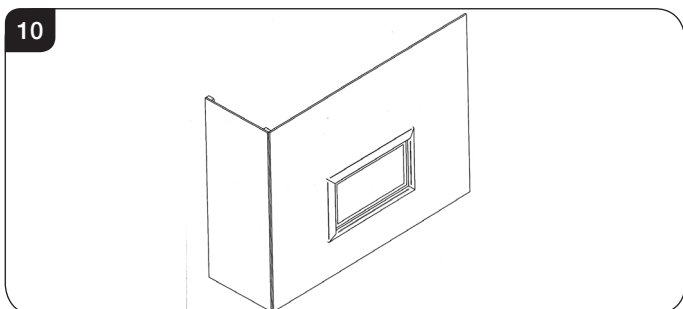

5. Studwork for Studio Edge installation kit

There is an optional Studio Edge Installation Kit available for installing the appliance without a frame: Studio 1 BF Code No. 8727BF EK01, Studio 2 BF Code No. 8727BF EK02, Studio 3 BF Code No. 8727BF EK03.

Using the installation kit:

- 5.1 Fit the four metal brackets of the kit to the appliance, see Diagram 11.

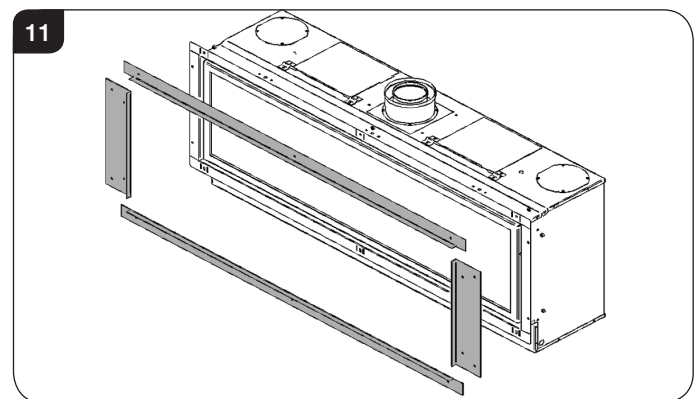

- 5.2 Fix foam seal to the rear of the outer flange of the appliance, see Diagram 12.

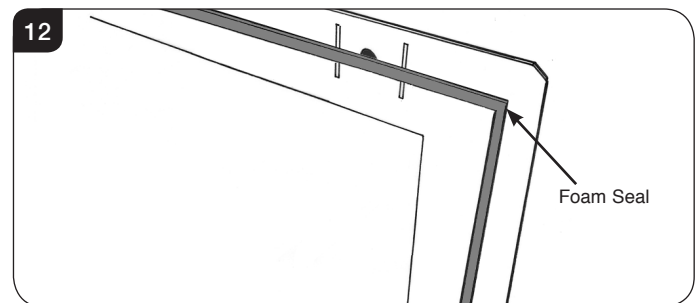

- 5.3 Put vertical studwork at minimum clearance to the side of the appliance (50mm).
- 5.4 Secure to the vertical studwork through the holes in the metal brackets fitted to the appliance.
- 5.5 The kit has been designed so that non-combustible board can be taken right up to the edge of the four brackets, see Diagrams 12 & 14.

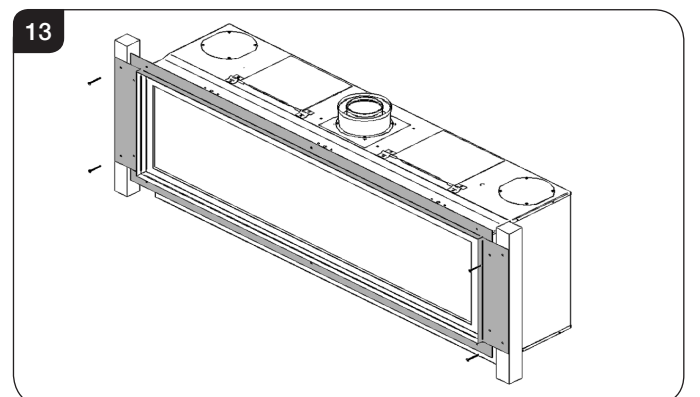

Installation Instructions

14

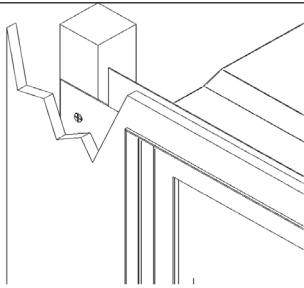

- 5.6 Build the studwork chimney breast to the desired size.
- 5.7 Ensure all clearances to combustible material are maintained, see Section 3.
- 5.8 Decide on flue requirements.
- 5.9 Cut a hole for the flue exit, see Installation Instructions, Flue Assembly.

15

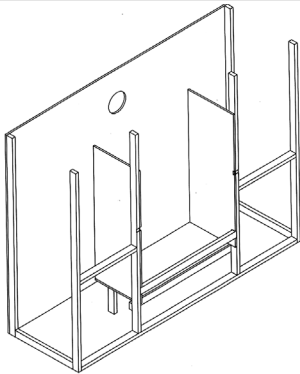

- 5.10 Fit non-combustible board to the studwork above the appliance. This should extend a minimum of 400mm above the appliance.
- 5.11 Fit plasterboard to the remaining chimney breast front.
- 5.12 Connect the flue system and gas services using the opening in the side of the chimney breast for access.
- 5.13 After commissioning, finish the sides of the chimney breast, see Diagram 16.

16

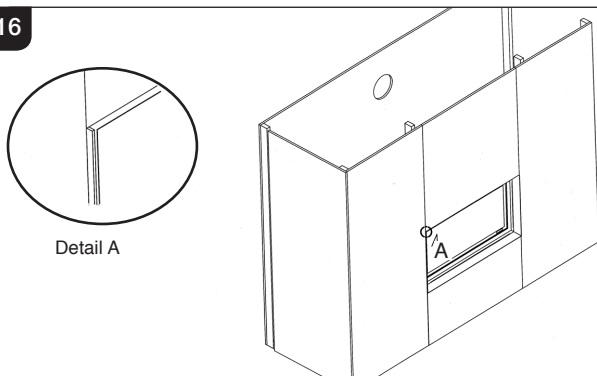

- 5.14 Apply a plaster finish to the chimney breast using heat resistant plaster in the area directly above the appliance.

6. Studwork for Cool Wall installation kit

For this cool-wall installation, the convected heat produced by the appliance is channelled into the chimney cavity and vented at the top.

The cool wall installation kit is provided unfinished. This allows the kit to be finished to match the front face decor.

There is an optional Studio Cool Wall Installation Kit available for installing the appliance without a frame: Studio 1 BF Code No. 8727BFCW01, Studio 2 BF Code No. 8727BFCW02, Studio 3 BF 8727BFCW03.

Using the fixing kit:

- 6.1 Fit the four metal brackets of the kit to the appliance, see Diagram 17. There is a deliberate gap at the top for convected heat.

17

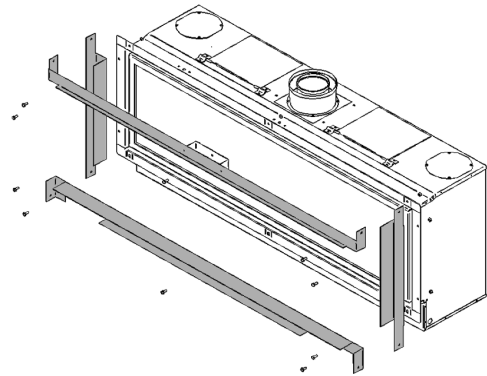

- 6.2 This now determines the width of your two vertical studwork supports. The kit has been designed so that non-combustible board can be taken right up to the edge of the four brackets, see Diagrams 18 & 19.

18

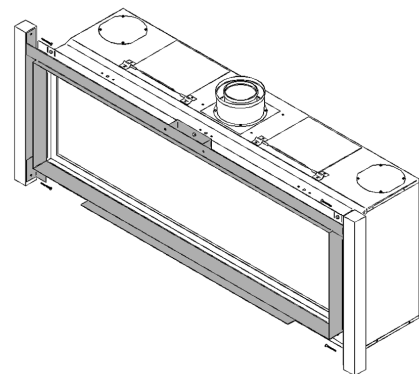

19

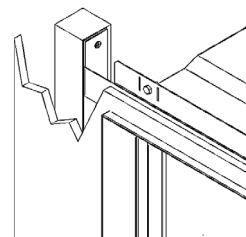

Installation Instructions

- 6.3 Fix the left and right metal brackets into the studwork
Build the studwork chimney breast to the desired size.
- 6.4 Ensure all clearances to combustible material are maintained, see Section 3.
- 6.5 Decide on flue requirements.
- 6.6 Cut a hole for the flue exit, see Installation Instructions, Flue Assembly.

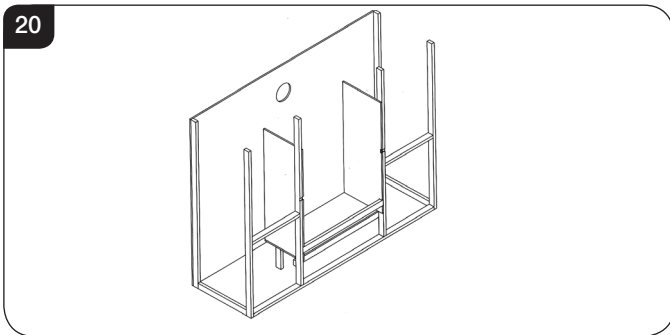

- 6.7 Fit non-combustible board to the studwork above the appliance. This should extend a minimum of 400mm above the appliance.
- 6.8 Fit plasterboard to the remaining chimney breast front.
- 6.9 Connect the flue system and gas services using the opening in the side of the chimney breast for access.
- 6.10 After commissioning, finish the sides of the chimney breast, see Diagram 21.

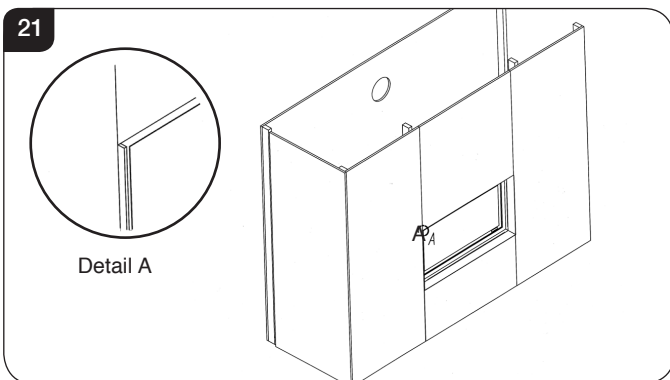

- 6.11 The top of the chimney breast must have a minimum 200cm² vent.
- 6.12 Apply a plaster finish to the chimney breast.

7. All types of installation into Studwork - Wall Box & Batteries

i Please note: As an optional extra Gazco can provide a mains adapter to supply constant power to the appliance control box instead of the battery pack.

If installing an appliance with the adapter make provision for a mains power socket within 1.5m of the control box and follow the instructions provided.

- 7.1 Decide on the position for the wall box containing the batteries and wall switch.

A combined battery power supply and touch control cable is supplied and pre-fitted to the appliance control. Provision is made for the cable to exit either the left or right of the appliance through the grommet. The cable is 3 metres long.

When deciding the route of the cables consideration must be given to avoiding contact with the appliance and the flue system.

- 7.2 Correctly position the three new high quality (Duracell or similar) size C batteries into the battery holder. Replace the cover by sliding it on to the battery holder.

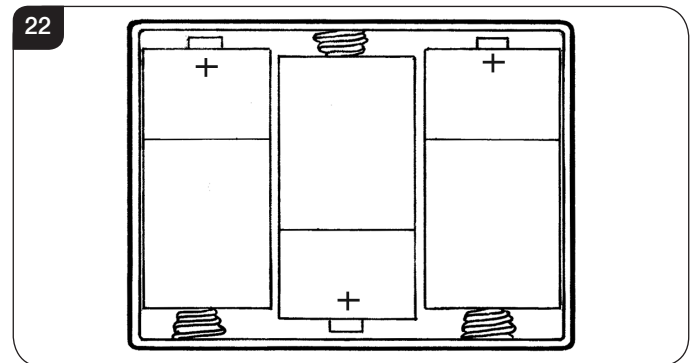

- 7.3 Slide the battery box into its housing in the back of the wall plate, see Diagram 23.

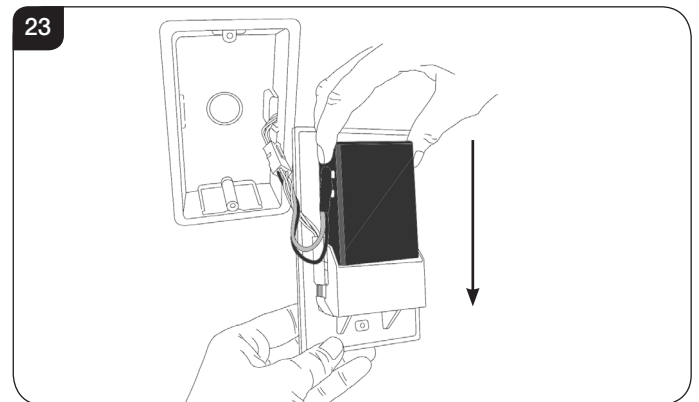

- 7.4 Ensure both sets of wires are connected, see Diagrams 24 & 25. **When replacing the 4 pronged connector ensure that the arrows are aligned.**

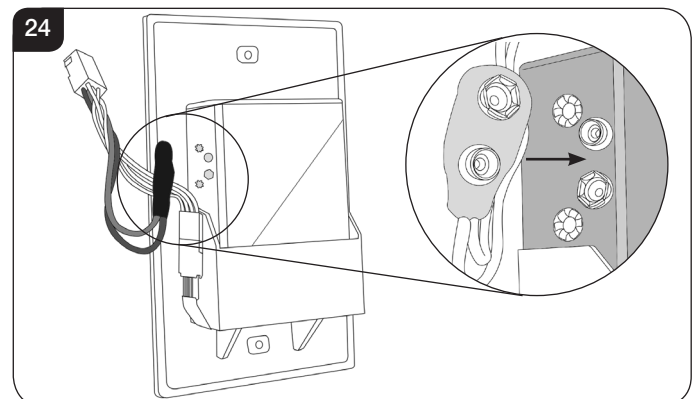

Installation Instructions

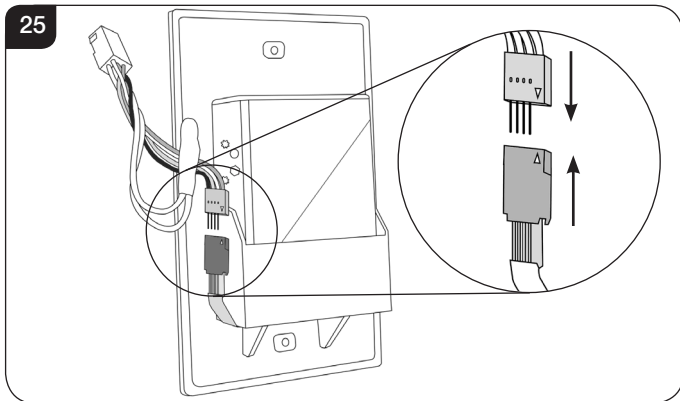

7.5 Connect the cable from the appliance to the touch pad cable, see Diagram 26.

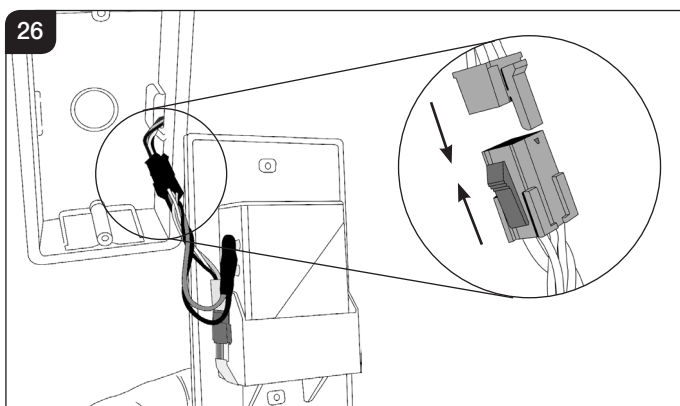

7.6 **IMPORTANT: THE WALL SWITCH MUST BE INSTALLED USING THE PLASTIC DRY LINING BOX SUPPLIED.**

Secure the wall plate to the dry lining box with the 2 x screws provided, see Diagram 27.

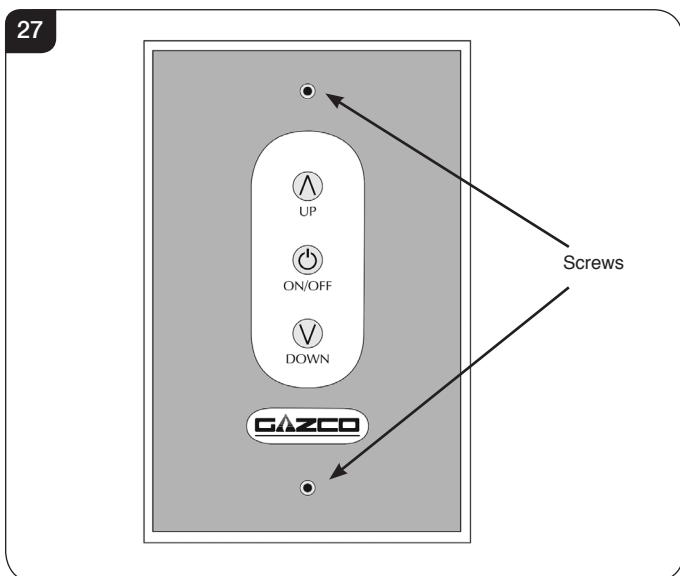

PLEASE ENSURE NO WIRES ARE TRAPPED BEFORE REPLACING THE WALL PLATE. THE TOUCH PAD LEAD IS EASILY DAMAGED.

8. Flue Assembly

8.1 See Site Requirements, Section 2, Flue Options.

TAKE CARE WHEN MARKING OUT FOR THE FLUE AS IT IS DIFFICULT TO MOVE AFTER INSTALLATION. IF A RESTRICTOR IS REQUIRED FIT THIS BETWEEN THE SMALL OUTLET SPIGOT AND THE AIR DUCT, SEE DIAGRAM 26. REFER TO TECHNICAL SPECIFICATIONS FOR RESTRICTOR SIZE.

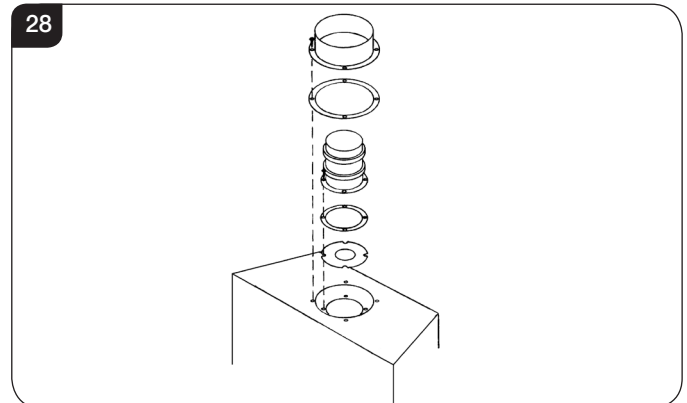

8.2 A 152mm (6") diameter hole in the wall is required to install the flue. This can be achieved by using either:

- a) Core drill
- b) Hammer and chisel

8.3 Drill small holes around the circumference when using method b). Make good both ends of the hole.

8.4 Allow enough room either above or to the side of the appliance to assemble the flue on top.

8.5 Assemble a horizontal flue in the following order:

- Vertical section
- 90° elbow
- Horizontal plus terminal

8.6 Support the opening of a masonry installation with a lintel.]

8.7 Only the horizontal terminal section can be reduced in size.

To find the length:

8.8 Measure from the outside of the wall to the stop on the 90° elbow.

8.9 **Add 10mm to the outlet end.**

8.10 Measure from the edge of the slots closest to the wall.

8.11 Mark around the flue, see Diagram 29.

Installation Instructions

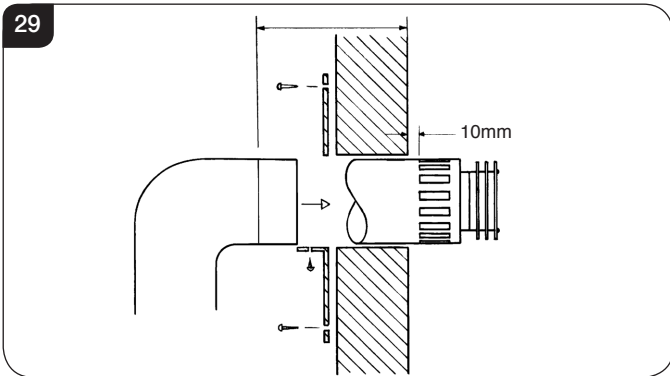

A wall plate is supplied to fix the flue to the wall:

- 8.12 Bend the tab to 90°.
- 8.13 Assemble the plate onto the flue but do not secure to wall until the flue is fully assembled, see Diagram 27.
- 8.14 The cardboard fitment in the terminal is used to support the flue whilst it is cut to length. **ONCE CUT TO SIZE REMOVE THE CARDBOARD REMNANT**, see Diagram 30.

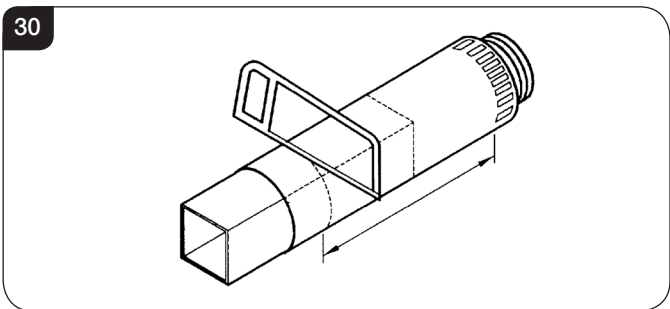

- 8.15 Remove the compression elbow from the appliance and connect it to the gas supply pipe.

As the appliance is fitted into the enclosure:
- 8.16 Pass the elbow and supply pipe through the silicone panel on the LEFT HAND side.
- 8.17 **PURGE THE SUPPLY PIPE.** This is essential to expel any debris that may block the gas controls.
- 8.18 Connect the elbow to the appliance inlet pipe, see Diagram 31.

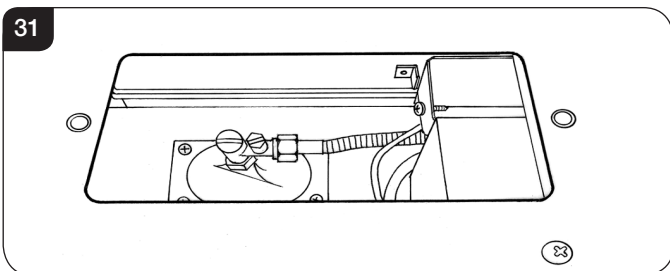

- 8.19 Connect a suitable pressure gauge to the test point located on the inlet fitting.
- 8.20 Turn on the gas.

- 8.21 Light the appliance and check for leaks.
- 8.22 Turn the appliance to maximum and check that the supply pressure is as stated on the data badge.
- 8.23 Turn off the gas and replace the test point screw.
- 8.24 Turn the gas back on and check the test point for leaks.

9. Assembling the Appliance

- 9.1 Add the stone chippings, glass granules or vermiculite, making sure they are flattened and level with the rim of the tray.

TAKE CARE NOT TO SPILL THE FUEL EFFECT INTO THE PILOT AREA. ONLY GENUINE GAZCO PARTS CAN BE USED IN THIS APPLIANCE.

Vermiculite Only: Use the exact amount of vermiculite supplied. This is just enough to cover the burner.

ENAMEL LINERS

For Studios 1 and 3 the back panel is already in place:

- 9.2 Place the bottom panel(s) at the base of the appliance.

Studio 3 only: Secure the two base panels with screws.

Studio 2 only: Locate the bottom edge of the liner behind the bracket on the support bar.

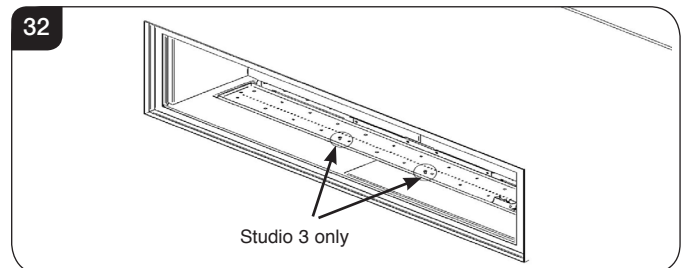

- 9.3 Slide the side panels into position.

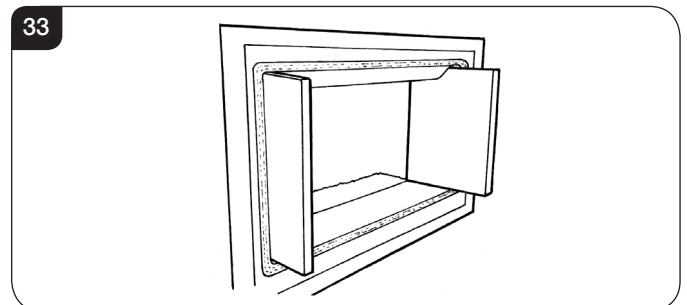

- 9.4 The Studio appliances have the option of two different liner finishes:
Vermiculite
Black Reeded Panels

NOTE: ALL FRONT PANELS AND THE STUDIO 3 REAR PANELS ARE IN TWO PIECES.

Installation Instructions

STUDIO 1 & 2: HOLD THE REAR PANELS UNTIL ALL THE OTHER PANELS ARE IN PLACE AS THEY CAN FALL FORWARD.

STUDIO 3 HAS A TOP BRACKET TO SECURE THE PANELS THIS MUST BE REMOVED PRIOR TO ATTEMPTING TO FIT THE REAR PANELS.

- 9.5 Place the rear panel(s) behind the locating bracket on the rear support bar.
- 9.6 Centralise the rear panel(s) with the chamfers touching and pushed together, see Diagram 34.

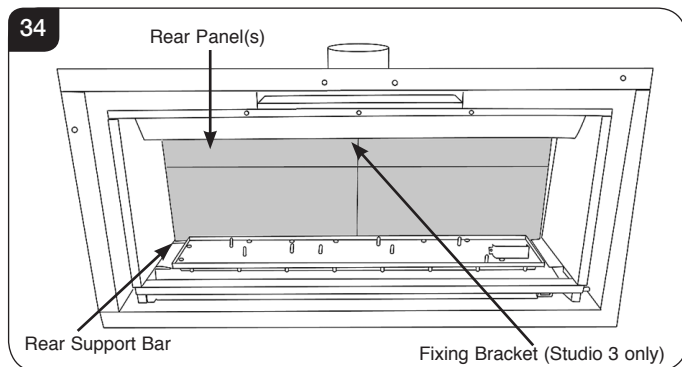

If installing the panels on a Studio 3 model replace the L shaped fixing bracket at the top rear of the firebox to hold the two rear liners in place.

- 9.7 Place the lower side and front panels in position so the chamfers meet at the front edge of the burner.
- 9.8 Ensure the two-piece front panels are engaged against the centre support tags on the burner and are pushed together in the middle, see Diagram 33.

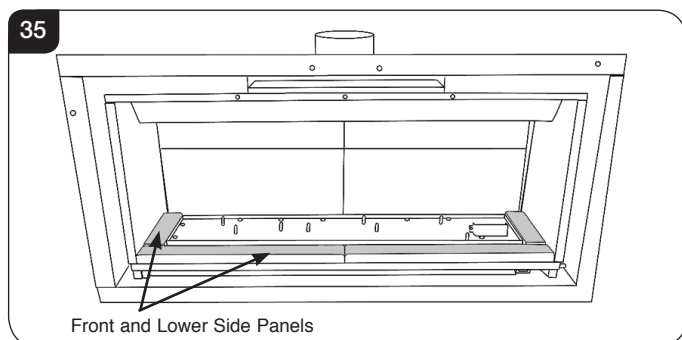

- 9.9 Slide the two side panels up to the rear panel, see Diagram 34.

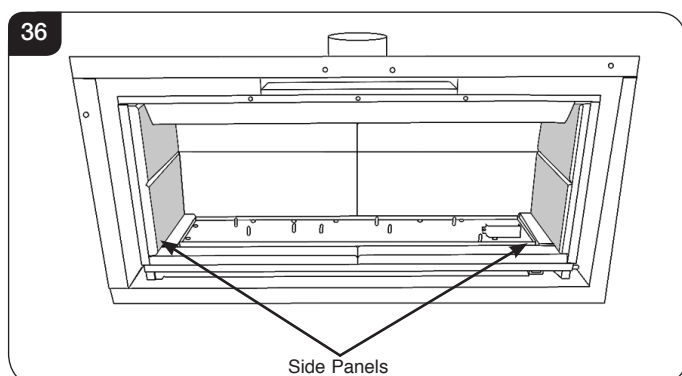

NOTE: THE HORIZONTAL CHAMFERS MUST ALIGN ON THE REAR AND SIDE PIECES.

10. Arrangement of the fuel bed

Advice on handling and disposal of fire ceramics



The fuel effect of the log version of this appliance is made from Refractory Ceramic Fibre (RCF), a material which is commonly used for this application.

Protective clothing is not required when handling these articles, but we recommend you follow normal hygiene rules of not smoking, eating or drinking in the work area and always wash your hands before eating or drinking.

To ensure that the release of RCF fibres are kept to a minimum, during installation and servicing a HEPA filtered vacuum is recommended to remove any dust accumulated in and around the appliance before and after working on it. When servicing the appliance it is recommended that the replaced items are not broken up, but are sealed within heavy duty polythene bags and labelled as RCF waste.

RCF waste is classed as stable, non-reactive hazardous waste and may be disposed of at a licensed landfill site.

Excessive exposure to these materials may cause temporary irritation to eyes, skin and respiratory tract; wash hands thoroughly after handling the material.

- 10.1 **White Stone and Glass Fuel Effects:** To replace the white stone effect chippings or glass granules, make sure they are flattened so they are level with the rim of the tray.
- 10.2 **Vermiculite for Log Layout:** Use the entire bag of supplied Vermiculite.

TAKE CARE NOT TO SPILL STONE EFFECT CHIPPINGS, GLASS GRANULES OR VERMICULITE INTO THE PILOT AREA. ONLY USE THE FUEL EFFECT SUPPLIED BY GAZCO IN THIS APPLIANCE.

Installation Instructions

11. Log Layout

LOGS MUST BE POSITIONED ACCORDING TO THE FOLLOWING INSTRUCTIONS TO GIVE THE CORRECT FLAME EFFECT

Layout for Studio 1

- 11.1 Use all the vermiculite to fill the burner tray and spread evenly across the whole burner.

- 11.2 Rest the ceramic bark against the front face of the pilot shield, see Diagram 37.

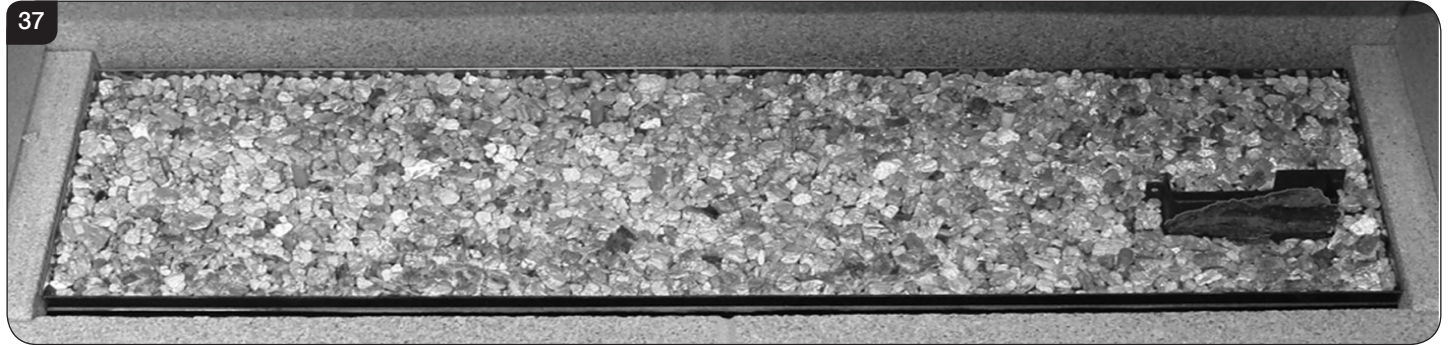

All logs can be identified by a letter (A - H) on their underside. The first three logs, A, B and C, also have holes to locate each onto a burner stud.

- 11.3 Working from left to right place logs A, B and C onto their studs, see Diagram 38.

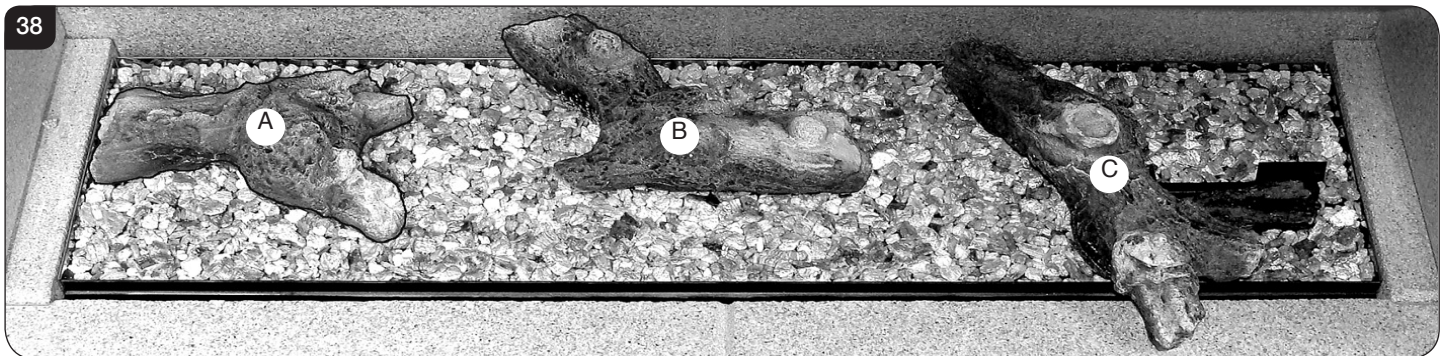
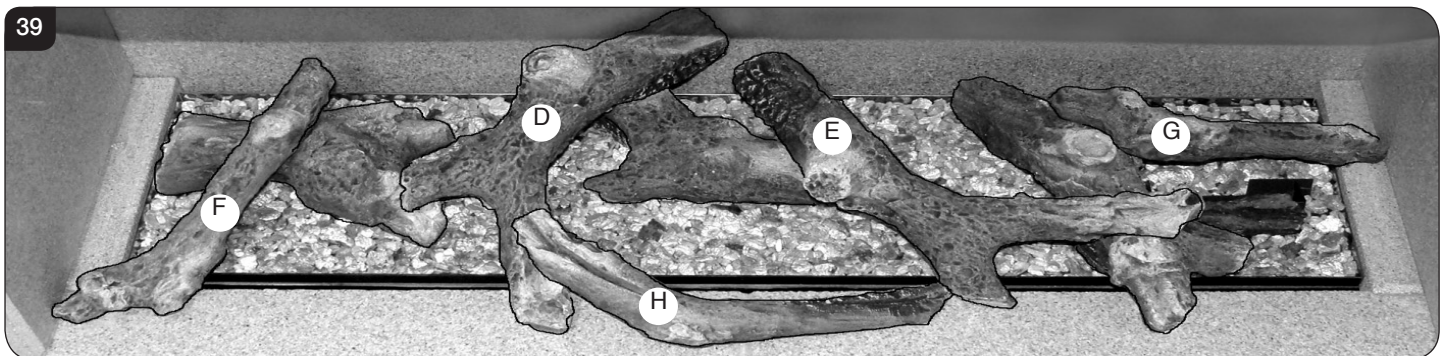

Diagram 39 shows the layout of logs D to H.

- 11.4 Log D has a recess on the underside to fit onto the stud of Log B at the back left. The small branch of the log rests on Log A.

- 11.5 A recess in the back of Log E fits the stud on Log B and its long branch rests snugly behind a wood knot of Log C.



- 11.6 Log F fits centrally onto Log A with its front edge resting on the front panel.

- 11.8 The small branch underneath Log H rests on the front panel and overlaps Log D just touching Log E.

- 11.7 Log G is centrally positioned around the moulded wood knot of Log C and rests against the right side panel crossing the pilot shield beneath.

Installation Instructions

11.9 Separate the Embaglow material into smaller pieces and pull into shape to create a fine layer.

11.10 Place the pieces of Embaglow between the logs in the highlighted areas shown in Diagram 40. Ensure the material is placed loosely between the logs to create a random glow.



Layout for Studio 2

11.11 Preparation of vermiculite and the ceramic bark pilot shield is the same as for Studio 1, see 11.1 and 11.2..

All logs can be identified by the letters (A - J) on their underside. The first four logs, I, A, B and C also have holes to locate each onto a burner stud.

11.12 Place logs I, A, B and C onto their studs, see Diagram 41.

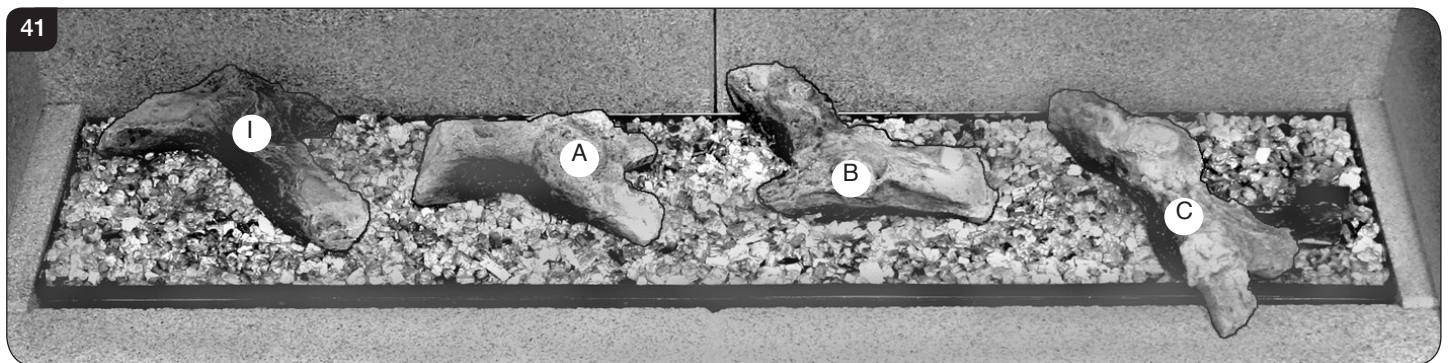
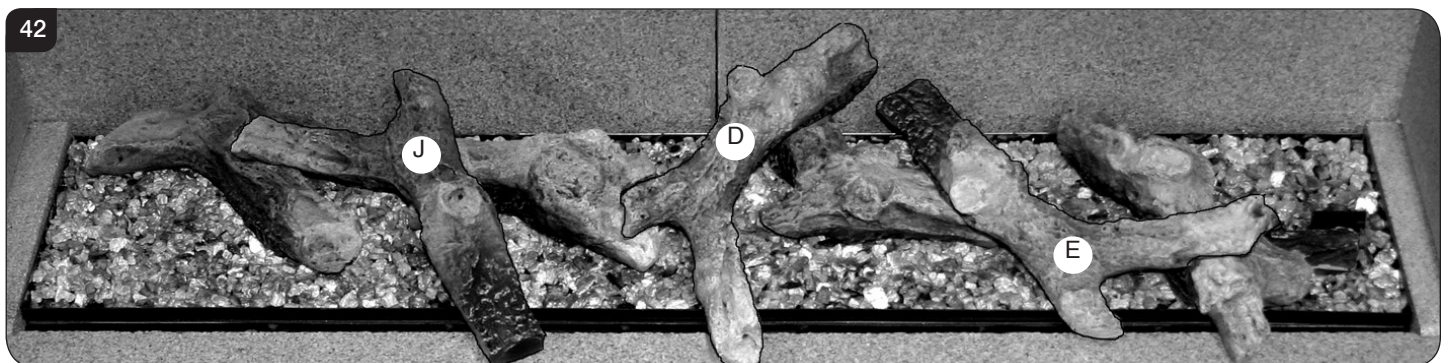

Diagram 42 shows the layout of logs D, E and J.

11.13 Log D has a recess on the underside to fit onto the stud of Log B at the back left. The small branch of the log rests on Log A.

11.14 A recess in the back of Log E fits the stud on Log B and its long branch rests snugly behind a wood knot of Log C.



11.15 The underside of log J has a moulded 'stop'. This rests about 12mm in from the left edge of Log A. The left branch of Log J also rests in the recess in Log I, see Diagram 42.

Installation Instructions

Diagram 43 shows the layout of the last four logs, F, G and two of log H:

- 11.16 Log F fits centrally onto Log I with its front edge resting on the front panel.
- 11.17 Log G is centrally positioned around the moulded wood knot of Log C and rests against the right side panel crossing the pilot shield beneath.

- 11.18 The first Log H rests on the front panel, overlapping Log D and touching Log E.
- 11.19 The second Log H rests anywhere on the front panel between F and J. **DO NOT LET THIS LOG OVERLAP THE BURNER.**

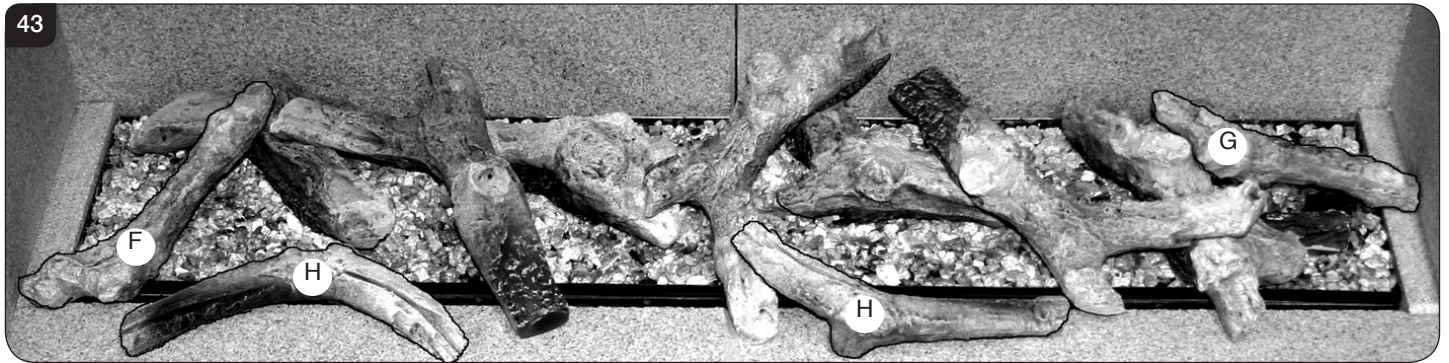

- 11.20 Separate the Embaglow material into smaller pieces and pull into shape to create a fine layer.

- 11.21 Place the pieces of Embaglow between the logs in the highlighted areas shown in Diagram 44. Ensure the material is placed loosely between the logs to create a random glow.



Layout for Studio 3

- 11.22 Use all the vermiculite to fill the burner tray and spread evenly across the whole burner.
- 11.23 Rest the ceramic bark against the front face of the pilot shield, see Diagram 43.

All logs can be identified by the letters (A - K) on their underside. The first five logs, K, I, A, B and C also have holes to locate each onto a burner stud.

- 11.24 Place logs K, I, A, B and C onto their studs as illustrated in Diagram 45.

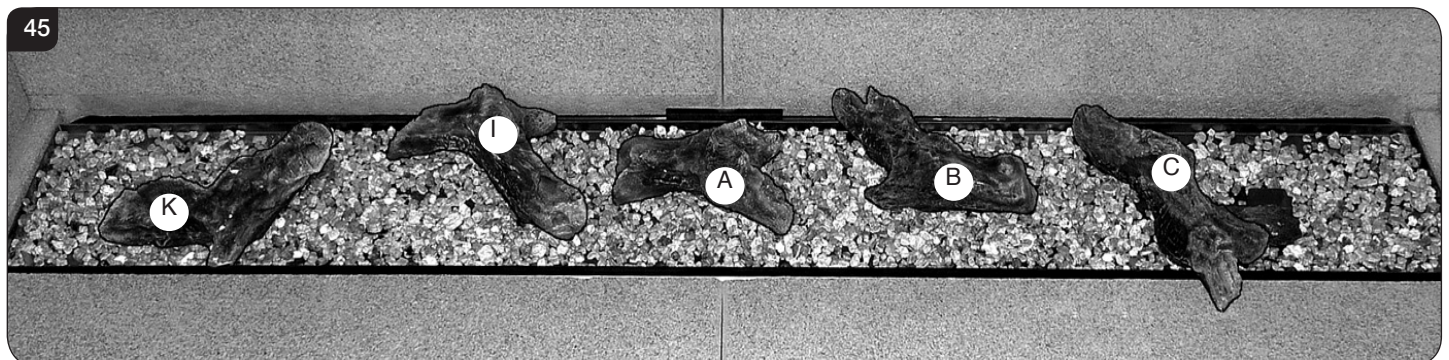

Installation Instructions

Diagram 46 shows the layout of logs F, E, J, D, E and C. Working from left to right:

- 11.25 Log F rests in an indent in Log K with the letter on the underside facing down and a top stud lying towards the back left of the burner tray.

- 11.26 Log E fits onto the stud on the back right of Log K. The right-hand branch rests against Log I, see Diagram 46.

- 11.27 The underside of log J has a moulded 'stop'. This rests about 12mm in from the left edge of Log A. The left branch of Log J rests in a recess in Log I, see Diagram 46.

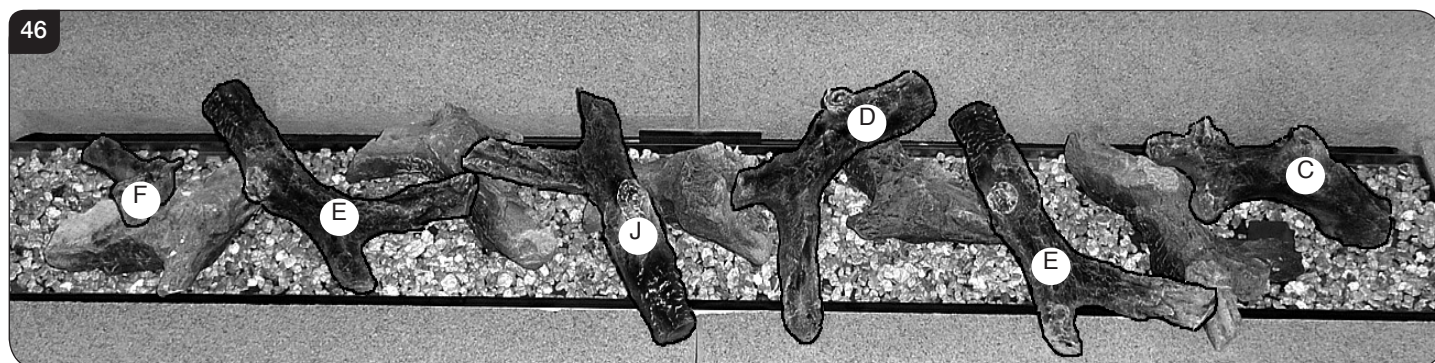

- 11.28 Log D has a recess on the underside to fit onto the stud of Log B at the back left. The small branch of the log rests on Log A.

- 11.29 A recess in the back of Log E fits the stud on Log B and its long branch rests snugly behind a wood knot of Log C.

- 11.30 The fork of the branches of Log C rest around the wood knot of Log C beneath and cross the pilot shield below.

Diagram 45 shows the layout of logs D, E, H, G, H. Working from left to right:

- 11.31 Log D's recess fits the stud at the back left of Log F. The branch must overlap the side and front edge panels, see Diagram 47.

- 11.32 Log F rests on a little notch on the lower branch of Log E and overlaps the front edge panel, see Diagram 47.

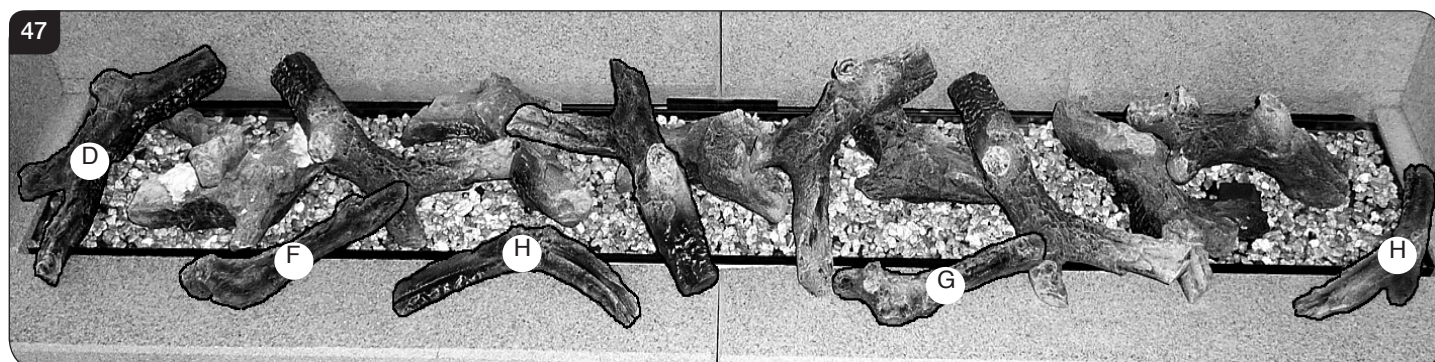

- 11.33 Log H rests anywhere on the front panel between F and J.

- 11.34 Log G rests against the lower branch of Log E, see Diagram 47.

- 11.35 The second Log H arches across the side and front panels. **DO NOT LET THIS LOG SIT ON THE BURNER TRAY.**

- 11.36 Separate the Embaglow material into smaller pieces and pull into shape to create a fine layer.

- 11.37 Place the pieces of Embaglow between the logs in the highlighted areas shown in Diagram 48. Ensure the material is placed loosely between the logs to create a random glow.

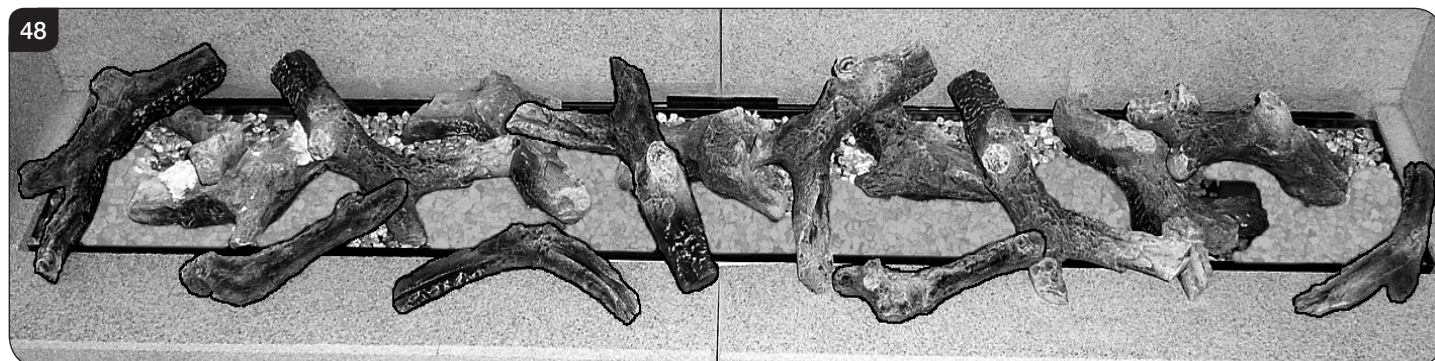

Installation Instructions

12. Completion of Assembly

- 12.1 To fit the window frame keep the frame in the upright position with the locks uppermost.
- 12.2 Offer the frame to the foot of the opening.
- 12.3 Slide the frame to the right to locate the right hinge pin.

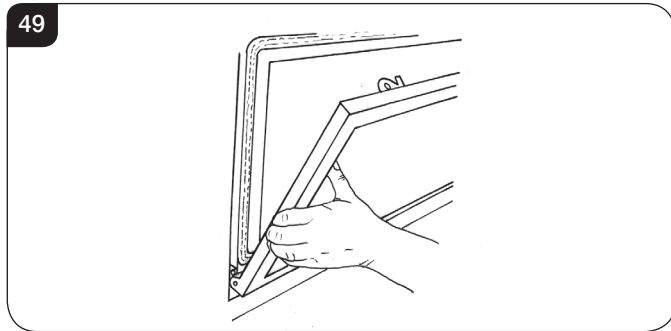

- 12.4 Manoeuvre the frame up towards the left side to locate the left hinge pin.
- 12.5 Slide onto the hinge with a right movement.
- 12.6 Secure in place with a spring clip at the right hinge pin, see Diagram 50.

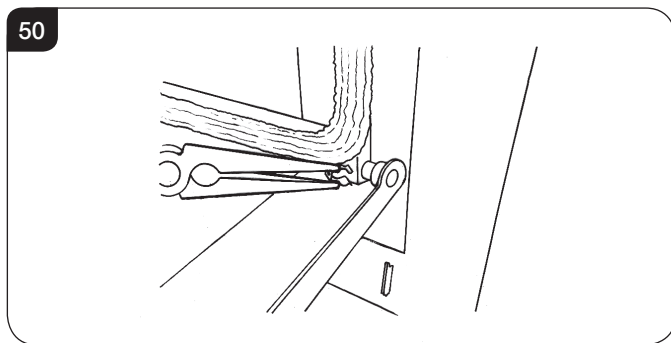

- 12.7 Close the window.
- 12.8 Using the hexagon key provided close the window locks by moving from open to shut towards the window centre, see Diagram 51

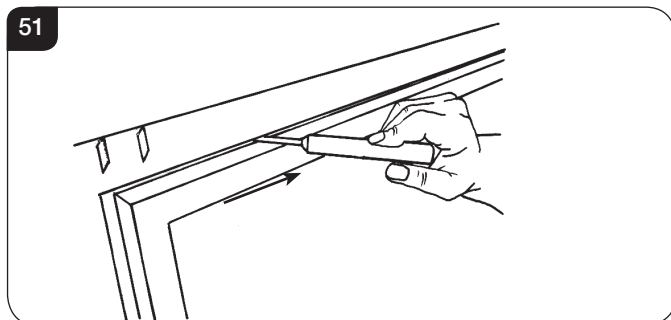

- 7.9 **When closing the door ensure the door catches are fully engaged.**



UNDER NO CIRCUMSTANCES SHOULD THE APPLIANCE BE USED WITHOUT THE CATCHES HOLDING THE DOOR IN PLACE.

13. Decorative Frame

The fitting of the frame requires 2 people.

To attach the frame:

- 13.1 Rest the lower fixing angle of the frame onto the bottom brackets attached to the appliance flange.
- 13.2 Lift the upper angle onto the top brackets and lower, see Diagram 52.

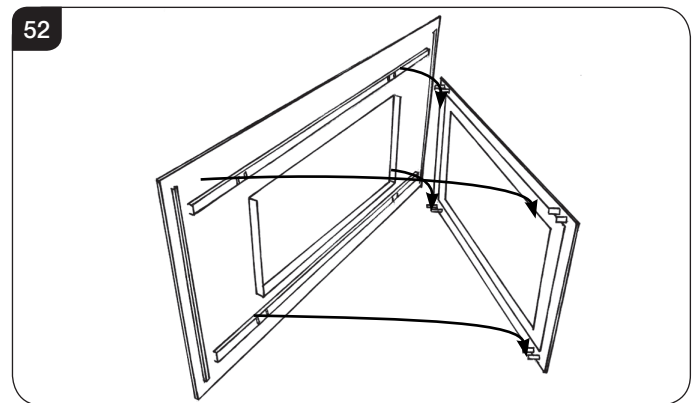

14. Operating the Studio

- 14.1 The appliance has 4 flame settings:
 - 1. High.
 - 2. Medium.
 - 3. Low.
 - 4. Standby (Pilot only).
- 14.2 Both touch pad and handset allow you to manually switch between flame settings.
- 14.3 The Thermostatic handset also allows to set the appliance to automatically regulate the room temperature.

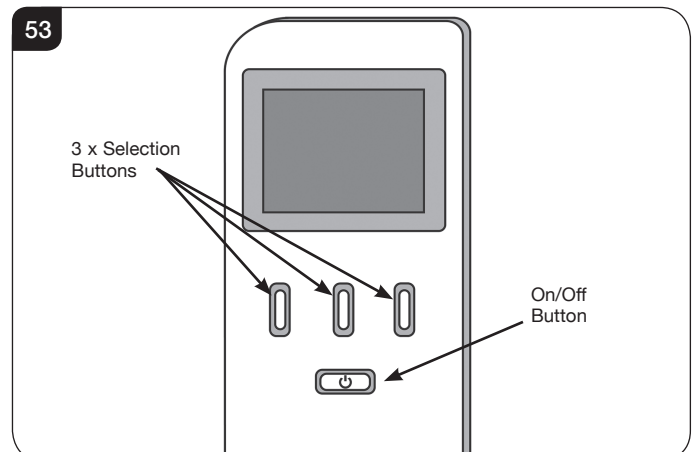

Installation Instructions

Before using the remote control:

- 14.4 If there is no display on the LCD screen press any key.
- 14.5 When first powered, the handset displays the OFF screen. The handset may be locked as indicated by the padlock symbol (🔒), see Diagram 54.

NOTE: To select a function from the options displayed at the bottom of the screen press the button directly below the desired function.

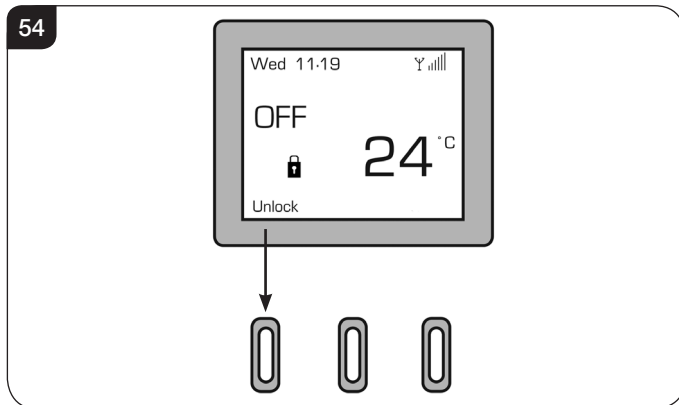

- 14.6 To unlock the handset select Unlock followed by OK - the symbol will change to an open padlock (🔓).
- 14.7 There are 3 different modes available for controlling and operating the appliance for full operating details see Section 2, User Instructions.

When a command from the handset is received a beep will sound and the LED on the handset will briefly illuminate.

NOTE: The LED flashes every 4 seconds to show that it is communicating with the appliance. After each command has been accepted the LED will cease flashing until the command has been carried out. Wait until the LED resumes flashing before giving another command.

Manual Mode

Switching the Appliance ON:

- 14.8 To light the appliance press the On/Off (🔌) button, this will bring up the LCD screen. Select the 'On' option on the left of the screen immediately followed directly by the OK button, a single beep will sound.

After the start up cycle has completed the appliance will light on the high flame setting (this can take up to 20 seconds).

Select the 'Manual' option on the screen to control the appliance.

Decreasing the Flame Height:

- 14.9 From the high flame setting press DOWN (↓) once to lower the flame to the medium setting.
- 14.10 From the medium flame setting press DOWN (↓) once to lower the flame to the low setting.

- 14.11 From the low flame setting press DOWN (↓) once to put the appliance in Standby mode (Pilot only).

Increasing the Flame Height:

- 14.12 To light the appliance when it is in Standby mode press UP (↑) once. The appliance will light on the **Low** flame setting.
- 14.13 From the low setting press UP (↑) once to increase the flame setting to medium.
- 14.14 From the medium setting press UP (↑) once to increase the flame setting to high.



WARNING: IF THE APPLIANCE FAILS TO LIGHT OR BECOMES EXTINGUISHED IN USE, WAIT 3 MINUTES BEFORE ATTEMPTING TO RELIGHT.



IMPORTANT: YELLOW FLAMES TYPICALLY APPEAR WHEN THE APPLIANCE HAS REACHED NORMAL OPERATING TEMPERATURE. THIS CAN TAKE UP TO 30 MINUTES.

Switching the Appliance OFF:

- 14.15 To switch the appliance OFF press the On/Off (🔌) button once, see Diagram 53.

FOR FULL OPERATING INSTRUCTIONS AND TROUBLESHOOTING SEE USER SECTION.

15. Touch Pad Control

55



The touch pad control is located on the front of the wall switch and allows manual operation of the appliance, see Diagram 55.

With the touch pad it is possible to turn the appliance ON, OFF and control the flame setting.

NOTE: When using the touch pad buttons a beep will be emitted from the appliance to indicate an accepted command.

Installation Instructions

Lighting the appliance

15.1 Press the On/Off button once.

If the pilot fails to light, press the ON/OFF button to switch OFF. Wait for at least 30 seconds before attempting to relight.

15.2 After the start up cycle has completed the appliance will light on the **high flame setting** (this can take up to 20 seconds).

If the appliance is in Standby mode, pressing the UP (^) button will cause the main burner to ignite on the **Low flame setting**.

15.3 To increase the flame height press the UP (^) button.

15.4 To decrease the flame height press the DOWN (v) button.

15.5 When on the lowest flame setting pressing the Down (v) button will switch the appliance to Standby mode (pilot only).



WARNING: IF THE APPLIANCE FAILS TO LIGHT OR BECOMES EXTINGUISHED IN USE, WAIT 3 MINUTES BEFORE ATTEMPTING TO RELIGHT.



IMPORTANT: YELLOW FLAMES TYPICALLY APPEAR WHEN THE APPLIANCE HAS REACHED NORMAL OPERATING TEMPERATURE. THIS CAN TAKE UP TO 30 MINUTES.

To Switch the Appliance OFF:

15.6 To turn the appliance **OFF** press the On/Off button once.

Touch Pad Control Not Working

If the appliance is not operating with the touch pad control:

15.7 Replace the batteries in the wall switch unit, see Section 6, User Instructions.

15.8 If the appliance still fails to operate consult your installer or Gazco retailer.

Commissioning

1. Commissioning

1.1 Complete the Commissioning Checklist at the front of this manual covering:

- Flue checks
- Gas checks
- Log/fuel effect layout - flame picture

For working pressure test, use the access panel at the gas connection ensuring the burner is in position. Refer to Replacement Parts, Section 17.

1.2 Upon completion of the commissioning and testing of the installation and correct operation of the appliance, the installer must instruct the user how to operate the appliance.

1.3 Guide the user through the User Instructions paying particular attention to:

- a) Regular servicing (Section 12 of the User Instructions).
- b) Ventilation (Section 13 of the User Instructions) - point out the ventilation positions where applicable.
- c) Hot surfaces (Section 15 of the User Instructions).
- d) How the appliance works with the touch pad control (Section 5 of the User Instructions).
- e) How the appliance works with the remote control handset and the modes of operation (Section 2 of the User Instructions).
- f) How to change settings in the auto mode and program modes of operation.
- g) What to do if the appliance fails to operate (Section 16 of the User Instructions).

2. Pairing the appliance

i To access the control panel in order to pair the appliance it will be necessary to remove the Main Control Assembly, see Servicing Section 4.

If there is no communication between the remote control and the appliance after replacing the control box or the handset, it will be necessary to pair the two together.

Before starting the pairing process ensure the handset is programmed to Channel 'C' see Section 3.

- 2.2 Ensure batteries are fitted and working in the handset.
- 2.3 Check all leads and cables are connected correctly.
- 2.4 Ensure the handset is unlocked. To unlock the handset select Unlock followed by OK - the symbol will change to (□).

- 2.5 Press the ON/OFF button (⏻) on the handset and keep it depressed until the screen changes to the configuration menu. This may take up to 30 seconds and the screen may go blank before changing to the configuration screen.
- 2.6 When the configuration menu screen appears change the Pairing option to ON using the Change button.
- 2.7 Within 20 seconds press the yellow button on the control unit repeatedly until a single beep is heard confirming the pairing operation has been successful, see Diagram 1. This may be easier using a pencil, ball point pen or similar.

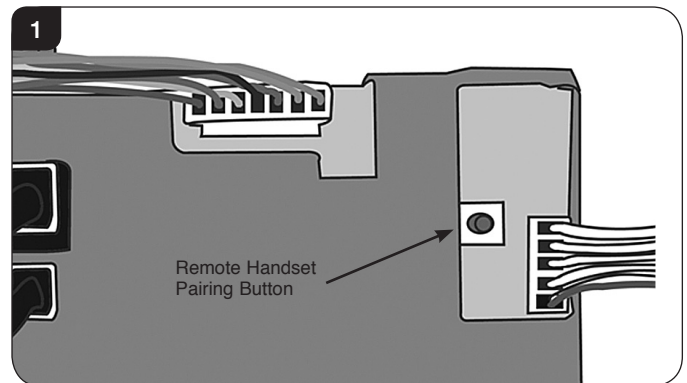

- 2.8 The remote handset will display a signal level in the top right hand corner. This may take up to 4 minutes.
- 2.9 Press the back button on the handset to return to the configuration menu and then again to return to the main menu.

3. Changing channel

i WHEN ATTEMPTING A NEW PAIRING PROCEDURE THE HANDSET SHOULD BE SET TO CHANNEL 'C'. IF THE APPLIANCE IS ALREADY SET TO CHANNEL 'C' BUT NO COMMUNICATION SIGNAL STRENGTH IS SHOWN ON THE HANDSET, IT WILL BE NECESSARY TO CHANGE THE COMMUNICATION CHANNEL USING THE FOLLOWING PROCEDURE.

- 3.1 Ensure the handset is unlocked. To unlock the handset select Unlock followed by OK - the symbol will change to (□).
- 3.2 Press the ON/OFF button (⏻) on the handset and keep it depressed until the screen changes to the configuration menu. This may take up to 30 seconds and the screen may go blank before changing to the configuration screen.
- 3.3 Press the button below the down arrow (↓) to scroll through the menu until 'Channel' is displayed.
- 3.4 The channel is normally pre-set to C. Press the button below 'Select' and then use the down arrow (↓) to set the handset to channel A or B.
- 3.5 Disconnect the batteries from the control box and reconnect after 10 seconds.
- 3.6 The remote handset will display a signal level in the top right hand corner. This may take up to 4 minutes, check the strength of the signal in the top right hand corner of the LCD display (⌘).

Servicing Instructions

Servicing/Fault Finding Charts

1. Servicing Requirements

IMPORTANT – The glass panel on this appliance should be checked for any signs of damage on the front face of the glass panel (scratches, scores, cracks or other surface defects). If damage is observed, the glass panel must be replaced and the appliance must not be used until a replacement is installed. Under no circumstances should the appliance be used if any damage is observed. Please isolate the appliance until a replacement glass panel has been obtained and installed. Replacement glass panels can be purchased from Gazco via the retailer from which the appliance was purchased or any other Gazco distributor.

This appliance must be serviced at least once a year by a competent person.

All tests must be carried out in accordance with the current Gas Safe recommendations.

1.1 Before Testing:

- Conduct a gas soundness test for the property ensuring there are no leaks before servicing.
- Check the operation of the appliance before testing.

1.2 Special checks:

- Clean the burner using a vacuum cleaner with a soft brush attachment. Ensure all debris is removed from the burner ports.
- Clean away lint or fluff from the pilot.
- Clean away lint or fluff from under the burner.
- Check the spark gap on the pilot is correct.

1.3 Correct any faults found during the initial test.

1.4 Re-commission the appliance in accordance with Commissioning Procedures of these instructions.

1.5 Advise the customer of any remedial work undertaken.

REPLACE BATTERIES BEFORE ATTEMPTING TO RECTIFY ANY FAULTS.

IGNITION FUNCTIONAL CHECK 1

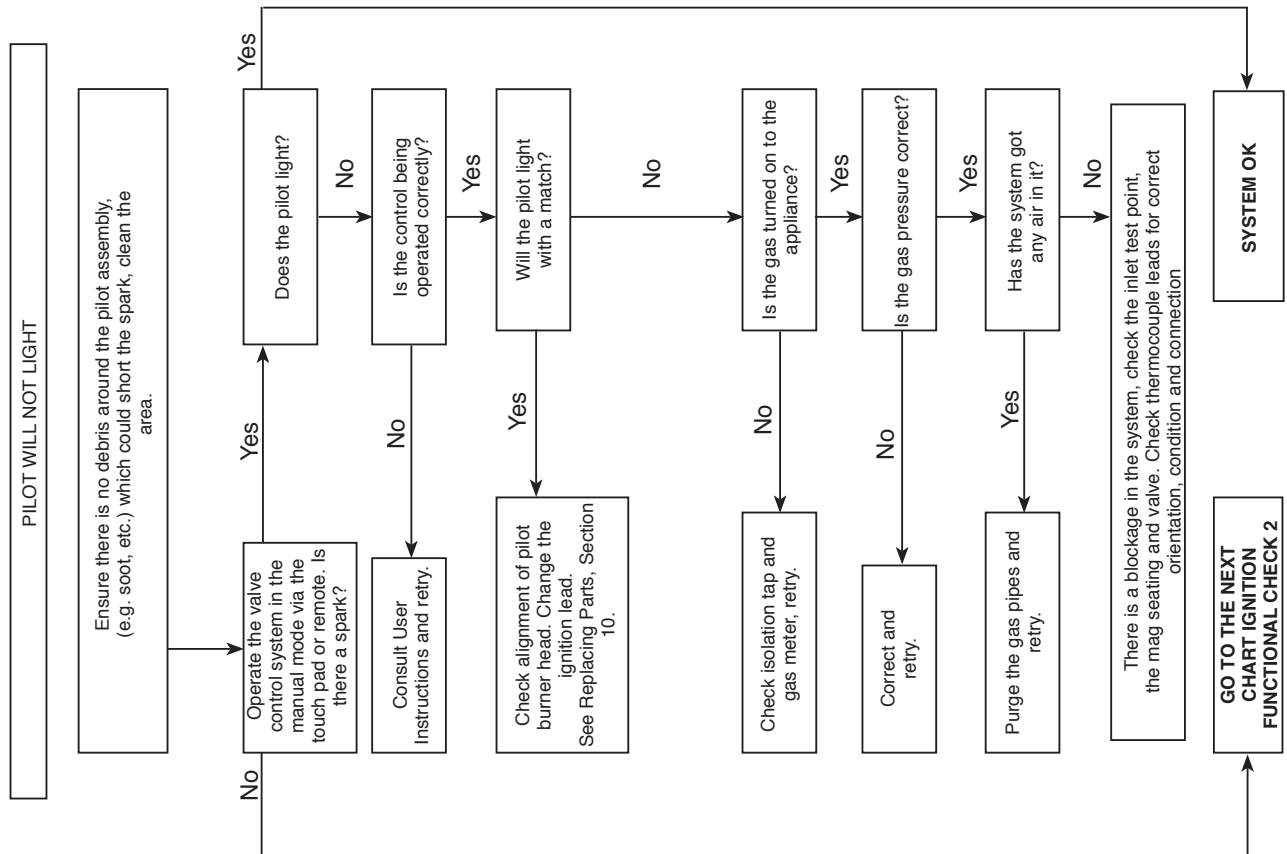

Servicing Instructions

Fault Finding Charts

FLAME FAILURE FUNCTIONAL CHECK 3

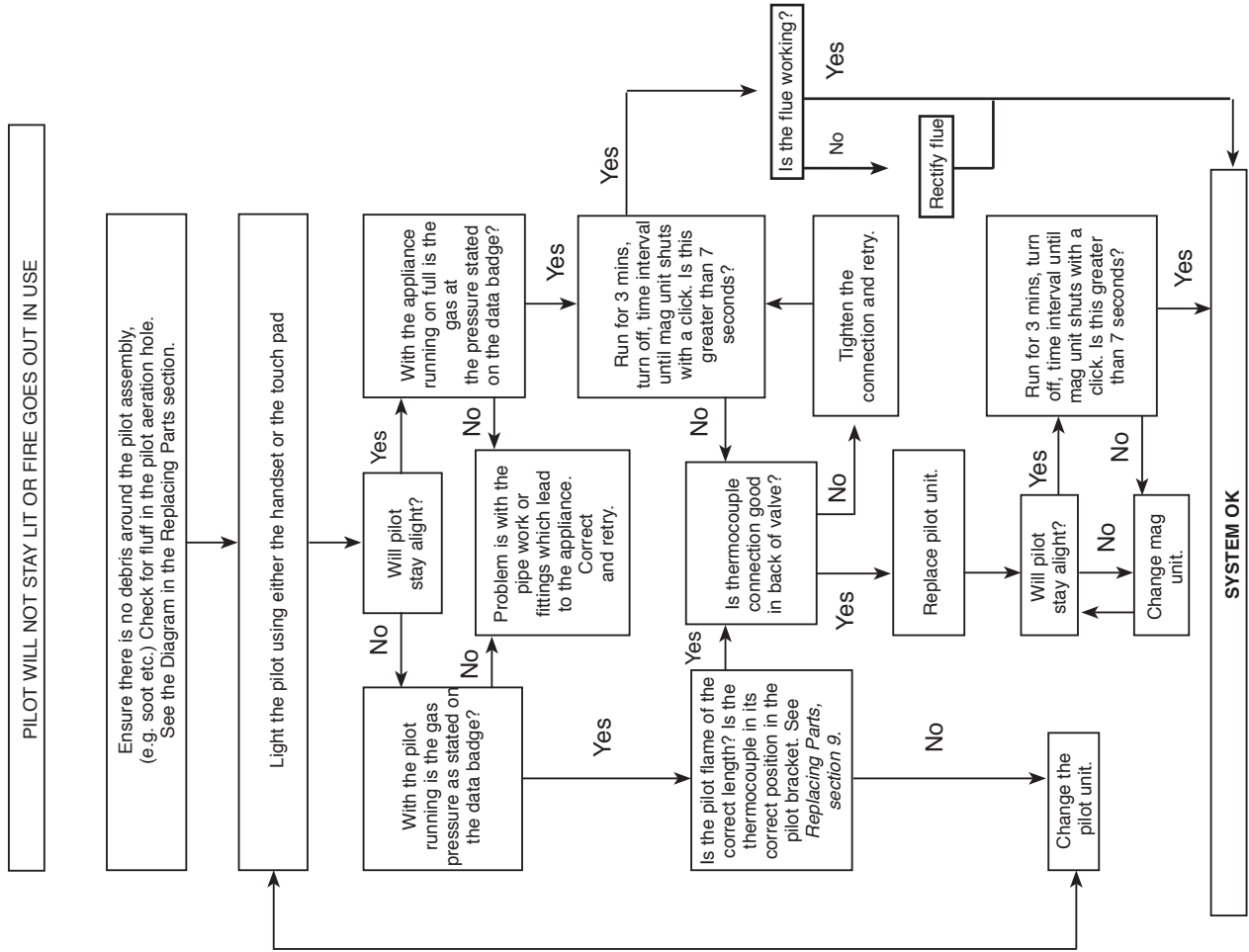

IGNITION FUNCTIONAL CHECK 2

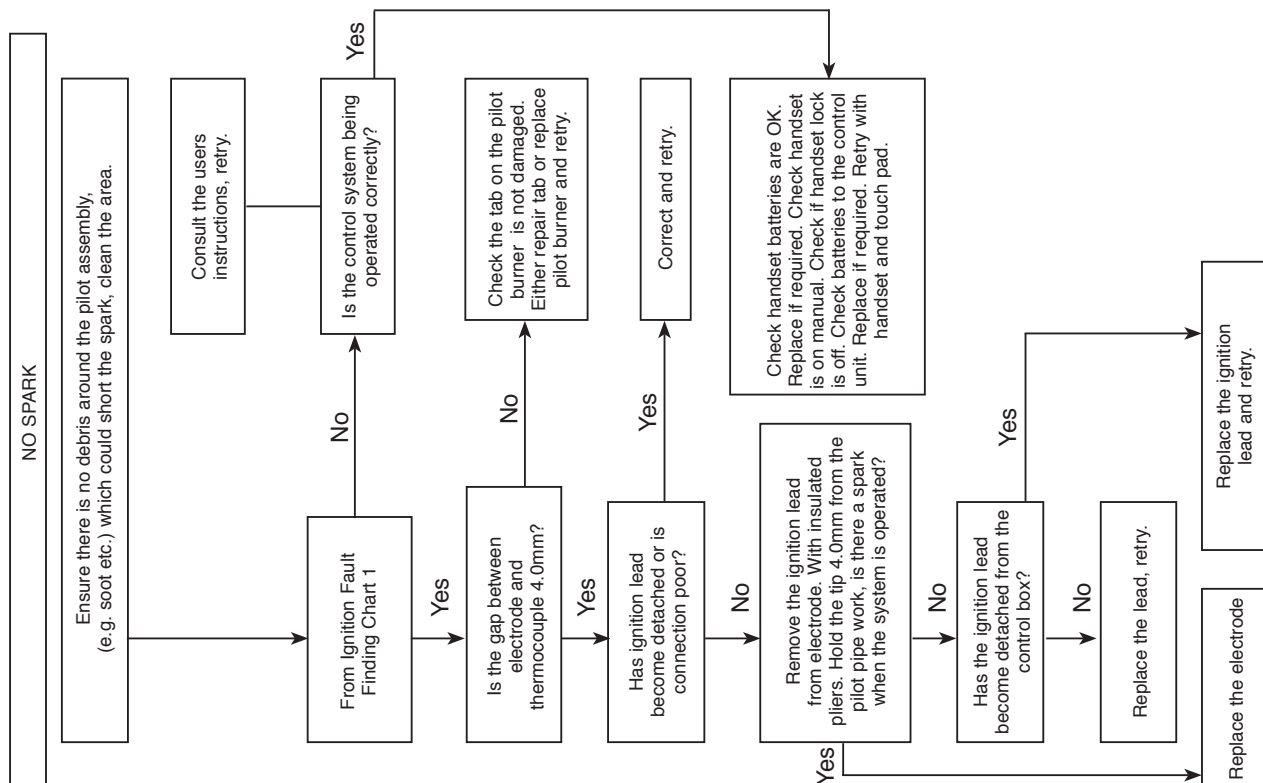

Servicing Instructions

Fault Finding Charts

ELECTRONIC CONTROL VALVE FAULT ANALYSIS

Problem	Cause	Error Message	LCD Display	Solution	
Does not ignite	No batteries or flat batteries in battery box	10 beeps	BATTERY ERROR	Place new batteries in battery box	
	ROM error	2 cycles of 3 beeps	ROM ERROR	Change control unit	
	Support test error	2 cycles of 5 beeps	SUPPORT ERROR	Connect earth cable from control box to valve	
	Bad reception of remote handset signal				Change batteries in the remote handset
					Check the reception of signal from a shorter distance
					Try pairing again
				Try changing the channel in the configuration menu	
	No response to touch control buttons	If LED is continuously on, the cable is connected the wrong way round			Ensure the touch control cable is correctly connected (see installation manual)
Cable loose or broken or connected wrong way round				Change touch control	
Supply cable to valve disconnected or broken	2 cycles of 5 beeps	SUPPORT ERROR	Reconnect or replace valve cable		
Ignition cable disconnected or broken			Connect ignition cable		
Sparks but no pilot ignition	Gas valve supply off or no gas			Check gas installation. Open gas valve	
	Valve cable disconnected or broken			Connect valve cable correctly	
	Interrupter cable disconnected or broken			Connect correctly or replace pilot cable	
Pilot ignites but does not stay on	Pilot is not warmed up			Check pilot flame and verify that it heats the pilot	
	Interrupter cable badly connected			Change polarity of pilot cable	
	Interrupter cable disconnected or broken			Connect pilot cable	
Ignites from remote handset but not from touch pad	Touch control cable disconnected or broken			Connect or replace touch control cable	
	Defective touch control buttons			Change touch control	
Ignites from touch pad but not from remote	Bad communication with handset			Check batteries in handset	
				Check reception of signal from a shorter distance	
				Try pairing again	
				Try changing the channel in the configuration menu	
Switches off after 6 seconds	Short circuit in touch control	5 beeps	BUTTON ERROR	Change touch control wiring	
Low batteries on remote			Low battery	Change the batteries in the remote	
Appliance switches off		2 cycles of 3 beeps	CONFIG ERROR	Change control unit	
		2 cycles of 3 beeps	EEPROM ERROR	Try pairing again Change control unit	
	Loss of communication between appliance and remote for 18min	20 beeps		The remote is too far from the appliance Replace batteries in handset	
	High temperature on control unit	1 long beep	TEMP ERROR	If this occurs more than once call the technical service	
	Ambient temperature higher than configured		Over Temperature	Check the correct configuration of safety temperature	

Servicing Instructions - Replacing Parts

1. General

- 1.1 All main components can be replaced without removing the appliance from its installation.

IT IS ESSENTIAL THAT THE GAS SUPPLY TO THE APPLIANCE IS TURNED OFF AT THE ISOLATION DEVICE BEFORE PROCEEDING FURTHER.

- 1.2 **DISCONNECT BATTERIES BEFORE SERVICING THE APPLIANCE.**

Removal of Flue

- 1.3 **If, for any reason, the flue has to be removed from the appliance, the seal must be replaced in the inner spigot.**
- 1.4 Access to the controls is restricted and the whole control assembly must be removed as one unit (see Section 8 below).

2. Decorative Frame

The same method is used to remove each frame.

- 2.1 Lift the frame upwards off the four support brackets, see Diagram 1.

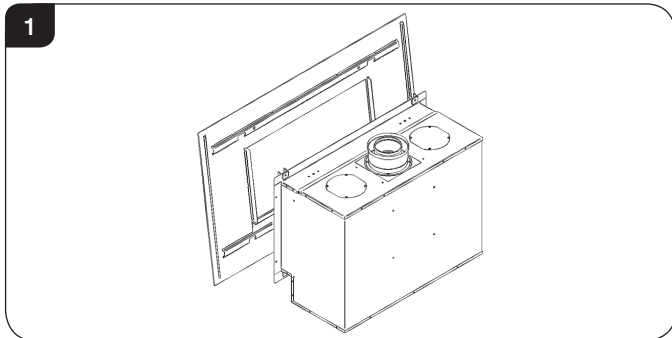

NOTE: THE STEEL FRAME IS HEAVY. TAKE CARE WHEN LIFTING.

3. Window Frame Assembly

- 3.1 To open the glass door use the hexagon key provided.
- 3.2 Release the window locks by moving them from shut to open towards the outer edges, see Diagram 2.

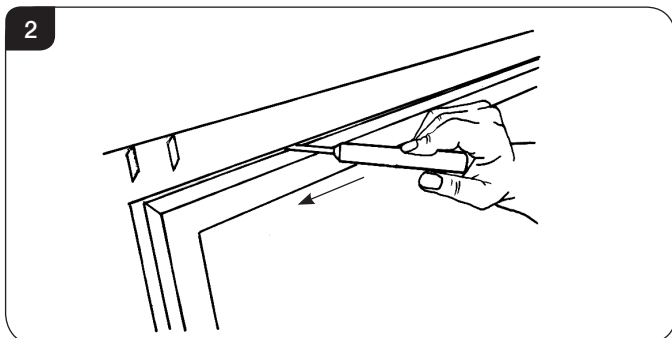

To completely remove the glass front:

- 3.3 Remove the securing spring clip from the bottom-right of the window frame, see Diagram 3.

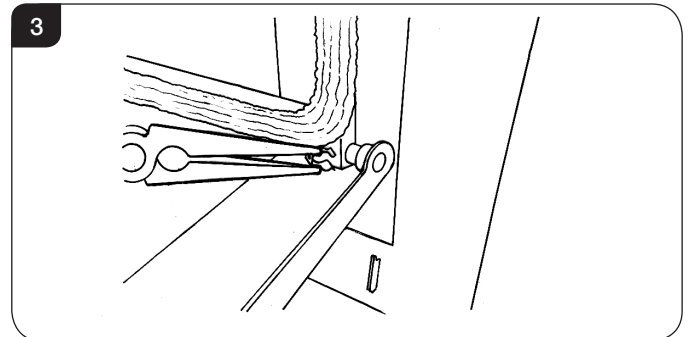

- 3.4 With the window frame in an upright position slide the frame to the left so that it comes off the left hinge pin.
- 3.5 Still keeping the frame upright drop the left side down and forward slightly, see Diagram 4.

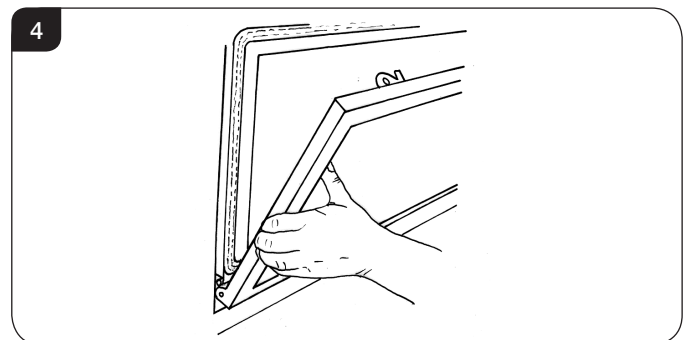

- 3.6 Slide the frame to the right so it comes off the right hinge pin. The window frame should now be free.
- 3.7 Refit in reverse order.
- 3.8 **When closing the door ensure the door catches are fully engaged.**



UNDER NO CIRCUMSTANCES SHOULD THE APPLIANCE BE USED WITHOUT THE CATCHES HOLDING THE DOOR IN PLACE.

4. Glass Window

- 4.1 Remove the two clips and brackets from either side of the frame (see Diagram 5).

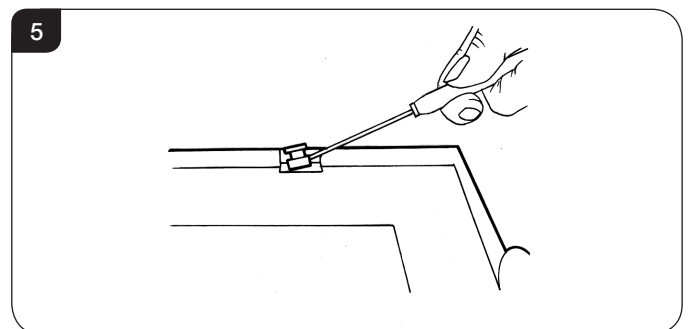

Servicing Instructions - Replacing Parts

- 4.2 Lift the glass clear from the lock bracket at the top of the frame and slide out.

5. Black Enamelled Panels for Studio with Stone Chippings

- 5.1 Slide the side panels forward until clear of the appliance, see Diagram 6.

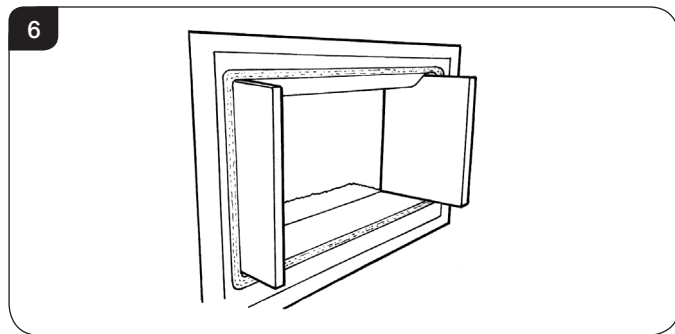

STUDIO 3 BF ONLY

To pull the bottom panel forward and out of the appliance:

- 5.2 Undo each screw on the left and right front of the burner tray, see Diagram 7.

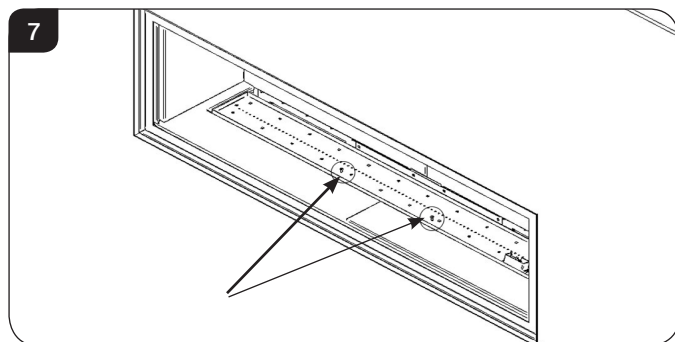

- 5.3 When removing the back panel first remove the main burner, see Section 7.
5.4 Slide the lower edge of the back panel forward and lift the panel from the appliance (see Diagram 8).

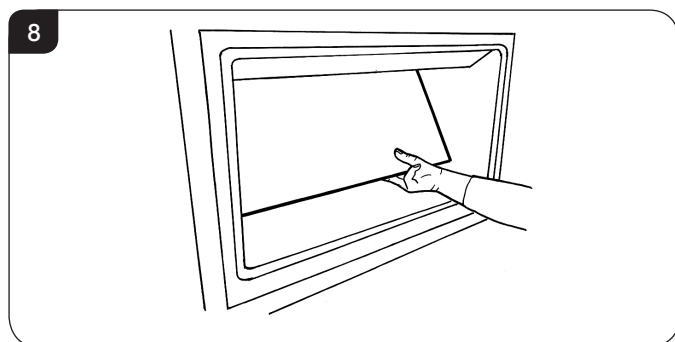

To reassemble the panels in reverse order:

- 5.6 Slide the top of the back panel into place before pushing the lower edge back.

- 5.7 Replace the main burner.
5.8 Replace the bottom panel.

6. Vermiculite/ Black Reeded Panels for Studio with Logs

- 6.1 The Studio appliances have the option of two different liner finishes:
Vermiculite
Black Reeded Panels

NOTE: ALL FRONT PANELS AND THE STUDIO 3 REAR PANELS ARE IN TWO PIECES.

STUDIO 1 & 2: HOLD THE REAR PANELS UNTIL ALL THE OTHER PANELS ARE IN PLACE AS THEY CAN FALL FORWARD.

STUDIO 3 HAS A TOP BRACKET TO SECURE THE PANELS THIS MUST BE REMOVED PRIOR TO ATTEMPTING TO FIT THE REAR PANELS.

- 6.2 Place the rear panel(s) behind the locating bracket on the rear support bar.
6.3 Centralise the rear panel(s) with the chamfers touching and pushed together, see Diagram 9.

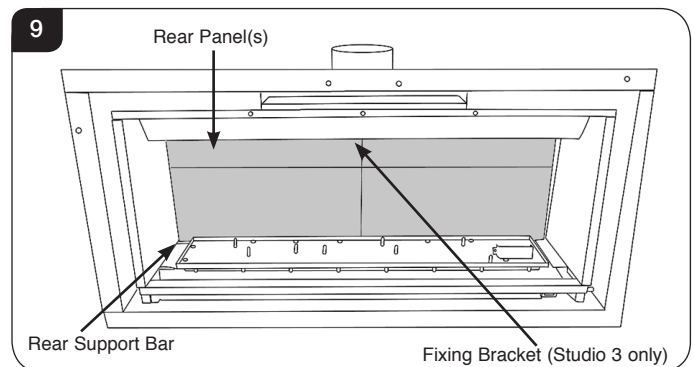

If installing the panels on a Studio 3 model replace the L shaped fixing bracket at the top rear of the firebox to hold the two rear liners in place.

- 6.4 Place the lower side and front panels in position so the chamfers meet at the front edge of the burner.
6.5 Ensure the two-piece front panels are engaged against the centre support tags on the burner and are pushed together in the middle, see Diagram 10.

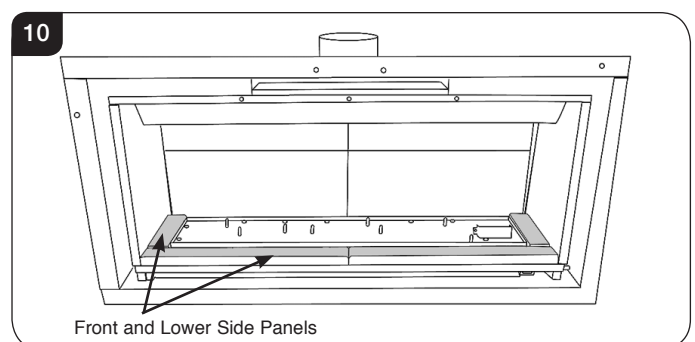

Servicing Instructions - Replacing Parts

- 6.6 Slide the two side panels up to the rear panel, see Diagram 11.

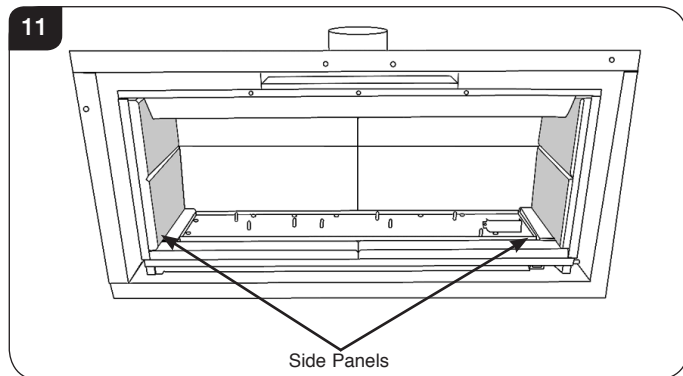

NOTE: THE HORIZONTAL CHAMFERS MUST ALIGN ON THE REAR AND SIDE PIECES.

- 6.6 Replace the side panels.

7. Main Burner

To replace the main burner:

- 7.1 Remove the stone chippings from the burner (optional).
7.2 Remove the black enamelled panels (see Section 5).
7.3 Remove the burner securing screw from the left side of the burner, see Diagram 12.

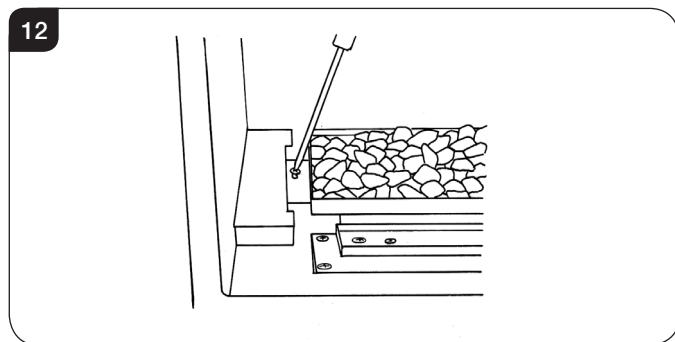

- 7.4 Slide the burner fully to the left and lift the right side clear of the pilot, see Diagram 13.

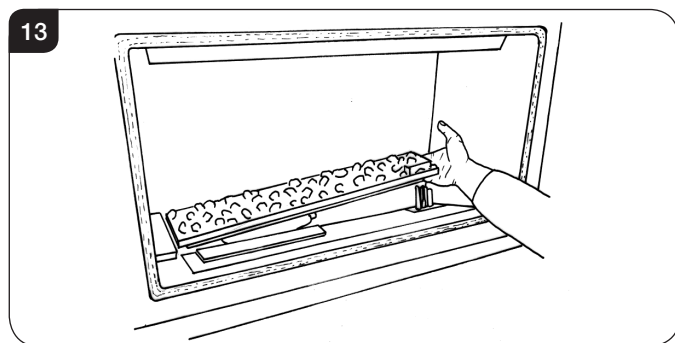

- 7.5 Slide the burner to the right and out of its location.

- 7.6 Refit in reverse order.

- 7.7 When refilling the stone chippings, fill to the level of the rim of the burner tray and flatten level.

Ensure no stone chippings fall into the pilot area.

8. Main Control Assembly

- 8.1 To access the main control assembly first remove:

- The decorative frame
- Window frame
- Enamelled panels
- Main burner

To remove the access panel:

- 8.2 Undo the two screws, see Diagram 14.
8.3 **Note the orientation of the access panel with the return edges facing forward.**

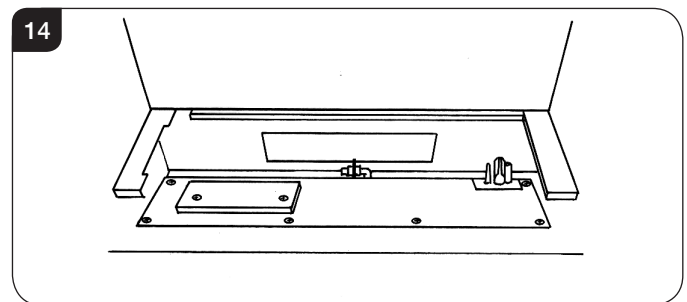

- 8.4 Isolate the gas supply at the isolation device and disconnect the gas inlet, see Diagram 15.

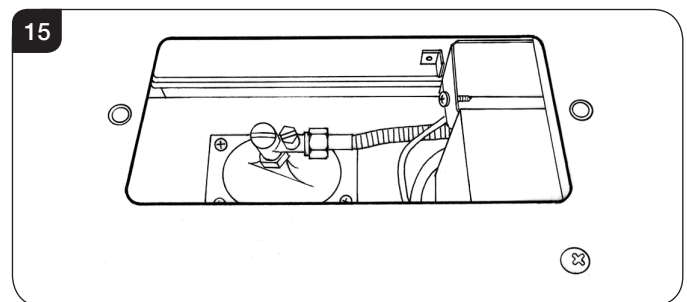

- 8.5 Remove the six screws securing the control assembly, see Diagram 16.

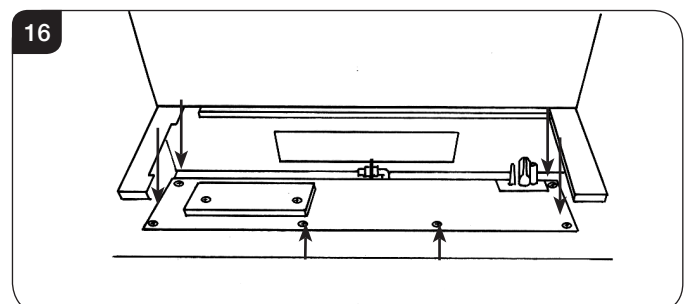

Servicing Instructions - Replacing Parts

- 8.6 The control panel can now be tilted back to reveal the controls, see Diagram 17.

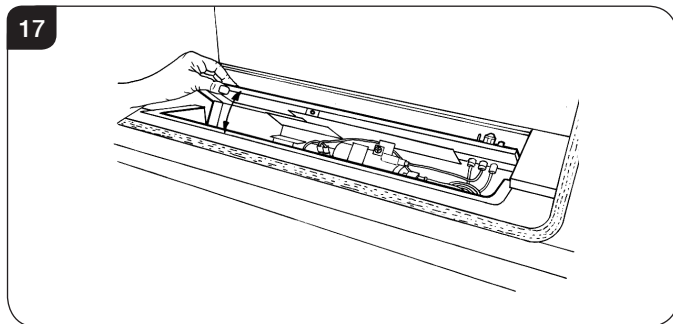

- 8.6 Disconnect the battery supply cable and the touch pad control cable from the control unit.

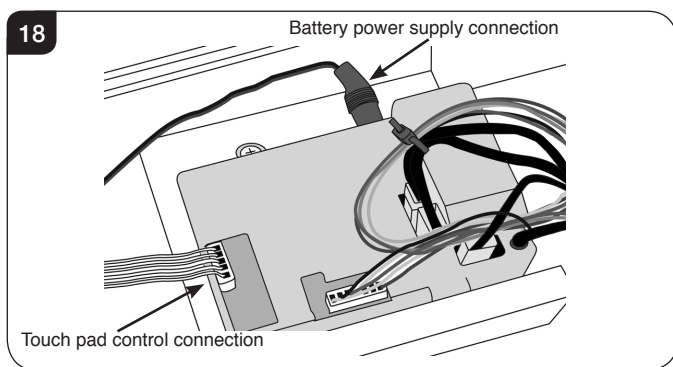

- 8.7 The control assembly can now be lifted up and removed.
8.8 Reassemble in reverse order.

9. Pilot Unit

The pilot assembly consists of four components, which can be individually changed, these are:

- 9a) Pilot burner bracket.
- 9b) Electrode
- 9c) Pilot Injector
- 9d) Thermocouple.

- 9.1 Before commencing work on the pilot the Main Control Assembly must be removed, see Section 8.

9a Pilot Burner Bracket

To remove the Pilot Burner Bracket:

- 9.2 **First remove the electrode, pilot pipe and thermocouple, see 9d and 9c.**
- 9.3 Remove the two screws securing the bracket. The pilot burner bracket can now be removed.
- 9.4 Check the pilot gasket and if damaged, replace with a new one.
- 9.5 Replace in reverse order.

9b Electrode

- 9.6 Pull the ignition lead off the electrode and undo the retaining nut, see Diagram 19.

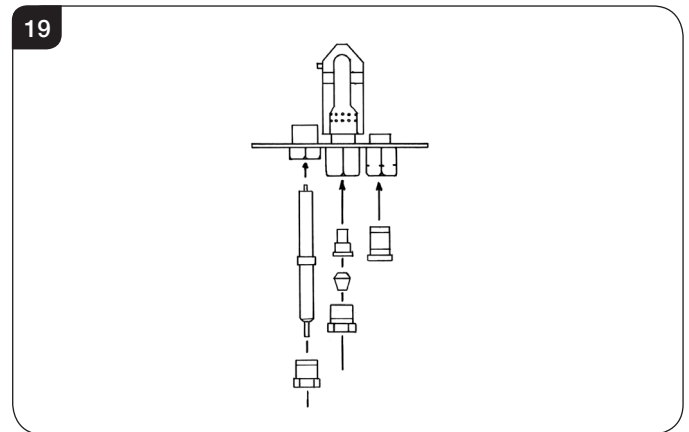

- 9.7 Replace with a new electrode. Do not over-tighten the nut; this could break the component.
9.8 Replace the ignition lead.

9c Pilot Injector

- 9.9 Undo the pilot pipe from the gas valve and from the underside of the pilot burner, see Diagram 20, Pilot Connection.

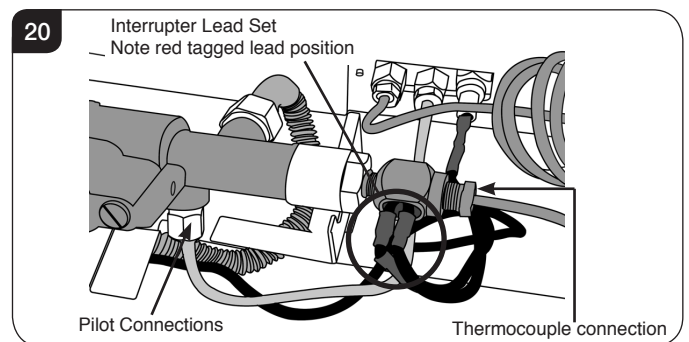

- 9.10 Remove the pipe and the injector drops out from the burner.

9d Thermocouple

- 9.11 Disconnect the thermocouple from the gas valve/interrupter, see Diagram 20.
- 9.12 Note the position of the interrupter leads. The lead with the red tag **MUST** be placed closest to the gas valve.
- 9.13 Undo the thermocouple nut in the back of the pilot bracket half a turn. This releases the thermocouple.
- 9.14 When replacing with a new thermocouple, take care to bend the new component to the same shape as the thermocouple just removed.

Servicing Instructions - Replacing Parts

- 9.15 To refit the thermocouple into the pilot bracket, ensure it is pushed fully into the hole. There is a stop on the thermocouple to set the height.
- 9.16 Lock the retaining nut just enough to grip the thermocouple.
- 9.17 Connect the thermocouple to the valve/interrupter **taking care not to over-tighten**.

10. Ignition Lead

To replace the ignition lead:

- 10.1 Release the Main Control Assembly and tilt backwards (see Section 8 above).
- 10.2 Remove the ignition lead from the control box, see Diagram 21.

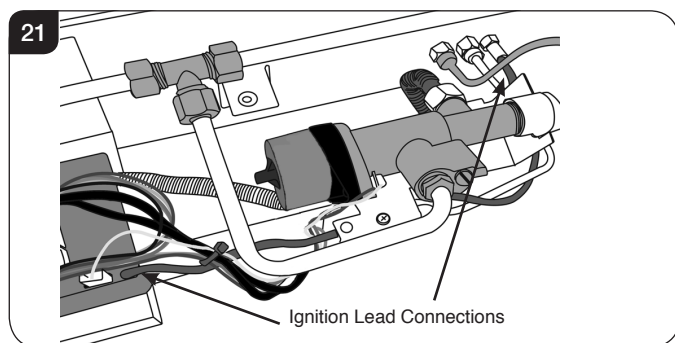

- 10.3 Remove the ignition lead from the electrode, see Diagram 21, removing cable ties where necessary.
- 10.4 **Note the direction of the lead. The new lead must follow exactly the same route. Replace cable ties where necessary.**

11. Gas Valve

To change the gas valve:

- 11.1 Remove the control assembly (see Section 8 above).
- 11.2 Release the gas inlet pipe, see Diagram 22.

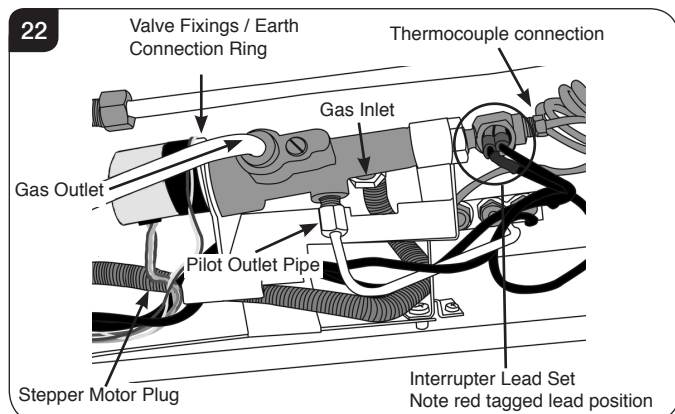

- 11.3 Remove the thermocouple from the interrupter block.
- 11.4 Release the pilot pipe, see Diagram 22.
- 11.5 Release the gas outlet pipe, see Diagram 22.
- 11.6 Remove the Stepper motor harness from the control box, see Diagram 21.
- 11.7 Remove the two nuts securing the valve to the support bracket and withdraw the valve.
- 11.8 Replace in reverse order.
- 11.9 Ensure that the earth cable ring tag is positioned between the valve body and the bracket.
- 11.10 Ensure the interrupter leads are connected correctly with the red tag lead nearest to the gas valve body.

12. Magnetic Safety Valve

To replace the magnetic safety valve:

- 12.1 Undo the thermocouple from the interrupter block and remove the two interrupter leads.
- 12.2 Unscrew the interrupter block from the back of the valve.
- 12.3 Undo the silver magnetic valve retaining nut on the back of the valve.
- 12.4 Gently tap out the mag valve.
- 12.5 Replace with a new unit.
- 12.6 Reassemble in reverse order ensuring that the interrupter leads are connected correctly with the red tag lead nearest to the gas valve body.

13. Control Box

- 13.1 Disconnect from the control box:

1. Ignition lead
2. Interrupter leads
3. Earth connection
4. 7-way stepper motor plug, see Diagram 23.

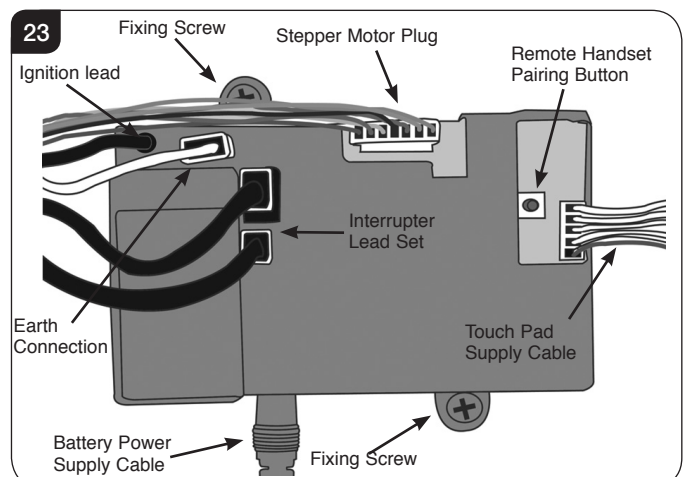

Servicing Instructions - Replacing Parts

13.2 Remove the battery extension cable, see Diagram 24.

13.3 Remove the touch pad extension cable.

The control box can now be replaced.

13.4 After replacing the control box ensure all connections are refitted, see Diagram 24.

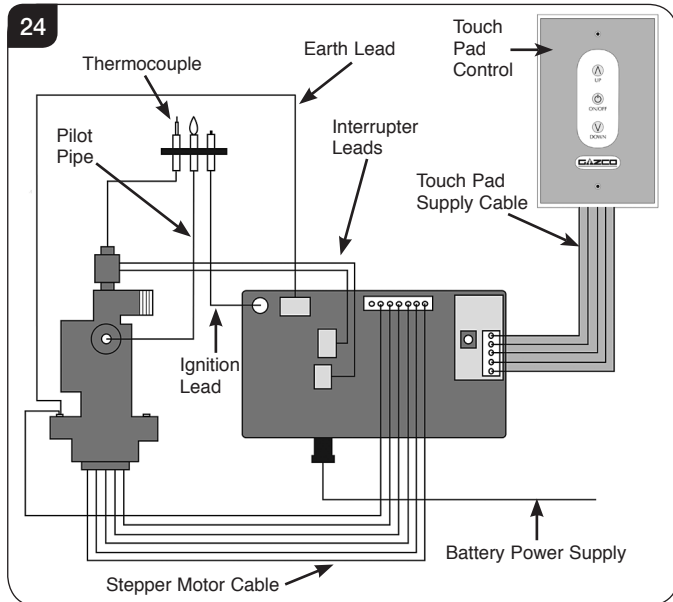

13.5 Prior to re-connection of the control box to the appliance, if there is no communication between the remote handset and the appliance, or if the handset is replaced, it will be necessary to pair the handset with the appliance. Please refer to Commissioning Section 2.

13.6 Ensure batteries are fitted and working in the handset.

13.7 Re-fit the touch pad control cable and the battery power supply cable to the control box.

14. Main Injector

To change the main injector:

14.1 Undo the injector fee pipe.

14.2 Undo the lock nut from the injector.

14.3 Replace with the correct size injector.

Note: For Studio 3 BF there are 2 main injectors.

15. Primary Aeration Plate

NOT ALL MODELS HAVE AERATION PLATES. REFER TO TECHNICAL SPECIFICATIONS, PAGES 16 & 17.

15.1 Remove the burner module as described in Servicing, Section 7.

15.2 Remove the fixing screw and slide the plate off the venturi.

15.3 Replace with the correct size plate and secure with the screw. Ensure the lower edge of the plate is located over the venturi flange, see Diagram 25.

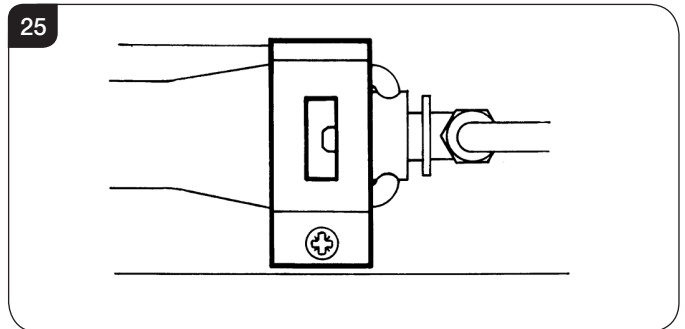

Studio 3 BF

The Studio 3 BF has two venturi. Ensure the correct aeration plates are fitted. Aeration plates can vary between left and right hand venturi, see Diagram 26.

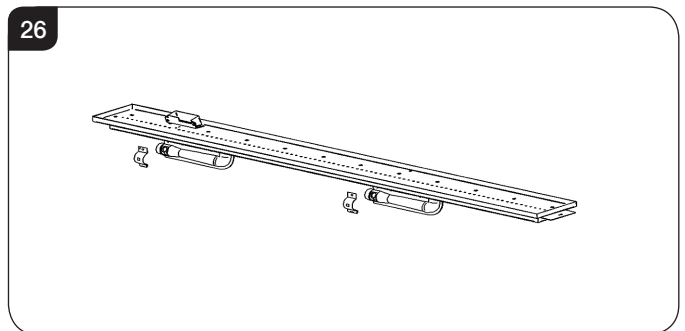

16. Changing Between Gas Types

In order to change between gas types it will be necessary to change both the burner assembly and the complete control assembly.

Contact your Gazco retailer for further information.

A kit of parts is available for this. Always quote the Model number and Serial number when ordering any spare parts.

17. Pressure and leak testing the appliance

17.1 To gain access to the pressure test point, see Diagram 27 follow Section 8, Main Control Assembly.

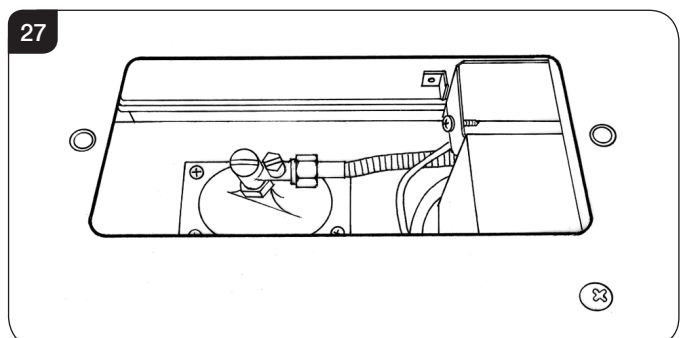

Servicing Instructions - Replacing Parts

- 17.2 To leak test any gas joints on the appliance the control assembly must be undone and tilted backwards, see Section 7.4, Diagram 13.
- 17.3 Because there is now no burner fitted to perform a leak test, place a manometer tube over the injector tip (it is necessary to block both injectors on Studio 3 models).
- 17.4 Light the appliance and spray any joints with leak detector fluid.
- 17.5 Tighten joints or replace as required.
- 17.6 To check the inlet working pressure, replace the control assembly and connect a manometer to the pressure test point, see Diagram 26.
- 17.7 Replace the burner and relight the appliance.
- 17.8 Operate the appliance at highest flame setting and check that the inlet pressure is in accordance with specifications detailed on pages 16 & 17.

Servicing Instructions - Replacing Parts

18. Short Spares List

STONE CHIPPINGS VERSIONS

COMPONENT	STUDIO 1 BF		STUDIO 2 BF		STUDIO 3 BF	
	NG	LPG	NG	LPG	NG	LPG
PILOT INJECTOR	PI0069	PI0070	PI0069	PI0070	PI0069	PI0070
MAIN INJECTOR	IN0007	IN0040	IN0005	IN0041	IN0039	IN0052
BURNER ASSEMBLY	GZ5983	GZ6363	GZ6417	GZ6418	GZ7081	GZ7082
AERATION PLATE	G20 - N/A	G31 - GZ2025	G20 - GZ2025	G31 - GZ2025	G20 2 x GZ3270	G31 2 x GZ3866
ELECTRODE	PI0075		PI0075		PI0075	
THERMOCOUPLE	PI0077		PI0077		PI0077	
MAG UNIT	GC0109		GC0109		GC0109	
IGNITION LEAD	GC0508		GC0508		GC0508	
GAS VALVE	GC0170	GC0172	GC0170	GC0172	GC0170	GC0172
CONTROL BOX	EL0575		EL0575		EL0575	
REMOTE CONTROL	EL0574		EL0574		EL0574	
INTERRUPTER BLOCK	GC0026		GC0026		GC0026	
INTERRUPTER LEADS	EL0499		EL0499		EL0499	
TOUCH PAD /WALL PLATE ASSEMBLY	EL0501		EL0501		EL0501	
TOUCH PAD LEAD	EL0502		EL0502		EL0502	
BATTERY HOLDER	EL0503		EL0503		EL0503	
BATTERY CABLE	EL0504		EL0504		EL0504	
REAR ENAMELLED PANEL	GZ6491		GZ6622		2 x GZ7290	
SIDE ENAMELLED PANEL	GZ6492		GZ6830		2 x GZ6830	
BASE ENAMELLED PANEL	GZ6493		GZ6623		LH GZ7288 / RH GZ7289	
STONE CHIPPINGS	CE1085		CE1088		CE1091	

Servicing Instructions - Replacing Parts

18. Short Spares List

LOG VERSIONS

COMPONENT	STUDIO 1 BF		STUDIO 2 BF		STUDIO 3 BF	
	NG	LPG	NG	LPG	NG	LPG
PILOT INJECTOR	PI0069	PI0070	PI0069	PI0070	PI0069	PI0070
MAIN INJECTOR	IN0007	IN0040	IN0005	IN0058	IN0061	IN0055
BURNER ASSEMBLY	GZ7456	GZ7457	GZ7545	GZ7436	GZ7521	GZ7452
AERATION PLATE	G20 - GZ3966	G31 - GZ3866	G20 - GZ3866	G31 - GZ3269	LH-GZ2016 RH-GZ3966	LH-GZ2025 RH-GZ2025
ELECTRODE	PI0075		PI0075		PI0075	
THERMOCOUPLE	PI0077		PI0077		PI0077	
MAG UNIT	GC0109		GC0109		GC0109	
IGNITION LEAD	GC0508		GC0508		GC0508	
GAS VALVE	GC0170	GC0172	GC0170	GC0172	GC0170	GC0172
CONTROL BOX	EL0575		EL0575		EL0575	
REMOTE CONTROL	EL0574		EL0574		EL0574	
INTERRUPTER BLOCK	GC0026		GC0026		GC0026	
INTERRUPTER LEADS	EL0499		EL0499		EL0499	
TOUCH PAD/WALL PLATE ASSEMBLY	EL0501		EL0501		EL0501	
TOUCH PAD LEAD	EL0502		EL0502		EL0502	
BATTERY HOLDER	EL0503		EL0503		EL0503	
BATTERY CABLE	EL0504		EL0504		EL0504	
VERMICULITE (LOOSE)	CE0745		CE0746		CE0747	
LOG SET	CE0696		CE0729		CE0739	
EMBAGLOW PACK	GZ8471					

LINERS

	STUDIO 1 BF		STUDIO 2 BF		STUDIO 3 BF	
	Vermiculite	Black Reeded	Vermiculite	Black Reeded	Vermiculite	Black Reeded
LINER BASE SIDE PIECE (2 PER APPLIANCE)	CE0673	CE1243	CE0673	CE1243	CE0673	CE1243
LINER BASE FRONT L/H PIECE	CE0677	CE1224	CE0689	CE1233	CE0736	CE1238
LINER BASE FRONT R/H PIECE	CE0706	CE1227	CE0707	CE1237	CE0737	CE1242
LINER BACK PANEL	CE0678	CE1225	N/A	N/A	N/A	N/A
LINER SIDE PANEL (2 PER APPLIANCE)	CE0679	CE1226	CE0679	CE1226	CE0679	CE1226
LINER BACK PANEL L/H SIDE	N/A	N/A	CE0690	CE1234	CE0738	CE1239
LINER BACK PANEL R/H SIDE	N/A	N/A	CE0727	CE1235	CE0735	CE1240

Service Records

1ST SERVICE

Date of Service:.....
Next Service Due:.....
Signed:.....
Retailer's Stamp/Gas Safe Registration Number

3RD SERVICE

Date of Service:.....
Next Service Due:.....
Signed:.....
Retailer's Stamp/Gas Safe Registration Number

5TH SERVICE

Date of Service:.....
Next Service Due:.....
Signed:.....
Retailer's Stamp/Gas Safe Registration Number

7TH SERVICE

Date of Service:.....
Next Service Due:.....
Signed:.....
Retailer's Stamp/Gas Safe Registration Number

9TH SERVICE

Date of Service:.....
Next Service Due:.....
Signed:.....
Retailer's Stamp/Gas Safe Registration Number

2ND SERVICE

Date of Service:.....
Next Service Due:.....
Signed:.....
Retailer's Stamp/Gas Safe Registration Number

4TH SERVICE

Date of Service:.....
Next Service Due:.....
Signed:.....
Retailer's Stamp/Gas Safe Registration Number

6TH SERVICE

Date of Service:.....
Next Service Due:.....
Signed:.....
Retailer's Stamp/Gas Safe Registration Number

8TH SERVICE

Date of Service:.....
Next Service Due:.....
Signed:.....
Retailer's Stamp/Gas Safe Registration Number

10TH SERVICE

Date of Service:.....
Next Service Due:.....
Signed:.....
Retailer's Stamp/Gas Safe Registration Number

Gazco Limited, Osprey Road, Sowton Industrial Estate, Exeter, Devon, England EX2 7JG
Technical Customer Services: (01392) 261950 Fax: (01392) 261951
E-mail: technicalservices@gazco.com

A member of the Stovax Group

E & O E