



# *Steel Manhattan Log Effect Stove Range Conventional Flue*

With upgradeable control valve

## **Instructions for Use, Installation and Servicing**

**For use in GB, IE (Great Britain and Eire)**

This appliance has been certified for use in countries other than those stated. To install this appliance in these countries, it is essential to obtain the translated instructions and in some cases the appliance will require modification. Contact Gazco for further information.

### **IMPORTANT**

**Do not attempt to burn rubbish in this fire. This stove must only be operated with the door secured firmly in position. The outer casing of this stove will become hot whilst in operation, it is therefore recommended that the appliance be guarded to protect the young and infirm using a suitable guard.**

**Ensure that fabrics such as curtains are not positioned above or near to the stoves outer casing.**

**Please read these Instructions carefully and keep them in a safe place.**

**They will be needed when servicing the fire.**

**The commissioning sheet found on page 3 of these instructions should be completed by the installer.**

**CONTENTS**  
**COVERING THE FOLLOWING MODELS**  
MANHATTAN – 8618LUC (AN/MA/BS) P8618LUC (AN/MA/BS)

	PAGE
<b>APPLIANCE COMMISSIONING CHECKLIST</b>	<b>3</b>
<b>USER INSTRUCTIONS</b>	<b>4</b>
<b>INSTALLATION INSTRUCTIONS</b>	<b>8</b>
Technical Specifications	8
Site Requirements	9
Installation	10
Commissioning	15
<b>SERVICING INSTRUCTIONS</b>	<b>15</b>
Servicing Requirements	15
Fault Finding	15
How to replace parts	17
Basic spare parts list	21
Service Record	22

# APPLIANCE COMMISSIONING CHECKLIST

## IMPORTANT NOTICE

Explain the operation of the appliance to the end user, hand the completed instructions to them for safe keeping, as the information will be required when making any guaranteed claims.

FLUE CHECK	PASS	FAIL
1. Flue is correct for appliance		
2. Flue flow test		
3. Spillage test		
GAS CHECK		
1. Gas soundness & let by test		
2. Standing pressure test	mb	
3. Appliance working pressure (on High Setting) NB All other gas appliances must be operating on full	mb	
4. Gas rate		
5. Does ventilation meet appliance requirements		
6. Have controls been upgraded (Upgradeable models only)	8455 Standard	YES NO
	8456 Programmable Time & Temperature	YES NO

<b>Dealer</b> ..... ..... .....  <b>Contact No.</b> .....  <b>Date of Purchase</b> .....  <b>Model No.</b> .....  <b>Serial No.</b> .....  <b>Gas Type</b> .....	<b>Installation Company</b> ..... ..... .....  <b>Engineer</b> .....  <b>Contact No.</b> .....  <b>Corgi Reg No.</b> .....  <b>Date of Installation</b> .....
--	---

This product is guaranteed for 2 years from the date of installation, as set out in the terms and conditions of sale between Gazco and your local Gazco dealer. **This guarantee will be invalid, to the extent permitted by law, if the above Appliance Commissioning Checklist is not fully completed by the installer and available for inspection by a Gazco engineer.** The guarantee will only be valid during the second year, to the extent permitted by law, if the annual service recommended in the Instructions for Use has been completed by a Corgi registered engineer, and a copy of the service visit report is available for inspection by a Gazco engineer.

# USER INSTRUCTIONS

## 1. GENERAL

- 1.1 Installation and servicing must be carried out by a competent person in accordance with Gas Safety (Installation and Use) Regulations 1998, the relevant British Standards for Installation, appropriate Codes of Practice and in accordance with the manufacturer's instructions. It is recommended that a CORGI registered engineer be used for this purpose as they are approved by the HSE under the above regulations.
- 1.2 This appliance is suitable for use in G.B. and I.E. using Natural Gas at a supply pressure of 20mbar or LPG at a supply pressure of 29mbar (Butane) or 37mbar (Propane).
- 1.3 The installation shall also be completed in accordance with: The Building Regulations issued by The Department of The Environment.  
The Building Standards (Scotland) Regulations issued by the Scottish Development Department. For Republic of Ireland, reference should be made to the relevant standards governing installations (IS813:1996)
- 1.4 Read all these Instructions before commencing installation.
- 1.5 This appliance must be installed in accordance with the rules in force and only used in a sufficiently ventilated space.
- 1.6 Ensure that curtains are not positioned above the stove, and that there is at least a clearance of 300mm between the sides of the stove and any curtains.
- 1.7 The manufacturer considers the full outer casing of this stove to be a working surface. Therefore it will become hot whilst in operation. A suitable guard is recommended to protect young children, the aged and the infirm.
- 1.8 This stove must only be operated with the door secured firmly in position. If any cracks appear in the glass the appliance must not be used until the glass panel is replaced.
- 1.9 Do not attempt to burn rubbish in this stove.
- 1.10 Any combustible shelves or surrounding furniture must only be fitted in accordance with the minimum dimensions detailed in Diagram 1.

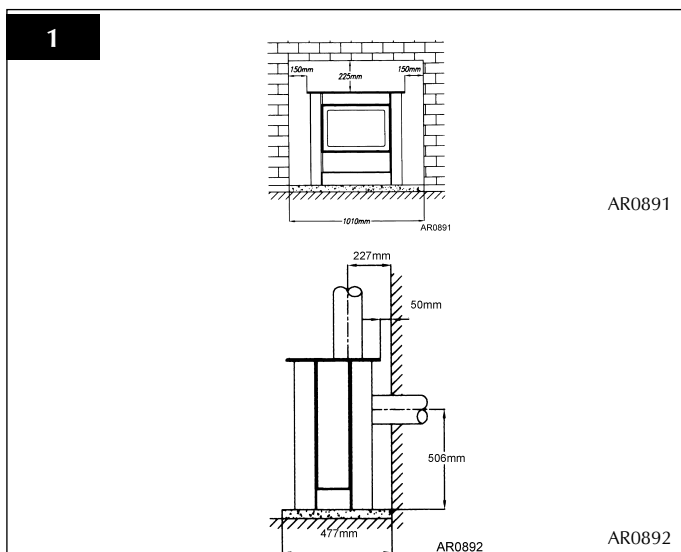

- 1.11 Contact a competent service engineer to carry out relevant spillage checks etc. following home improvements carried out after installation of this stove (e.g. the fitting of double glazing).

- 1.12 In all correspondence, please quote the appliance type and Serial Number which can be found on the databadge at the rear of the stove.
- 1.13 This product is guaranteed for 2 years from the date of installation, as set out in the terms and conditions of sale between Gazco and your local Gazco dealer. Please consult with your local Gazco dealer if you have any questions. In all correspondence always quote the Model No. and Serial No. Please ensure the commissioning checklist is completed by your installer, as this is a requirement of your Guarantee.

## 2. LIGHTING THE STOVE

- 2.1 Locate the control valve on the appliance. There are two control knobs on the valve, the right-hand knob controls the pilot ignition and the left-hand knob controls the main burner.
- 2.2 If your appliance has already been upgraded to battery remote control, please refer to the instructions provided with the upgrade to operate the remote control. The following instructions will work for either situation.

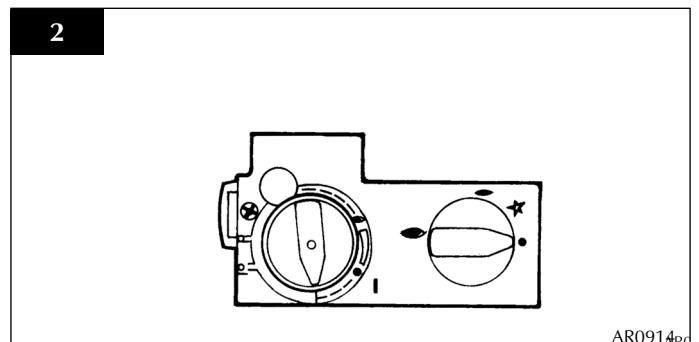

- 2.3 Ensure that the left-hand control knob is pointing to off (●)
- 2.4 Ensure that the right-hand control knob is pointing to off (●).
- 2.5 Press in the right-hand control knob and rotate it anticlockwise until a click is heard (keep pressing in) and the knob is pointing to pilot (☛). The pilot should now light. If the pilot has not lit, repeat the procedure until it does.
- 2.6 Keep the control knob pressed in for 10 seconds and then release it, the pilot should stay alight. If the pilot goes out, repeat the procedure until it does.
- 2.7 If the pilot will not light after repeated attempts, contact the retailer or installer from whom the appliance was purchased.
- 2.8 Turn the right-hand control knob to point to main burner (☛). The appliance can now be controlled using the left-hand control knob.
- 2.9 Turn the left-hand control knob to point to low fire (☛) the main burner will light on low. The burner can now be controlled between low and high settings. Turn the control knob anti-clockwise to increase the flame height and clockwise to decrease the flame height.

**THE YELLOW FLAMES WILL APPEAR WHEN THE FIRE HAS GAINED SUFFICIENT HEAT - TYPICALLY 10 TO 20 MINUTES.**

**IF THE APPLIANCE IS EXTINGUISHED OR GOES OUT IN USE, WAIT 3 MINUTES BEFORE ATTEMPTING TO RELIGHT THE APPLIANCE.**

# USER INSTRUCTIONS

## 3. TURNING OFF THE STOVE

- 3.1 To turn the stove off, locate the control valve, turn the left-hand control knob until it points to off (●). The main burner will go out leaving the pilot burning.
- 3.2 To turn the pilot off, locate the control valve, turn the right-hand control knob until it points to off (●), the pilot will go out.

## 4. UPGRADING YOUR STOVE

- 4.1 Your stove is fitted with a control valve that can be easily upgraded to battery powered remote control. This upgrade can be fitted by anyone capable of simple DIY jobs and requires no special training. There are two versions of this control which can be obtained through your local Gazco stockist.
- 4.2 **STANDARD REMOTE CONTROL** This remote control can control the gas appliance after the pilot has been lit. It can turn the main burner on and regulate it from low through to high and back again. It can turn the main burner off leaving the pilot burning. GAZCO PART NUMBER 8455.
- 4.3 **THERMOSTATIC AND TIMER REMOTE CONTROL** This remote control can control the gas appliance after the pilot has been lit. In 'MANUAL MODE' it can be used to turn the main burner on and manually regulate it from low through to high and back again. It can also be used to turn the main burner off leaving the pilot burning. In 'AUTO MODE' it will automatically regulate the room temperature. In 'TIMER MODE' it will turn the fire on and off according to a pre-set programme and automatically regulate the room temperature during two ON periods. GAZCO PART NUMBER 8456.

## 5. HANDLING & DISPOSAL OF FIRE CERAMICS

The fuel effect and side panels in this appliance are made from Refractory Ceramic Fibre (RCF), a material which is commonly used for this application.

Protective clothing is not required when handling these articles, but we recommend you follow normal hygiene rules of not smoking, eating or drinking in the work area and always wash your hands before eating or drinking.

To ensure that the release of RCF fibres are kept to a minimum, during installation and servicing a HEPA filtered vacuum is recommended to remove any dust accumulated in and around the appliance before and after working on it. When servicing the appliance it is recommended that the replaced items are not broken up, but are sealed within heavy duty polythene bags and labelled as RCF waste.

RCF waste is classed as stable, non-reactive hazardous waste and may be disposed of at a licensed landfill site.

Excessive exposure to these materials may cause temporary irritation to eyes, skin and respiratory tract; wash hands thoroughly after handling the material.

## 6. CLEANING THE FIRE

**WARNING: DO NOT ATTEMPT TO CLEAN THE STOVE UNTIL IN A COLD CONDITION. THE STOVE RETAINS ITS HEAT FOR A CONSIDERABLE TIME AFTER SHUTDOWN.**

- 6.1 Remove the glass door and decorative steel trim.
- 6.2 Carefully remove the ceramic fuel bed components and place to one side taking care to protect floor coverings etc. PLEASE HANDLE WITH CARE.
- 6.3 The logs should not require cleaning. Do not use a vacuum cleaner or brush to clean the logs. Any large pieces of debris may be removed by hand.
- 6.4 Ensure any debris is removed from the burner ports.
- 6.5 Replace the ceramics and door referring to Section 7 below.
- 6.7 Use a damp cloth to clean the outer casing of the appliance.

## 7. FUEL BED ARRANGEMENTS

To gain access to the ceramic fuel pieces, it will be necessary to remove the glass door. Lift off the decorative steel trim, see diagram 3 and remove the 8 screws holding the glass frame. See diagram 4.

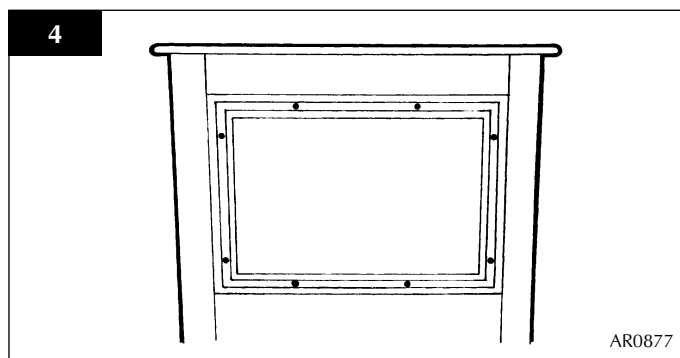
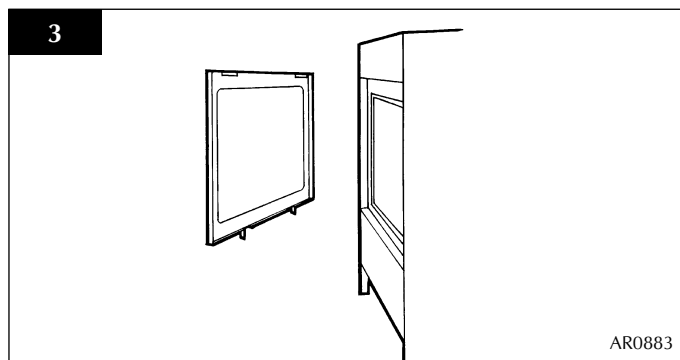

# USER INSTRUCTIONS

- 7.1 Take the rear log A and place it up against the rear of the fire sitting on the two flat ledges of the burner. The two legs of the log should sit between the rear burner ports. See diagram 5. Ensure there is an equal gap between each side of the log and the side of the firebox.

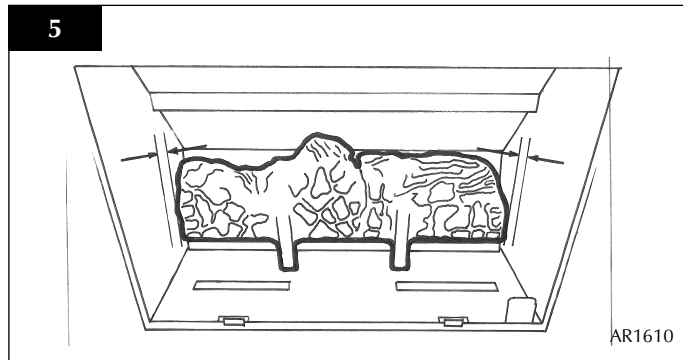

- 7.2 Place log B on the left-hand side of the burner with the location bar on the underside of the log fully located in the long slot of the burner. Make sure the log is as far to the left as possible. See diagram 6.

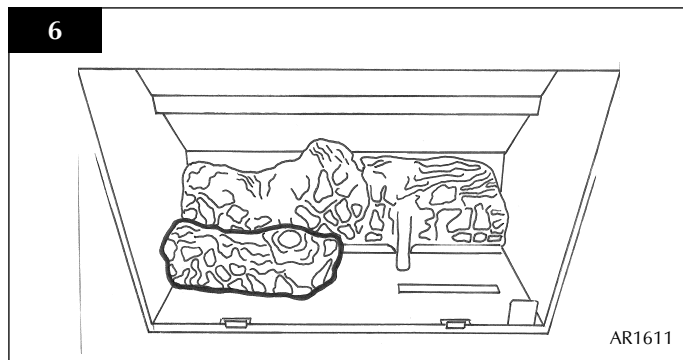

- 7.3 Place log C on the right-hand side of the burner with the location bar on the underside of the log fully located in the long slot in the burner. Make sure the log is as far right as possible. See diagram 7.

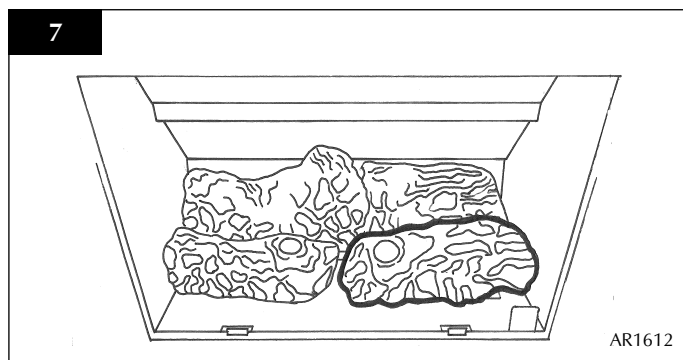

- 7.4 Place log D across from the rear log A to log B on the left-hand side. There are cut-outs in both logs for location. See diagram 8.

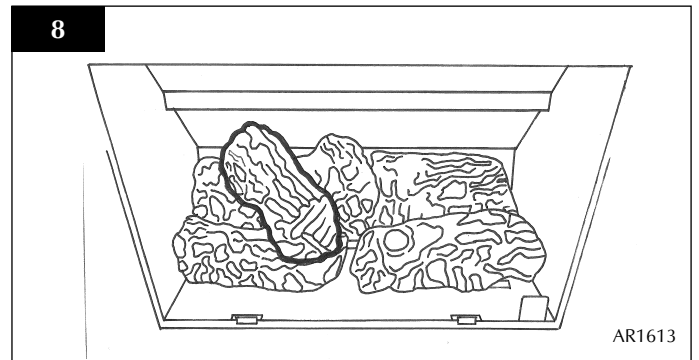

- 7.5 There are two ash panels which lay across the front of the burner skin. Place the panel with the flat edge facing the left side of the firebox. There are location holes on this log which fit over the screw holes of the burner skin.

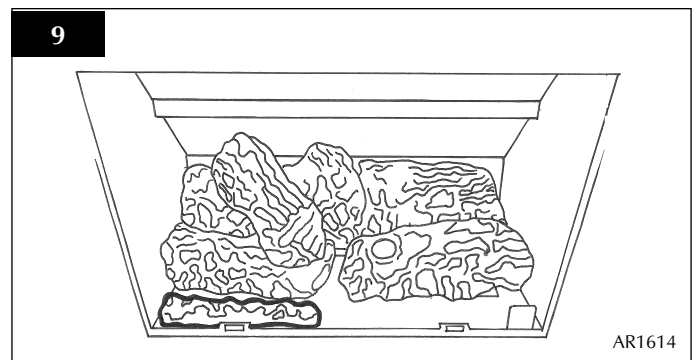

- 7.6 Place the second ash panel to the right of the first, with the pointed end of the panel fitting into the V shape. This panel should locate on the screw holes of the burner skin. Ensure that both logs are horizontal to the burner ports.

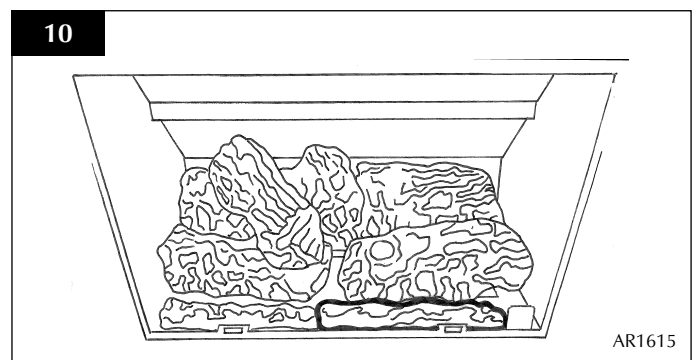

- 7.7 Place log E across from the rear of log A to log C on the right-hand side. Again, there are cut-outs for location. The front of the log should sit on the front ash panels and should fit tight to log C. See diagram 11.

# USER INSTRUCTIONS

11

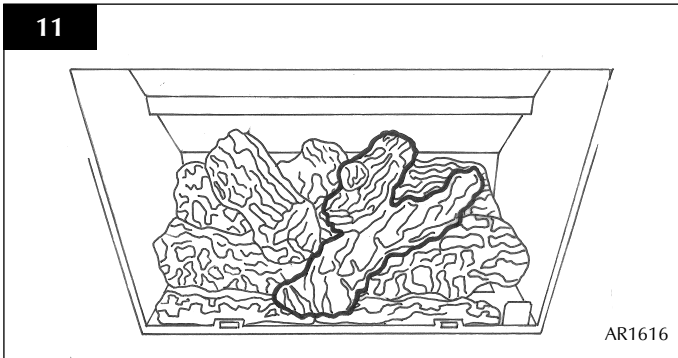

- 7.8 Carefully insert the front coal retainer into the front panel of the firebox. Take care not to scrape/damage the logs. This coal retainer sits in two brackets. Ensure it is fully inserted, leaving approximately a 4 mm gap between the firebox ledge and the bottom of the coal retainer.

12

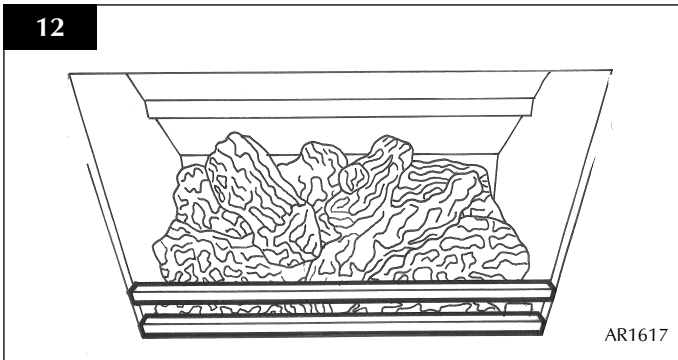

- 7.9 Ensure that the rope seal on the back of the glass frame is intact. Replace the glass frame making sure that the 8 screws are tightened evenly. Do not overtighten. See diagram 13.

13

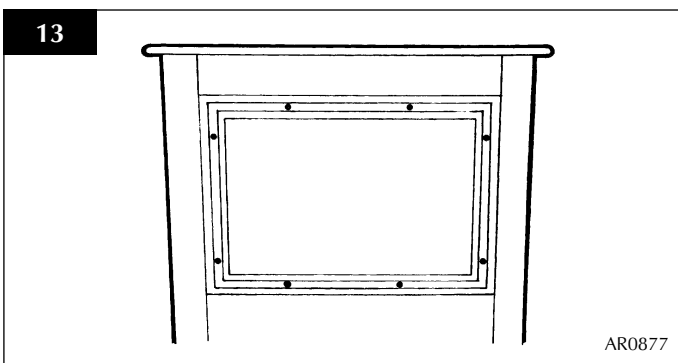

**NEVER OPERATE THE STOVE WHEN THE DOOR IS REMOVED.**

## 8. GAZCO FLUE SURE SYSTEM

- 8.1 The stove is fitted with the Gazco Flue Sure System, which will act to cut off the gas supply to the burners in the event of incorrect operation of the flue. If the system acts to cut off the gas supply, this indicates that there is insufficient flue pull. If this occurs a minimum of 10 minutes should be allowed before trying to relight. Continued operation of this safety device means there may be a serious problem with

the flue system. A qualified gas engineer should inspect this. **DO NOT USE THE STOVE UNTIL AN ENGINEER SAYS IT IS SAFE TO DO SO.**

## 9. THE FLAME FAILURE DEVICE

- 9.1 This is a safety feature incorporated in all GAZCO fires which automatically switches off the gas supply if the pilot light goes out and fails to heat the thermocouple.

## 10. 'RUNNING IN'

- 10.1 The surface coating on your GAZCO fires will "burn off" during the first 24 hours of use, producing a harmless and temporary odour. This will disappear after the short period of use. If the odour persists, ask your retailer for advice.

## 11. SERVICING

- 11.1 A qualified gas engineer must service the stove every 12 months. In all correspondence, always quote the appliance type and the Serial Number that may be found on the databadge on the appliance.

## 12. VENTILATION

- 12.1 Any purpose provided ventilation should be checked periodically to ensure that it is free from obstruction.

## 13. INSTALLATION DETAILS

- 13.1 To assist in any future correspondence, your installer should have completed the commissioning sheet at the front of this manual. This records the essential installation details of this appliance. In all correspondence always quote the Model No. and Serial No.

## 14. HOT SURFACES

- 14.1 The manufacturer consider the full outer casing of this stove to be a working surface. Therefore it will become hot whilst in operation. A suitable guard is recommended to protect young children, the aged and the infirm.

# INSTALLATION INSTRUCTIONS

## TECHNICAL SPECIFICATION

COVERING THE FOLLOWING MODELS:

STEEL MANHATTAN 8618LUC (AN/MA/BS) – P8618LUC (AN/MA/BS)

Model	Gas CAT.	Gas Type	Working Pressure	NOX Class	Aeration	Injector	Gas Rate m <sup>3</sup> /h	Input kW (Gross)		Country
								High	Low	
8618LUC	I <sub>2H</sub>	Natural (G20)	20 mbar	3	Ø 14.5	375	0.623	6.6 Gross	3.6 Gross	GB, IE
P8618LUC	I <sub>3P</sub>	Propane (G31)	37 mbar	3	Ø 11.5 x 2	165	0.232	6.4 Gross	3.6 Gross	GB, IE

Efficiency Class II

Flue Outlet Size 127mm (5") Ø

Gas Inlet Connection Size 8mm Ø

Minimum Flue Specification T260 / N2 / 0 / D / 1

Maximum Flue Temperature 180°C

### Packing Checklist

#### Qty Description

- 1 Stove
- 1 Flue Blanking plate
- 1 Coal Retainer
- 1 Log set (5 logs)\*
- 1 Ash Panel (2 sections)\*
- 1 Fixing Kit Containing
  - 1 Instruction Manual
  - 1 Wood Screw
  - 1 Rawplug
  - 1 Box spanner

\*Packed in appliance

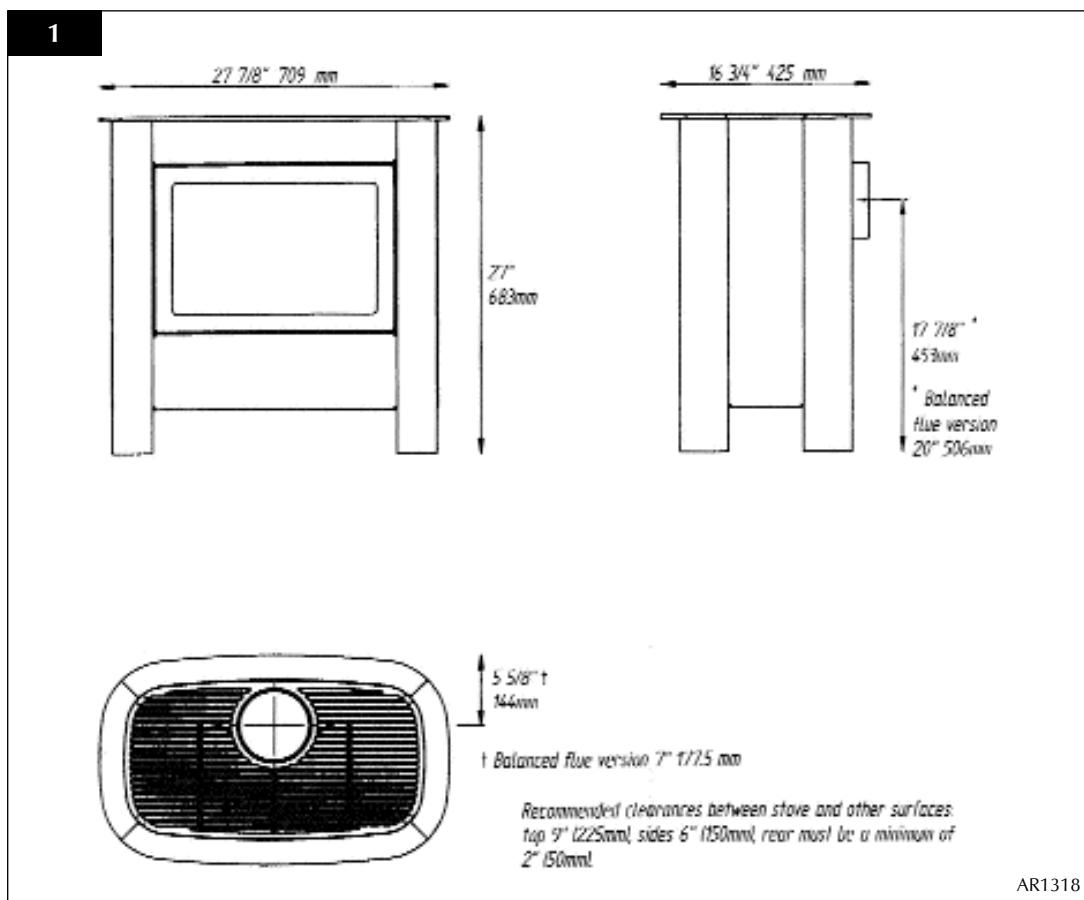



# INSTALLATION INSTRUCTIONS

## 1. FLUE AND CHIMNEY REQUIREMENTS

- 1.1 The chimney or flue system must comply with the rules in force and must be a minimum of 127mm in diameter. (5").
- 1.2 The minimum effect height of the flue or chimney must be 3 metres (10ft). Any horizontal flue run from the rear outlet should not exceed 100mm from the back of the appliance.
- 1.3 The chimney or flue must be free from any obstruction. Any damper plates should be removed or secured in the fully open position and no restrictor plates should be fitted.
- 1.4 The chimney should be swept prior to the installation of the appliance. However, where it can be seen that the chimney is clean and unobstructed throughout its entire length, it need not be swept.

NOTE: If it is intended to fit the stove into a existing brick built chimney without a closure plate, a 5" (127mm) liner must be used. Larger lined flues may work, but in some instances could cause cold start flue problems resulting in nuisance shutdown. Lined flues above 7" (175mm) are not recommended.

Due to recent changes to European chimney standards, new flues and chimneys are now described by their temperature, pressure and resistance to corrosion, condensation and fire. To assist in identifying the correct flue system, the minimum flue specification is shown in the technical specification of this book. Existing chimneys are not covered by this system.

## 2. VENTILATION

- 2.1 Consult the rules in force.

Note: This appliance does not normally require any additional ventilation when installed in G.B.

## 3. INSTALLATION OF THE GAS SUPPLY

- 3.1 Before installation, ensure that the local distribution conditions (identification of the type of gas and pressure) and the adjustment of the appliance are compatible.
- 3.2 Ensure that the gas supply is capable of delivering the required amount of gas and is in accordance with the rules in force.
- 3.3 Soft copper tubing and soft soldered joints can be used but must not be closer than 50mm to the base of the tray.
- 3.4 A means of isolating the gas supply to the appliance must be provided independent of any appliance control.
- 3.5 All supply gas pipes must be purged of any debris that may have entered prior to connection to the appliance.

## 4. APPLIANCE LOCATION

- 4.1 This appliance must stand on a non-combustible hearth that is at least 12mm thick. The minimum dimensions are shown in diagram 1.

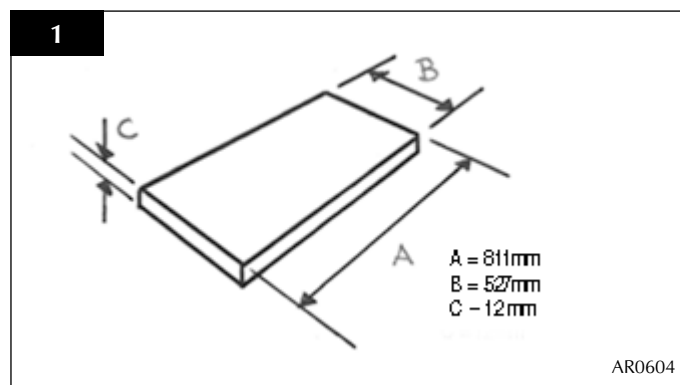

- 4.2 This appliance must not be installed in a room that contains a bath or shower.
- 4.3 This stove is not suitable for installation against a combustible wall; all combustible materials must be removed from the area behind the stove.
- 4.4 Ensure that all minimum clearances to combustible materials are complied with. See diagram 2.

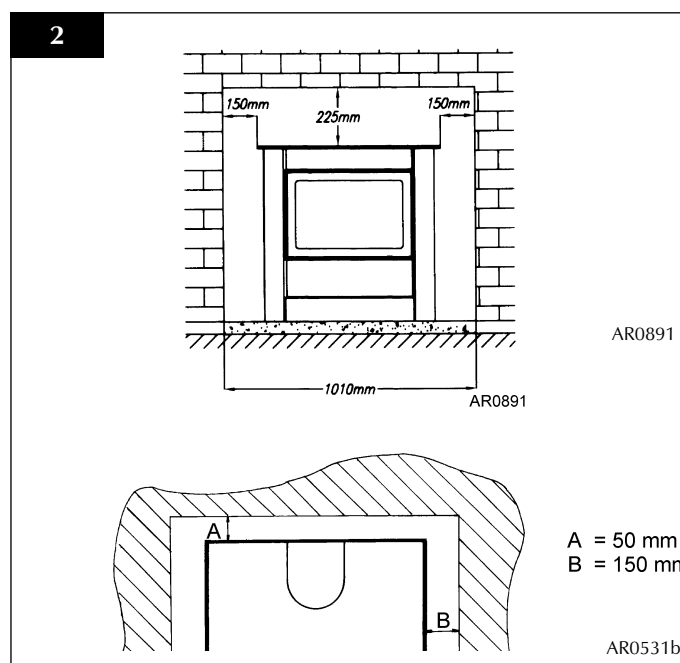

**NOTE: IN A NON-COMBUSTIBLE RECESS ATTENTION MUST BE GIVEN TO ALLOWING ADEQUATE CLEARANCE AT THE SIDES AND REAR OF THE STOVE, SO THAT A SPILLAGE TEST CAN BE PERFORMED AND THE CONTROLS REACHED.**

# INSTALLATION INSTRUCTIONS

## INSTALLATION

**IMPORTANT: ENSURE THAT THE APPLIANCE IS CORRECTLY ADJUSTED FOR THE GAS TYPE AND CATEGORY APPLICABLE IN THE COUNTRY OF USE. REFER TO DATABADGE AND TECHNICAL SPECIFICATIONS OF THIS BOOKLET. FOR DETAILS OF CHANGING BETWEEN GAS TYPES REFER TO SECTION 11, REPLACING PARTS.**

### 1. CONTROL UPGRADE

- 1.1 This stove is fitted with a control valve that can be easily upgraded to battery powered remote control. There are two versions of this control which can be obtained through your local Gazco stockist.
- 1.2 This upgrade can be fitted before or after installation but if side clearances are limited then it will be easier to upgrade the stove before installation. Full instructions are included with the kit.
- 1.3 **STANDARD REMOTE CONTROL**  
This remote control can control the gas appliance after the pilot has been lit. It can turn the main burner on and regulate it from low through to high and back again. It can turn the main burner off leaving the pilot burning. GAZCO PART NUMBER 8455.
- 1.4 **THERMOSTATIC AND TIMER REMOTE CONTROL**  
This remote control can control the gas appliance after the pilot has been lit. In "MANUAL MODE" it can be used to turn the main burner on and manually regulate it from low through to high and back again. It can also be used to turn the main burner off leaving the pilot burning. In "AUTO MODE" it will automatically regulate the room temperature. In "TIMER MODE" it will turn the fire on and off according to a pre-set programme and automatically regulate the room temperature during two on periods. GAZCO PART NUMBER 8456.

### 2. SAFETY PRECAUTIONS

- 2.1 This appliance must be installed in accordance with the rules in force, and used only in a sufficiently ventilated space. Please read these instructions before installation and use of this appliance.
- 2.2 All the instructions must be left intact with the user.
- 2.3 In your own interests and those of safety, this appliance must be installed by a competent person in accordance with local and national codes of practice. Failure to install the appliance correctly could lead to prosecution.
- 2.4 This appliance is intended for use on a governed gas installation and set to the required pressure.
- 2.5 Keep all plastic bags away from young children.
- 2.6 Do not place any object on or near to the stove. Allow adequate clearance above the stove. See diagram 2 Site Requirements, Appliance Location.
- 2.7 The stove is fitted with the Gazco Flue Sure System, which will act to cut off the gas supply to the appliance in the event of incorrect operation of the flue. If the system acts to shut off the gas supply, this indicates that there is insufficient flue pull. If this occurs a minimum of 10 minutes should be

allowed before trying to relight. Continued operation of this safety device means that there may be a serious problem with the flue system; a qualified gas engineer should inspect this. **DO NOT USE THE STOVE UNTIL AN ENGINEER SAYS IT IS SAFE TO DO SO.**

- 2.8 The Flue Sure System must not be tampered with. Use only genuine Gazco replacement parts when servicing the system - refer to Servicing section, Replacing Parts.

### 3. INSTALLATION OF THE STOVE

#### FLUE PIPE INSTALLATION

- 3.1 Open the carton and remove accessory carton and stove unit. It will now be necessary to decide upon top or rear flue exit, the stove is factory built for rear flue exit, but it may be changed to top exit by using the following method.
  - 3.1.1 Remove the flue spigot from the rear of the stove and replace with the blanking plate from the top of the stove and vice versa.
  - 3.2 When installing with a top flue please note the flue pipe fits through a hole in the top grill, the dimensions are for floor fixing a top flue installation with clearance for side panels.
  - 3.3 Position the engine assembly in its intended location and mark the position of the two floor fixing holes at the base of each side of the subframe, minimum fixing dimensions to a rear wall are shown in diagram 1.
  - 3.4 Remove the stove and drill the holes using a number 12 masonry drill. Push rawlplugs into the holes and insert the woodscrews until the head is approximately 3mm proud of the hearth. Place the stove in position over the bracket so that the screw heads locate in the large part of the slot. Push the stove back so that the screw heads engage fully into the narrow part of the slot, tighten the screws if desired.

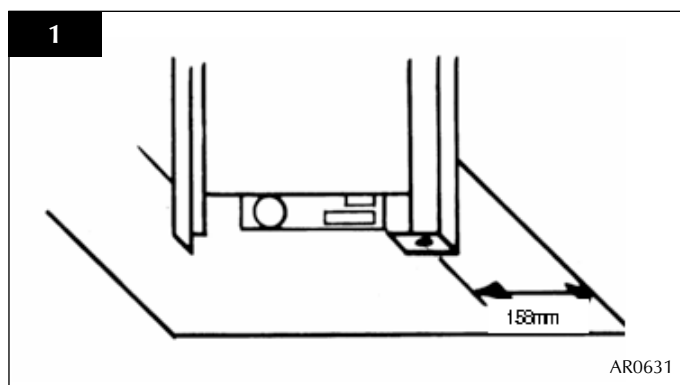

# INSTALLATION INSTRUCTIONS

## INSTALLATION

- 3.5 Having run the gas supply to the stove, PURGE THE SUPPLY PIPE, this is essential to expel any debris that may block the gas controls. Connect the gas supply to the 8mm compression elbow at the right-hand rear corner of the stove. There is a cutout in the right-hand rear leg to enable a direct straight connection to be made to the rear of the stove. See diagram 2. A gas soundness check must be completed up to the gas inlet connection.

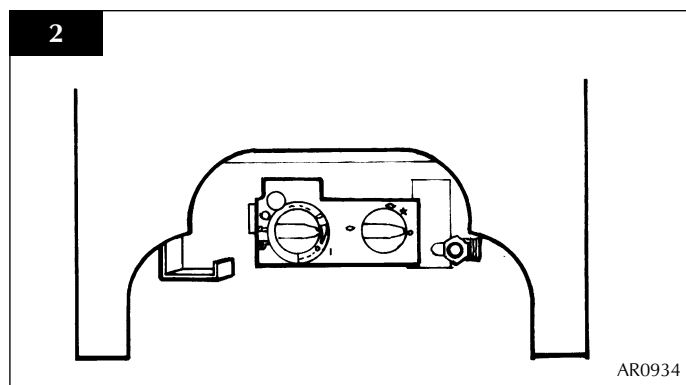

- 3.6 Open the second carton and carefully remove the steel casing components. Remove the protective plastic coating from the two side assemblies. Attach the four lugs to the front side of each panel and lower them onto the engine assembly until the tabs locate as shown. Check that the feet are touching the hearth. See Diagram 3.

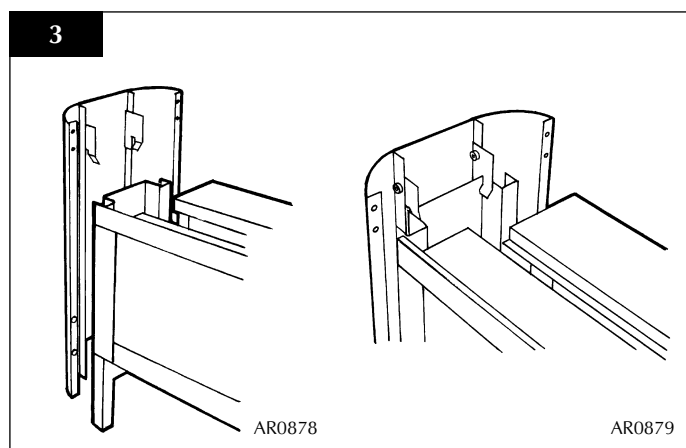

- 3.7 Secure the upper front panel using the 4 nuts and bolts provided. See diagram 4.

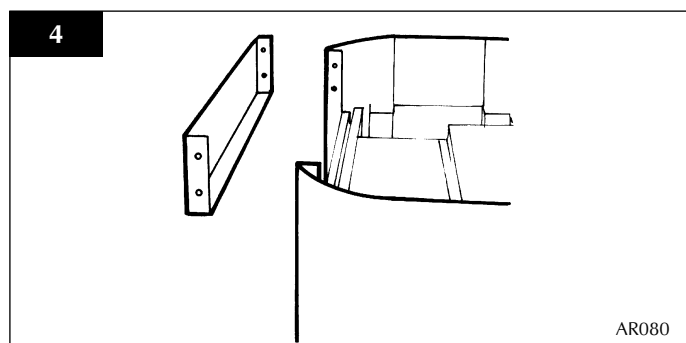

- 3.8 Locate the lower panels onto the lugs as shown. See diagram 5.

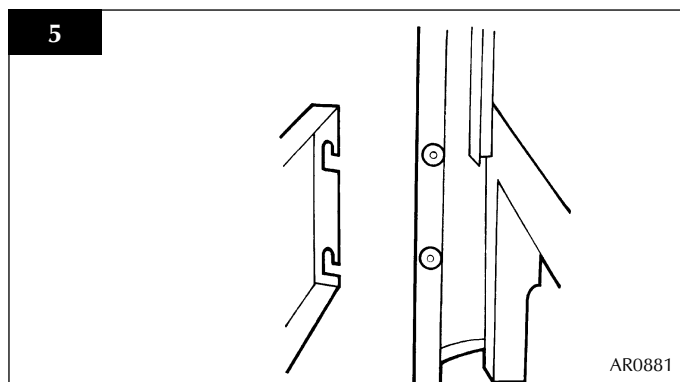

- 3.9 Place the steel top onto the casing so that the 2 lugs on the underside locate the top centrally within the casing. Place the cast iron grill into the recess in the centre of the top panel and locate the blanking plate into the grill (if required). See Diagram 6.

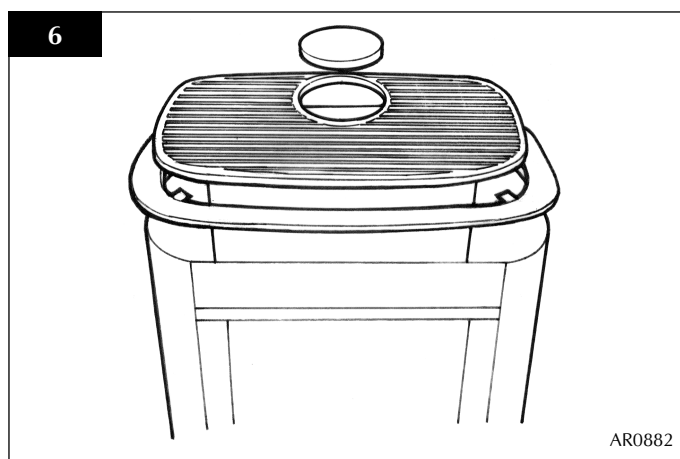

- 3.10 Check the pull of the flue system by applying a lighted smoke pellet to the flue system opening. If there is a definite flow into the chimney, proceed with the installation. If not, warm the chimney for a few minutes.

**IF THERE IS STILL NO DEFINITE FLOW, THE FLUE MAY REQUIRE ATTENTION - SEEK EXPERT ADVICE**

- 3.11 The flue system may now be connected to the stove. Ensure that all joints are sealed with a suitable fire resistant sealant. It is also recommended that a physical retention method be used at the flue spigot joint, self-tapping screws being favoured.
- 3.12 Connect a suitable pressure gauge to the test point located on the inlet fitting, and turn the gas supply on. Light the appliance to maximum and check that the supply pressure is as stated on the databadge. Turn the gas off and replace the test point screw. Turn the gas on and check the test point for gas soundness.

# INSTALLATION INSTRUCTIONS

## INSTALLATION

### 4. HANDLING & DISPOSAL OF FIRE CERAMICS

The fuel effect and side panels in this appliance are made from Refractory Ceramic Fibre (RCF), a material which is commonly used for this application.

Protective clothing is not required when handling these articles, but we recommend you follow normal hygiene rules of not smoking, eating or drinking in the work area and always wash your hands before eating or drinking.

To ensure that the release of RCF fibres are kept to a minimum, during installation and servicing a HEPA filtered vacuum is recommended to remove any dust accumulated in and around the appliance before and after working on it. When servicing the appliance it is recommended that the replaced items are not broken up, but are sealed within heavy duty polythene bags and labelled as RCF waste.

RCF waste is classed as stable, non-reactive hazardous waste and may be disposed of at a licensed landfill site.

Excessive exposure to these materials may cause temporary irritation to eyes, skin and respiratory tract; wash hands thoroughly after handling the material.

### 5. FUELBED ARRANGEMENTS

To gain access to the ceramic fuel pieces, it will be necessary to remove the glass door. Lift off the decorative steel trim, see Diagram 8 and remove the screws holding the glass frame. See diagram 9.

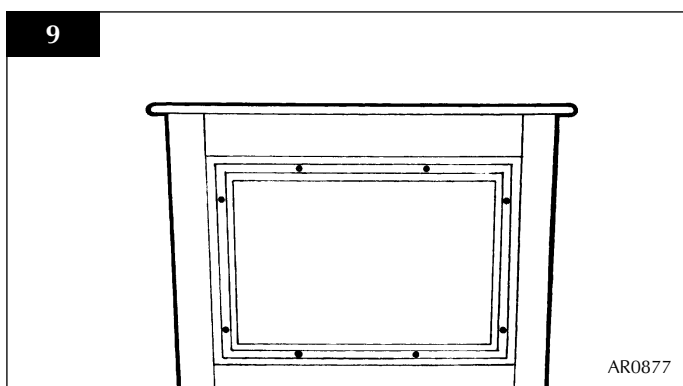
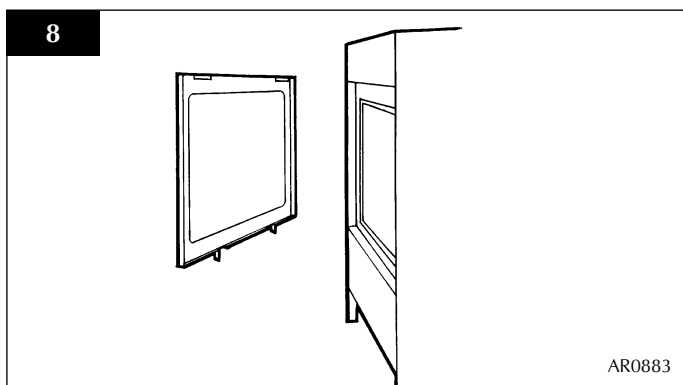

The fuel bed consists of 5 logs and 2 ash panels. The logs have letters A,B,C,D and E moulded into them for identification.

- 5.1 Take the rear log A and place it up against the rear of the fire sitting on the two flat ledges of the burner. The two legs of the log should sit between the rear burner ports. See diagram 10. Ensure an equal gap between each side of the log and the side of the firebox.

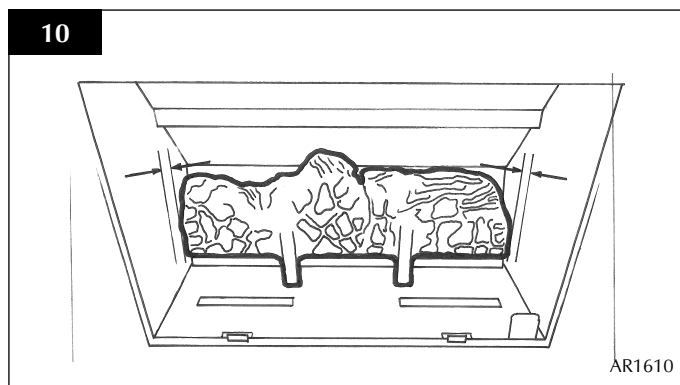

- 5.2 Place log B on the left-hand side of the burner with the location bar on the underside of the log fully located in the long slot of the burner. Make sure the log is as far to the left as possible. See diagram 11.

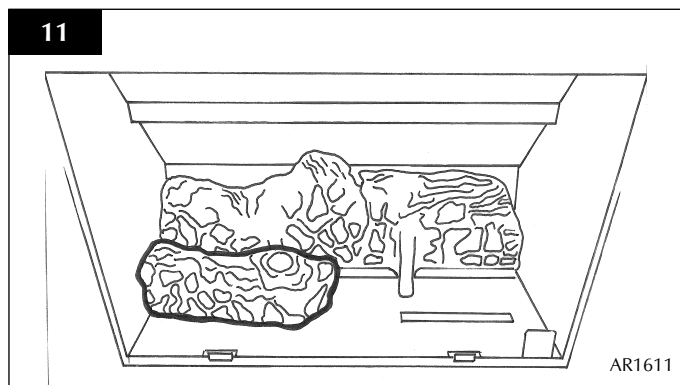

- 5.3 Place log C on the right-hand side of the burner with the location bar on the underside of the log fully located in the long slot in the burner. Make sure the log is as far right as possible. See diagram 12.

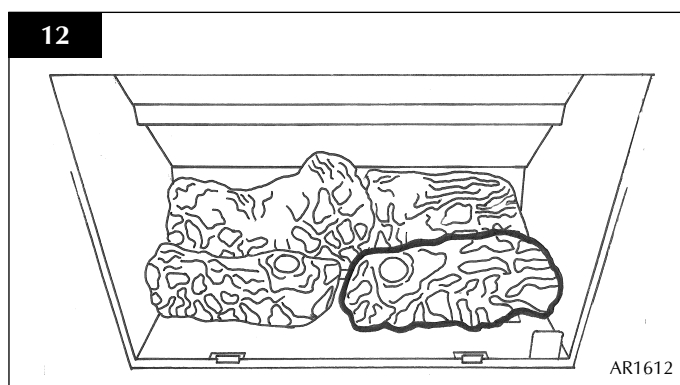

# INSTALLATION INSTRUCTIONS

- 5.4 Place log D across from the rear log A to log B on the left-hand side. There are cut-outs in both logs for location. See diagram 13.

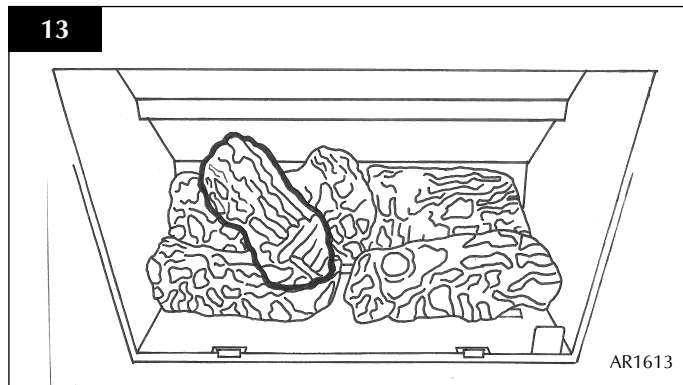

- 5.5 There are two ash panels which lay across the front of the burner skin. Place the panel with the flat edge facing the left side of the firebox. There are location holes on this log which fit over the screw holes of the burner skin.

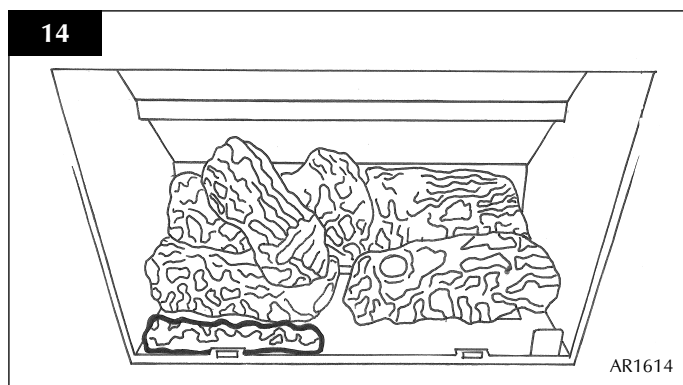

- 5.6 Place the second ash panel to the right of the first, with the pointed end of the panel fitting into the V shape. This panel should locate on the screw holes of the burner skin. Ensure that both logs are horizontal to the burner ports.

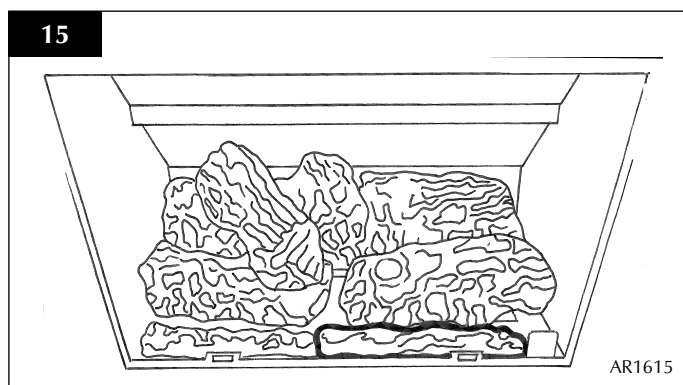

- 5.7 Place log E across from the rear of log A to log C on the right-hand side. Again, there are cut-outs for location. The front of the log should sit on the front ash panels and should fit tight to log C. See diagram 16.

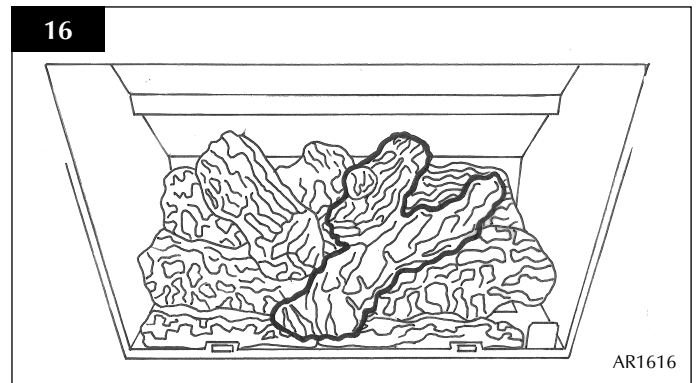

- 5.8 Carefully insert the front coal retainer into the front panel of the firebox. Take care not to scrape/damage the logs. This coal retainer sits in two brackets. Ensure it is fully inserted, leaving approximately a 4 mm gap between the firebox ledge and the bottom of the coal retainer.

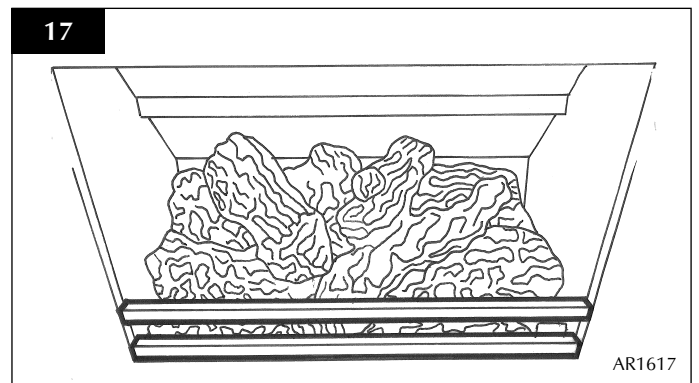

- 5.9 Ensure that the rope seal on the back of the glass frame is intact. Replace the glass frame making sure that the 8 screws are tightened evenly. Do not overtighten. See Diagram 18.

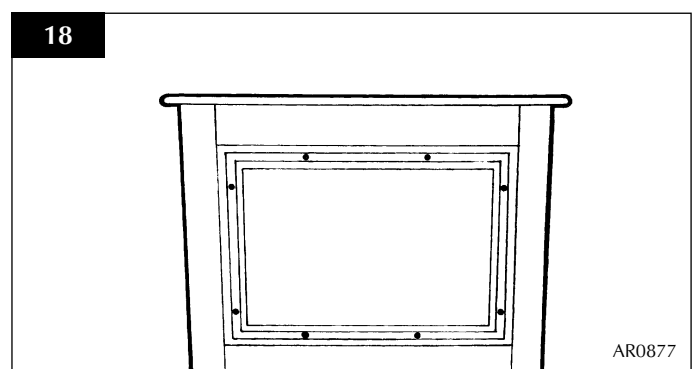

# INSTALLATION INSTRUCTIONS

## INSTALLATION

5.10 Hang the decorative steel trim onto the glass frame as shown in Diagram 19.

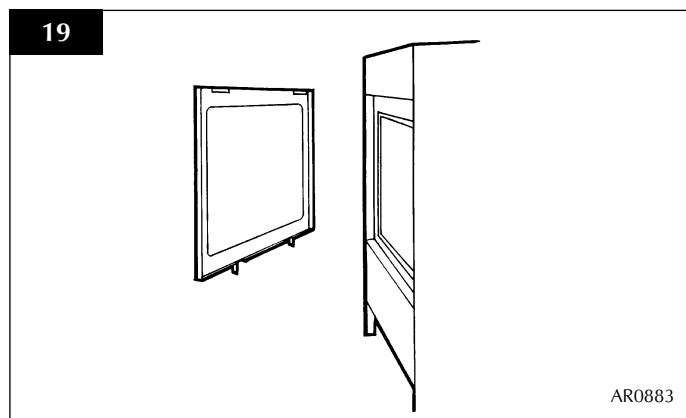

**NEVER OPERATE THE STOVE WHEN THE DOOR IS REMOVED OR WHEN THE GLASS IS BROKEN.**

### 6. LIGHTING

6.1 Full instructions are given in the User section under Lighting the Stove.

# INSTALLATION INSTRUCTIONS

## COMMISSIONING

### 1. COMMISSIONING

- 1.1 Close all openable doors and windows in the room, ignite the stove and operate on maximum for 10 minutes. Position a lighted smoke match just inside the draught diverter opening and check that all smoke is drawn into the opening by viewing through the sight hole. See diagram 1. If there is any doubt, run the stove for a further 10 minutes and repeat the test.

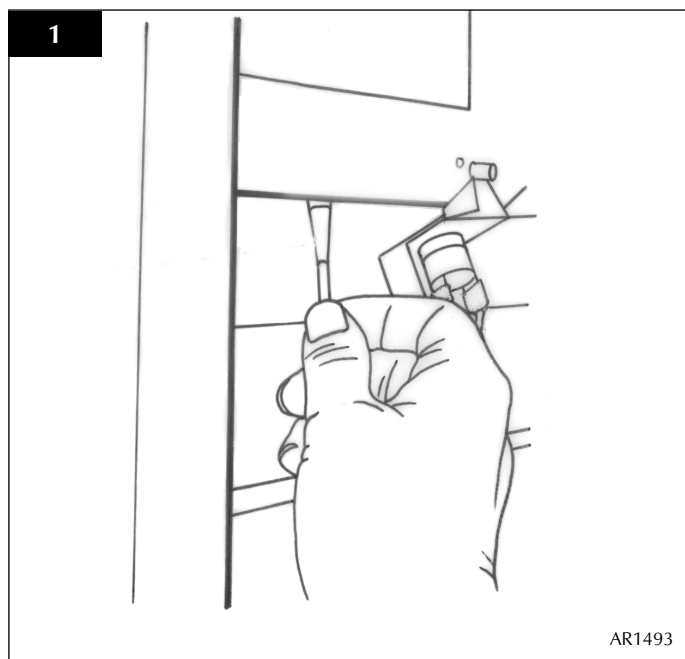

- 1.2 If there are any extractor fans in adjacent rooms, the test must be repeated with the fans running on maximum and interconnecting doors open.

**IF SPILLAGE PERSISTS, DISCONNECT THE APPLIANCE AND SEEK EXPERT ADVICE.**

For future reference record the installation details on the commissioning sheet at the end of the User Section of these instructions.

# SERVICING INSTRUCTIONS

## SERVICING / FAULT FINDING CHARTS

### 1. SERVICING REQUIREMENTS

This appliance must be serviced at least once a year by a competent person.

All tests must be serviced by best practice as described by the current CORGI recommendations.

- 1.1 Before any tests are undertaken on the appliance, conduct a gas soundness test for the property to ensure that there are no gas leaks prior to starting work.
- 1.2 Before any tests are undertaken on the appliance it is also recommended to fully check the operation of the appliance
- 1.3 Special checks
  - 1.3.1 Clean any lint or fluff from the pilot
  - 1.3.2 Clean away any fluff or lint from under the burner
  - 1.3.3 Check that the spark gap on the pilot is correct
  - 1.3.4 Check all of the screws which secure the burner skins and tighten if they are loose.

1.4 Correct any faults found during the initial tests and then recommission the appliance conducting the usual safety checks.

1.5 Advise the customer of any remedial action taken.

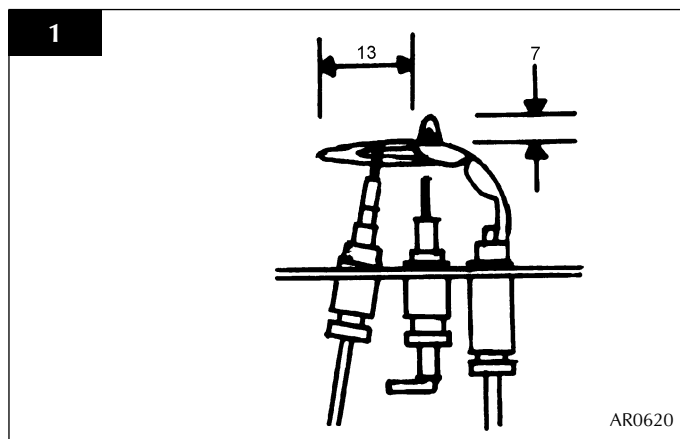

### IGNITION FUNCTIONAL CHECK 1

PILOT WILL NOT LIGHT

Ensure there is no debris around the pilot assembly, (e.g. soot, etc.) which could short the spark.  
Clean the area.

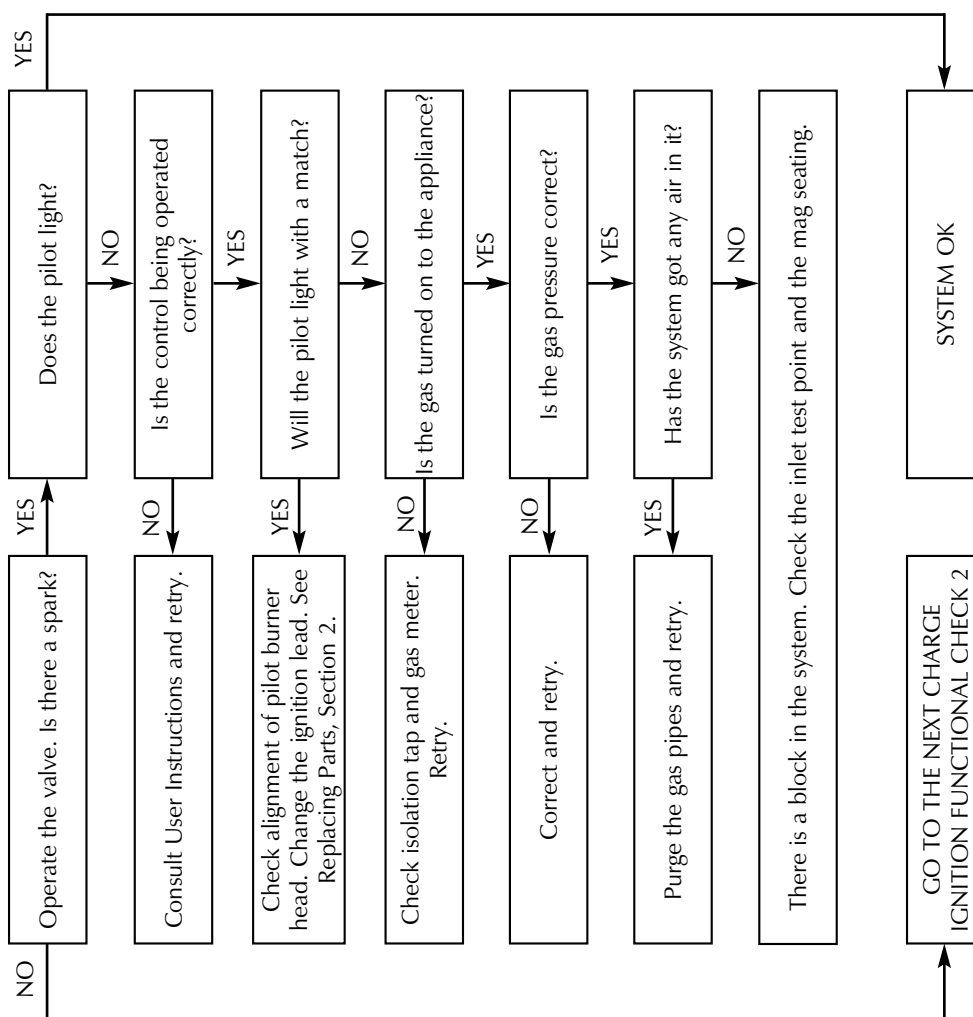



# SERVICING INSTRUCTIONS

## SERVICING / FAULT FINDING CHARTS

### IGNITION FUNCTIONAL CHECK 2

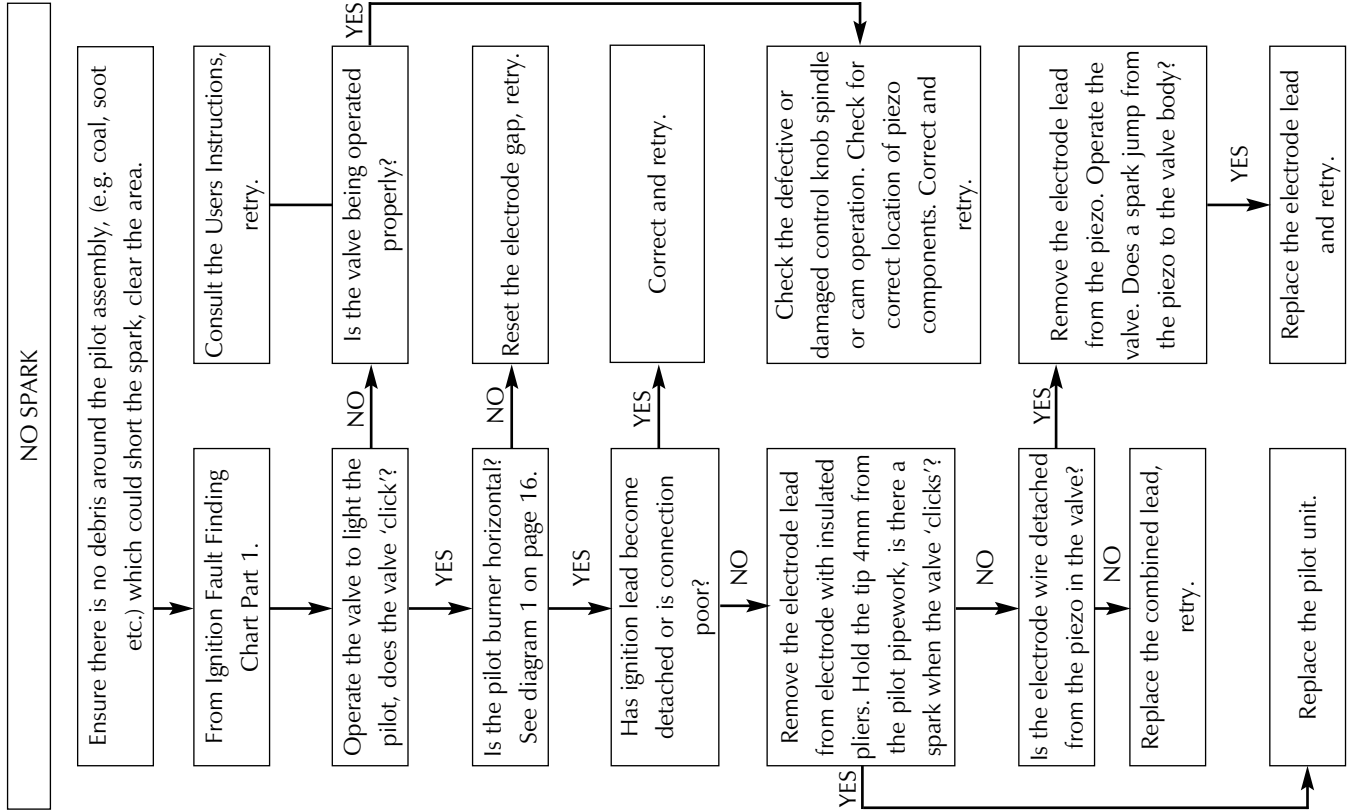

### FLAME FAILURE FUNCTIONAL CHECK 3

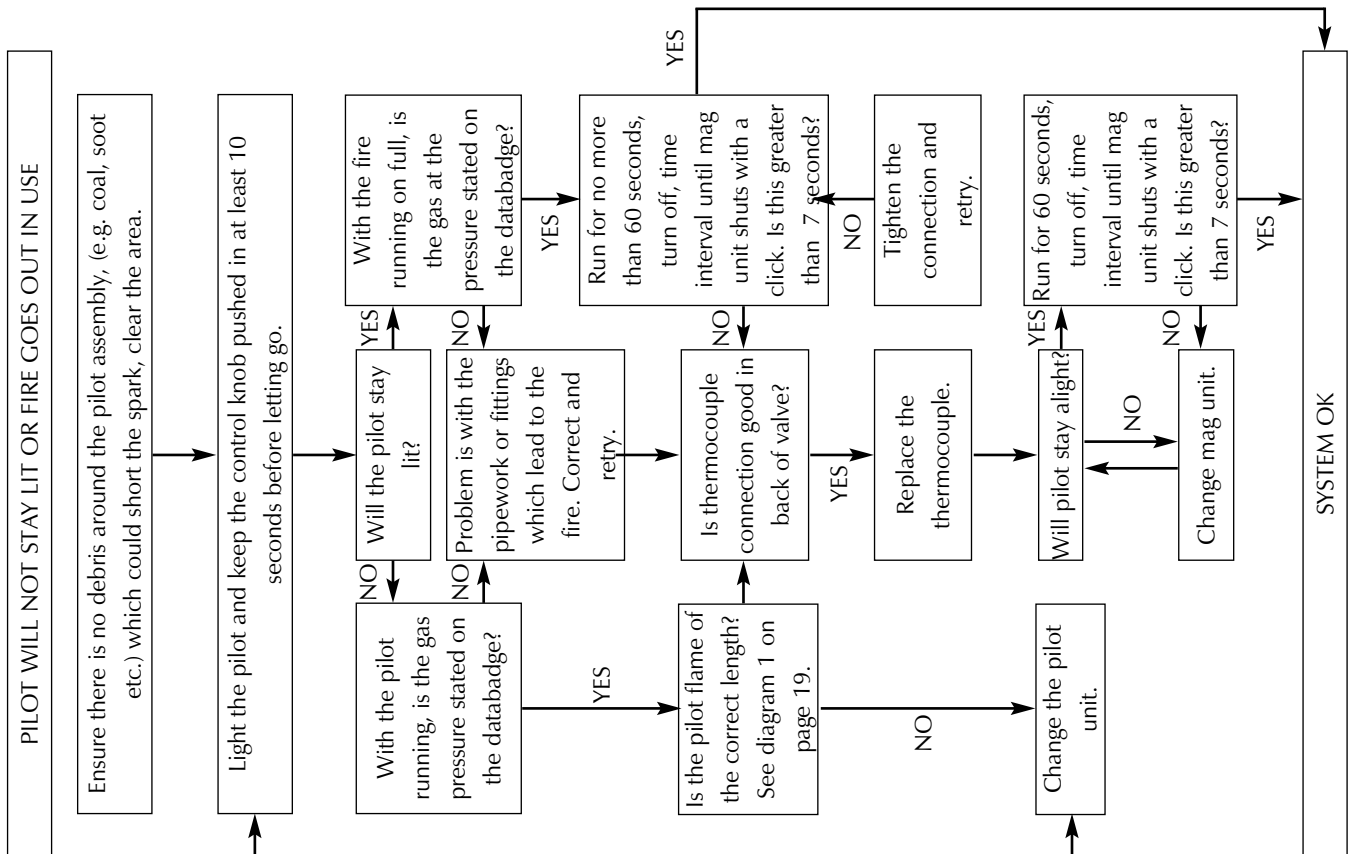

# SERVICING INSTRUCTIONS

## REPLACING PARTS

### 1. GENERAL

- 1.1 All principal components can be replaced without removing the stove from its installation, although it will be necessary to remove the door and steel outer casing in order to access most components. In order to remove the casing, using the following procedure:
- 1.2 Lift off the decorative steel trim see diagram 1 and remove the 8 screws holding the glass frame. See diagram 2.

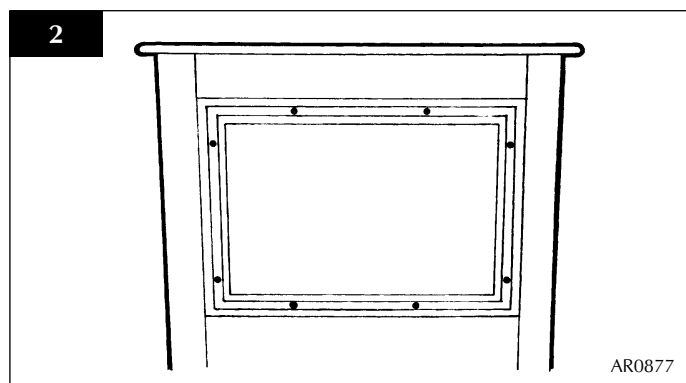
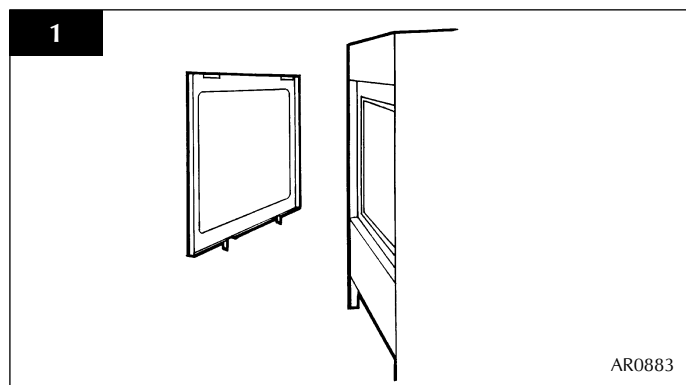

- 1.3 Carefully remove the top blanking plate and cast iron grill and place to one side. Remove the steel top. If the unit has been connected to the top exit flue, it will be necessary to lift and support the grill and steel top whilst removing the outer steel casing.
- 1.4 Remove the two front panels as shown. See diagrams 3 and 4.

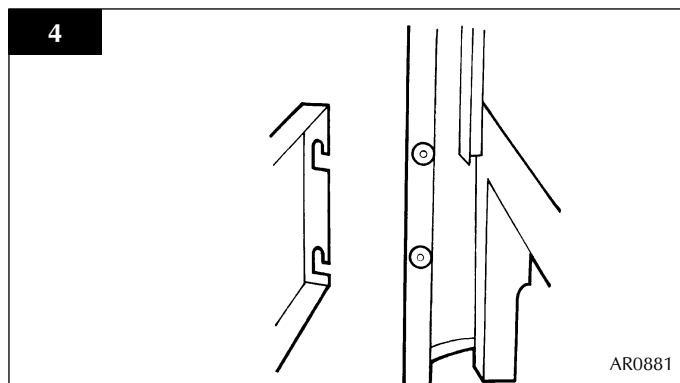
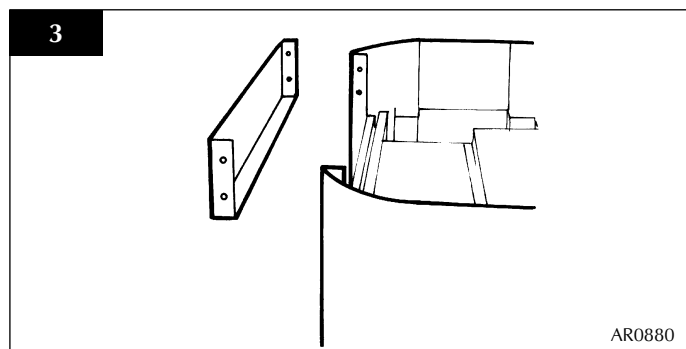

- 1.5 Lift the right-hand decorative panel to disengage from its locating brackets and remove from the stove. See Diagram 4. It may not be necessary to remove the left-hand side.
- 1.6 This should allow full access to all major components.

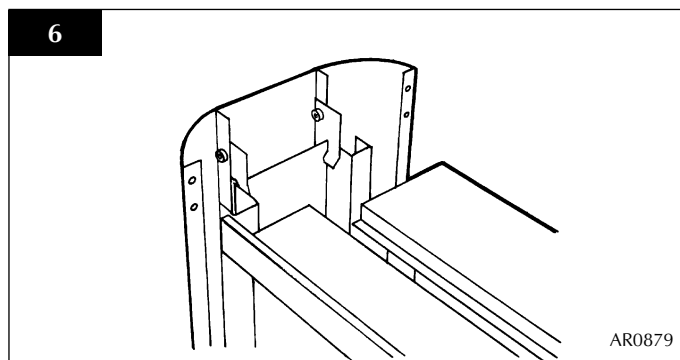
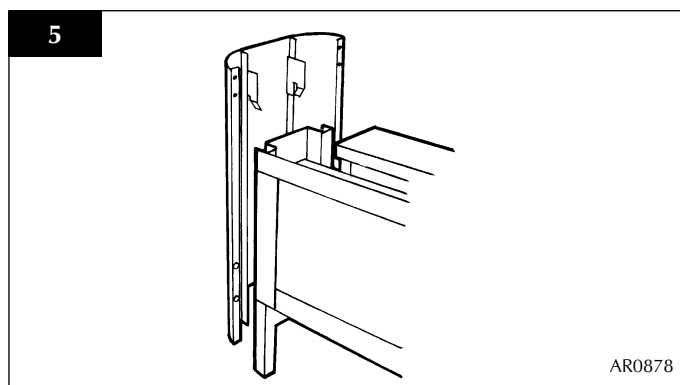

# SERVICING INSTRUCTIONS

## REPLACING PARTS

### 2. MAIN BURNER

- 2.1 Turn the gas supply off at the isolation device, remove the door and place to one side, carefully remove the ceramic fuel bed components.
- 2.2 Remove the three securing screws, two at the rear and one at the front left-hand side. See diagram 7. Raise the left-hand side of the burner to clear the bracket, draw the left-hand side forward. The burner venturi is engaged over the injector. When removing the burner be sure to clear the injector, this will release the right-hand side of the burner. Take care when removing the burner so as not to damage the pilot burner.

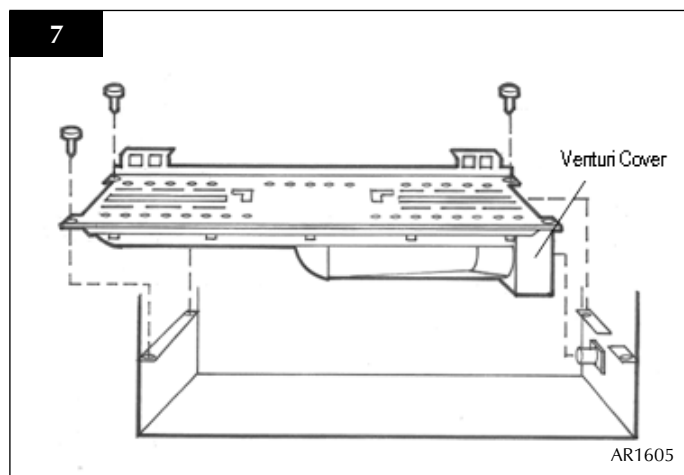

- 2.3 To replace the burner, engage the venturi over the injector ensuring the burner sits on top of the fixing bracket. Push the burner to the right and whilst holding, insert the three fixing screws.

**NOTE: BEFORE REPLACING THE BURNER, ENSURE THE SILICONE SEAL AROUND THE INJECTOR IS INTACT AND CHECK THAT VENTURI COVER IS ATTACHED.**

### 3. PILOT UNIT

- 3.1 The pilot assembly consists of four components that can be individually changed, these are:
  - 1) Pilot burner bracket
  - 2) Pilot injector
  - 3) Electrode
  - 4) Thermocouple
- 3.2 Turn the gas supply off at the isolation device. Remove the door and place to one side and carefully remove the ceramic fuelbed components.
- 3.3 Remove the main burner. See Section 2 above.
- 3.4 Remove the two fixing screws from the pilot bracket. See Diagram 8. Gently draw the assembly away from the firebox to give access to the nuts and ignition lead.

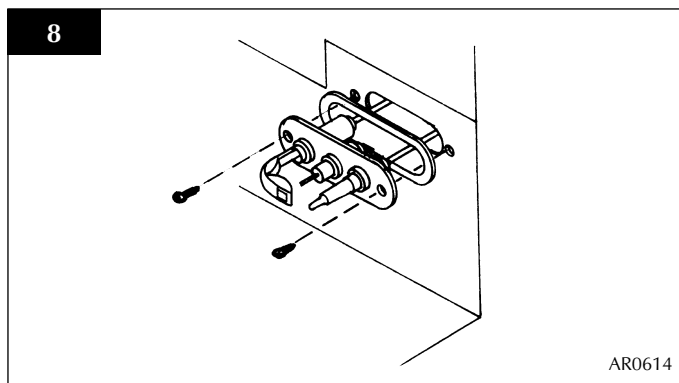

- 3.5 To remove the pilot injector, undo the compression nut on the pilot feed pipe and withdraw the injector which will be hooked onto the olive. When replacing an injector always make sure it is hooked onto the olive before inserting it into

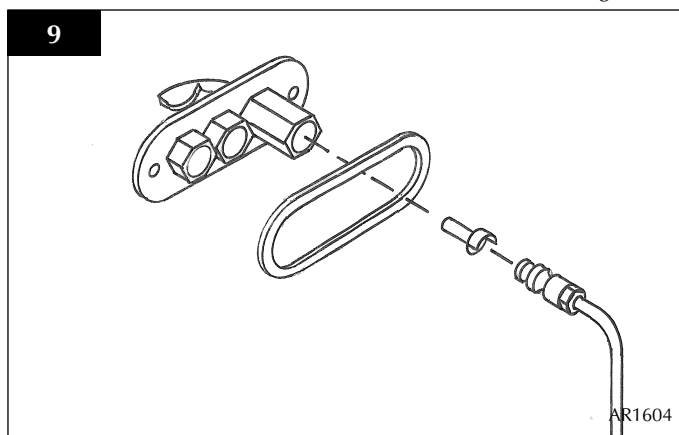

the pilot burner. See diagram 9.

- 3.6 To remove the electrode, disconnect the ignition lead and undo the retaining nut. The electrode can now be removed. Note the orientation of the electrode terminal when

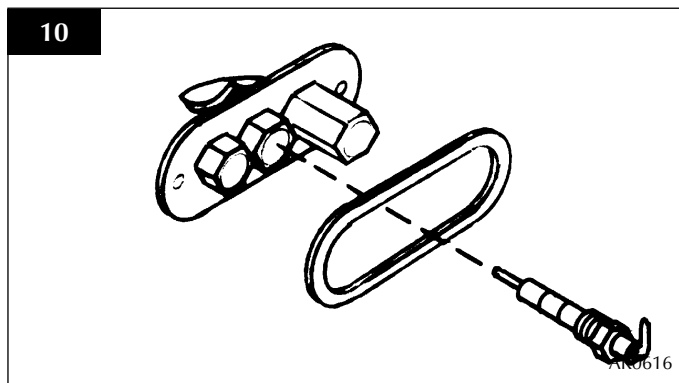

reassembling. See diagram 10.

# SERVICING INSTRUCTIONS

## REPLACING PARTS

- 3.7 To remove the thermocouple, undo the retaining nut and withdraw the thermocouple. Undo the thermocouple from the back of the gas valve. See Diagrams 11 and 12. Reassemble in reverse order. Do not overtighten.

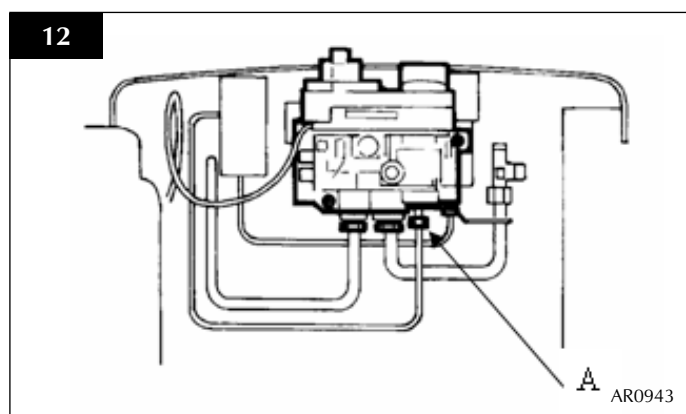
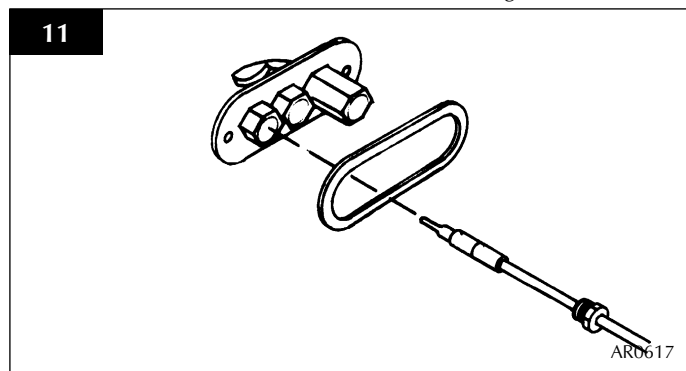

**NOTE: SPECIAL CARE SHOULD BE TAKEN WHEN REPLACING THE THERMOCOUPLE TO THE BACK OF THE GAS VALVE ENSURING THAT THE SENSOR WIRES FOR THE GAZCO FLUE SURE SYSTEM ARE NOT DISCONNECTED.**

### 4. IGNITION LEAD

- 4.1 Gain access to the back of the pilot assembly, see Section 3 above and disconnect the ignition lead from the electrode.  
4.2 Undo the single screw that secures the left-hand side of the control cover, see Diagram 13.

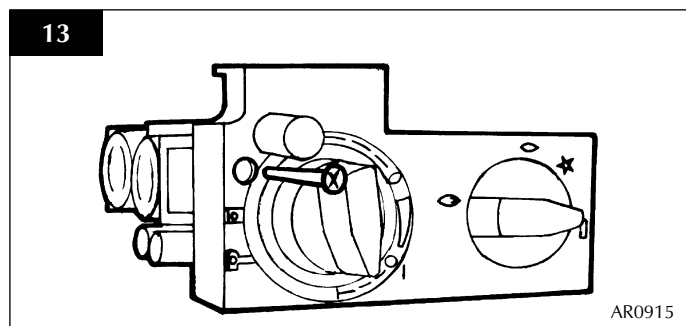

- 4.3 To release the right-hand side of the control cover insert the narrow blade screwdriver into the slot shown in diagram 14. Lever it gently and pull from the right-hand side at the same time. The cover will now come off. There is a small cylindrical metal spacer inside the cover; this must be kept and replaced on the fixing screw during reassembly.

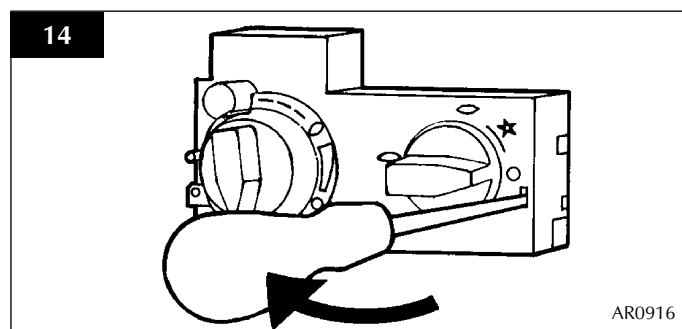

- 4.4 Disconnect the end of the ignition lead from the valve body, see diagram 15, Arrow B, note the existing route of the ignition lead.

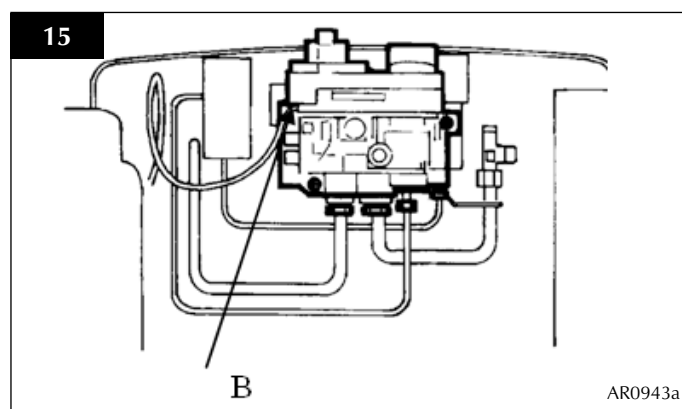

- 4.5 Replace with a new ignition lead following the same route as the old one. Replace the valve cover and the pilot assembly.  
4.6 Check the operation of the new ignition lead.

### 5. PIEZO

- 5.1 The piezo assembly used on this appliance is not serviceable and is unlikely to fail.

### 6. GAS VALVE

- 6.1 Turn the gas supply off at the isolation device.  
6.2 Disconnect the 2 x 8mm and 1 x 4mm gas pipe fittings at the back of the gas valve and also disconnect the thermocouple, see Diagram 16, Arrow A.  
6.3 Remove the control valve cover and disconnect the ignition lead from the gas valve, see section 4.  
6.4 Undo the two bolts securing the gas valve to the appliance and remove the valve, see diagram 16, Arrow C  
6.5 Replace in reverse order.

# SERVICING INSTRUCTIONS

## REPLACING PARTS

- 6.6 Check all joints for gas leaks. Check the operation of the thermocouple and ignition lead.

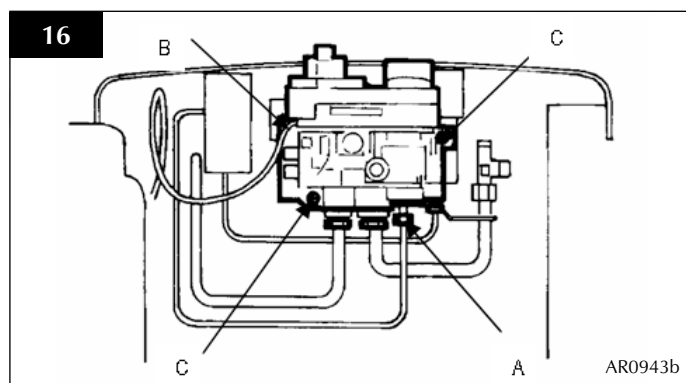

### 7. MAGNETIC SAFETY VALVE

- 7.1 Turn the gas supply off at the isolation device. Undo the thermocouple connection from the back of the gas valve. Pull the sensor leads clear and remove the interrupter block.
- 7.2 Undo the mag valve retaining nut at the back of the control valve. Gently tap out the mag valve and replace with a new unit. Replace the retaining nut and tighten. See diagram 17, Arrow A.

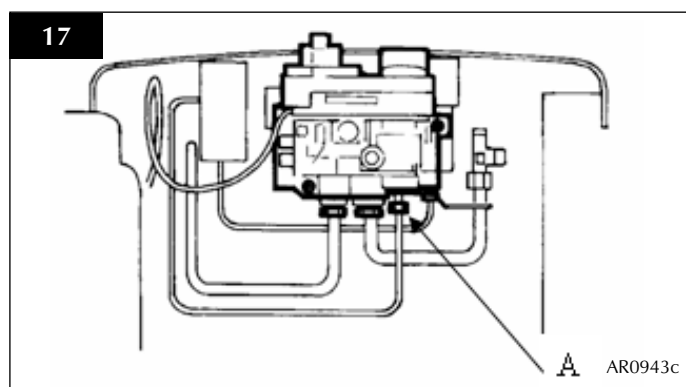

- 7.3 Reassemble the interrupter block and leads. Secure the thermocouple connection in the rear of the gas control (Do not overtighten). Turn the gas supply on and check the entire pipework and valve joints for any leaks.

### 8. MAIN INJECTOR

- 8.1 Turn the gas supply off at the isolation device. Refer to Section 2, Replacing Parts to remove the main burner.
- 8.2 Undo the compression nut from the feed pipe at the gas control under the appliance.
- 8.3 Working from inside the firebox, remove the lock nut from the injector and withdraw the injector complete with the feed pipe from under the appliance. See diagram 18.

18

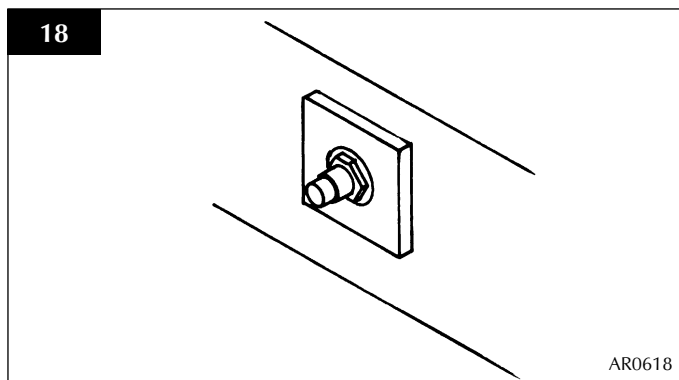

- 8.4 Holding the injector with a spanner, undo the feed pipe.  
**NOTE: THE ORIENTATION OF THE INJECTOR.**
- 8.5 Reassemble in reverse order. Turn on the gas supply and check for any leaks.

### 9. GAZCO FLUE SURE SYSTEM

- 9.1 Lift off the decorative steel trim and remove the 8 screws holding the glass frame. Carefully remove the coal retainer and ceramic components and place to one side. Remove the burner casting by removing the three screws located on the sides of the burner skin.

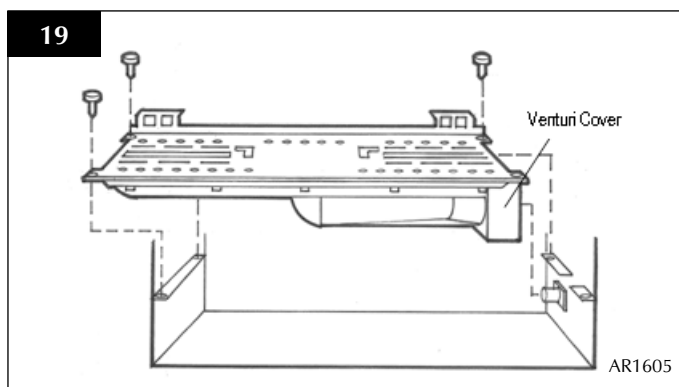

- 9.2 Remove the screw on the back panel and remove the panel. Refer to Diagram 20.

20

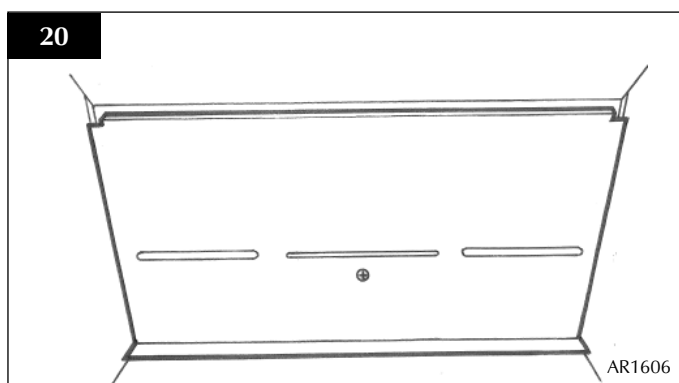

# SERVICING INSTRUCTIONS

## REPLACING PARTS

- 9.3 Undo the two screws at the back of the firebox and carefully withdraw the bracket.

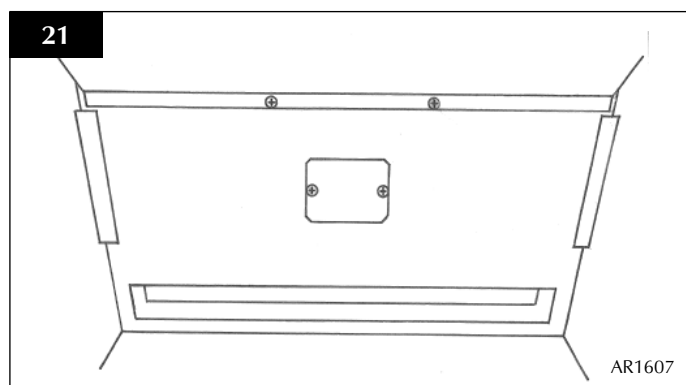

- 9.4 Disconnect the two slender wires. Undo the two tapite screws and remove the sensor and the two plastic spacers. See diagram 22.

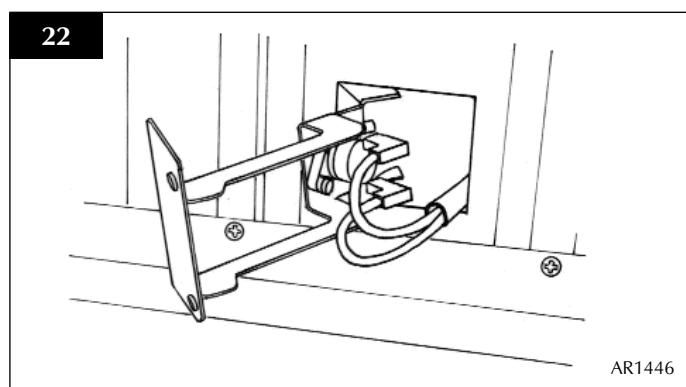

- 9.5 Refit the new sensor, ensuring that the plastic spacers are between the sensor and the bracket. Refit the leads. See Diagram 23.

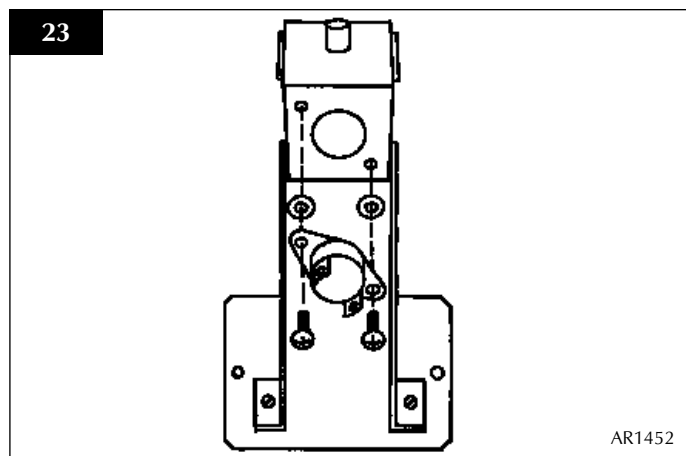

- 9.6 Feed the cable back through the hole as you replace the bracket. When the bracket is located correctly it will sit flush with the back panel without force required. If not positioned correctly the bracket will sit at an angle. See Diagram 24.

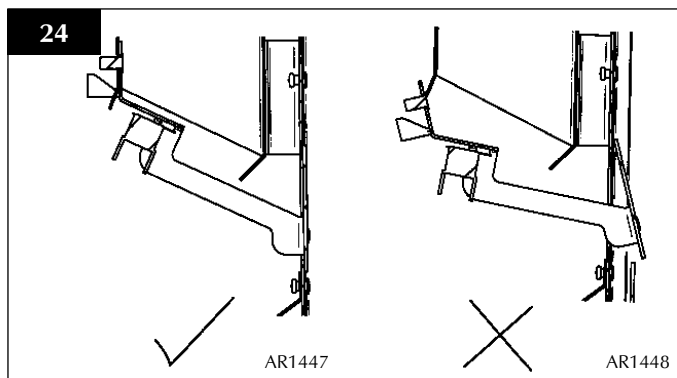

### 10. PRIMARY AERATION PLATE

- 10.1 Turn the gas supply off at the isolation device.  
10.2 Refer to Section 2 to remove the main burner.  
10.3 Remove the two screws on the burner skin to detach the venturi cover from the venturi. Slide the venturi cover off the venturi as per diagram 25.

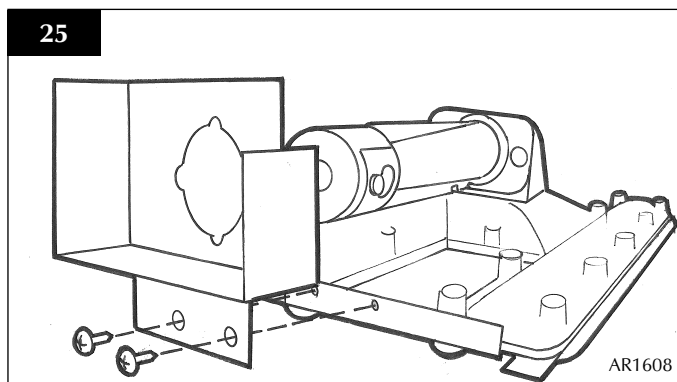

- 10.4 Change the aeration plates to those stated in the technical specification for the gas the product will be using, refer to the databadge.

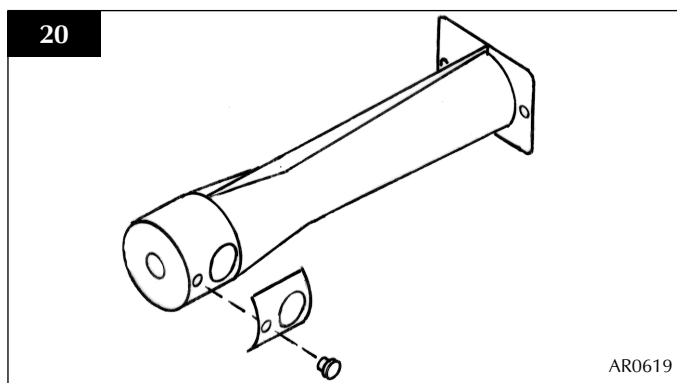

- 10.5 Reassemble in reverse order with correct aeration plate(s).  
**NOTE: Even if no aeration plate is required, the small screw(s) must be replaced.**

# SERVICING INSTRUCTIONS

## REPLACING PARTS

### 11. CHANGING BETWEEN GAS TYPES

In order to change between gas types, it will be necessary to change the following items.

- Pilot Injector
- Control Valve
- Main Injector
- Main Burner
- Aeration Plate (if required)
- Databadge

The relevant parts can be ordered from Gazco, always quote the appliance type and serial number when ordering spare parts.

**\*\* NOTE: THE CONTROL VALVE IS FACTORY PRESET FOR CORRECT GAS TYPE AND MODEL, A NEW UNIT WILL NEED TO BE ORDERED WHEN CHANGING BETWEEN GAS TYPES.**

### 12. CONTROL UPGRADE

See Installation, Section 1.

### 13. SHORT SPARES LIST

Component	NG		LPG
	G20 20mb	G30 29mb	G31 37mb
Main Injector	IN0045	IN0030	IN0030
Aeration plate	N/A	N/A	GZ5387
Pilot injector	PI0026	PI0015	
Burner assembly	GZ5369	GZ5388	
Thermocouple	PI0010		
Magnetic unit	GC0092		
Electrode	PI0053		
Pilot Gasket	PI0052		
Gas valve	GC0088K		
Ignition lead	GC0090		
Complete log set	CEO583		
Log A	CEO584		
Log B	CEO585		
Log C	CEO586		
Log D	CEO587		
Log E	CEO588		
Left ash panel	CEO589		
Right ash panel	CEO590		
TTB	EL0001		
TTB Lead	EL0064		
Interrupter block	GC0026		
Standard upgrade kit	8455		
Thermostat/timer kit	8456		

# SERVICE RECORDS

## 1ST SERVICE

Date of Service:.....

Next Service Due:.....

Signed:.....

Dealer's Stamp/CORGI Registration Number

## 2ND SERVICE

Date of Service:.....

Next Service Due:.....

Signed:.....

Dealer's Stamp/CORGI Registration Number

## 3RD SERVICE

Date of Service:.....

Next Service Due:.....

Signed:.....

Dealer's Stamp/CORGI Registration Number

## 4TH SERVICE

Date of Service:.....

Next Service Due:.....

Signed:.....

Dealer's Stamp/CORGI Registration Number

## 5TH SERVICE

Date of Service:.....

Next Service Due:.....

Signed:.....

Dealer's Stamp/CORGI Registration Number

## 6TH SERVICE

Date of Service:.....

Next Service Due:.....

Signed:.....

Dealer's Stamp/CORGI Registration Number

## 7TH SERVICE

Date of Service:.....

Next Service Due:.....

Signed:.....

Dealer's Stamp/CORGI Registration Number

## 8TH SERVICE

Date of Service:.....

Next Due:.....

Signed:.....

Dealer's Stamp/CORGI Registration Number

## 9TH SERVICE

Date of Service:.....

Next Due:.....

Signed:.....

Dealer's Stamp/CORGI Registration Number

## 10TH SERVICE

Date of Service:.....

Next Service Due:.....

Signed:.....

Dealer's Stamp/CORGI Registration Number



**Gazco Limited, Osprey Road, Sowton Industrial Estate, Exeter, Devon, England EX2 7JG**  
**Tel: (01392) 261999 Fax: (01392) 444148 E-mail: [info@gazco.com](mailto:info@gazco.com)**

A member of the Stovax Group