



Ceramica Coal Effect Stove Range Conventional Flue

With upgradeable control valve

Instructions for Use, Installation and Servicing For use in GB, IE (Great Britain and Eire)

This appliance has been certified for use in countries other than those stated. To install this appliance in these countries, it is essential to obtain the translated instructions and in some cases the appliance will require modification. Contact Gazco for further information.

IMPORTANT

Do not attempt to burn rubbish in this fire. This stove must only be operated with the door secured firmly in position. The outer casing of this stove will become hot whilst in operation, it is therefore recommended that the appliance be guarded to protect the young and infirm using a suitable guard.

Ensure that fabrics such as curtains are not positioned above or near to the stoves outer casing.

**Please read these Instructions carefully and keep them in a safe place.
They will be needed when servicing the fire.**

The commissioning sheet found on page 3 should be completed by the installer.

CONTENTS

COVERING THE FOLLOWING MODELS:
CERAMICA MANHATTAN 8578-P8578

| | PAGE |
|--|-----------|
| APPLIANCE COMMISSIONING CHECKLIST | 3 |
| USER INSTRUCTIONS | 4 |
| INSTALLATION INSTRUCTIONS | 10 |
| Technical Specifications | 10 |
| Site Requirements | 11 |
| Installation | 12 |
| Commissioning | 17 |
| SERVICING INSTRUCTIONS | 18 |
| Servicing Requirements | 18 |
| Fault Finding | 19 |
| How to replace parts | 20 |
| Basic spare parts list | 24 |
| Service records | 25 |

APPLIANCE COMMISSIONING CHECKLIST

IMPORTANT NOTICE

Explain the operation of the appliance to the end user, hand the completed instructions to them for safe keeping, as the information will be required when making any guaranteed claims.

| FLUE CHECK | PASS | FAIL |
|--|---|-------|
| 1. Flue is correct for appliance | | |
| 2. Flue flow test | | |
| 3. Spillage test | | |
| GAS CHECK | | |
| 1. Gas soundness & let by test (Please circle Y / N as appropriate) | Y / N | Y / N |
| 2. Standing pressure test in figures (e.g. 20 mb) | | mb |
| 3. Appliance working pressure (on High Setting) in figures (e.g. 20 mb) NB All other gas appliances must be operating on full | | mb |
| 4. Gas rate | m ³ /h | |
| 5. Does ventilation meet appliance requirements | | |
| 6. Have controls been upgraded (Upgradeable models only) | 8455 Standard YES | NO |
| | 8456 Programmable Time & Temperature YES | NO |

DEALER AND INSTALLER INFORMATION

Dealer

Installation Company

Contact No.

Engineer

Date of Purchase

Contact No.

Model No.

Corgi Reg No.

Serial No.

Date of Installation

Gas Type

This product is guaranteed for 2 years from the date of installation, as set out in the terms and conditions of sale between Gazco and your local Gazco dealer. **This guarantee will be invalid, to the extent permitted by law, if the above Appliance Commissioning Checklist is not fully completed by the installer and available for inspection by a Gazco engineer.** The guarantee will only be valid during the second year, to the extent permitted by law, if the annual service recommended in the Instructions for Use has been completed by a Corgi registered engineer, and a copy of the service visit report is available for inspection by a Gazco engineer.

USER INSTRUCTIONS

1. GENERAL

- 1.1 Installation and servicing must be carried out by a competent person in accordance with Gas Safety (Installation and Use) Regulations 1998, the relevant British Standards for Installation, appropriate Codes of Practice and in accordance with the manufacturers instructions. It is a requirement that a CORGI registered engineer be used for this purpose as they are approved by the HSE under the above regulations.
- 1.2 This appliance is suitable for use in G.B. and I.E. using Natural Gas at a supply pressure of 20mbar or LPG at a supply pressure of 29mbar (Butane) or 37mbar (propane).
- 1.3 The installation shall also be completed in accordance with: The Building Regulations issued by The Department of The Environment.
The Building Standards (Scotland) Regulations issued by the Scottish Development Department.
For Republic of Ireland, reference should be made to the relevant standards governing installations (IS813:1996)
- 1.4 Read all these instructions before commencing installation.
- 1.5 This appliance must be installed in accordance with the rules in force and only used in a sufficiently ventilated space.
- 1.6 Ensure that curtains are not positioned above the stove, and that there is at least a clearance of 300mm between the sides of the stove and any curtains.
- 1.7 The manufacturer considers the full outer casing of this stove to be a working surface which becomes hot whilst in operation. A suitable guard is recommended to protect young children, the aged and the infirm.
- 1.8 This stove must only be operated with the door secured firmly in position. If any cracks appear in the glass the appliance must not be used until the glass panel is replaced.
- 1.9 Do not attempt to burn rubbish in this stove.
- 1.10 Any combustible shelves or surrounding furniture must only be fitted in accordance with the minimum dimensions detailed in Diagram 1.

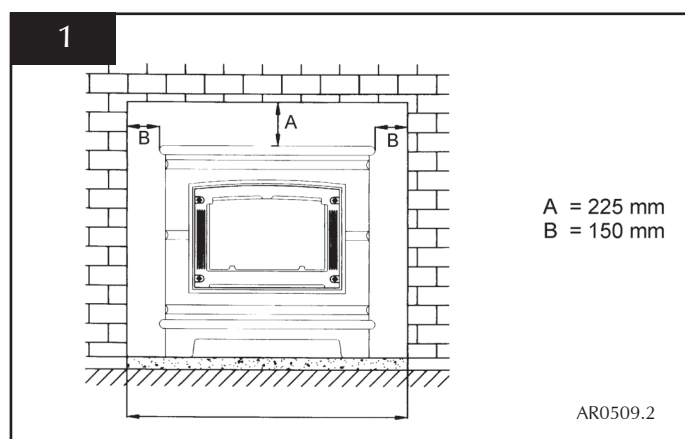

- 1.11 Contact a competent service engineer to carry out relevant spillage checks etc. following home improvements carried out after installation of this stove (e.g. the fitting of double glazing).
- 1.12 In all correspondence, please quote the appliance type and serial number which can be found on the databadge at the rear of the stove.
- 1.13 This product is guaranteed for 2 years from the date of installation, as set out in the terms and conditions of sale between Gazco and your local Gazco dealer. Please consult with your local Gazco dealer if you have any questions. In all correspondence always quote the Model No. and Serial No. Please ensure the commissioning checklist is completed by your installer; this is a requirement of your Guarantee.

2. LIGHTING THE APPLIANCE

- 2.1 Locate the control valve on the appliance. There are two control knobs on the valve:
 - right controls the pilot ignition
 - left controls the main burner.
- 2.2 If your appliance has already been upgraded to battery remote control, please refer to the instructions provided with the upgrade to operate the remote control. The following instructions work for either situation.

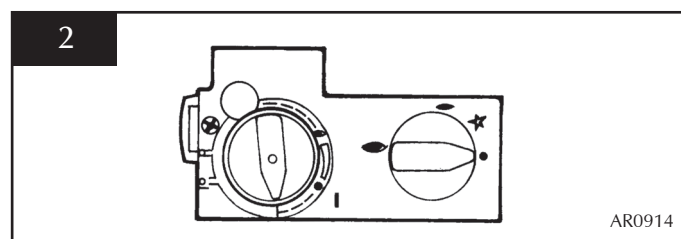

- 2.3 Ensure that the left-hand control knob is pointing to off (●).
- 2.4 Ensure that the right-hand control knob is pointing to off (●).
- 2.5 Press in the right-hand control knob and, keeping the knob depressed, turn it anti-clockwise until a click is heard and the knob is pointing to pilot (↶). The pilot should now light. If the pilot does not light, release the knob and repeat the procedure until it does.
- 2.6 Keep the control knob pressed in for 10 seconds and then release it, the pilot should stay alight. If the pilot goes out, repeat the procedures until it remains lit.
- 2.7 If the pilot does not light after repeated attempts, contact the retailer or installer from whom the appliance was purchased.
- 2.8 Turn the right-hand control to point to main burner (↷). The appliance can now be controlled using the left-hand control knob.
- 2.9 Turn the left-hand control knob to point to low fire (↷), the main burner lights on low. The burner can now be controlled between low and high settings. Turn the control knob anticlockwise to increase the flame height and clockwise to decrease the flame height.

USER INSTRUCTIONS

THE YELLOW FLAMES WILL APPEAR WHEN THE FIRE HAS REACHED SUFFICIENT HEAT - TYPICALLY 10 TO 20 MINUTES.

IF THE APPLIANCE IS EXTINGUISHED OR GOES OUT IN USE, WAIT 3 MINUTES BEFORE ATTEMPTING TO RE-LIGHT THE APPLIANCE.

3. TURNING THE STOVE OFF

- 3.1 To turn the stove off, locate the control valve, turn the left-hand control knob until it points to off (●). The main burner goes out leaving the pilot burning.
- 3.2 To turn the pilot off, locate the control valve, turn the right-hand control knob until it points to off (●), the pilot goes out.

4. UPGRADING YOUR STOVE

- 4.1 Your stove is fitted with a control valve that can easily be upgraded to battery powered remote control. This upgrade can be fitted by anyone capable of simple DIY jobs and requires no special training. There are two versions of this control which can be obtained through your local Gazco stockist.
- 4.2 **STANDARD REMOTE CONTROL.** This remote controls the gas appliance after the pilot has been lit. It can turn the main burner on and regulate it from low through to high and back again. It can turn the main burner off leaving the pilot burning GAZCO PART NUMBER 8455.
- 4.3 **THERMOSTATIC AND TIMER REMOTE CONTROL.** This remote controls the gas appliance after the pilot has been lit. In 'MANUAL MODE' it can be used to turn the main burner on and manually regulate it from low through to high and back again. It can also be used to turn the main burner leaving the pilot burning. In 'AUTO MODE' it will automatically regulate the room temperature to a pre-set temperature. In 'TIMER MODE' it will turn the fire on and off according to a pre-set programme and automatically regulate the room temperature during the two ON periods. GAZCO PART NUMBER 8456.

5. CLEANING THE FIRE

WARNING: DO NOT ATTEMPT TO CLEAN THE STOVE UNTIL IT IS COLD. THE STOVE RETAINS ITS HEAT FOR A CONSIDERABLE TIME AFTER SHUTDOWN.

NOTE: THE CAST IRON DOOR IS HEAVY, TAKE EXTREME CARE WHEN HANDLING.

- 5.1 Remove the door by undoing the four dome nuts using the tool supplied and place to one side.
- 5.2 Carefully remove the ceramic fuel bed components and place to one side taking care to protect floor coverings etc, **PLEASE HANDLE WITH CARE.**
- 5.3 The coals should not require cleaning. Do not use a vacuum cleaner or brush to clean the coals, any large pieces of debris can be removed by hand.

- 5.4 Ensure any debris is removed from the burner ports.
- 5.5 Replace the ceramics by referring to section 6.
- 5.6 Use a damp cloth to clean the outer casing of the appliance.

Advice on Handling and disposal of fire ceramics

- 5.7 The fuel effect and side panels in this appliance are made from Refractory Ceramic Fibre (RCF), a material which is commonly used for this application.
Protective clothing is not required when handling these articles, but we recommend you follow normal hygiene rules of not smoking, eating or drinking in the work area and always wash your hands before eating or drinking.
To ensure that the release of RCF fibres are kept to a minimum, during installation and servicing a HEPA filtered vacuum is recommended to remove any dust accumulated in and around the appliance before and after working on it. When servicing the appliance it is recommended that the replaced items are not broken up, but are sealed within heavy duty polythene bags and labelled as RCF waste.
RCF waste is classed as stable, non-reactive hazardous waste and may be disposed of at a licensed landfill site.
Excessive exposure to these materials may cause temporary irritation to eyes, skin and respiratory tract; wash hands thoroughly after handling the material.

6. FUEL BED ARRANGEMENT

The major ceramic components can be found inside the firebox. Remove the cast iron door using the tool provided, and remove all the protective packaging from these components. See Diagram 3.

NOTE: THE CAST IRON IS HEAVY, TAKE EXTREME CARE WHEN HANDLING.

The loose coals should be arranged as specified in the following steps. Care should be taken to ensure that there is sufficient space between the coals to allow flames to pass through.

USER INSTRUCTIONS

Medium Ceramics

- 6.1 Place the flame baffle onto the shelf at the rear of the tray and push up against the rear ledge, see Diagram 3.

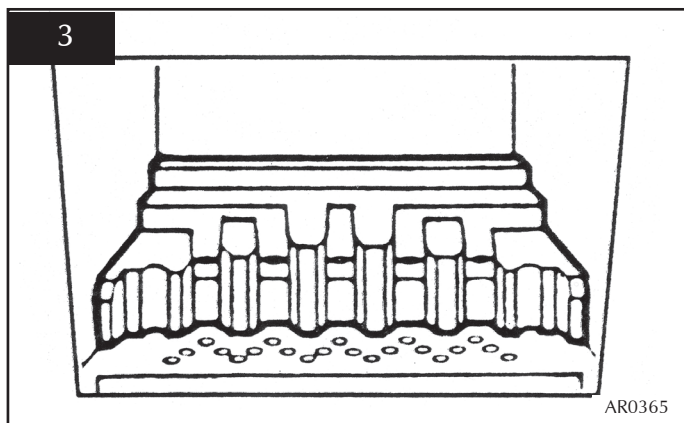

- 6.2 Locate the front coal moulding in front of the flame baffle ensuring that the end legs sit flat against the burner skin, see Diagram 4.

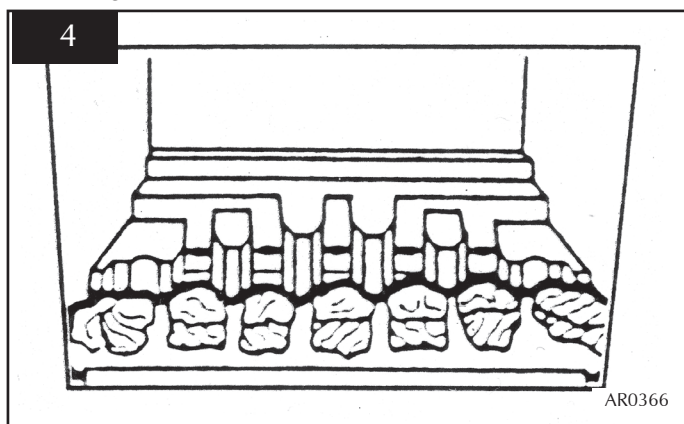

- 6.3 Place three large coals on the front coal so that they lean against the flame baffle, and the four large coals on the flame baffle so that they sit on the fingers, see Diagram 5.

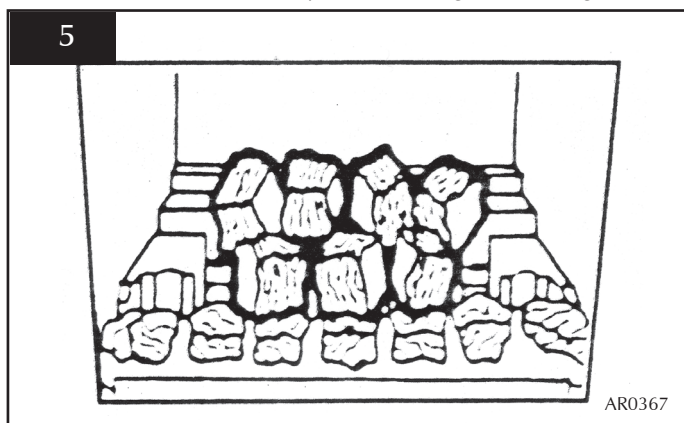

- 6.4 Place two small coals at each end of the front coal so that they lean against the flame baffle, and a further two large coals on the flame baffle, one at each end, see Diagram 6.

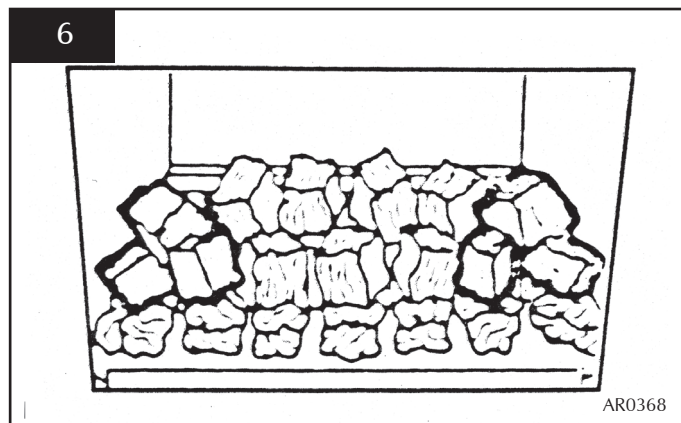

- 6.5 Place five small coals along the rear of the flame baffle, resting against the rear ledge, see Diagram 7.

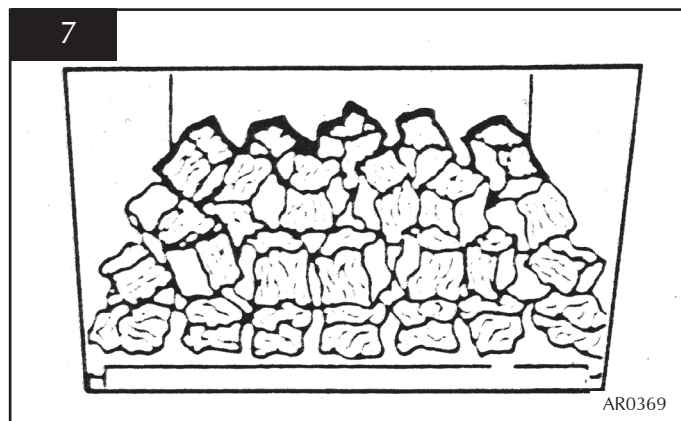

- 6.6 Ensure that the fibreglass seal on the back of the door is intact, locate the door on the four studs and slide back to the firebox. Secure in place using the four dome nuts and the tool supplied, do not over tighten the nuts, see Diagram 8. Keep the tool with these instructions for future use.

NEVER OPERATE THE STOVE WHEN THE DOOR IS REMOVED OR WHEN THE GLASS IS BROKEN.

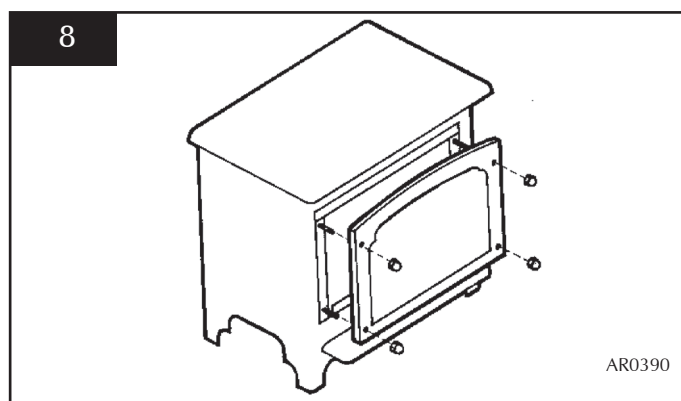

USER INSTRUCTIONS

7. GAZCO FLUE SURE SYSTEM

- 7.1 The stove is fitted with the Gazco Flue Sure System, which will act to cut off the gas supply to the burner in the event of incorrect operation of the flue. If the system acts to cut off the gas supply, this indicates that there is insufficient flue pull. If this occurs a minimum of 10 minutes should be allowed before trying to relight. Continued operation of this safety device means there may be a serious problem with the flue system. A qualified gas engineer should inspect this. **Do not use the stove until an engineer says it is safe to do so.**

8. THE FLAME FAILURE DEVICE

- 8.1 This is a safety feature incorporated in all GAZCO fires, which automatically switches off the gas supply if the pilot light goes out and fails to heat the thermocouple.

9. 'RUNNING IN'

- 9.1 The surface coating on your GAZCO stove will 'burn off' during the first 24 hours of operation on high, producing a harmless and temporary odour. If the odour persists ask your retailer for advice.

10. SERVICING

- 10.1 A qualified gas engineer must service the stove every 12 months. In all correspondence, always quote the appliance type and the Serial Number found on the data badge on the appliance.

11. VENTILATION

- 11.1 Any purpose provided ventilation should be checked periodically to ensure it is free from obstruction.

12. INSTALLATION DETAILS

- 12.1 To assist in any future correspondence, your installer should have completed the Appliance Commissioning Checklist in this manual. This records the essential installation details of this appliance. In all correspondence always quote the Model No. and Serial No.

13. HOT SURFACES

- 13.1 Parts of this appliance become hot during normal use. It is recommended that a suitable fire guard be used for protection of young children and the infirm. Indeed, all parts of the appliance should be treated as a 'working surface' except for the control area.

INSTALLATION INSTRUCTIONS

TECHNICAL SPECIFICATION

Ceramica Manhattan 8578-P8578

| Model | Gas CAT | Gas Type | Working Pressure | NOX Class | Aeration | Injector | Gas Rate m ³ /h | Input kW (Gross) | | Country |
|---|-----------------|-----------------|------------------|-----------|-------------|----------|----------------------------|------------------|-----|---------|
| | | | | | | | | High | Low | |
| 8578 - Ceramica Manhattan | I _{2H} | Natural Gas G20 | 20 mbar | 5 | ø 11mm | 375 | 0.622 | 6.45 | 2.5 | GB, IE |
| P8578 - Ceramica Manhattan | I ₃₊ | LPG Propane G31 | 37 mbar | 5 | ø 15 x 2 mm | 170 | 0.18 | 6.30 | 2.5 | GB, IE |
| | | LPG Butane G30 | 29 mbar | | | | | | | |
| Efficiency Class II Flue Outlet Size 127 mm (5") ø Gas Inlet Connection Size 8 mm ø | | | | | | | | | | |
| Minimum flue specification T260/N2/O/D/1 | | | | | | | | | | |
| Maximum flue temperature 180°C | | | | | | | | | | |

Packing Checklist

Qty Description

- 1 Stove
- 1 Flue Blanking plate
- 1 Flue In fill plate
- 1 Coal set*
- 1 Flame Baffle*
- 1 Front Coal*
- 1 Fixing kit containing
- 1 Instruction Manual
- 2 Wood screws
- 2 Rawlplugs
- 1 Box spanner

*Packed in appliance

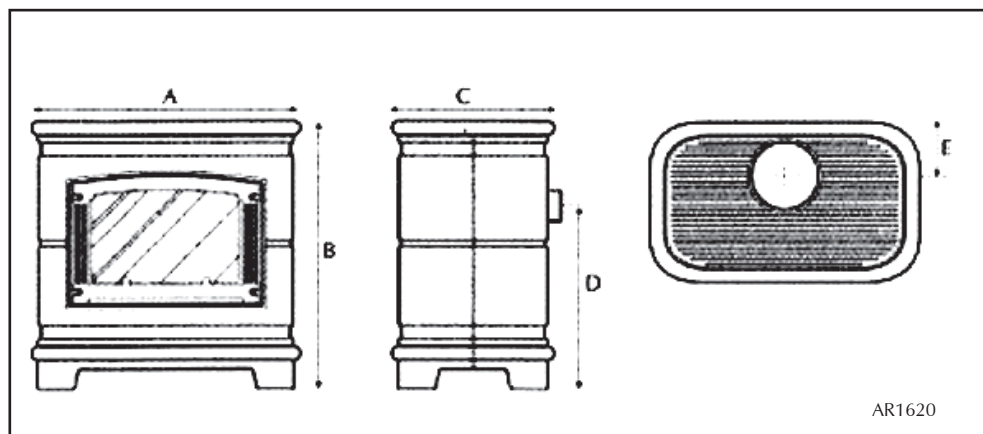

AR1620

| A | | B | | C | | D | | E | |
|-----|-----|-----|-----|-----|-----|--------------------------------|-----|-----|-----|
| ins | mm | ins | mm | ins | mm | ins | mm | ins | mm |
| 28 | 711 | 27½ | 700 | 16¾ | 427 | 17 ⁷ / ₈ | 453 | 5¾ | 145 |

INSTALLATION INSTRUCTIONS

SITE REQUIREMENTS

1. FLUE AND CHIMNEY REQUIREMENTS

- 1.1 The chimney or flue system must comply with the rules in force, and must be a minimum of 127mm in diameter. (5").
- 1.2 The minimum height of the flue or chimney must be 3 metres (10ft). Any horizontal flue run from the rear outlet should not exceed 100mm from the back of the appliance.
- 1.3 The chimney or flue must be free from any obstruction. Any damper plates should be removed or secured in the fully open position and no restrictor plates should be fitted.
- 1.4 The chimney should be swept prior to the installation of the appliance, but where it can be seen that the chimney is clean and unobstructed throughout its entire length, it need not be swept.

NOTE: If it is intended to fit the stove into an existing brick-built chimney, a 5" (127mm) liner must be used. Larger lined flues may work, but in some instances could cause cold start flue problems resulting in nuisance shutdown. Lined flues above 7" (175mm) are not recommended.

Due to recent changes to European chimney standards, new flues and chimneys are now described by their temperature, pressure and resistance to corrosion, condensation and fire. To assist in identifying the correct flue system, the minimum flue specification is shown in the Technical Specification in this manual. Existing chimneys are not covered by this system.

2. VENTILATION

- 2.1 The large stove has a rated output in excess of 7Kw and requires a minimum of 11cm² permanent effective free air. This is in addition to any window that opens, and although it must communicate with the outside air whenever possible, it can communicate with an adjacent room providing such space has a similar opening to the outside. The small and medium stoves have a rated output below 7Kw and do not normally require any additional ventilation.

3. INSTALLATION OF THE GAS SUPPLY

- 3.1 Before installation, ensure the local distribution conditions (identification of the type of gas and pressure) and the adjustment of the appliance are compatible.
- 3.2 Ensure that the gas supply is capable of delivering the required amount of gas, and is in accordance with the rules in force.
- 3.3 Soft copper tubing and soft soldered joints can be used but must not be closer than 50mm to the base of the tray.
- 3.4 A means of isolating the gas supply to the appliance must be provided, independent of any appliance control.
- 3.5 All supply gas pipes must be purged of any debris that may have entered, prior to connection to the appliance.

4. APPLIANCE LOCATION

- 4.1 This stove must stand on a non-combustible hearth that is at least 12mm thick and projects 50mm minimum from the base of the fire in all directions.
- 4.2 Do not install in a room that contains a bath or shower.

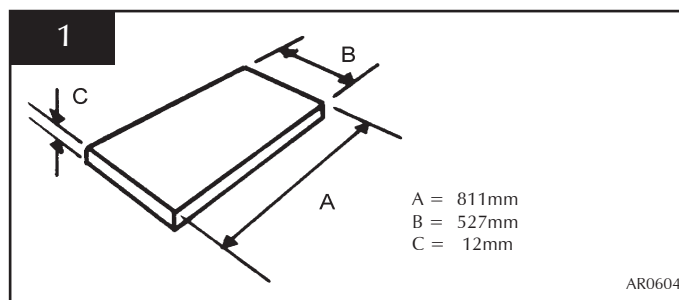

MINIMUM CLEARANCE

- 4.3 The fire is not suitable for installation against a combustible wall. All combustible materials must be removed from behind the fire.
- 4.4 **Ensure you comply with all minimum clearance measurements, whether or not to combustible materials.**

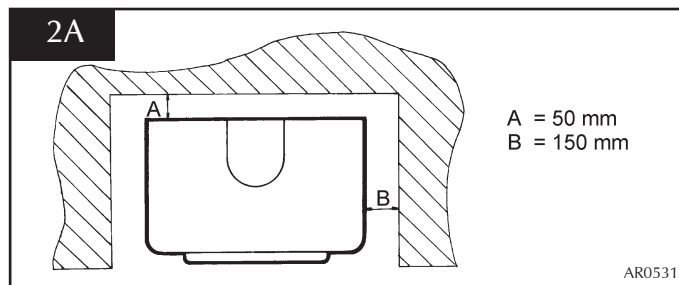
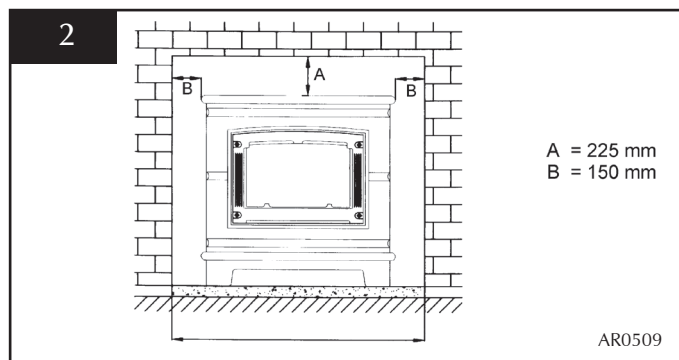

The above dimensions provide adequate clearance at the side and rear of the fire so that the controls can be reached.

INSTALLATION INSTRUCTIONS

INSTALLATION

IMPORTANT: ENSURE THAT THE APPLIANCE IS CORRECTLY ADJUSTED FOR THE GAS TYPE AND CATEGORY APPLICABLE IN THE COUNTRY OF USE. REFER TO DATABADGE AND TECHNICAL SPECIFICATIONS OF THIS BOOKLET.

FOR DETAILS OF CHANGING BETWEEN GAS TYPES REFER TO *SERVICING INSTRUCTIONS, REPLACING PARTS.*

1. CONTROL UPGRADE

- 1.1 This stove is fitted with a control valve that can be easily upgraded to battery powered remote control. There are two versions of this control which can be obtained through your local Gazco stockist.
- 1.2 This upgrade can be fitted before or after installation but if side clearances are limited then it will be easier to upgrade the stove before installation. Full instructions are included with the kit.
- 1.3 **STANDARD REMOTE CONTROL.** This remote controls the gas appliance after the pilot has been lit. It can turn the main burner on and regulate it from low through to high and back again. It can turn the main burner off leaving the pilot burning GAZCO PART NUMBER 8455.
- 1.4 **THERMOSTATIC AND TIMER REMOTE CONTROL.** This remote controls the gas appliance after the pilot has been lit. In 'MANUAL MODE' it can be used to turn the main burner on and manually regulate it from low through to high and back again. It can also be used to turn the main burner leaving the pilot burning. In 'AUTO MODE' it will automatically regulate the room temperature to a pre-set temperature. In 'TIMER MODE' it will turn the fire on and off according to a pre-set programme and automatically regulate the room temperature during the two ON periods. GAZCO PART NUMBER 8456.

2. SAFETY PRECAUTIONS

- 2.1 This appliance must be installed in accordance with the rules in force and used only in a sufficiently ventilated space. Please read these instructions before installation and use of this appliance.
- 2.2 All the instructions must be left intact with the user.
- 2.3 In your own interest, and those of safety, this appliance must be installed by a competent person in accordance with local and national codes of practice. Failure to install the appliance correctly could lead to prosecution.
- 2.4 This appliance is intended for use on a governed gas installation and set to the required pressure.
- 2.5 Keep all plastic bags away from young children.
- 2.6 Do not place any object on or near to the stove. Allow adequate clearance above the stove. See Diagram 2, Appliance Location..

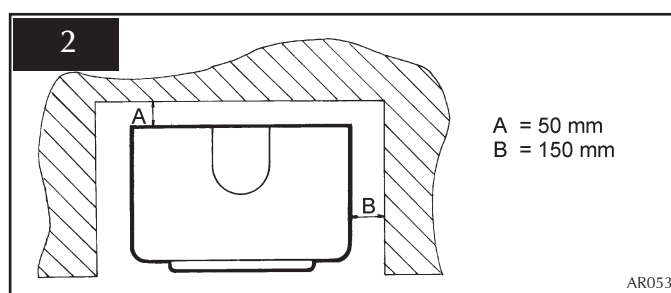
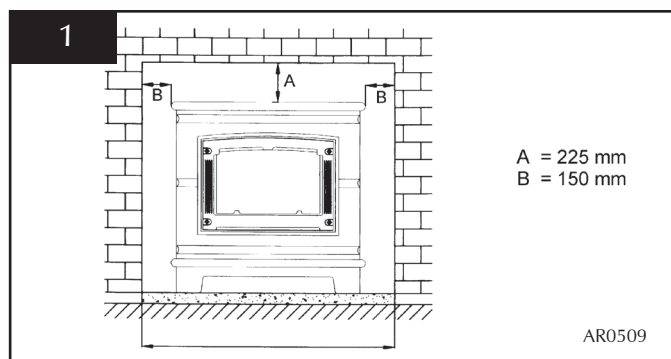

- 2.7 The stove is fitted with the **Gazco Flue Sure System**, which acts to cut off the gas supply to the appliance in the event of incorrect operation of the flue. If the system acts to shut off the gas supply, this indicates there is insufficient flue pull. If this occurs a minimum of 10 minutes should be allowed before trying to relight. Continued operation of this safety device means there may be a serious problem with the flue system and a qualified gas engineer must inspect. **DO NOT USE THE STOVE UNTIL AN ENGINEER SAYS IT IS SAFE TO DO SO.**
- 2.8 Do not tamper with the Flue Sure System. Use only genuine Gazco replacement parts when servicing the system - refer to *Servicing Instructions, Replacing Parts.*

3. INSTALLATION OF THE STOVE

- 3.1 Open the carton containing the engine assembly, and carefully remove the engine. It will now be necessary to decide upon top or rear flue exit, the stove is factory built for rear flue exit, but it may be changed to top exit by simply using the following method.
- 3.2 Remove the flue spigot from the rear of the stove and replace with the blanking plate from the top of the stove. Refit flue spigot to top of stove.
- 3.3 When installing with a top flue please note the flue pipe fits through a hole in the top grill, the dimensions are for floor fixing a top flue installation with clearance for side panels.
- 3.4 Position the engine assembly in its intended location and mark the position of the two floor fixing holes at the base of each side of the subframe, minimum fixing dimensions to a rear wall are shown in Diagram 3.

INSTALLATION INSTRUCTIONS

INSTALLATION

- 3.5 Remove the assembly and drill the two holes using a No. 12 masonry bit. Push the rawl plugs into the holes, and place the engine assembly in position, secure to the floor using the screws provided. See Diagram 3.

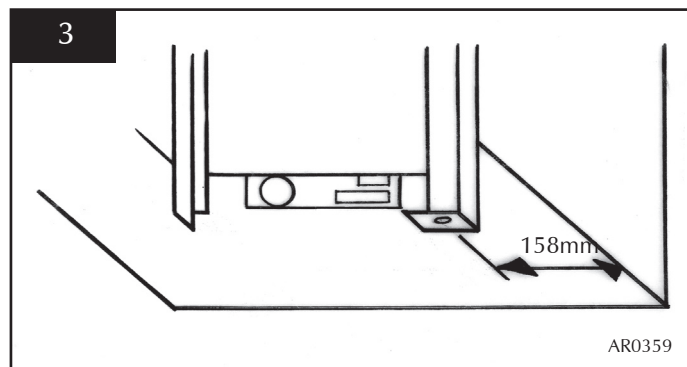

- 3.6 Having run the gas supply to the stove, **PURGE THE SUPPLY PIPE**, this is essential to expel any debris that may block the gas controls. connect the gas supply to the 8mm-compression elbow at the RH rear corner of the stove, ensuring that the pipe position does not interfere with the location of the outer steel casing. See Diagram 4.

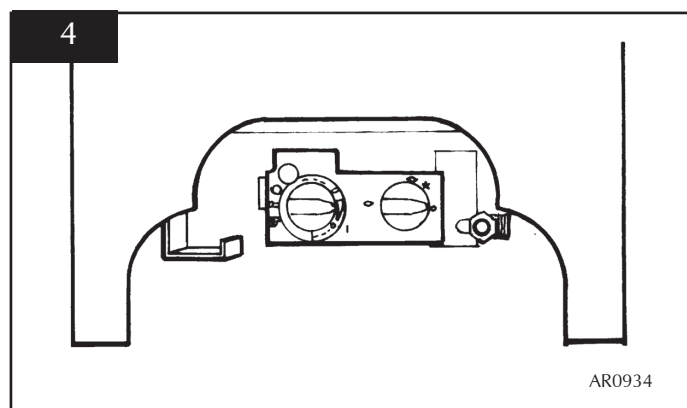

- 3.7 Open the second carton, and carefully remove the ceramic outer casing components. Gently position the LH side so that the bolt heads on the engine subframe locate in the keyhole slots on the back of the panel, and gently slide into place so that the ceramic comes to rest on the floor. Repeat the procedure for the RH side, see Diagram 5.

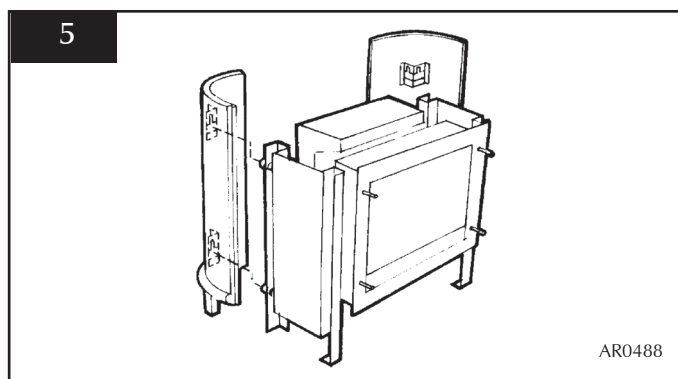

- 3.8 Remove the cast iron door using the tool provided, and carefully place to one side. Gently position the front ceramic panel so that the side panels locate inside the returns on the front panel, engage the bolt heads in the brackets on the back of the panel and gently slide into place so that the ceramic comes to rest on the floor, ensure that the opening in the panel sits centrally around the fire box opening, see Diagram 6.

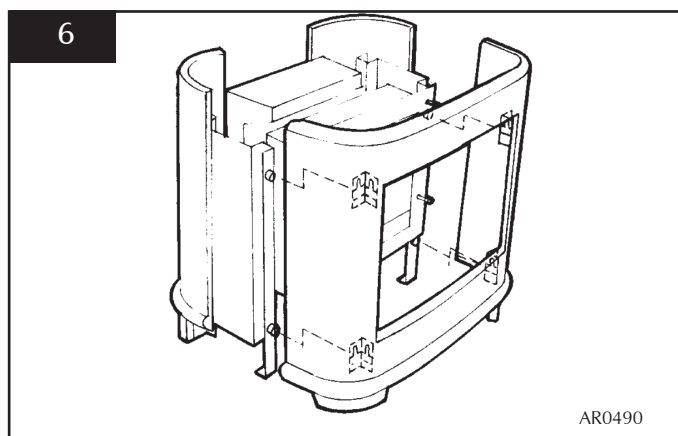

INSTALLATION INSTRUCTIONS

INSTALLATION

Medium Ceramica

- 3.9 Place the flame baffle onto the shelf at the rear of the tray and push up against the rear ledge, see Diagram 7.

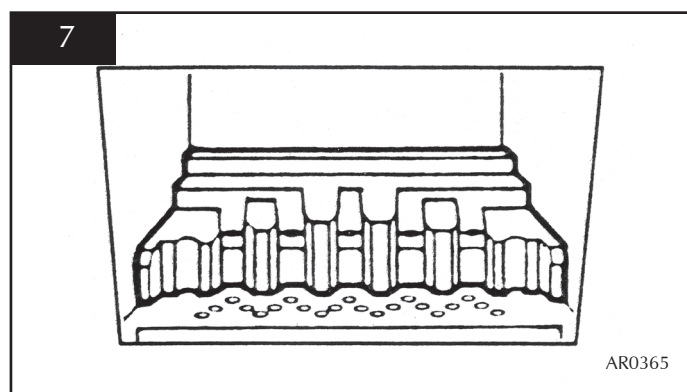

- 3.10 Locate the front coal moulding in front of the flame baffle ensuring that the end legs sit flat against the burner skin, see Diagram 8.

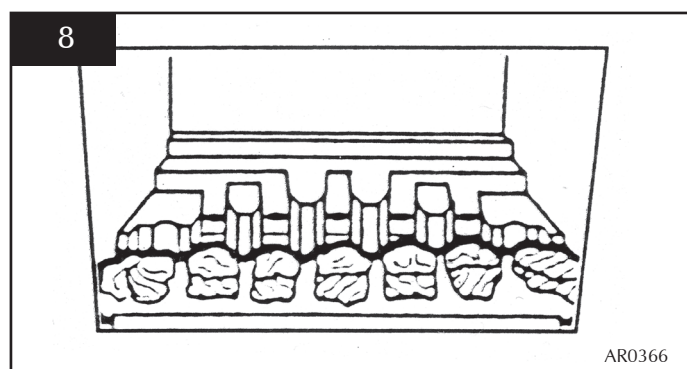

- 3.11 Place three large coals on the front coal so that they lean against the flame baffle, and the four large coals on the flame baffle so that they sit on the fingers, see Diagram 9.

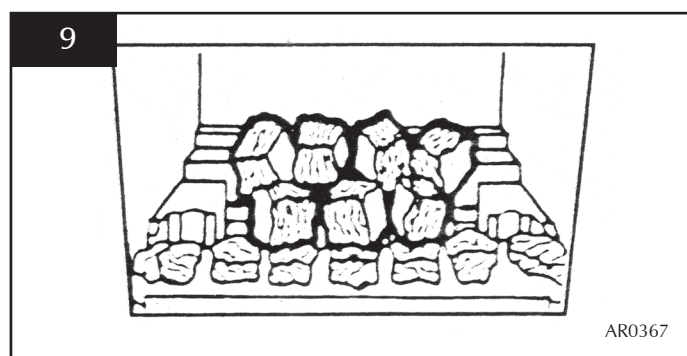

- 3.12 Place two small coals at each end of the front coal so that they lean against the flame baffle, and a further two large coals on the flame baffle, one at each end, see Diagram 10

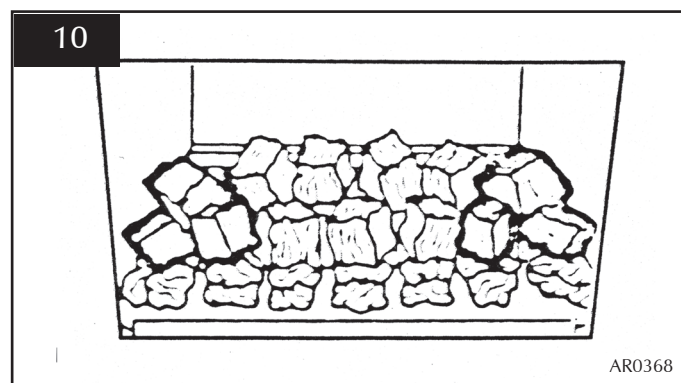

- 3.12 Place five small coals along the rear of the flame baffle, resting against the rear ledge, see Diagram 11.

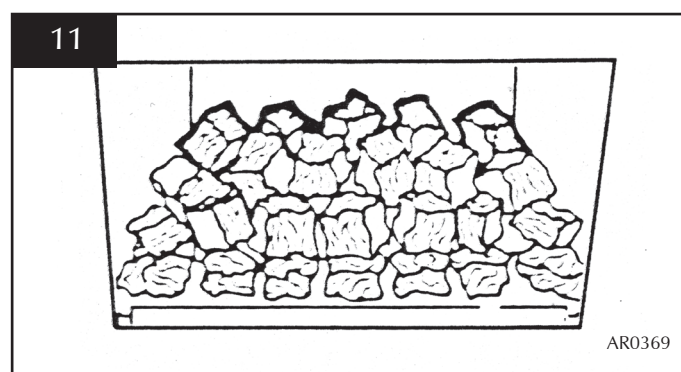

- 3.14 Ensure that the fibreglass seal on the back of the door is intact, locate the door on the four studs and slide back to the firebox. Secure in place using the four dome nuts and the tool supplied, do not over tighten the nuts, see Diagram 12. Keep the tool with these instructions for future use.

NEVER OPERATE THE STOVE WHEN THE DOOR IS REMOVED OR WHEN THE GLASS IS BROKEN.

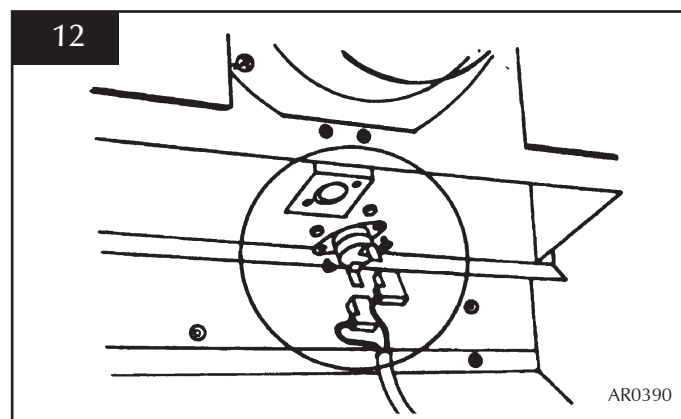

INSTALLATION INSTRUCTIONS

INSTALLATION

- 3.15 Place the top ceramic panel into position so that the two spring clips slide against the inside of the side panels, gently position so that it sits centrally in the outer panels. Place the cast iron grille into the recess in the centre of the top panel, and locate the blanking plate into the grille, (if required), see Diagram 13.

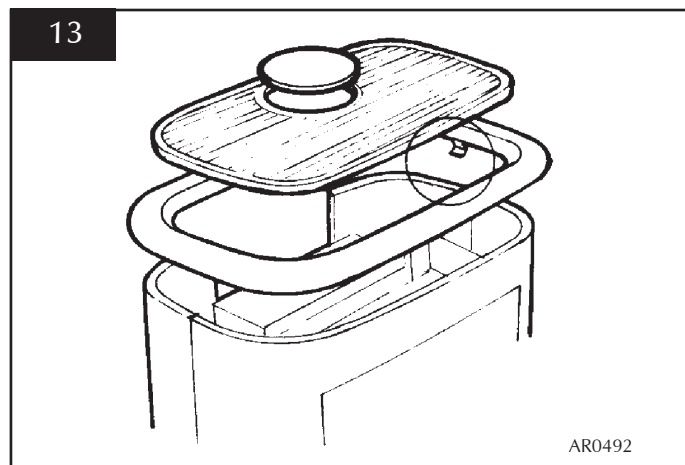

- 3.16 Check the pull of the flue system by applying a lighted smoke pellet to the flue system opening. If there is a definite flow into the flue, proceed with the installation, if not warm the flue for a few minutes and repeat the test.
IF THERE IS STILL NO DEFINITE FLOW, THE FLUE MAY REQUIRE ATTENTION - SEEK EXPERT ADVICE
- 3.17 The flue system may now be connected to the stove, ensure that all joints are sealed with a suitable fire resistant sealant. It is also recommended that a physical retention method be used at the flue spigot joint, self-tapping screws being favoured.
- 3.17 Connect a suitable pressure gauge to the test point located on the inlet fitting and turn the gas supply on. Light the appliance and check all gas joints for gas soundness. Turn the appliance to maximum and check that the supply pressure is as stated on the databadge. Turn the gas off and replace the test point screw, turn the gas on and check the test point for gas soundness.

4. LIGHTING

- 4.1 Full instructions are given in Section 2.

INSTALLATION INSTRUCTIONS

COMMISSIONING

1. COMMISSIONING

- 1.1 Close all openable doors and windows in the room. Ignite the stove and operate on maximum for 10 minutes. Position a lighted smoke match just inside the draught diverter opening and check that all smoke is drawn into the opening. In restricted locations a mirror can be used. See Diagram 1. If there is any doubt, run the stove for a further 10 minutes, and repeat the test.

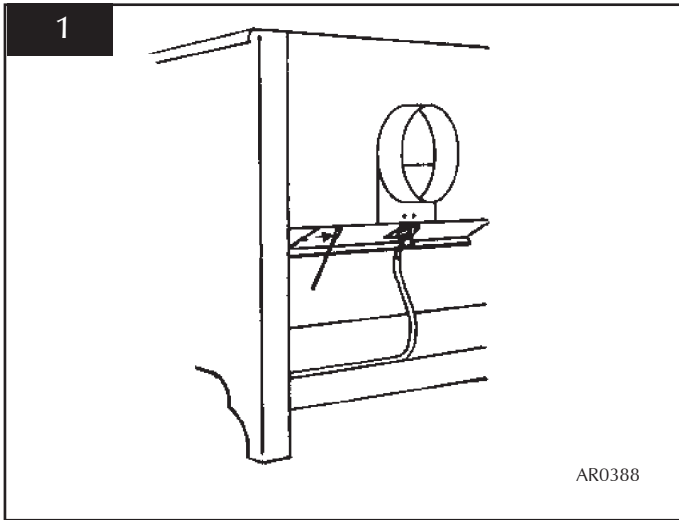

- 1.2 If there are any extractor fans in adjacent rooms, the test must be repeated with the fans running on maximum and interconnecting doors open.

IF SPILLAGE PERSISTS, DISCONNECT THE APPLIANCE AND SEEK EXPERT ADVICE.

For future reference record the installation details on the Appliance Commissioning Checklist of these instructions.

SERVICING INSTRUCTIONS

SERVICING / FAULT FINDING CHARTS

1. SERVICING REQUIREMENTS

This appliance must be serviced at least once a year by a competent person.

All tests must be serviced by best practice as described by the current CORGI recommendations.

Refer to **ADVICE ON HANDLING AND DISPOSAL OF FIRE CERAMICS** In *User Instructions* section 5

- 1.1 Before any tests are undertaken on the appliance, conduct a gas soundness test for the property to ensure there are no gas leaks prior to starting work.
- 1.2 Before any tests are undertaken on the appliance it is also recommended to fully check the operation of the appliance.
- 1.3 Special checks
 - 1.3.1 Clean any lint or fluff from the pilot - pay particular attention to the aeration hole in the side of the pilot
 - 1.3.2 Clean away any fluff or lint from under the burner
 - 1.3.3 Check the spark gap on the pilot is correct
- 1.4 Correct any faults found during the initial tests and then re-commission the appliance conducting the usual safety checks.
- 1.5 Advise the customer of any remedial action taken.

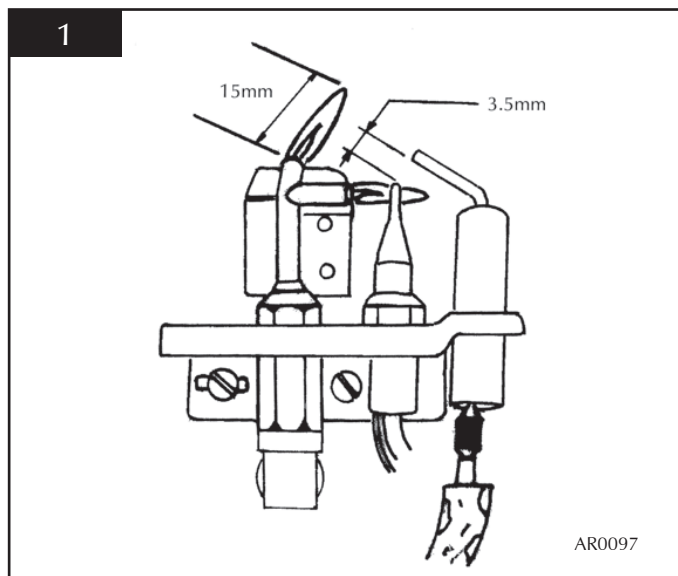

IGNITION FUNCTIONAL CHECK 1

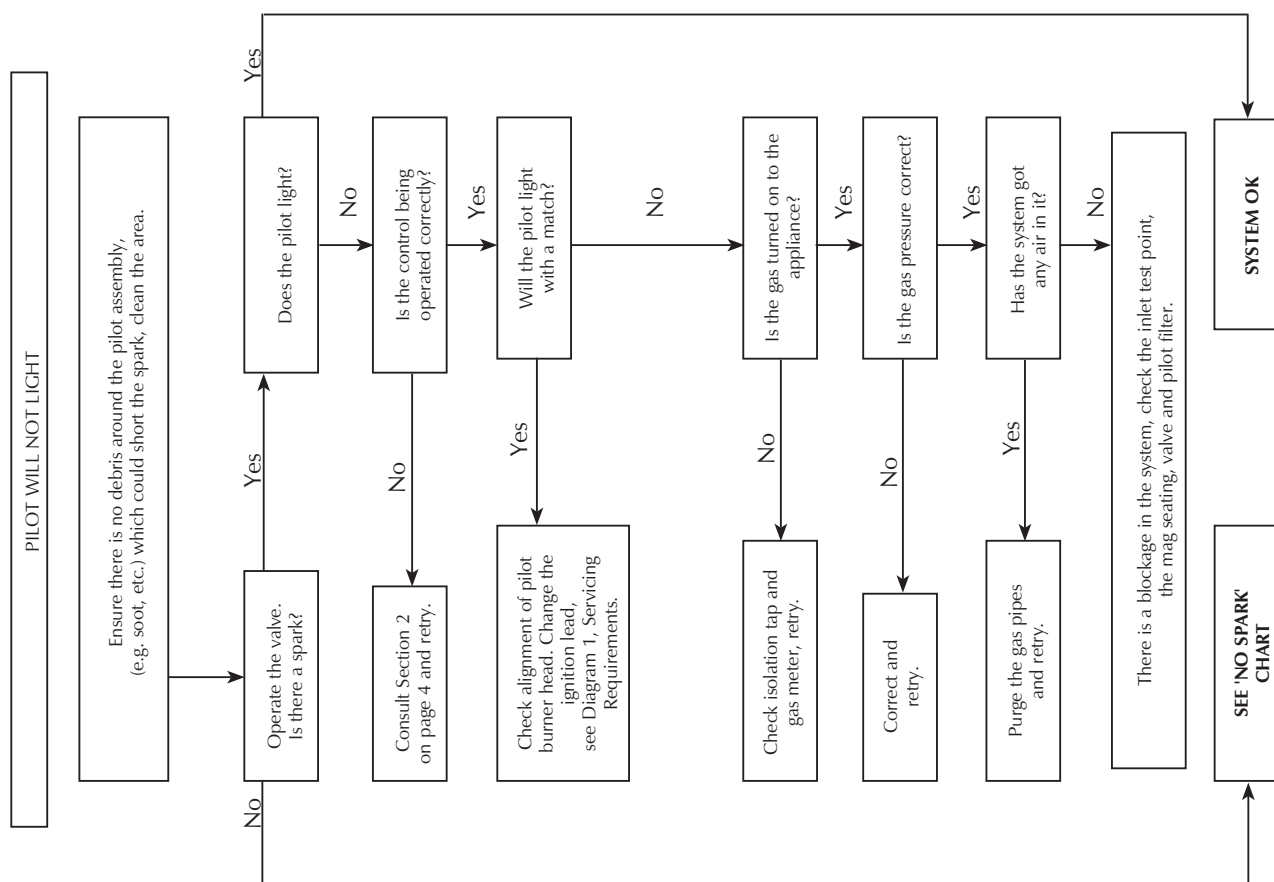

SERVICING INSTRUCTIONS

FAULT FINDING CHARTS

FLAME FAILURE FUNCTIONAL CHECK

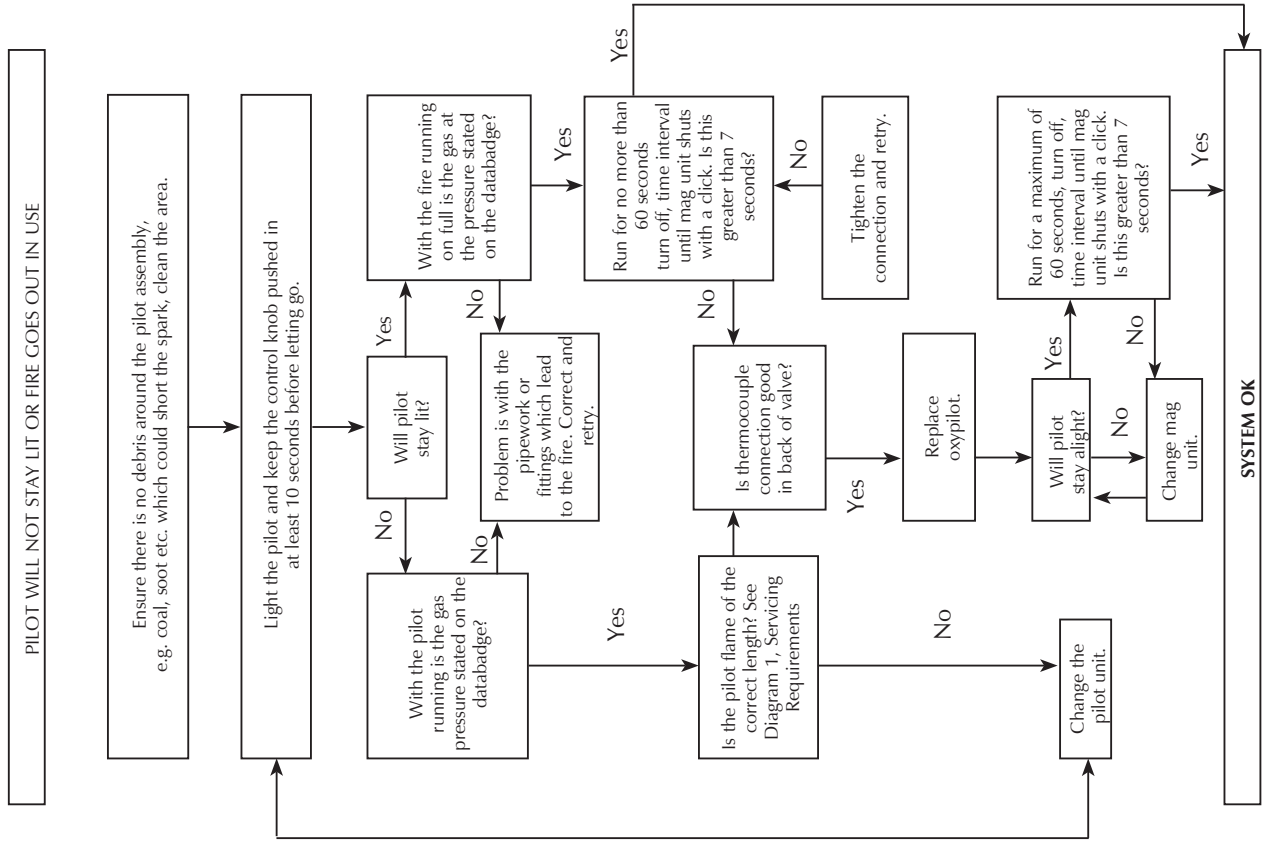

IGNITION FUNCTIONAL CHECK 2

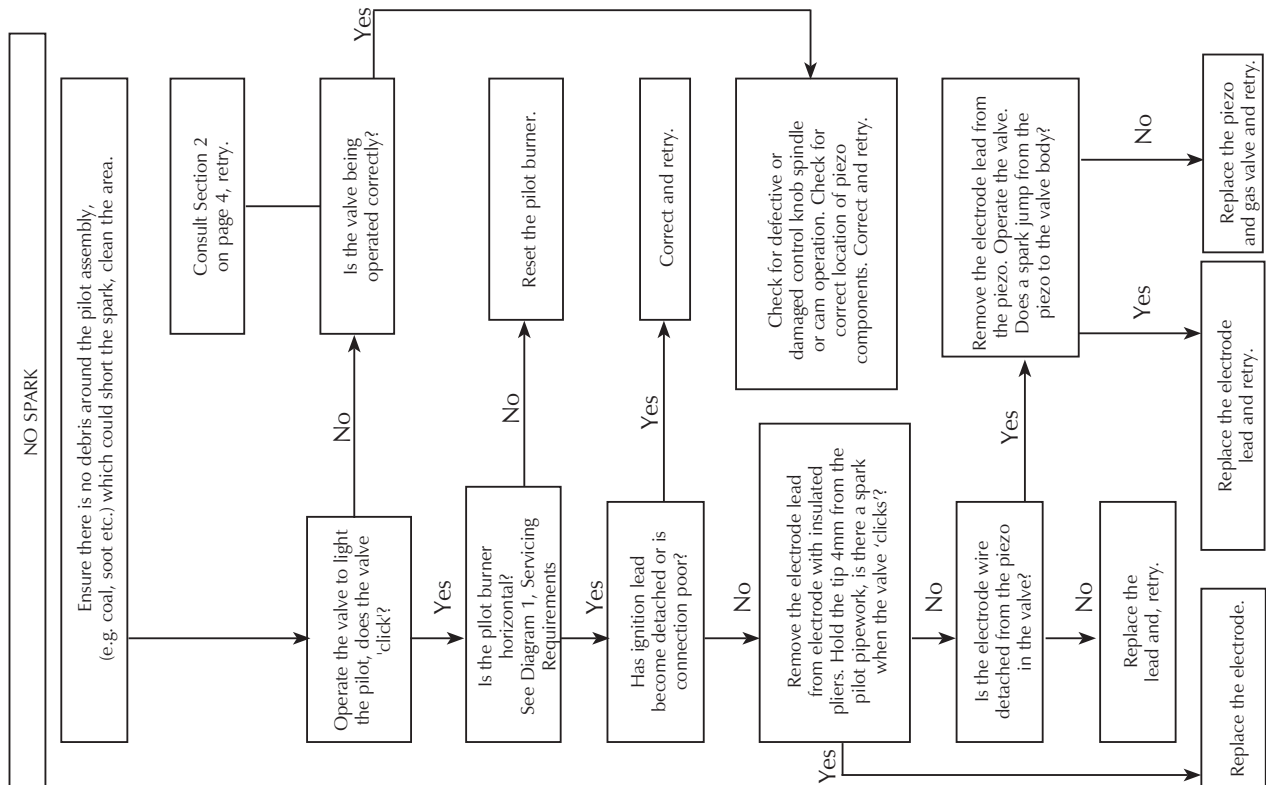

SERVICING INSTRUCTIONS

REPLACING PARTS

1. GENERAL

- 1.1 All principal components can be replaced without removing the stove from its installation, although it will be necessary to remove the door and ceramic outer casing in order to access most components. In order to remove the casing, use the following procedure:
- 1.2 Remove the door retaining nuts using the tool provided and place the door to one side.
- 1.3 Carefully remove the top blanking plate and grille and place to one side, gently remove the top ceramic panel, see Diagram 1. If the unit has been connected to a top exit flue, it will be necessary to lift and support the grille and top ceramic panel whilst removing the outer ceramic components.

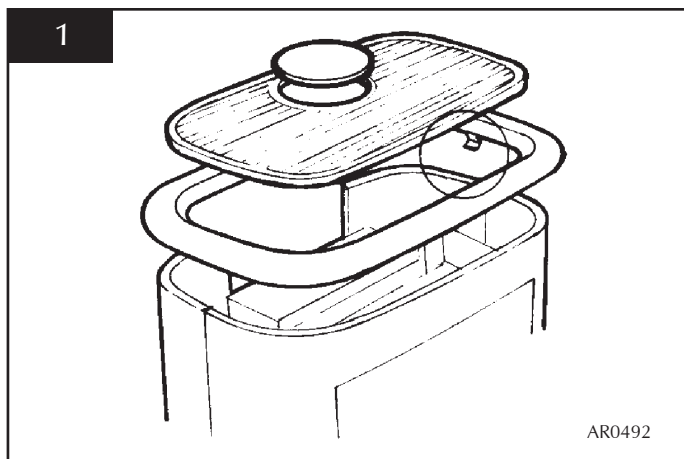

- 1.4 Gently lift the front ceramic panel, and pull away from the sub-frame to clear the retaining bolts, see Diagram 2.

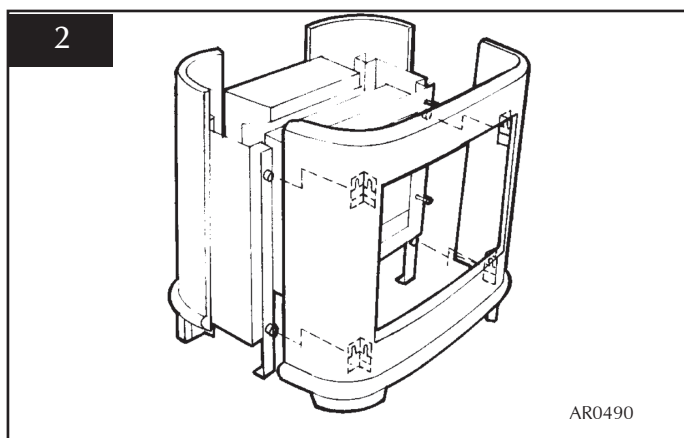

- 1.5 Carefully remove the two side panels by lifting, and gently pulling clear of the retaining bolts, see Diagram 3. It may not be necessary to remove both of the side panels. This should allow full access to all major components.

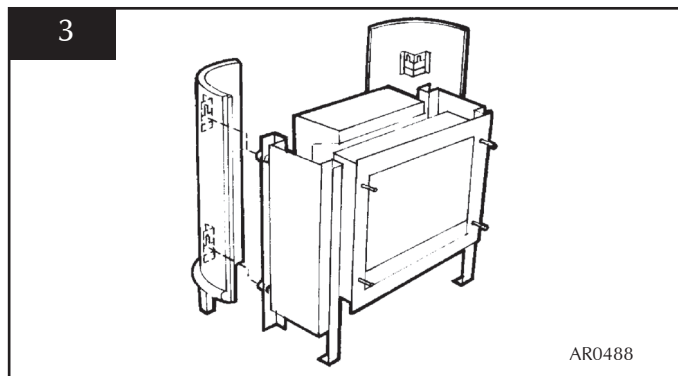

2. BURNER UNIT REMOVAL

- 2.1 Turn the gas supply off at the isolation device. Ensure the unit is cool.
Use cover material to front of appliance to protect paintwork etc.
Remove the door and place to one side. (4 nuts).
Carefully remove the ceramic fuel components to a safe place.
Remove front cover-plate (2 screws).
Remove cover plate fixing bracket (2 wing nuts).
(Small Stoves only)
Unscrew pilot union nut on gas valve. See Diagram 4.

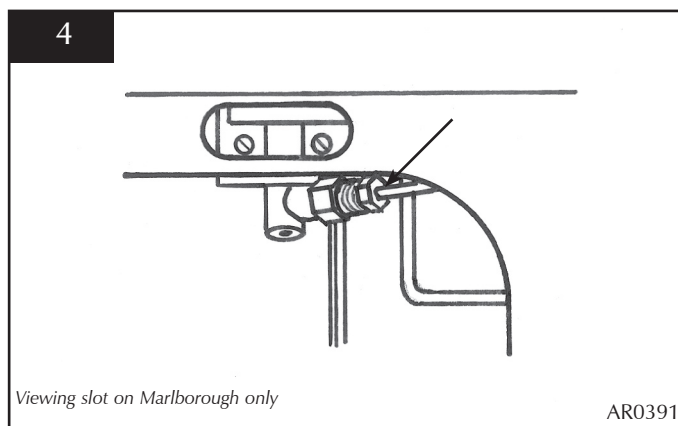

- 2.2 Disconnect thermocouple from gas valve. See Diagram 2.
Remove ignition lead from electrode. (Cut cable tie to ignition lead if required).

SERVICING INSTRUCTIONS

REPLACING PARTS

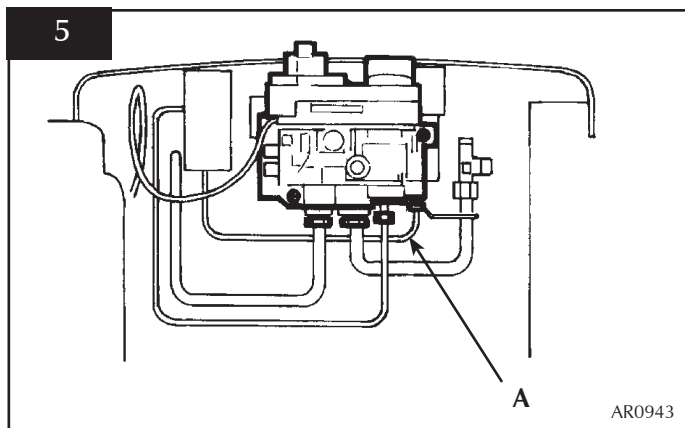

- 2.3 Loosen main injector nut on airbox and disconnect from injector, see Diagram 6, A.

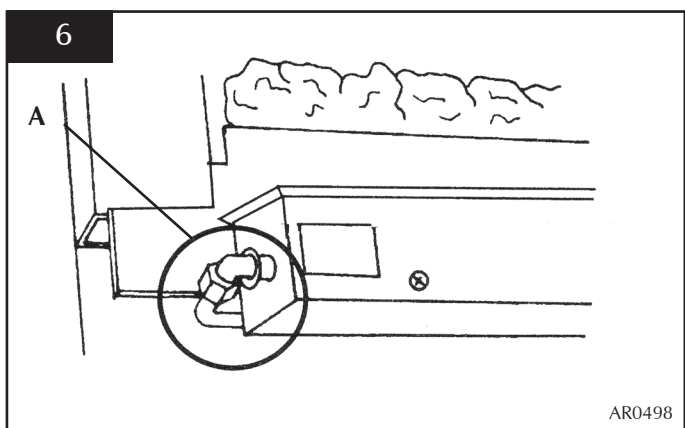

- 2.4 Remove the 2 screws attaching burner to back of unit, see Diagrams 7. Carefully withdraw burner upwards and tilt to remove the burner through door opening. Remove the 2 screws holding the heat shield in place.

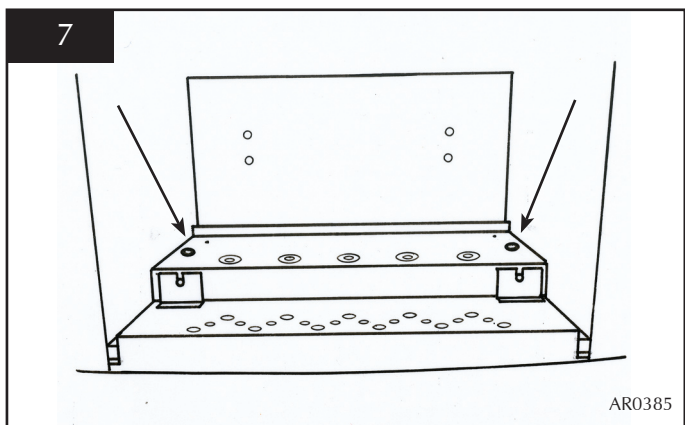

Replace in reverse order checking all joints for leaks.

3. PILOT UNIT

- 3.1 Remove the burner module as described in Servicing Section 2 above. Carefully cut the cable ties holding the thermocouple to the pilot pipe. Remove the HT lead from the electrode, undo the two retaining screws and remove the pilot. See Diagram 8.

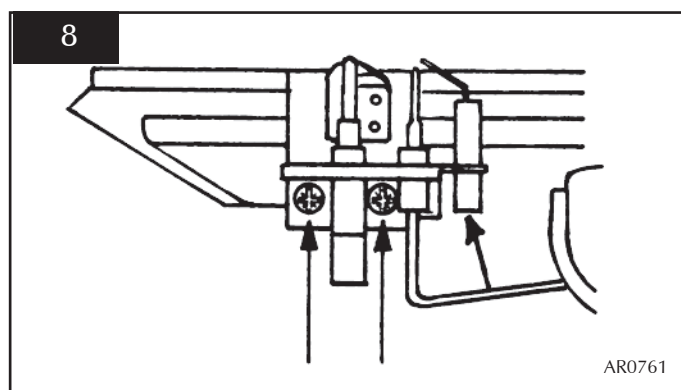

- 3.2 When replacing the pilot ensure the thermocouple follows its original route, i.e. along the pilot pipe. Attach the thermocouple to the pipe with new cable ties.
- 3.3 Set the spark gap. See Diagram 9.

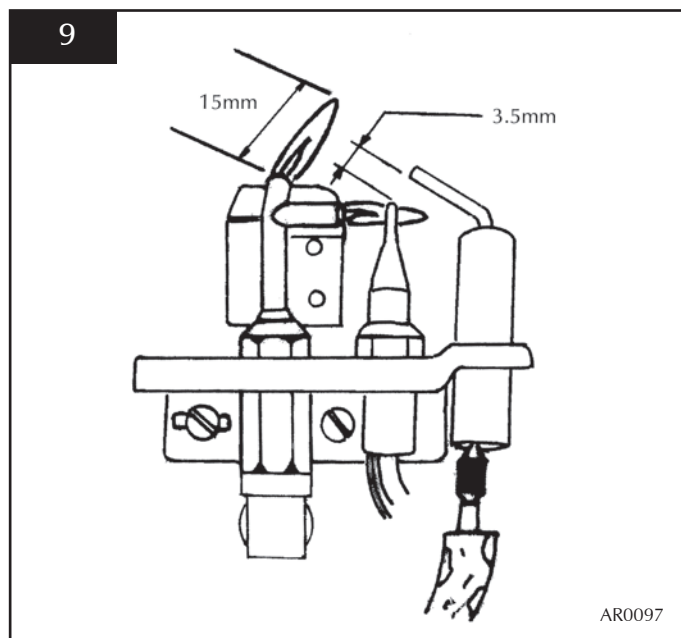

SERVICING INSTRUCTIONS

REPLACING PARTS

4. IGNITION LEAD AND PIEZO

- 4.1 Gain access to the back of the pilot assembly, (see section 2) and disconnect the ignition lead from the electrode.
- 4.2 Remove the front cover from the control valve, (see Diagrams 10 and 11). Disconnect the other end of the ignition lead from the valve body. Note the existing route of the ignition lead.

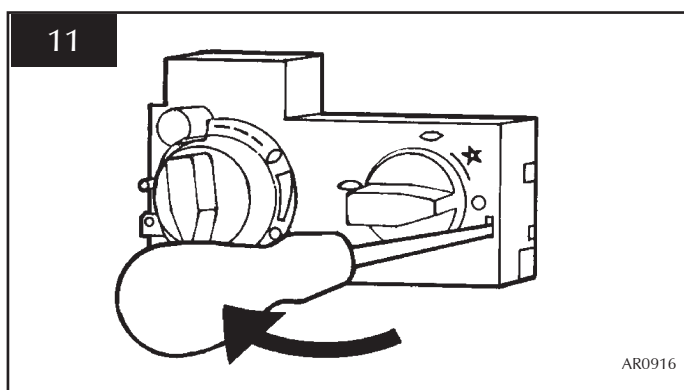
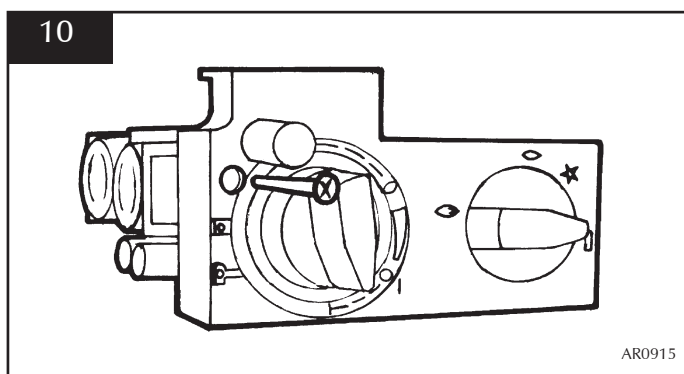

- 4.3 Replace with a new ignition lead following the same route as the old one. Replace the valve cover and the pilot assembly.
- 4.4 Check operation of the new ignition lead.

5. PIEZO

- 5.1 The piezo assembly used on this appliance is not serviceable and is unlikely to fail.
- 5.2 If a new piezo is required it will be necessary to change the gas valve. Refer to Section 6.

6. GAS VALVE

- 6.1 Turn the gas supply off at the isolation device.
- 6.2 Disconnect the 2x8mm and 1x4mm gas pipe fittings at the back of the gas valve and also disconnect the thermocouple, see Diagram 12.

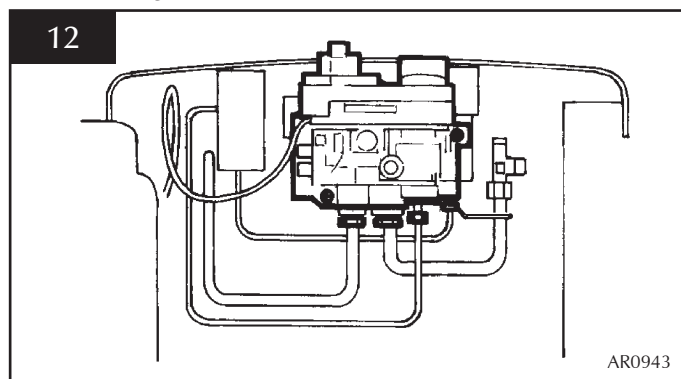

- 6.3 Undo the single screw that secures the left-hand side of the control cover, see Diagram 13.

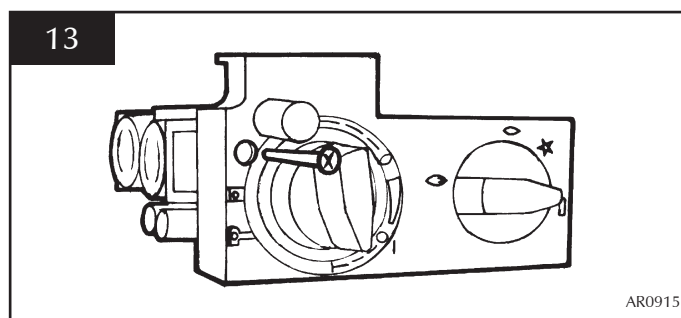

- 6.4 To release the right-hand side of the control cover, insert the narrow blade screwdriver into the slot shown in Diagram 11. Lever it gently and pull from the right-hand side at the same time. The cover will now come off. There is a small cylindrical metal spacer inside the cover. This must be kept and replaced on the fixing screw during re-assembly.

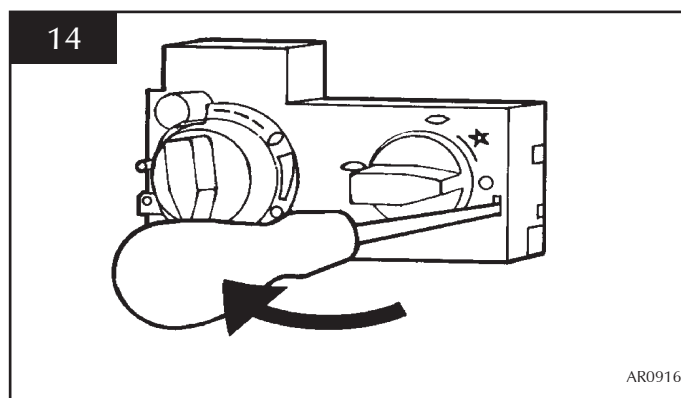

SERVICING INSTRUCTIONS

REPLACING PARTS

- 6.5 Disconnect the ignition lead from the gas valve.
- 6.6 Undo the two bolts securing the gas valve to the appliance and remove the valve.
- 6.7 Replace in reverse order.
- 6.8 Check all joints for gas leaks. Check operation of the thermocouple and ignition lead.

7. MAGNETIC SAFETY VALVE

- 7.1 Turn the gas supply off at the isolation device. Undo the thermocouple connection from the back of the gas valve. Pull the sensor leads clear and remove the interrupter block.
- 7.2 Undo the magnetic valve-retaining nut from the back of the control valve. Gently tap out the magnetic valve and replace with a new unit. Replace the retaining nut and tighten. See Diagram 15.

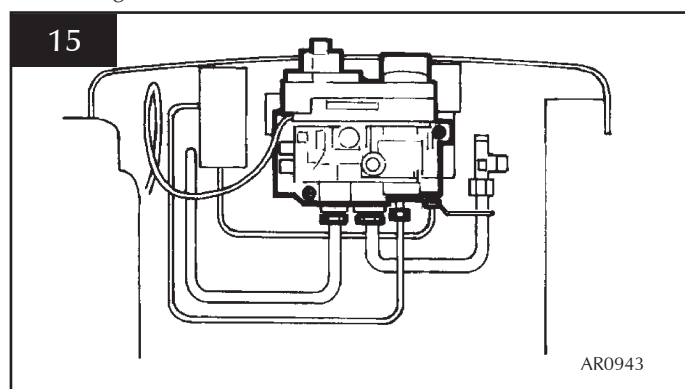

- 7.3 Reassemble the interrupter block and leads. Secure the thermocouple connection in the rear of the gas control. (Do not overtighten). Turn the gas supply on and check the entire pipework and valve joints for any leaks.

8. MAIN INJECTOR

- 8.1 Turn the gas supply off at the isolation device. Locate the main injector on the LH side of the airbox, undo the compression nut and pull the pipe clear of the injector body, see Diagram 16, A.

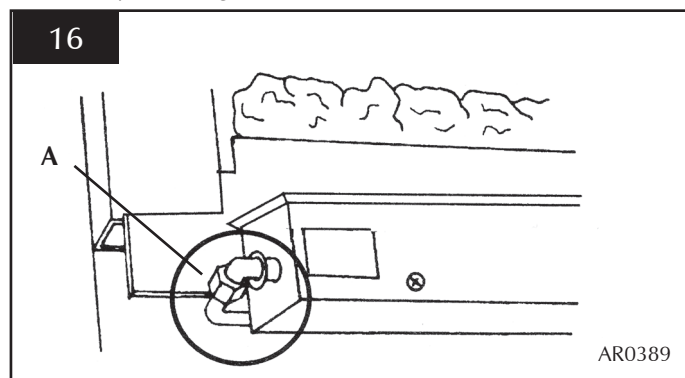

- 8.2 Rotate the injector until it is fully removed, and install the correct replacement injector. Reassemble and turn the gas supply on, check for leaks.

9. GAZCO FLUE SURE SYSTEM

If the stove has been installed in a restrictive location, it may be necessary to remove the stove from its location.

- 9.1 Locate the sensor in the draught diverter opening, and gently pull the two wires off the terminals. Undo the two taptite screws and remove the sensor and the two plastic spacers. See Diagram 17.

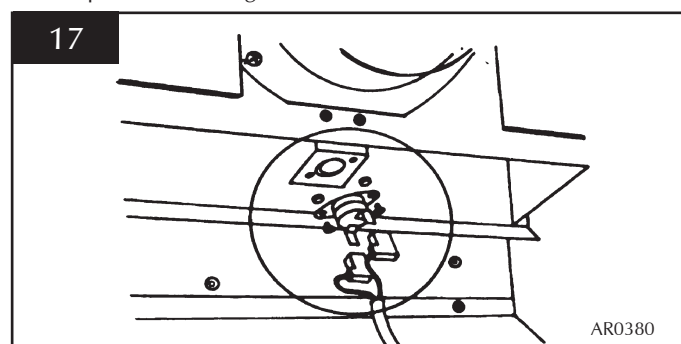

- 9.2 Refit a new sensor ensuring the spacers are located between the sensor and the bracket. Replace the two leads.
- 9.3 If it has been necessary to remove the stove, ensure that all disturbed gas joints are checked for gas soundness when reinstalled, and repeat the flue clearance test as detailed in the Commissioning Section.

10. PRIMARY AERATION PLATE

- 10.1 Turn the gas supply off at the isolation device.
- 10.2 Locate the aeration plate on the underside of the airbox and remove the Nyloc nut, see Diagram 18.

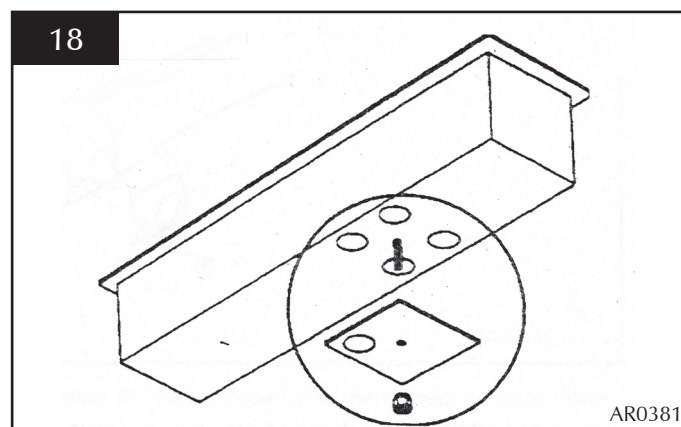

- 10.3 Remove the plate and replace with the correct size, ensure that the hole(s) in the plate align correctly with the holes in the underside of the airbox and replace the Nyloc nut.

SERVICING INSTRUCTIONS

REPLACING PARTS

11. CHANGING BETWEEN GAS TYPES

11.1 In order to change between gas types, it will be necessary to change the following items.

- Pilot Unit
- Control Valve
- Main Injector
- Aeration Plate (if required)
- Databadge

The relevant parts can be ordered as a conventional kit from Gazco. Always quote the appliance type and serial number when ordering spare parts.

**** NOTE: THE CONTROL VALVE IS FACTORY PRESET FOR CORRECT GAS TYPE AND MODEL. A NEW UNIT WILL NEED TO BE ORDERED WHEN CHANGING BETWEEN GAS TYPES.**

12. CONTROL UPGRADE

See *Installation*, Section 1.

13. SHORT SPARES LIST

| COMPONENTS | NG | LPG |
|--------------------------|----------|--------|
| Pilot Unit | P10036 | P10037 |
| Injector | IN0045 | IN0006 |
| Aeration Plate | ME1096 | ME0834 |
| Gas Valve | GC0088K* | |
| Flue Sensor | EL0001 | |
| Sensor Lead x 2 | EL0064 | |
| Interrupter | GC0026 | |
| Mag Unit | GC0092 | |
| Ignition Lead | GC0090 | |
| Rear Panel | - | |
| Flame Baffle | CE0120 | |
| Front Coal | CE0124 | |
| Coal Set | CE0136 | |
| Burner Skin | CE0116 | |
| Upgrade Kit Std | 8455 | |
| Upgrade Kit Thermostatic | 8456 | |

SERVICE RECORDS

1ST SERVICE

Date of Service:.....
Next Service Due:.....
Signed:.....
Dealer's Stamp/CORGI Registration Number

2ND SERVICE

Date of Service:.....
Next Service Due:.....
Signed:.....
Dealer's Stamp/CORGI Registration Number

3RD SERVICE

Date of Service:.....
Next Service Due:.....
Signed:.....
Dealer's Stamp/CORGI Registration Number

4TH SERVICE

Date of Service:.....
Next Service Due:.....
Signed:.....
Dealer's Stamp/CORGI Registration Number

5TH SERVICE

Date of Service:.....
Next Service Due:.....
Signed:.....
Dealer's Stamp/CORGI Registration Number

6TH SERVICE

Date of Service:.....
Next Service Due:.....
Signed:.....
Dealer's Stamp/CORGI Registration Number

7TH SERVICE

Date of Service:.....
Next Service Due:.....
Signed:.....
Dealer's Stamp/CORGI Registration Number

8TH SERVICE

Date of Service:.....
Next Due:.....
Signed:.....
Dealer's Stamp/CORGI Registration Number

9TH SERVICE

Date of Service:.....
Next Due:.....
Signed:.....
Dealer's Stamp/CORGI Registration Number

10TH SERVICE

Date of Service:.....
Next Service Due:.....
Signed:.....
Dealer's Stamp/CORGI Registration Number

Gazco Limited, Osprey Road, Sowton Industrial Estate, Exeter, Devon, England EX2 7JG
Tel: Technical Customer Services (01392) 261950 Fax: (01392) 261951
E-mail: technicalservices@gazco.com

A member of the Stovax Group